



Designation: E 1319 – 98

## Standard Guide for High-Temperature Static Strain Measurement<sup>1</sup>

This standard is issued under the fixed designation E 1319; the number immediately following the designation indicates the year of original adoption or, in the case of revision, the year of last revision. A number in parentheses indicates the year of last reapproval. A superscript epsilon ( $\epsilon$ ) indicates an editorial change since the last revision or reapproval.

### 1. Scope

1.1 This guide covers the selection and application of strain gages for the measurement of static strain up to and including the temperature range from 425 to 650°C (800 to 1200°F). This guide reflects some current state-of-the-art techniques in high temperature strain measurement, and will be expanded and updated as new technology develops.

1.2 This practice assumes that the user is familiar with the use of bonded strain gages and associated signal conditioning and instrumentation as discussed in Refs. (1) and (2).<sup>2</sup> The strain measuring systems described are those that have proven effective in the temperature range of interest and were available at the time of issue of this practice. It is not the intent of this practice to limit the user to one of the gage types described nor is it the intent to specify the type of system to be used for a specific application. However, in using any strain measuring system including those described, the proposer must be able to demonstrate the capability of the proposed system to meet the selection criteria provided in Section 5 and the needs of the specific application.

1.3 The devices and techniques described in this practice may be applicable at temperatures above and below the range noted, and for making dynamic strain measurements at high temperatures with proper precautions. The gage manufacturer should be consulted for recommendations and details of such applications.

1.4 The references are a part of this practice to the extent specified in the text.

1.5 The values stated in metric (SI) units are to be regarded as the standard. The values given in parentheses are for information purposes only.

1.6 *This standard does not purport to address all of the safety concerns, if any, associated with its use. It is the responsibility of the user of this standard to establish appropriate safety and health practices and determine the applicability of regulatory limitations prior to use.*

<sup>1</sup> This practice is under the jurisdiction of ASTM Committee E-28 on Mechanical Testing and is the direct responsibility of Subcommittee E28.14 on Strain Gages.

Current edition approved May 10, 1998. Published March 1999. Originally published as E 1319 - 89. Last previous edition E 1319 - 89 (1996) <sup>$\epsilon$ 1</sup>.

<sup>2</sup> The boldface numbers in parentheses refer to the list of references at the end of this practice.

### 2. Referenced Documents

2.1 *ASTM Standards:*

E 6 Terminology Relating to Methods of Mechanical Testing<sup>3</sup>

### 3. Terminology

3.1 *Definitions:*

3.1.1 Refer to Terminology E 6 for definitions of terms relating to stress and strain.

3.2 *Definitions of Terms Specific to This Standard:*

3.2.1 Terms pertinent to this guide are described as follows:

3.2.2 *capacitive strain gage*—a strain gage whose response to strain is a change in electrical capacitance which is predictably related to that strain.

3.2.3 *conditioning circuit*—a circuit or instrument subsystem that applies excitation to a strain gage, detects an electrical change in the strain gage, and provides a means for converting this change to an output that is related to strain in the test article. The conditioning circuit may include one or more of the following: bridge completion circuit, signal amplification, zero adjustment, excitation adjustment, calibration, and gain (span) adjustment.

3.2.4 *compensating gage*—a gage element that is subject to the same environment as the active gage element, and which is placed in the adjacent leg of a Wheatstone bridge to provide thermal, pressure, or other compensation in the strain gage system.

3.2.5 *electrical simulation*—a method of calibration whereby a known voltage is generated at the input of an amplifier, equivalent to the voltage produced by a specific amount of strain.

3.2.6 *free filament gage*—a resistive strain gage made from a continuous wire or foil filament which is fixed to the test article along the entire length of the gage, and which is supplied without a permanent matrix.

3.2.7 *gage factor*—the ratio between the unit change of strain gage resistance due to strain and the measurement. The gage factor is dimensionless and is expressed as follows:

<sup>3</sup> *Annual Book of ASTM Standards*, Vol 03.01.

$$K = \frac{R - R_o}{R_o} / \frac{L - L_o}{L_o} = \frac{\Delta R}{R_o} / \epsilon \quad (1)$$

where:

- $K$  = gage factor,
- $R$  = strain gage resistance at test strain,
- $R_o$  = strain gage resistance at zero or reference strain,
- $L$  = test structure length under the strain gage at test strain,
- $L_o$  = test structure length under the strain gage at zero or reference strain,
- $\Delta R$  = change in strain gage resistance when strain is changed from zero (or reference strain) to test strain, and
- $\epsilon$  = mechanical strain  $\frac{L - L_o}{L_o}$

3.2.8 *integral lead wire*—a lead wire or portion of a lead wire that is furnished by a gage manufacturer as part of the gage assembly.

3.2.9 *linearity*—the value measured as the maximum deviation between an actual instrument reading and the reading predicted by a straight line drawn between upper and lower calibration points, usually expressed as a percent of the full scale of the sensor range.

3.2.10 *lead wire*—a conductor used to connect a sensor to its instrumentation.

3.2.11 *matrix*—an electrically nonconductive layer of material used to support a strain gage grid. The two main functions of a matrix are to act as an aid for bonding the strain gage to a structure and as an electrically insulating layer in cases where the structure is electrically conductive.

3.2.12 *resistive strain gage*—a strain gage whose response to strain is a change in electrical resistance that is predictably related to that strain.

3.2.13 *shunt calibration*—a method of calibration whereby a resistor or capacitor of known value is placed electrically in parallel with another resistor or capacitor in a circuit, causing a calculable change in the total resistance or capacitance that is predictably related to a specific amount of strain.

3.2.14 *strain, linear*—the unit elongation induced in a specimen either by a stress field (mechanical strain) or by a temperature change (thermal expansion).

3.2.15 *strain gage system*—the sum total of all components used to obtain a strain measurement. May include a strain gage; a means of attaching the strain gage to the test articles; lead wires; splices; lead-wire attachments; signal-conditioning and read-out instrumentation; data-logging system; calibration and control system; environmental protection; or any combination of these and other elements required for the tests.

3.2.16 *static strain*—a strain that is measured relative to a constant reference value, as opposed to dynamic strain, which is the peak-to-peak value of a cyclic phenomenon, without reference to a constant zero or reference value (Fig. 1).

3.2.17 *test article*—an item to which a strain gage system is installed for the purpose of measuring strain in that item.

3.2.18 *thermal compensation*—the process by which the thermal output of a gage system is counteracted through the use of one or more supplementary devices, such as a thermocouple

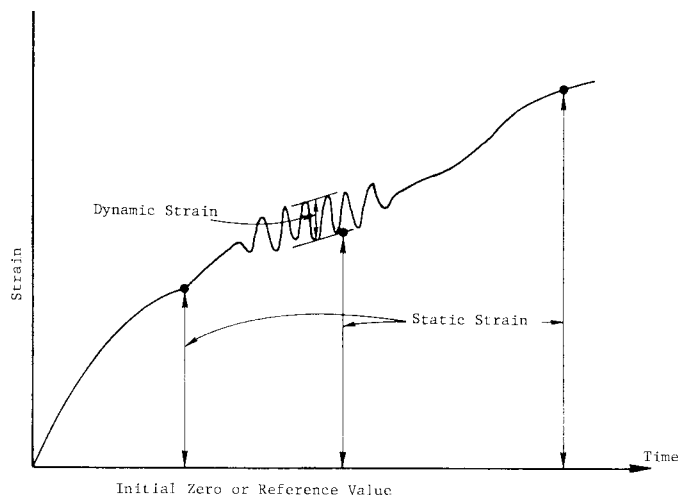

**FIG. 1 Relationship Between Static and Dynamic Strain**

or compensating gage. The counteraction may be integral to the gage system or may be accomplished by data processing methods, or both.

3.2.19 *thermal output*—the reversible part of the temperature induced indicated strain of a strain gage installed on an unrestrained test specimen when exposed to a change in temperature.

3.2.20 *thermal output-unmounted*—the reversible part of the temperature induced indicated strain of an unmounted strain gage when exposed to a change in temperature.

## 4. Significance and Use

4.1 The use of this guide is voluntary and is intended for use as a procedures guide for selection and application of specific types of strain gages for high-temperature installations. No attempt is made to restrict the type of strain gage types or concepts to be chosen by the user. The provisions of this guide may be invoked in specifications and procedures by specifying those which shall be considered mandatory for the purpose of the specific application. When so invoked, the user shall include in the work statement a notation that provisions of this guide shown as recommendation shall be considered mandatory for the purposes of the specification or procedure concerned, and shall include a statement of any exceptions to or modifications of the affected provisions of this guide.

## 5. Gage Selection Criteria

5.1 The factors listed in this section must be considered when selecting a strain gage system for use in the temperature range specified in 1.1. It is recognized that no gage may have all of the desired capabilities to meet all requirements of a particular test. The risk of compromising certain test objectives must be evaluated, and some test objectives may have to be modified to match the capabilities of the available gage selected. Guidelines for this evaluation are provided in Section 9.

### 5.2 Operating Temperature:

5.2.1 *Isothermal Tests*—Stability of the reference value with respect to time is essential when tests are to be made at constant temperature. The stability of the candidate gage



system at the specified temperature must be such that any shift that occurs in the reference value is tolerable for the duration of the test.

**5.2.2 Thermal Compensation and Transients**—The adequacy of the thermal compensation must be considered when the measurement of strain during a thermal transient is required. Thermal output is a function of temperature, thus its value at a temperature depends not only on temperature, but on the temperature history followed in reaching that temperature. If significant hysteresis in the thermal response is present, large errors or uncertainties can result. This is especially true when the calibration procedure used to characterize the thermal output does not accurately reflect the temperature sequence to which the gages will be exposed during testing. If the response time of the compensation is exceeded, the resulting uncertainty must be considered. The ability of the gage system to withstand the transient without a detrimental shift of the reference value must be verified. This is true whether or not strain is measured during the transient. Any gage factor change as a function of temperature change must also be considered.

**5.2.3 Pre-calibration:**

**5.2.3.1 Thermal output calibration on the structure** is usually not possible and pre-calibration of gages on a similar material is necessary. However, variations of up to 0.5 ppm/°F are possible within a material. Often, rolling direction will influence thermal expansion coefficient.

**5.2.3.2 Pre-calibration of resistive or capacitive strain gages** is performed using a calibration fixture made from material similar to the test article. The calibration fixture must be made to precisely fit the gage, especially if curvature is involved. Experience has shown mating parts must be lapped together to provide uniform clamping pressure around the periphery of the gage weld area.

**5.2.3.3 The calibration test** should be repeated to ensure precise duplication of the calibration. Zero return should also repeat exactly. If calibration data does not repeat; either the calibration set-up or the gages are faulty.

**5.2.4 Post Test Calibration:**

**5.2.4.1 A more precise thermal output calibration** can be achieved after the test by removing the test gage (cut it out of the structure) and running a precision test on the test gage still attached to the test article material. The test coupon is relieved of all induced stresses (thermal, mechanical, residual) and is free to expand freely with temperature. The integral gage lead wire should be exposed to thermal gradients similar to those that occurred during the test program.

**5.3 Duration of Test**—The ability of all parts of the gage system to function for the specified duration of test should be demonstrated; if multiple tests are required on the same test article, the capability and effect of gage replacement must also be established.

**5.4 Strain Rate**—The time response of the candidate gage system must be adequate to meet test requirements if rapid changes of load are anticipated. It may be necessary to design the loading rate of the test to accommodate limitations of the strain measurement system selected.

**5.5 Environment**—Some gages are limited to specific operating environments and therefore, the gage system selected

must be capable of withstanding the environment in which it will operate. Such limitations must be carefully considered when selecting the gage system to be used. Factors such as pressure, vibration, radiation, magnetic fields, humidity, etc., must be considered. The ambient and test environments of the elements of the strain gage system must be considered in the selection of lead wires, connectors, instrumentation, and seals (when required).

**5.6 Strain Range:**

**5.6.1 Total Strain Range**—The maximum strain ranges of the candidate gage types must be defined and must be adequate for the test. Mechanical strain attenuators, when permissible, may be added to extend the strain range of a given strain gage system, subject to the limitation of 5.6.2.

**5.6.2 Resolution**—The ability of the candidate gage to measure small increments of strain within the total strain range should be compared with the incremental strain measurement requirements of the test. When mechanical strain attenuators are used, the resulting loss of resolution must be considered.

**5.7 Strain Gradient**—The gage length of the candidate gage establishes the length over which the unit strain is averaged. This factor must be considered.

**5.8 Uncertainty Factor**—Uncertainty information that is available from the manufacturer must be considered, in conjunction with conditions which are unique to the test, in order to estimate the total uncertainty.

**5.9 Space Requirements**—If space on or adjacent to the test article is limited, the space requirements for the complete strain gage system may be a critical consideration in determining the suitability of a particular gage system. Working space for installation of the system may also be limited and must also be considered. Space adjacent to the installed strain gage should be provided for installation of room-temperature strain gages required for making in-place calibrations.

**5.10 Effects of the Strain Gage on the Test Article**—In most cases the reinforcing effect of the strain gage on the test article is negligible, particularly in the case of capacitance gages where the spring rate is extremely low. If a weldable gage is to be used on thin sections, an evaluation of the reinforcing effect should be made. Technical data concerning this effect can be obtained from a strain gage manufacturer.

**6. Characteristics of Available Gages**

**6.1 The two basic types of strain gages used for high temperature static strain measurements** are resistive strain gages and capacitive strain gages.

**6.1.1 Resistive gages** are usually small, low profile units superbly suited for dynamic strain measurements and relatively short-term static measurements. Because high temperatures cause metallurgical instability, oxidation, relaxation, and phase change of the strain sensing materials, all of which affect resistance change, resistive gages are generally not used for long-term measurements.

**6.1.2 Capacitive strain gages** are devices that measure changes in geometry and are unaffected by temperature or temperature changes, oxidation, relaxation, creep, grain growth, or phase change. They are best suited for measuring creep strains, or for very long-term tests on applications where a relatively large gage can be used, and when the gage will not

be subjected to high vibration, gravity, or acceleration forces, shock loading, or an electrically conductive atmosphere.

6.1.3 When selecting a specific strain gage for a given application, the strain gage system must be qualified for the specific conditions under which it will be required to operate and for the characteristics it must exhibit under service conditions. This section describes some of the capability of currently available strain gages, suitable for use in the specified temperature range, to meet the selection criteria of Section 5.

6.1.4 Wire and foil free-filament strain gages may be usable to approximately 400°C (750°F) under static conditions, and to approximately 1250°C (2280°F) for certain dynamic applications. However, the bonding methods used (ceramic cement, flame spray) are cumbersome and difficult to employ on large structures, particularly under field conditions. Ceramic cements require heat-curing and are generally unsuitable for large structures such as nuclear or fossil-fuel power-generating equipment. Flame spray is also difficult to use in the field. Free-filament gages, although useful for strain measurement on small items under laboratory conditions, are, therefore, not included in this practice. This does not preclude the use of these strain gages for specific tests based on the selection criteria of Section 5.

6.1.5 The gages described in this section have been used at high temperature for sufficient time and with sufficient success to warrant consideration in this guide. Each type has unique features, advantages, and limitations which must be carefully evaluated relative to the selection factors of Section 5.

#### 6.2 Bonded Weldable Resistance Strain:

6.2.1 This gage, shown in Fig. 2, consists of a free filament strain gage ceramic bonded to a shim. While it is not usually sealed or intended for underwater use, some hermetically sealed gages are bonded to the shim with ceramic cements or flame sprayed ceramics. The following alloys are available: (1) self temperature compensated nickel chrome alloy sensors useable to 340°C in quarter bridge (single element) configuration, (2) platinum tungsten and palladium chrome alloy sensors (dual element) compensated with platinum elements in half bridge configuration, and (3) iron chrome aluminum alloys having low temperature coefficient are available in half or full bridge configuration for applications where active-dummy combinations (slow temperature changes) are useable.

6.2.2 Except for long-term stability, the bonded strain gage has excellent performance with minimal hysteresis, small zero shift, long fatigue life, and accurate gage factor among its salient features. An integral weldable terminal and integral high temperature cable are usually supplied with these units, especially when the gages are supplied precalibrated for apparent strain.

6.2.3 The thermal output of the dual element gages can be adjusted to produce a zero output at any two selected temperatures. The thermal output of the platinum tungsten gage is

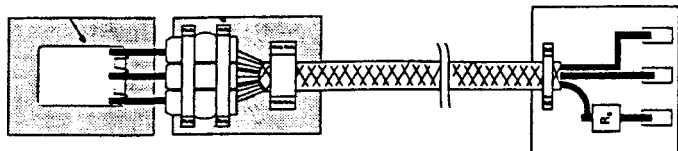

**FIG. 2 Bonded Weldable Resistance Strain Gage**

usually well within  $\pm 200 \mu\text{m/m}$  between 20 and 500°C. The shape of the thermal output curve is influenced by the thermal expansion characteristics of the test material. Fig. 3 shows the completion circuit for the dual element half bridge gage. There are two methods of compensation, (1) NASA method (20) and (2) the wire method (21).

6.2.4 With the NASA method, the gage is manufactured to fit a specific type of material with the platinum thermometer element resistance value selected to provide an almost perfectly balanced bridge. This permits a three wire cable to be used without sacrificing inherent lead wire compensation. The five wire system employs a thermometer element sufficiently high in resistance to compensate on virtually any material. This makes for universal compensation on any material. The drawback of this universal system is that five wires are required. A shunt resistor  $R_g$  placed across the thermometer element only shunts the output of the compensator. If the shunt resistor were placed across the thermometer and lead wire, inherent lead compensation would be sacrificed.

6.2.5 The user may precalibrate the gage and cable system and determine the bridge completion resistor values using a set of equations provided with the gage, or the gage may be precalibrated at the factory (22) and supplied precalibrated with the bridge completion resistors included in a network attached to the cool end of the cable. The user needs only to hook up the gage as a full bridge transducer and insert the calibration curve into his data acquisition system.

6.3 *Hermetic Weldable Resistance Strain Gage*—This gage, which is shown several times the actual size in Fig. 4, is hermetically sealed and furnished with integral lead wires, and may be used in a variety of severe environments at high temperature. The strain tube is welded to a thin mounting flange, which is welded to the surface of the test article, thus providing transfer of strain from the test article to the gage. Although Fig. 4 shows stainless steel strain tube, mounting flange, and cladding of the integral lead wire, other materials are available to meet the requirements of specific applications; consult the manufacturer for available materials. Within limits, the thermal output of the gage due to temperature can be adjusted to produce a zero output at any two selected temperatures by inserting a temperature compensation resistor,  $R_{tc}$  in Fig. 5 in series with either the active or compensating gage element; the proper resistor is furnished by the manufacturer. Because of the added resistance in series with one of the gage elements, the bridge-completion resistors must also be adjusted for balance by adding a balancing resistor ( $R_{bal}$  in Fig. 5) in the opposite half of the bridge. This resistor is also furnished by the

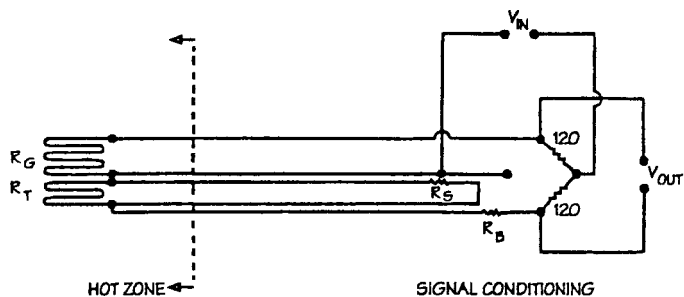

**FIG. 3 Five Wire Circuit**

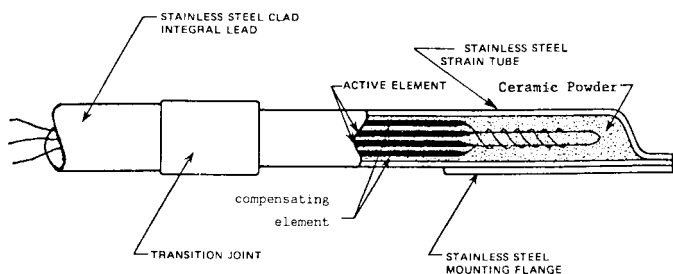

**FIG. 4 Hermetic Weldable Resistance Strain Gage**

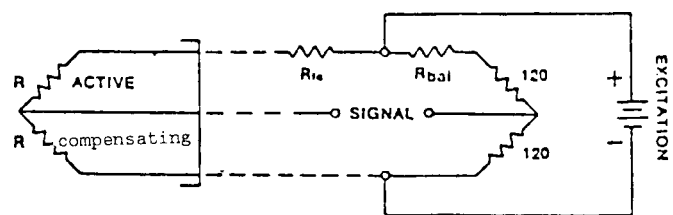

**FIG. 5 Bridge Completion Network and Power Supply**

gage manufacturer. The value of  $R_{bal}$  is based on the use of 120  $\Omega$  bridge-completion resistors to produce a balanced bridge when the gage is connected.

**6.3.1 Operating Temperature and Thermal Stability:**

6.3.1.1 The platinum tungsten element is essentially stable for short-term testing to 500°C (days) with shorter excursions up to 580°C (hours) without damage to the gage. Longer tests (weeks) can be run to up to 425°C. Beyond these limits is the domain of the capacitive strain gage.

6.3.2 *Thermal Compensation and Transients*—Thermal output characteristics must be considered for operation at varying temperatures. This information is furnished by the manufacturer for use of the gage on the material specified by the user. For precise evaluation, a calibration is necessary, with thermal output determined at the temperatures of interest. Temperatures should be measured by a thermocouple(s) mounted immediately adjacent to the gage. Thermal output and hysteresis of a test are usually repeatable under identical test conditions; however, even the slightest change in test conditions may result in a change of thermal output, hysteresis, or both. To qualify the gage for thermal shock, laboratory tests should be made to determine the stability characteristics and the limits of thermal compensation.

6.3.3 *Electrical Requirements*—Bridge completion, as shown in Fig. 5, is required. While there are several standard strain measuring systems with bridge completion capability available, it is recommended that, for static strain measurement in the temperature range of this practice, an individual signal conditioning circuit having the following features be provided for each gage.

6.3.4 *Excitation Power Supply*—A power supply for providing constant DC voltage, continuously variable from 1 V to 15 V across a 120  $\Omega$  external load, is required. Constant current excitation cannot be used with some of the compensation techniques generally used with this gage. If more than one bridge circuit is excited by the same power supply, the electrical configuration must provide electrical isolation of each circuit to protect it in the event of a direct short of the excitation of any of the adjacent circuits.

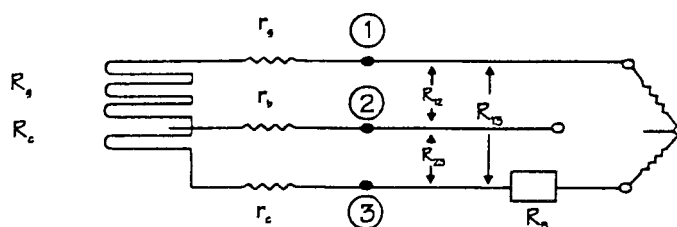

**FIG. 6 Three Wire Circuit**

TYPE	SG 425	MG 425
DIM. A	1.09	.62

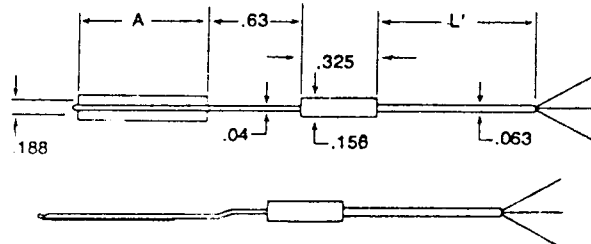

NOTE 1—All dimensions are in inches.

**FIG. 7 Dimensions of Hermetic Weldable Resistance Strain Gage**

6.3.5 *Balance Control*—Means shall be provided for balancing the bridge with a  $T$  balance resistor network across the completion half of the bridge. This is not required in the event that the data acquisition equipment automatically compensates for initial bridge unbalance.

6.3.6 *Shunt Calibration*—Shunt calibration capability should be provided on the completion half of the bridge. Shunting of the active or compensating legs of the bridge is not recommended because of changes in the resistances of the lead wires with temperature. Multiple shunt calibration is recommended.

6.3.7 *Circuit*—The signal conditioner must be capable of handling a half bridge circuit with precision completion resistors, configured to permit the addition of series balance resistors to either leg. It is recommended that the signal conditioner be able to accommodate a half bridge, five wire hookup, with two additional leads, for remote sensing of the excitation voltage.

6.3.8 Means must be provided for continuous monitoring of bridge excitations and bridge output. An amplifier may or may not be required, depending on the input capability of the measuring system used. Amplifier requirements are not covered in this guide; however, a good quality, stable amplifier with true differential input, and input impedance of not less than 10 M  $\Omega$  and shunted by 750 pF when DC-coupled, is recommended.

6.4 *Differential Capacitance Strain Gage*—Fig. 8 identifies major elements of the gage and shows principal dimensions. Fig. 9 shows an isometric view. The compensating rod (1) is usually made of the same material as the test article (specified by user). The cylindrical excitation plates (2) are mounted coaxially on, but are electrically insulated from the compensating rod. The sensing ring (3) is mounted coaxially with the excitation plates but is separated from them by an air gap. The

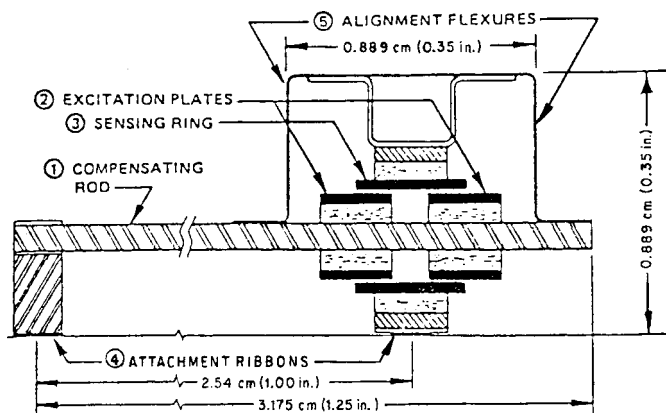

FIG. 8 Differential Capacitance Strain Gage

attachment ribbons (4), (see the isometric view in Fig. 9) provide means for welding the gage to the test article. The alignment flexures (5) (see the isometric view in Fig. 9), maintain the coaxial alignment of the sensing ring relative to the excitation plates and compensating rod. Leads from the three capacitor plates are brought to a terminal (6) which is also attached to the test article by spot welding. The complete strain measuring system consists of a half bridge differential capacitance strain gage, a capacitive signal conditioner, and the interconnecting leads.

6.4.1 With this type of gage, strain in the test article causes linear movement of the excitation plates relative to the colinear sensing ring. Changes in capacitance result when more or less area of the sensing ring overlaps the respective excitation plates; the linear gap between the excitation plates and the annular gap between the excitation rings and the sensing rings remain constant. Temperature compensation is achieved by use of a compensating rod made from a material having thermal expansion characteristics similar to those of the test article. Both the gage and the test article are instrumented with thermocouples to obtain data for computing the corrections required if there is a temperature difference between the compensating rod and the surface of the test article. These thermocouples (9) are shown in Fig. 9 and are connected to the thermocouple terminals (8), which are spot welded to the test article. Factors affecting gage selection are discussed in the following paragraphs.

6.4.2 *Operating Temperature and Thermal Stability*—The gage operates effectively over the entire 425°C to 650°C (800°F to 1200°F) range covered by this guide. Average drift rates for long term tests (2000 to 12 000 h) are typically from 0.01 to 0.05  $\mu\text{m}/\text{m}/\text{h}$  at approximately 640°C (1180°F). Short term drift rates can be up to 1  $\mu\text{m}/\text{m}/\text{h}$  during the first 100 h of operation.

6.4.3 *Thermal Compensation and Transients*—The gage has been used successfully at thermal transients of up to 17°C/seconds (30°F/seconds). For varying temperature conditions, thermal output should be generated in situ utilizing an integral surface thermocouple. Thermal output and hysteresis of a test are usually, within limits repeatable under identical test conditions. Even the slightest change in test conditions, however, may result in a change of apparent strain, hysteresis, or both.

6.4.4 *Life Expectancy*—Successful tests of more than

12 000 h duration have been reported. Cyclic fatigue data are not available (6).

6.4.5 *Strain Rate*—The gage is rated for less than 2 % nonlinearity to 30 000  $\mu\text{e}/\text{s}$  at 21°C (70°F) (4).

6.4.6 *Environmental Factors Other Than Temperature*—The gage has usually been used in air at atmospheric pressure, but has performed satisfactorily in helium, hydrogen, nitrogen, and an air-argon mixture of unknown composition. The experimenter should consult the manufacturer before attempting to use the system in gases other than those noted.

6.4.6.1 *Nuclear Radiation Resistance*—The gage contains no organic or other materials that will deteriorate under nuclear radiation.

6.4.6.2 *Magnetic Properties*—See Ref. (4).

6.4.7 *Strain Range*—The total rated strain range is 40 000  $\mu\text{e}$  for the 25.4 mm gage length Model, and 160 000  $\mu\text{m}/\text{m}$  for the 6.35 mm Model.

6.4.8 *Gage Length*—Strain is averaged over the active gage lengths of 25.4 mm (1 in.) and 6.35 mm (0.25 in.), respectively.

6.4.9 *Space Requirements*—Major dimensions of the gage are shown in Fig. 8 and Fig. 9. The user must install a sheet metal housing (furnished by the user) over the installed gage system.

6.4.10 *Electrical Requirements*—The electronics required for conversion of the gage differential capacitance output to an analog voltage was developed specifically for use with this gage. The system provides both an excitation to, and a calibrated output from the strain gage. Each module provides dual excitation signals at a carrier chosen to eliminate interference from line-frequency harmonics. The return signal from the gage is amplified at a calibrated set point and then is converted to a DC signal that is directly proportional to the displacement applied to the gage (that is, the strain). The use of a charge amplifier input eliminates the effect of signal lead wire-to-shield capacitance, minimizing sensitivity of the gage to lead wire length. This system has a full scale output of 5 V. The minimum strain in the gage to produce the full scale output of 5 V is 2500  $\mu\text{m}/\text{m}$ .

6.5 *Variable Capacitance Strain Gage*—Fig. 10 shows a cross section and major dimensions of this gage. It is a single capacitor, variable capacitance device that works on the principle that changes in gage length (the distance between the welds in Fig. 10) are mechanically amplified to produce a magnified movement of the electrodes relative to one another, normal to the plane of the electrodes, which causes a change in the air gap between the electrodes and thus the capacitance. The electrode plates are mounted on arches of different radii. Capacitance of this type of gage is typically between 0.4 and 1.5 pF over a working range of 10 000  $\mu\text{m}/\text{m}$ .

6.5.1 The capacitive output of this gage is nonlinear with strain as shown in Fig. 11, which illustrates the typical relationship obtained by calibrating the gage at room temperature. The gage is attached to the surface of the test article by single spot welds at each end (Fig. 10), and is made from a highly stable alloy with temperature coefficient matching closely either that of the stainless steels or ferritic steels used at elevated temperatures. However, there may be some thermal mismatch when the welded gage and the test item are heated,

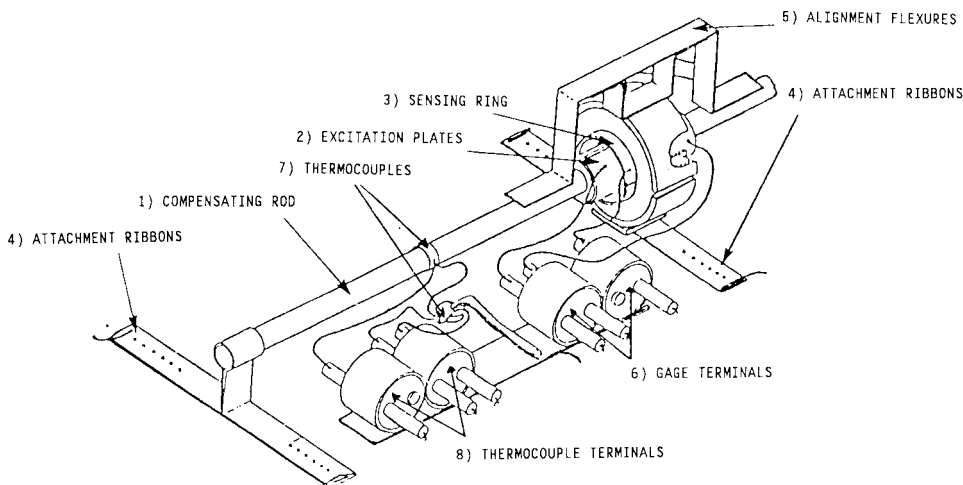

NOTE 1—Overall gage dimensions are 3.175 cm (1.25 in.) by 1.524 cm (0.60 in.)

**FIG. 9 Isometric View, Differential Capacitance Strain Gage**

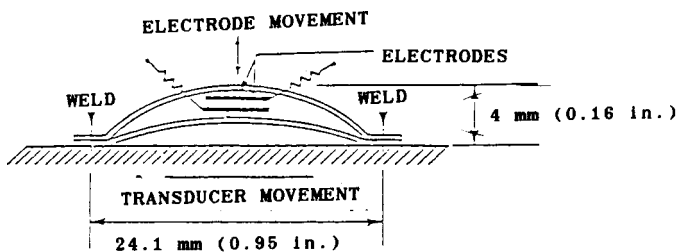

**FIG. 10 Variable Capacitance Strain Gage Showing Major Dimensions**

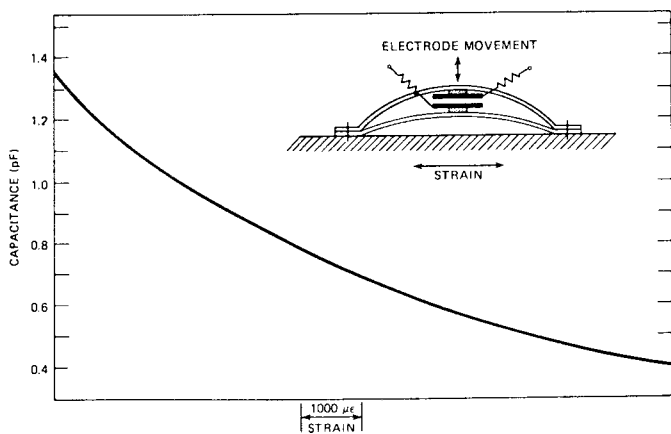

**FIG. 11 Variable Capacitance Strain Gage—Typical Response Curve**

resulting in a thermal output that must be either thermally compensated or accounted for by calculation. The gage intended for use on ferritic steels has an expansion coefficient of approximately  $10.8\mu^{\circ}\text{C}^{-1}$  ( $6\mu^{\circ}\text{F}^{-1}$ ). The gage used with stainless steels has an expansion coefficient of approximately  $16.2\mu^{\circ}\text{C}^{-1}$  ( $9\mu^{\circ}\text{F}^{-1}$ ). Characteristics of the variable capacitance gage, relative to gage qualification and selection, are discussed in the following paragraphs.

**6.5.2 Operating Temperature and Thermal Stability**—The gage operates effectively over the entire range of 425°C to 650°C (800°F to 1200°F) range covered by this guide. Average

systematic drift rates for long-term tests (2000 to 12 000 h) are typically from 0.01 to 0.04  $\mu\epsilon/\text{h}$  at approximately 600°C (1110°F). Short term drift rates can be as much as 0.5  $\mu\text{m}/\text{m}$  during the first 100 h.

**6.5.3 Thermal Compensation and Transients**—For varying temperatures, thermal output data should be generated in situ, utilizing a supplementary thermocouple on the surface of the test article adjacent to the gage. The gage can be used to measure strains during thermal transients as fast as 0.5°C/seconds (0.9°F/seconds) with thermal correction. Thermal output and hysteresis of a test are usually, within limits, repeatable under identical test conditions. Even the slightest change in test conditions, however, may result in a change of thermal output, hysteresis, or both.

**6.5.4 Life Expectancy**—Long life can be expected from the CERL-planer gage; tests have been successfully run for more than 40 000 h. Both types of gages have withstood in excess of 50 temperature cycles, each consisting of heating from 20°C to 600°C (68°F to 1112°F) over 4 h and cooling to approximately 25°C (78°F) over 16 h. Typical drift under these conditions is 5 to 10  $\mu\text{m}/\text{m}$  per cycle.

**6.5.5 Environmental Factors Other Than Temperature**—The gage has generally been used in clean air at atmospheric pressure.

**6.5.5.1 Nuclear Radiation Resistance**—The gage contains no organic or other materials which will deteriorate under nuclear radiation.

**6.5.5.2 Magnetic Properties**—See Ref. (5).

**6.5.6 Strain Range**—The rated strain range is  $\pm 5000\mu\text{m}/\text{m}$ . The gage may be adjusted to provide the full 10 000  $\mu\text{m}/\text{m}$  in one direction when installing it on the test article.

**6.5.7 Gage Length**—Strain is averaged over the active gage length of 19 mm (0.75 in.).

**6.5.8 Space Requirements**—Major dimensions of the gage profile are shown in Fig. 7. The gage is approximately 4 mm (0.16 in.) wide. Space must be allowed for the lead wires and for a protective sheet metal cover furnished by the manufacturer.

**6.5.9 Electrical Requirements**—A special transformer

bridge was developed (5) for use with this gage. The applied voltage is approximately 50 V, depending on the manner in which it is connected. This instrumentation is available as a single unit with switching units, or in scanning or multiplexing configurations. The differential capacitance instrumentation described in 6.4.10 can also be adapted for use with the variable capacitance strain gage (6).

## 7. Gage Installation

7.1 Capacitance-discharge welding is the preferred method of attaching all gages covered by this guide. While the use of capacitive-discharge welding normally creates no problems, it might create local discontinuities on the surface of the test article that could, under some circumstances, lead to premature failure of the test article. The potential for this must be investigated as part of the test design. Consult gage manufacturers for detailed installation procedures.

## 8. Test Program Design

8.1 Because of the many checks and calibrations required for successful high temperature strain measurement during every phase of a test, it is important that procedures be identified and specifically included in the test plan. As discussed in Section 5 relative to gage capabilities and selection, calibration requirements may sometimes conflict with test requirements. To aid in effective planning and to avoid compromising either test requirements or calibration needs, this section discusses checks and calibrations required to obtain and evaluate valid strain measurements.

8.2 *Pre-installation Consideration*—Basic behavioral characteristics and properties of the test article should be available when planning the test program. As a minimum, room temperature values and predicted variations within the test temperature range are needed for elastic modulus, Poisson's ratio, and coefficient of thermal expansion. This information is required for proper calibration of the strain gages and for interpretations and evaluation of strain data obtained from the test.

8.2.1 If the elastic limit is expected to be exceeded, some indication of the monotonic elastic-plastic stress-strain relationship of the material at the test temperature is needed. It is desirable to have some knowledge of the first-cycle thermal behavior and thermal history of the material if thermal cycling is not permitted on the test article prior to test. The potential for capacitive-discharge welding to adversely affect the surface of the test article must also be investigated (see Section 6).

8.3 *Strain Gage Checks and Characteristics*—Each gage should be carefully examined when received, as follows.

8.3.1 *Visual Inspection*—All gage components should be checked for damage or other structural irregularities. Specifically, for the capacitance gages, attention should be given to the internal wiring and alignment of the capacitive elements.

8.3.2 *Electrical Inspection*—Electrical continuity and insulation resistance of all conductors, to ground and to each other, should be checked for compliance with specification requirements; this data should be recorded for later comparison.

8.3.3 *Instrumentation Checkout*—Each conditioning circuit and its components should be checked for proper operation. It is recommended that a procedure for simulation of the antici-

pated gage input with a standard resistive or capacitive circuit be established to become familiar with instrument operation, independent of gage behavior.

8.3.4 *System Checkout*—A prototype system, including a gage mounted on a beam or other calibration device, representative lead wires, and instrumentation should be assembled for establishing basic room-temperature behavior of the system and for qualifying installation procedures and personnel. This step should not be omitted unless prior experience with the system has established a qualified procedure and personnel.

8.3.5 *Simulated Service Test*—If practicable, a checkout of the prototype system (8.3.4) should be made under simulated thermal and mechanical conditions of the test. This has been found to be highly desirable and, in some cases, essential to establish system competence and to eliminate costly errors in final installation and testing.

8.3.6 *Procedures*—Procedures for installing, calibrating, and operating system components are available from the manufacturers. Additional written procedures, specific to the particular strain gage system installation, should be developed for each step of installation, checkout, and operation. This is necessary to ensure consistent successful gage installation, qualification of personnel, and for proper evaluation of the test and evaluation of performance. Inspection, installation, and calibration data sheets and check lists are recommended.

8.4 *In-place Checks and Calibrations*—After the sensors have been installed and the lead wires connected, systematic checks and calibrations both before the start of and during testing are essential. These should be covered by detailed procedures and included in the test schedule. Such systematic checks may include the following:

8.4.1 *Resistance Gage*—Gage-resistance and resistance-to-ground measurements; shunt calibrations.

8.4.2 *Capacitance gages*—Total-capacitance and resistance-to-ground measurements; shunt calibrations.

8.4.3 *Channel Identification*—After the completion of installation checks, a final channel identification check should be made by mechanically or thermally loading each individual gage.

8.4.4 *Thermal Output*—Characterization of thermal output is necessary unless purely isothermal tests are planned. These determinations are recommended to establish repeatability and reference zero stability. In situ characterization is preferred. If this is not possible, precalibration of the gage is essential.

8.4.4.1 The test article should be thermally cycled, very slowly, to achieve uniform heating, and thermal output recorded. The process should be repeated until satisfactory repeatability is achieved; at least three cycles are usually necessary. Thermal output is a function of temperature. Its value at a temperature depends not only on temperature, but on the temperature history followed in reaching that temperature. If significant hysteresis in the thermal response is present, large errors or uncertainties can result. This is especially true when the calibration procedure used to characterize the thermal output does not accurately reflect the temperature sequence to which the gages will be exposed during testing.

8.4.4.2 Only the thermal output, as described in 3.2.19, can be compensated. Deformation due to magnetostriction, phase





change, nuclear irradiation, chemical change, etc., cannot be compensated for by the techniques of this practice.

8.4.5 *Sensitivity Calibration*—The user must recognize that gage factors and sensitivity data furnished by the manufacturer were measured under different conditions than may be encountered during test application and must be considered as only approximate. To minimize errors due to bending, torsion, lead wire, and biaxial effects, an in-place calibration in the elastic range is recommended. Precision foil strain gages should be installed adjacent to, and with the same orientation as the test gage(s). A mechanical loading (pressure or force) of known intensity is applied and the outputs of the two gages are compared. The sensitivity of the test gage(s) is adjusted to agree with the foil gage. Test gage outputs grossly different than the foil gage outputs are a problem to be investigated. When agreement between test-gage and foil-gage outputs is repeatable, reference calibration values from electrical simulation (for example, shunt calibration) should be recorded for periodic checks of the instrumentation beyond the gage terminals. The foil gages must be removed before the start of high temperature testing. Foil gages exposed to high temperatures will decompose and produce impurities which are detrimental to capacitance gages. For the most accurate data, the mechanical loading procedure should be repeated at test temperature, using the data obtained at room temperature (adjusted for the change in elastic modulus with temperature) to obtain a prediction of strain response. (This in-place calibration is only possible for structural tests on materials that are well characterized as to the elastic modulus as a function of temperature.) For long term tests, in-place calibrations and electrical simulation checks should be repeated at periodic intervals if the test conditions permit.

8.4.6 *Sensitivity Check*—A short-term stability test at constant temperature is advisable prior to loading, if the test conditions permit. Much of the drift associated with high temperature occurs during the first 50 to 100 h.

#### 8.5 *Post Test Checks and Calibrations:*

8.5.1 *In-Place Calibration*—The pretest and during-test calibrations and electrical simulations should be repeated on completion of the test and the results compared to the pretest and during-test results. New foil strain gages should be installed as described in 8.4.5. Where plastic strains were encountered during the test, the mechanical loadings may be increased to broaden the calibration range.

8.5.2 *Cumulative Strain Measurement*—Where feasible, before and after measurements at room temperature can be used to verify total displacement as indicated by the strain gage(s). This may be done by careful dimensional measurements between scribe lines or marks (made before the start of the test) using an optical or mechanical extensometer.

## 9. Evaluation of Data

9.1 The major factors to be considered when estimating uncertainties in high-temperature strain measurement are as follows:

9.1.1 Stability of reference zero; (gage and system drift), usually expressed as the drift rate ( $\mu\text{m/h}$ ). The uncertainty is determined by multiplying the drift rate by the duration of the test, and is evaluated as a percent of maximum strain.

9.1.2 Variation of gage sensitivity, expressed and evaluated as a percent of reading.

9.1.3 Repeatability, or the variation in strain measurements taken under repeated thermal or mechanical loads, expressed as a percent of maximum strain.

9.1.4 Combined hysteresis and linearity (repeatable), expressed as a percent of maximum strain.

9.1.5 Thermal output and heated lead wire effects, expressed in terms of  $\mu\theta r$  as percent of full scale of the gage.

9.1.6 Reference zero shift due to mechanical loading (a material effect particularly present on the first cycle) expressed in terms of  $\mu\theta r$  percent of maximum strain.

9.1.7 Reference zero shift due to thermal cycling (gage or material) expressed in terms of  $\mu\theta r$  percent of maximum strain.

9.1.8 Consideration of these effects on overall uncertainty varies, depending on the time and purpose of the evaluation.

9.2 *Evaluation Prior to Gage Selection*—Manufacturer's data and published user data (reports, technical papers, etc.) must be used to make a preliminary estimate of the total expected uncertainty associated with a strain measurement. This estimate can be improved upon with in situ calibrations. It is necessary only to select the most applicable strain gage and place a lower bound on the probability of successfully meeting test requirements. As mentioned in Section 5, the most applicable gage may not meet all test requirements; if these requirements cannot be modified to the gage capabilities, the simulated service test described in 8.3.4 becomes increasingly important in evaluating the uncertainties associated with exceeding the gage capabilities.

9.3 *Evaluation of Uncertainty After Prototype and Simulated Service Tests*—A more refined evaluation of overall uncertainties associated with a specific application can be made using data obtained in prototype and simulated service tests. Uncertainty bands which quantify the effects associated with combinations of factors can be established from this data. The "static uncertainty band," which combines error due to repeatability, hysteresis, and linearity, is established by repeated mechanical loadings at a constant temperature. The "thermal uncertainty band" is established by varying the uniform temperature at constant load, and measuring the variation in the indicated temperature compensated strain. The thermal uncertainty band combines the thermal effects on gage sensitivity, errors in temperature compensation, and lead wire effects. It also includes the effects due to change in Young's modulus with temperature, which can be factored out. A simplified overall uncertainty band can be established by overlaying the static uncertainty bands established at several temperatures of interest with the thermal uncertainty band. This uncertainty is usually expressed as a deviation from the best-fit calibration curve in terms of plus or minus percent of maximum strain. Time-dependent variations, such as drift, must be considered separately. If further refinement of the uncertainty analysis is required at this point, a statistical evaluation can be made by increasing the number of prototype gages calibrated in the laboratory. Because of the high cost of high-temperature strain gage installations, this step must be evaluated relative to the overall cost of the test program. Approaches to statistical evaluation and data reduction can be found in Refs. (7) and (9).



9.4 *Evaluation of Uncertainty from In Situ Calibrations*—The evaluation of the uncertainty bands discussed in 9.3 should, if possible, be conducted on the final test article after gage installation in order to establish a discrete best-fit calibration for each gage and its associated scatter band.

9.5 *Redundancy*—Multiple gage installations, measuring identical strains, should be considered where economically feasible. A minimum of two or three gages is recommended for short-term tests. One additional gage for each 2000 h of expected operation is desirable.

9.6 *Material Consideration*—Changes in material properties of the test article will occur with both load and thermal cycling. These changes cannot, in general, be compensated for in the strain gage, and must be accounted for separately.

## 10. Keywords

10.1 extensometer; high temperature testing; strain gage-adverse environment; strain gage-capacitive; strain gage-free filament; strain gage-high temperature; strain gage-installation; strain gage-selection; strain gage-weldable; stress

## REFERENCES

- (1) Hetenyi, Wiley, *Handbook of Experimental Stress Analysis*, 1950.
- (2) Perry, C. C., and Lissner, H. R., *The Strain Gage Primer*, 2nd Edition, MacGraw-Hill, 1962.
- (3) *Operation and Maintenance Manual*, Ailtech Weldable and Embeddable Integral Lead Strain Gages, Los Angeles, CA.
- (4) *Capacitive Strain Measuring System Manual*, Hitec Capacitive Strain Gage, Hitec Products, Inc., Ayre, MA.
- (5) *Operation and Maintenance Manual*, CERL Planer Capacitive Strain Transducer, G. V. Planer, Ltd., United Kingdom.
- (6) Smith, J. E., "Assessment of Current High-Temperature Strain Gages" *Oak Ridge National Laboratory Report ORNL/TM 7025*, December 1979.
- (7) "Performance Characteristics of Metallic Resistance Strain Gages," International Recommendation No. 62 of the International Organization of Legal Metrology, February 1981.
- (8) Hofstoetter, P., "Calibration of High Temperature Strain Gages with the Aid of Clamping Devices," *Experimental Mechanics*, June 1982.
- (9) Lipson, C., and Sheth, N., *Statistical Design and Analysis of Engineering Experiments*, MacGraw-Hill, 1973.
- (10) Jenkins, J. M., and Lemcoe, M. M., "Problems Associated with Attaching Strain Gages to Titanium Alloy Ti-6Al-4V," NASA TM-X-56004, February 1977.
- (11) Jenkins, J. M., "An Introduction to Thermal Effects in Strain Gage Load Measurement," NASA TX-3061, May 1974, pp. 1-27.
- (12) Imig, L. A., "Effect of Strain-Gage Attachment by Spotwelding and Bonding on Fatigue Behavior of Ti-6Al-4V, Rene 41, Inconel X," NASA TN D-5973, 1970.
- (13) Imig, L. A., "The Effect of Thermocouple Attachment by Spotwelding and by Adhesives Bonding on Fatigue Behavior of Ti-13V-11Cr-3Al and Ti-6Al-4V," NASA TM-X-2288, 1971.
- (14) Pettigrew, M. J., and Turner, R. B., "The Application of Strain Gages in Nuclear Environments," CANCAN Conference, Sherbrooke, Quebec, Canada, May 1979.
- (15) Nightingale, C. M., and Twa, G. J., "Evaluation of Precalibration Techniques for Ailtech SG-425 Strain Gages," proceedings Western Regional Strain Gage Committee, February 1982.
- (16) *Cases of the ASME Boiler and Pressure Vessel Code*, Case N252, "Low Energy Capacitive Discharge Welding Method for Temporary or Permanent Attachments to Components and Supports," American Society of Mechanical Engineers.
- (17) "High Temperature Capacitive Strain Measurement System," NASA Tech Brief B75-10069, May 1975.
- (18) Wnuk, S. P., "Progress in High Temperature and Radiation Resistant Strain Gage Development," Proceedings of the Spring Meeting of the Western Regional Strain Gage Committee, 1964.
- (19) Heather, C. W., Browne, R. J., and Der, T. J., "Application of CERL-Planer High-Temperature Strain Gages for the Measurements of Hoop Strains in Tubular Components," Central Electricity Generating Board, Southeast Region, SSD/SE/RN/79, April 1979.
- (20) Lei, J. H., Englund, D. R., and Croom, C., "The Temperature Compensation Techniques for a Pd Cr Resistance Strain Gage," SEM Fall Conference, 1991.
- (21) Wnuk, S. P., Jr., Law, M. E., and MacLean, J. G., "Development of Strain and Temperature Measurement Techniques for Use in Combined Thermal Acoustic Environment," AD B00924-4 NTIS, Springfield, VA, October, 1974.
- (22) Wnuk, S. P. Jr., and Wunk, V. P., "The Development of a Pd Cr Integral Weldable Strain Measurement System Based on NASA Lewis Pd Cr/PT Strain Sensor for User-Friendly Elevated Temperature Strain Measurements," Final Report on NASA Lewis Order #C-86401-D, 8-12-96.
- (23) Corum, J. M., and Baptiste, R. L., "Predictability of Long-Term Creep and Rupture in a Nozzle-to-Sphere Vessel Model," ASME PVC-Vol 230 Stress Classification, Robust Methods, and Elevated Temperature Design, ASME 1992.

*ASTM International takes no position respecting the validity of any patent rights asserted in connection with any item mentioned in this standard. Users of this standard are expressly advised that determination of the validity of any such patent rights, and the risk of infringement of such rights, are entirely their own responsibility.*

*This standard is subject to revision at any time by the responsible technical committee and must be reviewed every five years and if not revised, either reapproved or withdrawn. Your comments are invited either for revision of this standard or for additional standards and should be addressed to ASTM International Headquarters. Your comments will receive careful consideration at a meeting of the responsible technical committee, which you may attend. If you feel that your comments have not received a fair hearing you should make your views known to the ASTM Committee on Standards, at the address shown below.*

*This standard is copyrighted by ASTM International, 100 Barr Harbor Drive, PO Box C700, West Conshohocken, PA 19428-2959, United States. Individual reprints (single or multiple copies) of this standard may be obtained by contacting ASTM at the above address or at 610-832-9585 (phone), 610-832-9555 (fax), or service@astm.org (e-mail); or through the ASTM website (www.astm.org).*