



Designation: E 1681 – 99<sup>ε1</sup>

# Standard Test Method for Determining Threshold Stress Intensity Factor for Environment-Assisted Cracking of Metallic Materials<sup>1</sup>

This standard is issued under the fixed designation E 1681; the number immediately following the designation indicates the year of original adoption or, in the case of revision, the year of last revision. A number in parentheses indicates the year of last reapproval. A superscript epsilon ( $\epsilon$ ) indicates an editorial change since the last revision or reapproval.

<sup>ε1</sup> NOTE—Committee and Subcommittee jurisdictions were editorially revised in April 2000.

## 1. Scope

1.1 This test method covers the determination of the environment-assisted cracking threshold stress intensity factor parameters,  $K_{IEAC}$  and  $K_{EAC}$ , for metallic materials from constant-force testing of fatigue precracked beam or compact fracture specimens and from constant-displacement testing of fatigue precracked bolt-load compact fracture specimens.

1.2 This test method is applicable to environment-assisted cracking in aqueous or other aggressive environments.

1.3 Materials that can be tested by this test method are not limited by thickness or by strength as long as specimens are of sufficient thickness and planar size to meet the size requirements of this test method.

1.4 A range of specimen sizes with proportional planar dimensions is provided, but size may be variable and adjusted for yield strength and applied force. Specimen thickness is a variable independent of planar size.

1.5 Specimen configurations other than those contained in this test method may be used, provided that well-established stress intensity calibrations are available and that specimen dimensions are of sufficient size to meet the size requirements of this test method during testing.

1.6 *This standard does not purport to address all of the safety concerns, if any, associated with its use. It is the responsibility of the user of this standard to establish appropriate safety and health practices and determine the applicability of regulatory limitations prior to use.*

## 2. Referenced Documents

### 2.1 ASTM Standards:

D 1141 Specification for Substitute Ocean Water<sup>2</sup>

E 8 Methods for Tension Testing of Metallic Materials<sup>3</sup>

E 399 Test Method for Plane-Strain Fracture Toughness of Metallic Materials<sup>3</sup>

E 647 Test Method for Measurement of Fatigue Crack Growth Rates<sup>3</sup>

E 1823 Terminology Relating to Fatigue and Fracture Testing<sup>3</sup>

G 1 Practice for Preparing, Cleaning, and Evaluating Corrosion Test Specimens<sup>4</sup>

G 5 Standard Reference Method for Making Potentiostatic and Potentiodynamic Anodic Polarization Measurements<sup>4</sup>

G 15 Terminology Relating to Corrosion and Corrosion Testing<sup>4</sup>

## 3. Terminology

### 3.1 Definitions:

3.1.1 For definitions of terms relating to fracture testing used in this test method, refer to Terminology E 1823.

3.1.2 For definitions of terms relating to corrosion testing used in this test method, refer to Terminology G 15.

3.1.3 *stress-corrosion cracking (SCC)*—a cracking process that requires the simultaneous action of a corrodent and sustained tensile stress.

3.1.4 *stress intensity factor threshold for plane strain environment-assisted cracking ( $K_{IEAC}[FL^{-3/2}]$ )*—the highest value of the stress intensity factor ( $K$ ) at which crack growth is not observed for a specified combination of material and environment and where the specimen size is sufficient to meet requirements for plane strain as described in Test Method E 399.

3.1.5 *stress intensity factor threshold for environment-assisted cracking ( $K_{EAC}[FL^{-3/2}]$ )*—the highest value of the stress intensity factor ( $K$ ) at which crack growth is not observed for a specified combination of material and environment and where the measured value may depend on specimen thickness.

3.1.6 *physical crack size ( $a_p[L]$ )*—the distance from a reference plane to the observed crack front. This distance may represent an average of several measurements along the crack

<sup>1</sup> This test method is under the jurisdiction of ASTM Committee E-8 on Fatigue and Fracture and is the direct responsibility of Subcommittee E08.06 on Crack Growth Behavior.

Current edition approved April 10, 1999. Published August 1999. Originally published as E 1681 - 95. Last previous edition E 1681 - 95.

<sup>2</sup> *Annual Book of ASTM Standards*, Vol 11.02.

<sup>3</sup> *Annual Book of ASTM Standards*, Vol 03.01.

<sup>4</sup> *Annual Book of ASTM Standards*, Vol 03.02.

front. The reference plane depends on the specimen form, and it is normally taken to be either the boundary or a plane containing either the loadline or the centerline of a specimen or plate. The reference plane is defined prior to specimen deformation.

3.1.7 *original crack size* ( $a_o[L]$ )—the physical crack size at the start of testing.

3.1.8 *original uncracked ligament* ( $b_o[L]$ )—distance from the original crack front to the back edge of the specimen ( $b_o = W - a_o$ ).

3.1.9 *specimen thickness* ( $B[L]$ )—the side-to-side dimension of the specimen being tested.

3.1.10 *tensile strength* ( $\sigma_{TS}[FL^{-2}]$ )—the maximum tensile stress that a material is capable of sustaining. Tensile strength is calculated from the maximum force during a tension test carried to rupture and the original cross-section area of the specimen.

### 3.2 *Definitions of Terms Specific to This Standard:*

3.2.1 *environment-assisted cracking* (EAC)—a cracking process in which the environment promotes crack growth or higher crack growth rates than would occur without the presence of the environment.

3.2.2 *normalized crack size* ( $a/W$ )—the ratio of crack size,  $a$ , to specimen width,  $W$ . Specimen width is measured from a reference position such as the front edge in a bend specimen or the loadline in the compact specimen to the back edge of the specimen.

3.2.3 *yield strength* ( $\sigma_{YS}[FL^{-2}]$ )—the stress at which a material exhibits a specific limiting deviation from the proportionality of stress to strain. This deviation is expressed in terms of strain.

NOTE 1—In this test method, the yield strength determined by the 0.2 % offset method is used.

3.2.4 *effective yield strength* ( $\sigma_Y[FL^{-2}]$ )—an assumed value of uniaxial yield strength that represents the influences of plastic yielding upon fracture test parameters. For use in this method, it is calculated as the average of the 0.2 % offset yield strength  $\sigma_{YS}$ , and the ultimate tensile strength,  $\sigma_{TS}$ , or

$$\sigma_Y = (\sigma_{YS} + \sigma_{TS}) / 2 \quad (1)$$

3.2.5 *notch length* ( $a_n(L)$ )—the distance from a reference plane to the front of the machined notch. The reference plane depends on the specimen form and normally is taken to be either the boundary or a plane containing either the loadline or the centerline of a specimen or plate. The reference plane is defined prior to specimen deformation.

## 4. Summary of Test Method

4.1 This test method involves testing of single-edge notched [SE(B)] specimens, compact [C(T)] specimens, or bolt-load compact [MC(W)] specimens, precracked in fatigue. The single-edge notched beam specimen is tested by dead weight loading. An environmental chamber is either attached to the specimen, or the specimen is contained within the chamber. The chamber must enclose the portion of the specimen where the crack tip is located. Prescribed environmental conditions must be established and maintained within the chamber at all times during the test.

4.1.1 Specimens shall be deadweight loaded or otherwise

held under constant force or held under constant displacement (defined in 6.2) for a prescribed length of time, during which failure by crack growth leading to fracture may or may not occur.  $K_{IEAC}$  and  $K_{EAC}$  are defined as the highest value of stress intensity factor at which neither failure nor crack growth occurs. The stress intensity factor ( $K$ ) is calculated from an expression based on linear elastic stress analysis. To establish a suitable crack-tip condition for constant force tests, the stress-intensity level at which the fatigue precracking of the specimen is conducted is limited to a value substantially less than the measured  $K_{IEAC}$  or  $K_{EAC}$  values. For constant displacement tests, the stress-intensity level at which the fatigue precracking of the specimen is conducted is limited to the requirements of Test Method E 399. The validity of the  $K_{IEAC}$  value determined by this test method depends on meeting the size requirements to ensure plane strain conditions, as stated in Test Method E 399. The validity of the  $K_{EAC}$  value depends on meeting the size requirements for linear elastic behavior, as stated in the Test Method E 647.

4.1.2 This test method can produce information on the onset of environment-assisted crack growth. Crack growth rate information can be obtained after crack nucleation, but the method for obtaining this information is not part of this test method (1).<sup>5</sup>

4.2 The mechanisms of environment-assisted cracking are varied and complex. Measurement of a  $K_{EAC}$  or  $K_{IEAC}$  value for a given combination of material and environmental provides no insight into the particular cracking mechanism that was either operative or dominant. Two prominent theories of environment-assisted cracking are anodic reaction and hydrogen embrittlement (2). The data obtained from this test method may be interpreted by either theory of environment-assisted cracking.

4.3 Specimen thickness governs the proportions of plane strain and plane stress deformation local to the crack tip, along with the environmental contribution to cracking. Since these chemical and mechanical influences cannot be separated in some material/environment combinations, thickness must be treated as a variable. In this test method, however, the stress in the specimen must remain elastic. For these reasons, two threshold values of EAC are defined by this test method. The measurement of  $K_{IEAC}$  requires that the thickness requirements of plane strain constraint are met. The less restrictive requirements of  $K_{EAC}$  are intended for those conditions in which the results are a strong function of the thickness of the specimen and the application requires the testing of specimens with thickness representative of the application.

4.4 A variety of environmental (temperature, environment composition, and electrode potential, for example) and metallurgical (yield strength, alloy composition, and specimen orientation) variables affect  $K_{EAC}$  and  $K_{IEAC}$ .

## 5. Significance and Use

5.1 The parameters  $K_{EAC}$  or  $K_{IEAC}$  determined by this test method characterize the resistance to crack growth of a

<sup>5</sup> The boldface numbers in parentheses refer to the list of references at the end of this standard.

material with a sharp crack in specific environments under loading conditions in which the crack-tip plastic region is small compared with the crack depth and the uncracked ligament. The less restrictive thickness requirements of  $K_{EAC}$  are intended for those conditions in which the results are a strong function of the thickness of the specimen and the application requires the testing of specimens with thickness representative of the application. Since the chemical and mechanical influences cannot be separated, in some material/environment combinations, the thickness must be treated as a variable. A  $K_{EAC}$  or  $K_{IEAC}$  value is believed to represent a characteristic measurement of environment-assisted cracking resistance in a precracked specimen exposed to an environment under sustained tensile loading. A  $K_{EAC}$  or  $K_{IEAC}$  value may be used to estimate the relationship between failure stress and defect size for a material under any service condition, where the combination of crack-like defects, sustained tensile loading and the same specific environment would be expected to occur. (Background information concerning the development of this test method can be found in Refs (3-18).

5.1.1 The apparent  $K_{EAC}$  or  $K_{IEAC}$  of a material under a given set of chemical and electrochemical environmental conditions is a function of the test duration. It is difficult to furnish a rigorous and scientific proof for the existence of a threshold (4, 5). Therefore, application of  $K_{EAC}$  or  $K_{IEAC}$  data in the design of service components should be made with awareness of the uncertainty inherent in the concept of a true threshold for environment-assisted cracking in metallic materials (6, 18). A measured  $K_{EAC}$  or  $K_{IEAC}$  value for a particular combination of material and environment may, in fact, represent an acceptably low rate of crack growth rather than an absolute upper limit for crack stability. Care should be exercised when service times are substantially longer than test times.

5.1.2 The degree to which force deviations from static tensile stress will influence the apparent  $K_{EAC}$  or  $K_{IEAC}$  of a material is largely unknown. Small-amplitude cyclic loading, well below that needed to produce fatigue crack growth, superimposed on sustained tensile loading was observed to significantly lower the apparent threshold for stress corrosion cracking in certain instances (7, 8). Therefore, caution should be used in applying  $K_{EAC}$  or  $K_{IEAC}$  data to service situations involving cyclic loading. In addition, since this standard is for static loading, small-amplitude cyclic loading should be avoided during testing.

5.1.3 In some material/environment combinations, the smaller the specimen, the lower the measured  $K_{EAC}$  value, while in other material/environment combinations the measured  $K_{IEAC}$  value will be the lowest value (5, 9, 10, 11, 12). If, for the material/environment combination of interest, it is not known which specimen size will result in the lower measured value, then it is suggested that the use of both specimen sizes should be considered; that is, specimens with thicknesses representative of the application and specimens in which the thickness meets the requirements (see 7.2.1) of a  $K_{IEAC}$  value.

5.1.3.1 The user may optionally determine and report a  $K_{EAC}$  value or a  $K_{IEAC}$  value. The specimen size validity requirements for a  $K_{EAC}$  value meet the size requirements

developed for Test Method E 647 to achieve predominately elastic behavior in the specimen. Test Method E 647 size requirements for compact specimens should be applied to both the compact specimen and the beam specimen. The specimen size validity requirements for a  $K_{IEAC}$  value meet the size requirements developed for plane strain conditions for Test Method E 399.

5.1.4 Evidence of environment-assisted crack growth under conditions that do not meet the validity requirements of 7.2 may provide an important indication of susceptibility to environmental cracking but cannot be used to determine a valid  $K_{EAC}$  value (14).

5.1.5 Environment-assisted cracking is influenced by both mechanical and electrochemical driving forces. The latter can vary with crack depth, opening, or shape and may not be uniquely described by the fracture mechanics stress intensity factor. As an illustrative example, note the strong decrease reported in  $K_{ISCC}$ <sup>6</sup> with decreasing crack size below 5 mm for steels in 3 % NaCl in water solution (15). Geometry effects on  $K$  similitude should be experimentally assessed for specific material/environment systems. Application modeling based on  $K_{EAC}$  similitude should be conducted with caution when substantial differences in crack and specimen geometry exist between the specimen and the component.

5.1.6 Not all combinations of material and environment will result in environment-assisted cracking. In general, susceptibility to aqueous stress-corrosion cracking decreases with decreasing material strength level. When a material in a certain environment is not susceptible to environment-assisted cracking, it will not be possible to measure  $K_{EAC}$  or  $K_{IEAC}$ . This method can serve the following purposes:

5.1.6.1 In research and development, valid  $K_{EAC}$  or  $K_{IEAC}$  data can quantitatively establish the effects of metallurgical and environmental variables on the environment-assisted cracking resistance of materials.

5.1.6.2 In service evaluation, valid  $K_{EAC}$  or  $K_{IEAC}$  data can be utilized to establish the suitability of a material for an application with specific stress, flaw size, and environmental conditions.

5.1.6.3 In acceptance and quality control specifications, valid  $K_{EAC}$  or  $K_{IEAC}$  data can be used to establish criteria for material processing and component inspection.

5.1.7 Test results will be affected by force relaxation in constant displacement bolt-loaded compact specimens for some material/environment conditions. For relatively low strength material, non-aggressive environments, or high test temperatures, force relaxation can occur independently from environment-assisted cracking. Significant force relaxation would make cracking results difficult to interpret. If force relaxation is suspected of influencing the data, the following trial specimen test is recommended. Test a trial specimen with all the test conditions of interest, except with no environment applied. Monitor the force on the sample using a bolt with an electronic load cell attached. Instrumented bolts of this type are commercially available. A force relaxation of more than 5 %

<sup>6</sup>  $K_{ISCC}$  has been used in the literature as a special case of  $K_{IEAC}$  in which the crack growth is known to be due to the simultaneous action of a stress and a corrodent.

after 24 h indicates that the constant displacement test method may not be suitable for these test conditions, and a constant force test should be considered.

5.1.8 Residual stresses can have an influence on environment-assisted cracking. The effect can be significant when test specimens are removed from material in which complete stress relief is impractical, such as weldments, as-heat-treated materials, complex wrought parts, and parts with intentionally produced residual stresses. Residual stresses superimposed on the applied stress can cause the local crack-tip stress-intensity factor to be different from that calculated from externally applied forces or displacements. Irregular crack growth during precracking, such as excessive crack front curvature or out-of-plane crack growth, often indicates that residual stresses will affect the subsequent environment-assisted crack growth behavior. Changes in the zero-force value of crack-mouth-opening displacement as a result of precrack growth is another indication that residual stresses will affect the subsequent environment-assisted crack growth.

5.1.9 For bolt loaded specimens, the user should realize that material being tested at a non-ambient temperature may have a different displacement-to-force ratio from that at ambient temperature, and also the bolt material may have a different coefficient of thermal expansion from that of the material being tested. Care should be taken to minimize these effects.

## 6. Apparatus

### 6.1 Fixtures:

6.1.1 *Beam Specimens*—Specimens should be loaded with one end clamped in a stable rigid fixture and the other end clamped to a horizontal moment arm to which a force is applied. In a fixture of this type, the long axis of the specimen is placed horizontally with the notch opening upward. A schematic representation of a suitable loading fixture is given in Fig. 1. Note that limits are placed on the proximity of fixture contact points to the specimen notch and on the length of the moment arm. The fixture should have enough stiffness to ensure that moment arm deflection under force application is

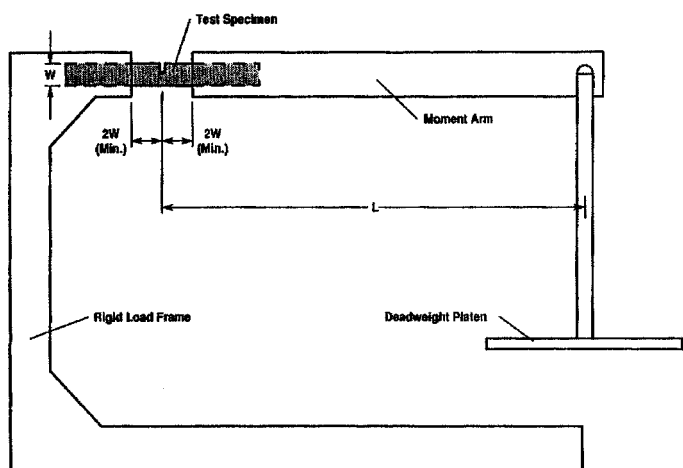

NOTE 1—The length of the moment arm (L) should be equal to or greater than 8W

**FIG. 1 Typical Configuration of a Dead-Weight Beam Loading Fixture**

primarily caused by test specimen compliance. In situations in which a single loading fixture simultaneously accommodates multiple specimens, it is important that the loading fixture be rigid enough to minimize transmission of transient deflections from specimen to specimen through the fixture.

6.1.2 *Compact Specimens*—A loading clevis suitable for constant force testing of compact specimens is shown in Fig. 2. Both ends of the specimen are held in a clevis and loaded through pins to allow rotation of the specimen during testing. To provide rolling contact between the loading pins and the clevis holes, the holes are machined with small flats on the loading surface. Other clevis designs may be used if it can be demonstrated that they will accomplish the same result.

6.1.3 *Bolt-Load Compact Specimens*—A test arrangement suitable for constant-displacement testing of bolt-load compact specimens is shown in Fig. 3. The displacement is applied to the specimen containing a machined notch and fatigue precrack. The displacement is applied with a bolt tightened against a flattened pin and measured with an electronic crack-mouth-opening-displacement (CMOD) gage (see Test Method E 399). Reference marks on the face of the specimen on both sides of the notch may also be used to verify the CMOD measurement of the applied displacement. The gage is attached to the specimen using integral knife edges machined into the specimen or using knife edges affixed to the specimen. Other types of gages and attachments may be used if it can be demonstrated that they will accomplish the same result. It is recommended that, if possible, the bolt pin be isolated from the environment and that an electric insulator be used between the bolt and pin. For some test conditions, environmental isolation and electrical insulation may not be possible.

### 6.2 Displacement Application:

6.2.1 *Constant-Force Specimens*—Specimens must be deadweight loaded or loaded so that the force remains constant

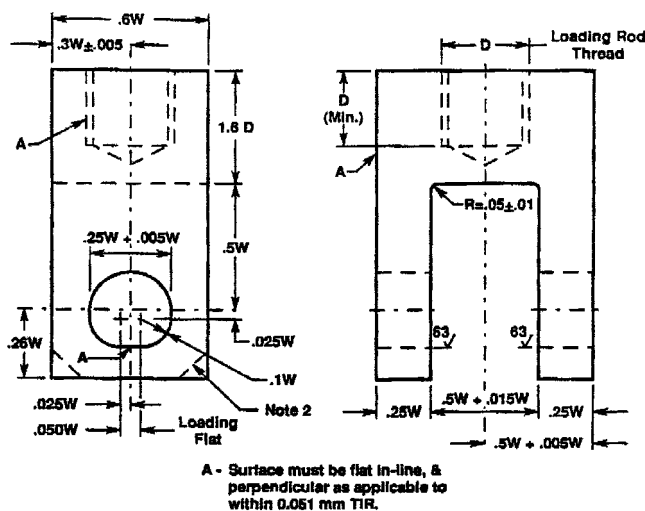

NOTE 1—Pin diameter =  $0.24W (+0.000W/-0.005W)$ . For Specimens a with  $\sigma_{vs} > 1379$  MPa the holes in the specimen and in the clevis may be  $0.3W (+0.005W/-0.000W)$  and the pin diameter =  $0.288W (+0.000W/-0.005W)$

NOTE 2—Corners of the clevis may be removed if necessary to accommodate a clip gage

**FIG. 2 Tension Test Clevis Design**

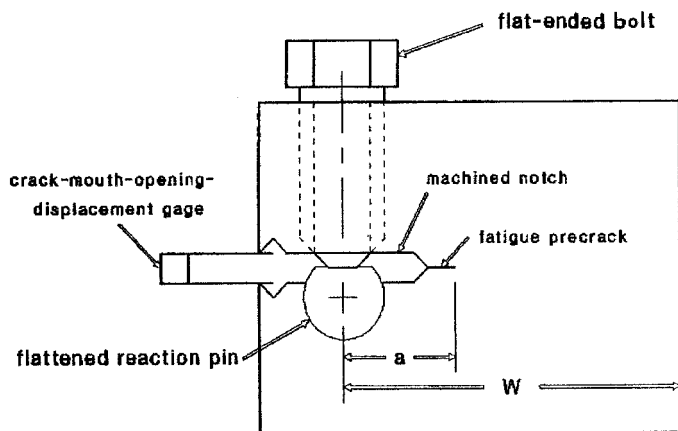

FIG. 3 Typical Test Arrangement for Constant Displacement  $K_{IEAC}$  Tests with Modified Bolt-Load Compact Specimen;  $H/W = 0.486$

throughout the test. Weights or a servo-controlled actuator are suitable for this purpose. A means must be provided to accurately measure the force, including the weight of the moment arm and associated load train fixtures. This may be done by including an electronic load cell in the load train or by using calibrated weights. The force applied to the specimen must be known, with an accuracy of  $\pm 1\%$  of the indicated reading. Overloads of more than 3% and repetitive force fluctuations of more than 1% must be avoided during the experiment. In addition, extraneous bending and torsional forces must be minimized (see 8.3).

6.2.2 *Constant Displacement Specimens*—The crack-mouth-opening-displacement applied to the bolt-load specimen must be known, with an accuracy of  $+1\%$  of the indicated reading. Overapplications of displacement of more than 5% and repetitive displacement fluctuations of more than 1% must be avoided during the experiment.

6.3 *Displacement Gauge*—It may be desirable to attach a displacement gage to a constant force specimen to detect crack growth during testing. It is required that a displacement gage be used with the constant displacement specimen to measure the amount of applied displacement (see 6.1.3). An electronic CMOD gage can provide a highly sensitive indicator of crack growth for this purpose (see Test Method E 399). However, when placed directly above an environmental chamber containing an aqueous solution for prolonged periods, corrosion may degrade CMOD gages. Also, the CMOD gage should not be allowed to come into direct contact with the solution to avoid possible galvanic action between the gage and the test specimen. A mechanical dial gage placed near the extremity of the moment arm also may be used to detect crack growth.

6.4 *Environmental Chamber*—It is important that the environmental chamber does not influence the test results either by modifying the environment or the electrochemical potential of the specimen. Influence of the environment chamber or the pressure of the environment should be accounted for in the calibration of the applied  $K$  value. The environmental chamber shall enclose the portion of the specimen that contains the crack tip. It shall be configured so that either the test specimen is the only metallic component in contact with the solution or the specimen is electrically isolated from any other metals in contact with the solution. Nonmetallic or corrosion resistant

materials are recommended for the environmental chamber. A sealant might be required between the specimen and the environmental chamber. Sealants selected must not alter the bulk solution chemistry of the test environment. It is recommended that the volume of the environmental chamber be large enough to contain at least  $40 \text{ mL/cm}^2$  of specimen surface area exposed to the solution.<sup>7</sup>

6.5 *Potentiostatic Control*—Where potentiostatic control of the specimen is desired, an electrochemical cell is required (including an auxiliary electrode, such as platinum or graphite, and a reference electrode with specimen potential controlled by a potentiostat). Care must be taken to avoid ground loops and galvanic interference from the clamping and loading fixtures. Oxides on the specimen surface may hamper the achievement of the desired specimen potential. Under some conditions, it may be necessary to mask off a portion of the specimen surface so that proper potentiostatic control can be achieved. It is desirable to include apparatus for measuring and recording electrode potential and applied current (Reference Method G 5).

## 7. Specimen Configuration, Size, and Preparation

### 7.1 Specimen Configuration:

7.1.1 The recommended beam specimen configuration is shown in Fig. 4. It is recommended that  $1 \leq W/B \leq 2$ , provided that  $B$ ,  $a_0$ , and  $W-a_0$  meet the validity criteria of 7.2. The specimen configuration shown in Fig. 4 does not include side grooves.<sup>8</sup>

NOTE 2—Caution should be exercised to avoid preferential crack growth near the side grooves when testing in more aggressive environments.

7.1.2 The recommended compact specimen configuration is shown in Fig. 5. The configuration does not include side grooves.<sup>8</sup> For the determination of  $K_{IEAC}$ , it is recommended that  $1 \leq W/B \leq 2$ , provided that  $B$ ,  $a_0$ , and  $W-a_0$  meet the validity criteria of 7.2.

7.1.3 The recommended bolt-load compact specimen configuration is shown in Fig. 6. The configuration does not

<sup>7</sup> The ratio of the specimen free surface area, exposed to the test solution in the chamber, to the crack size affects the anode/cathode area and can affect the corrosion potential in the crack. The area external to the crack should be significantly greater than the crack area.

<sup>8</sup> If crack growth rate information is to be obtained in addition to  $K_{IEAC}$ , side grooves may be desirable. Side grooves may promote straight fronted crack growth with some materials in some environments. Side groove depths with a total thickness reduction of 20% are suggested. Side groove root radii of less than 0.4 mm (0.016 in.) are suggested. Alternative methods to obtain crack growth rate information are available (see Test Method E 647) (1).

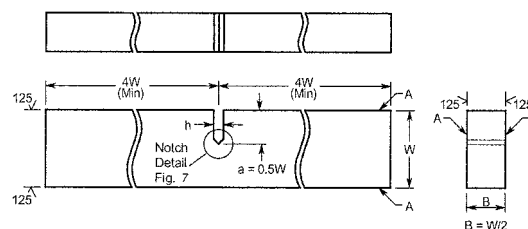

NOTE 1—A Surface Perpendicular and parallel within 0.001 W TIR

FIG. 4 Beam Specimen

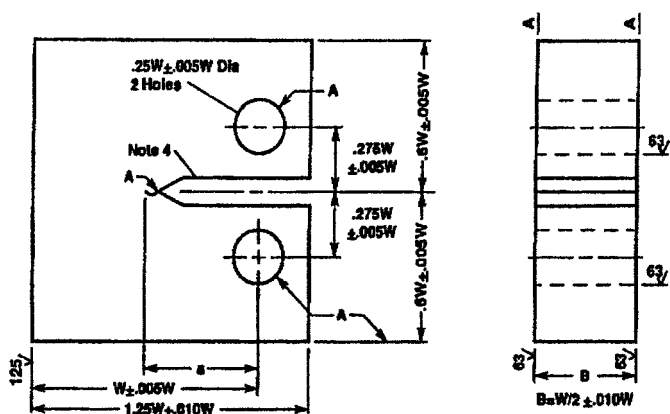

NOTE 1—A surface shall be perpendicular and parallel as applicable to within 0.002W TIR

NOTE 2—The intersection of the crack starter notch tips with the two specimen surfaces shall be equally distant from the top and bottom edges of the specimen within 0.005W

NOTE 3—Integral or attachable knife edges for clip gage attachment to the crack mouth may be used

NOTE 4—For starter notch and fatigue crack configuration see Fig. 7

FIG. 5 Standard Proportions and Tolerances for the Compact Specimen

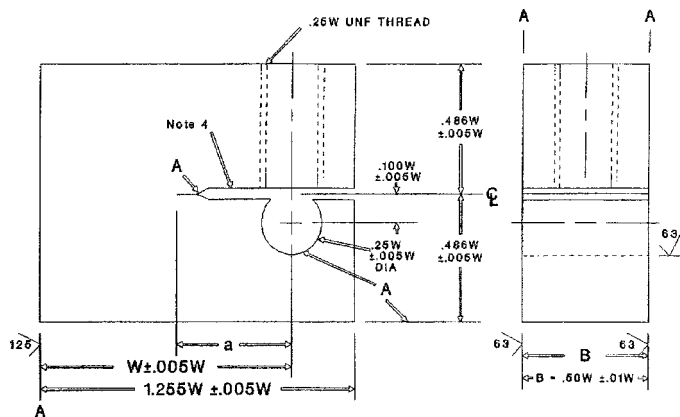

NOTE 1—A surfaces perpendicular and parallel as applicable to within 0.002W TIR.

NOTE 2—The intersection of the crack starter notch tips with the two specimen surfaces shall be equally distant from the top and bottom edges of the specimen within 0.005W.

NOTE 3—Integral or attachable knife edges for clip gage attachment to the crack mouth may be used.

NOTE 4—For starter notch and fatigue crack configuration see Fig. 7.

FIG. 6 Standard Configuration for the Modified Bolt-Load Compact Specimen; H/W = 0.486

include side grooves.<sup>8</sup> While for the determination of  $K_{IEAC}$ , it is recommended that  $W/B$  is 2:1, a 1:1 ratio can also be used, provided that  $B$ ,  $a$ , and  $W-a$  meet the validity criteria of 7.2.

7.1.4 Other specimen and loading configurations, for which well-established stress intensity calibrations are available, are acceptable as long as the specimen size requirements of 7.2 are met.

7.2 Specimen Size—For the results to be valid in accordance with this test method, it is required that the specimen be predominantly elastic in its behavior and that one or more of the following criteria be satisfied.

7.2.1 For the measurement of  $K_{IEAC}$ , it is required that  $B$ ,  $a_0$ , and  $W-a_0$  equal or exceed the quantity  $2.5 (K_{IEAC}/\sigma_{YS})^2$ , where  $\sigma_{YS}$  is the yield strength of the material determined at the temperature of the  $K_{IEAC}$  experiment.

7.2.2 For the measurement of  $K_{EAC}$ , it is required that  $W-a_0$  equal or exceed the quantity  $(4/\pi)(K_{EAC}/\sigma_{YS})^2$ . In this calculation,  $\sigma_{YS}$  may be replaced by  $\sigma_Y$  for high work hardening materials with an ultimate to yield strength ratio greater than 1.3. These requirements are consistent with those used in Test Method E 647.

7.2.3 For the beam and compact specimens, it is recommended that the crack length (total length of the machined notch plus the fatigue precrack) be between 0.45 and 0.55  $W$  whenever possible. However, normalized crack length values,  $a/W$ , may range from 0.25 to 0.75 in extreme instances, provided the requirements of 9.3 are met.

7.2.4 For the bolt-load compact specimen, applied  $K$  values continuously decrease with increasing crack length so that large crack lengths can be used. It is recommended that the total crack length (total length of the machined notch plus the fatigue precrack and the crack growth) be between 0.30 and .95  $W$ , provided the requirements of 8.8.2.5 are met.

7.3 Specimen Preparation:

7.3.1 The dimensional tolerances and surface finishes shown in Figs. 4-7 shall be followed in the specimen preparation.

7.3.2 Care should be taken in machining to prevent contamination of specimen and notch surfaces that are difficult or impossible to clean. An example of this is the copper deposit

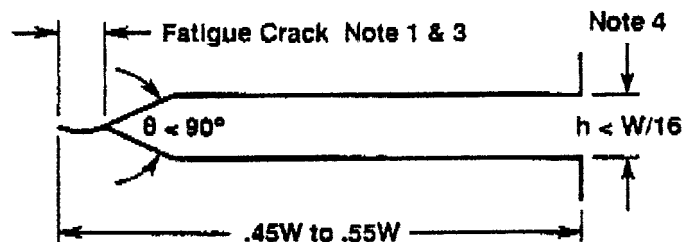

Straight Through Notch

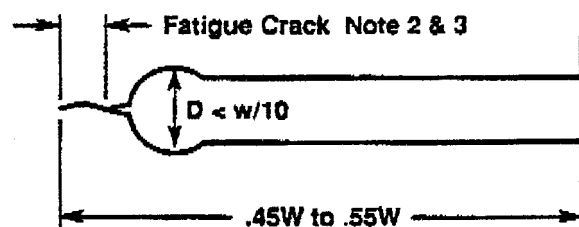

Slot Ending in Drilled Hole

NOTE 1—Fatigue crack extension on each surface of the specimen

NOTE 2—Fatigue crack extension on each surface of the specimen from the stress riser tipping the hole shall be at least 0.5  $D$  or 1.3 mm whichever is larger

NOTE 3—Crack starter notch shall be perpendicular to the specimen surface and to the intended direction of crack propagation within  $\pm 2^\circ$

NOTE 4—Notch width  $h$  need not be less than 1.6 mm

FIG. 7 Crack Starter Notch and Fatigue Crack Configurations

left by electric discharge machining (EDM) with a copper electrode.

7.3.3 Prior to fatigue precracking and testing, specimens should be cleaned in accordance with Practice G 1.

7.3.4 It is required that the specimen be fatigue precracked before testing. Fatigue precracking may be conducted in an ambient-air environment. The single-edge notched specimen may be fatigue precracked either in cantilever bending or in three-point bending. Fatigue precracking should be performed with the specimen fully heat treated to the condition in which it is to be tested.

7.3.4.1 The fatigue precrack shall extend to a depth of not less than  $0.10B$ , or 1.0 mm (0.04 in.), whichever is greater, beyond the tip of the machined notch as measured on each face of the specimen. It is required that the final 1 mm (0.04 in.) increment of fatigue precracking be conducted at a maximum stress intensity factor ( $K_{max}$ ) of not more than 60 % of the expected  $K_{EAC}$  value. The plane of the crack shall be parallel to both the specimen width and thickness directions within  $\pm 10^\circ$ .

7.3.4.2 Note that in some materials highly sensitive to stress corrosion cracking (such as ultrahigh-strength alloys),  $K_{EAC}$  values can be very low (less than  $20 \text{ MPa}\sqrt{\text{m}}$ ). Thus, permissible  $K_{max}$  levels for precracking highly sensitive materials might be restricted to small values. This restriction could dictate lengthy periods of fatigue precracking. Under these circumstances, it may be necessary to initiate fatigue precracking at  $K_{max}$  levels higher than 60 % of  $K_{EAC}$  and to follow a force-shedding ( $K$ -decreasing) program in fatigue cracking, as described in Test Method E 647. Force-shedding procedures provide an alternative means of achieving the final critical increment of precracking at adequately low  $K_{max}$  (no more than 60 % of  $K_{EAC}$ ).

7.3.5 Care should be taken to prevent the contamination of the crack after precracking and before testing.

## 8. General Procedure

8.1 *Number of Tests*—It is difficult to prescribe in advance the number of tests required to establish a valid  $K_{EAC}$  or  $K_{IEAC}$  value by this test method. The  $K_{EAC}$  or  $K_{IEAC}$  value is determined from several experiments at  $K$  levels in which specimens failed after a relatively long time under load or did not fail within a prescribed period (discussed in 8.4). For the beam and compact specimens to meet the force-bracketing requirements of 8.5, it is suggested that at least four  $K$  levels, and perhaps up to six, be investigated to ensure a measurement of  $K_{EAC}$  or  $K_{IEAC}$ . For the bolt-load compact specimen it is suggested that at least two and perhaps up to four specimens be tested to ensure a measurement of  $K_{EAC}$  or  $K_{IEAC}$ . As a general practice, it is recommended that test data be displayed graphically in terms of initial applied  $K$  ( $K$  based upon the applied force or displacement and  $a_0$ ) versus logarithmic time to failure. Guidance for the estimation of  $K_{EAC}$  or  $K_{IEAC}$  can be obtained for steels, aluminum alloys and titanium alloys (15-18). If neither past experience nor these references are helpful in making this estimate, a screening program with a limited number of specimens may be needed as a first phase in the testing program.

8.2 *Exposure to the Environment*—With some environment-material combinations, preconditioning of the specimen in the

environment prior to force or displacement application will greatly influence the resulting  $K_{EAC}$  or  $K_{IEAC}$  values. When this is the case, the specimen shall be exposed to the environment immediately preceding the test for at least 10 % of the total test time, or 8 h, whichever is less. The specimen shall then be loaded after this pre-exposure, either incrementally or continuously; however, the rate of force application should not exceed  $100 \text{ MPa}\sqrt{\text{m}} \text{ per min}$ .

8.3 *Displacement Changes*—Any significant change or interruption in loading, displacement, temperature, environmental exposure, or applied potential (if appropriate) needs to be evaluated and may invalidate the measurement of  $K_{EAC}$  or  $K_{IEAC}$ . Such interruptions need to be reported with the results. Occasional interruption of the force usually does not influence the results, but overloads of more than 5 % and repetitive force fluctuations of more than 1 % must be avoided and would invalidate the results.

8.4 *Test Duration*—A test will continue until one of the following occurs: (1) fracture, (2) evidence of subcritical crack growth is observed in the specimen, (3) a pre-established period of time has elapsed. Determining an adequate, but not excessive, test duration for threshold measurement is one of the most difficult aspects of  $K_{EAC}$  testing (5). The test duration that is adequate for a valid threshold measurement depends strongly on the material and the environment. For constant force tests involving ambient-temperature solutions of sodium chloride, including natural and ASTM substitute seawater (see Specification D 1141), the guideline test durations listed below are considered long enough to ensure that a valid threshold has been measured, but the actual times could be much shorter and need to be determined empirically. For constant displacement tests with relatively non-aggressive environments, the guideline test durations listed below may not be long enough to ensure that a valid threshold has been measured. The actual times could be longer and need to be determined empirically by using one or more trial samples. From this result, the test duration can be more accurately determined for the remainder of the tests. Use of techniques capable of detecting crack growth (acoustic emission) and of quantifying crack growth (d.c. potential drop) can be very helpful in establishing if a valid threshold has been reached.

steels ( $\sigma_S < 1,200 \text{ MPa}$ )	10 000 hours
steels ( $\sigma_S > 1,200 \text{ MPa}$ )	5 000 hours
aluminum alloys	10 000 hours
titanium alloys	1 000 hours

The large differences in guideline test durations among various alloys reflect inherent differences in incubation periods and in crack growth kinetics. In some instances, it may be impractical or impossible to achieve test durations as long as these. Under such circumstances, all data used in a  $K_{EAC}$  or  $K_{IEAC}$  determination should be qualified as to test duration (see 10.1.8). Adequate test durations could be much shorter in environments that are more aggressive than sodium chloride solutions, such as aqueous solutions of hydrogen sulfide, caustics, or ammonia.

8.5 *Force Bracketing*—The interval in applied  $K$  levels between specimens depends on the desired accuracy of the  $K_{EAC}$  or  $K_{IEAC}$  value and the number of specimens to be tested. The interval should be in the range from 10 % to 20 % of the

estimated  $K_{EAC}$  or  $K_{IEAC}$  value.

8.6 *Environmental Monitoring or Control*—Environmental parameters are of vital importance in  $K_{EAC}$  or  $K_{IEAC}$  testing; therefore, careful monitoring and control of the solution is required. Temperature, pH, conductivity, dissolved oxygen content, and electrode potential are variables that can affect environment-assisted cracking processes. Among these parameters, it is important to note that the electrode potential can exert a very strong influence on  $K_{EAC}$  or  $K_{IEAC}$ . It is especially important that this parameter be carefully monitored or controlled either continuously or at regular intervals throughout the test, or both. Every chamber opening, specimen inspection, and environment refreshing may result in a swing of the potential.

8.6.1 It is necessary to maintain enough solution in the environmental chamber to ensure that the crack-tip region of the specimen is immersed in the corrosive environment at all times and to ensure that the concentration of the electrolyte is not increased by evaporation. Long-term testing is conducive to the development of leaks at sites of contact between the environmental chamber and the specimen; thus, seals between the chamber and the specimen should be inspected regularly for leakage.

8.6.2 For tests involving sodium chloride solutions, replace the test solution at least weekly. It may be desirable to provide a circulation system to ensure a constant level of aeration of the bulk solution. The effects, if any, of aeration on  $K_{EAC}$  measurements are complex and not completely understood. Theoretical modeling studies have indicated, at least in steels, that the crack-tip region is completely deoxygenated regardless of the dissolved oxygen concentration in the bulk solution (19). In addition the  $CO_2$  from the air may play an important role. Laboratory studies on steels have supported this hypothesis by demonstrating a lack of response to changes in bulk solution dissolved oxygen content in  $K_{EAC}$  tests on a steel in a sodium chloride solution (20). However, this may not be the case for titanium alloys in which deaeration has been demonstrated to have an effect on  $K_{EAC}$  values. Also, note that aeration increases dissolved oxygen and, thus, may lower the pH, raise the corrosivity of the solution, and make the free corrosion potential more anodic. For some solutions, oxygen gradients along the crack length can establish potential gradients that assist ion migration into or out of the crack, thus, influencing the  $K_{EAC}$  measurement.

8.6.3 For tests in solutions other than sodium chloride, care should be taken to refresh the solution at regular intervals, if required, to maintain the desired environmental conditions. The frequency of refreshment required will depend on many variables and should be determined for the particular environment/test material combination being studied.

8.6.4 For tests that require polarizing the specimen to a potential other than the free corrosion potential (Reference Method G 5), several recommendations are offered. The use of a potentiostat is recommended rather than coupling the specimen to a dissimilar metal. However, when a potentiostat is used, appropriate care must be given to specimen grounding. For tests involving cathodic polarization with sacrificial anodes, periodic cleaning of the anodes and the specimen may be

necessary if significant corrosion or calcareous deposits are observed. It is further recommended that, when using sacrificial anodes, the surface area of the anode should be no less than 25 % of the specimen surface in contact with the solution. It is essential that the anodes be located so that the specimen is polarized uniformly throughout the test area. In this regard, adequate spacing between the specimen and anodes is necessary. Cathodic or anodic polarization of the sample may promote changes in the solution chemistry particularly the solution pH. As a result, when polarizing currents are applied, the pH should be checked more frequently and precautions not required for open circuit potential experiment should be considered.

8.6.5 For bolt-load compact tests, remove the force at the end of the test while measuring the CMOD. The change in CMOD upon unloading may be less than that of the original bolt-loading of the specimen because of the presence of corrosion products on the crack surfaces or force relaxation. If the change in CMOD upon unloading is less than 90 % of that of the loading, check for presence of corrosion products and for evidence of force relaxation (see 5.1.7). If no reason can be found for a change in CMOD due to unloading that is less than 90 % of that due to loading, then the constant displacement test method may not be suitable for these test conditions, and a constant force test should be considered.

8.7 *Post-Test Examination*—Specimen fracture surfaces must be visually examined after testing. The fracture surfaces of specimens that did not fail shall be examined for evidence of environment-assisted crack growth. Evidence of crack growth is taken as proof that the specimen was loaded at a  $K$  level higher than  $K_{EAC}$  or  $K_{IEAC}$ .

8.7.1 Break the specimen to expose the crack, taking care to minimize deformation. Cooling ferritic steel specimens enough to ensure brittle behavior may be helpful. Advancing the crack by fatigue may be needed in more ductile materials.

8.7.2 Inspect the tip of the initial fatigue precrack, looking for evidence of crack extension. Characterize the fracture surface of the crack extension in comparison with the fracture surface formed by breaking the specimen to expose the crack. This inspection must be made with an instrument capable of resolving 0.025 mm (0.001 in.). A scanning electron microscope is useful for the fracture surface inspection and characterization.

8.8 *Specimen Measurement*—Specimen dimensions shall conform to the dimensions and tolerances shown in Figs. 4-6. Three fundamental measurements are necessary to calculate  $K$ , namely: thickness,  $B$ ; original crack size,  $a_o$ ; and width,  $W$ . If significant metal loss is expected during the experiment, dimensions  $B$  and  $W$  must be measured prior to testing.

8.8.1 Measure the thickness,  $B$ , to the nearest 0.025 mm (0.001 in.) or to 0.1 %, whichever is larger, at no fewer than three equally spaced positions along the line of expected crack extension from the fatigue crack tip to the unnotched side of the specimen. Record the average of the three measurements as  $B$ .

8.8.2 After fracture measure the original crack size,  $a_o$ , to the nearest 0.5 % at the following three positions: at the center of the crack front, midway between the center of the crack



front, and the ends of the crack front on each side surface. Calculate the average of the three measurements, and use the resulting crack length to calculate  $K$ . The following requirements apply to the fatigue crack front:

8.8.2.1 The difference between any two of the three crack length measurements shall not exceed 10 % of the average.

8.8.2.2 No part of the crack front shall be closer to the machined starter notch than 0.10  $B$  or 1 mm (0.04 in.) minimum.

8.8.2.3 The surface crack length measurements shall not differ from the average crack length by more than 15 %.

8.8.2.4 The difference between these two surface measurements shall not exceed 10 % of the average crack length.

8.8.2.5 For the bolt-load compact specimen the surface remaining ligament measurements (that is,  $W - a$ ) shall not differ from the average remaining ligament measurement by more than 15 %.

8.8.3 Measure the width,  $W$ , using the designations in Figs. 4-6 appropriate to the specific specimen geometry.

8.8.4 The plane of the original crack shall be parallel to both the specimen width and thickness directions within  $\pm 10^\circ$ .

## 9. Calculations or Interpretation of Results

### 9.1 Determining the Stress Intensity Factor, $K$ :

9.1.1 The formula for the beam specimen (21) is:

$$K_I = \frac{M}{B(W)^2} f(a_o/W) \quad (2)$$

where:

$$f(a_o/W) = \frac{6(a_o/W)^{1/2}}{\alpha^{3/2}} \{1.9878 - 1.3253 (a_o/W) + (\alpha) (a_o/W) [-3.8308 + 10.1081 (a_o/W) - 17.9415 (a_o/W)^2 + 16.8282 (a_o/W)^3 - 6.2241 (a_o/W)^4]\}$$

- $\alpha$  =  $1 - (a_o/W)$ ,
- $M$  = bending moment on the crack plane,
- $M$  =  $W_a L_a + W_t L$ ,
- $W_a$  = weight of arm,
- $L_a$  = distance from notch plane to center of gravity of arm,
- $W_t$  = total weight of platen, platen support, and added weight,
- $L$  = moment arm as shown in Fig. 1,
- $B$  = specimen thickness<sup>9</sup> as determined in 8.8.1,
- $W$  = specimen width as determined in 8.8.3, and
- $a_o$  = original crack size as determined in 8.8.2.

This expression for  $K$  is valid for  $0 < a/W < 1$ .

9.1.2 The stress intensity factor formula for the compact specimen, taken from Test Method E 399, is:

$$K = \left[ \frac{P}{BW^2} \right] f\left(\frac{a_o}{W}\right) \quad (3)$$

where:

$$f\left(\frac{a_o}{W}\right) = \frac{\left(2 + \frac{a_o}{W}\right)}{\left(1 - \frac{a_o}{W}\right)^2} \left[ 0.886 + 4.64 \left(\frac{a_o}{W}\right) - 13.32 \left(\frac{a_o}{W}\right)^2 + 14.72 \left(\frac{a_o}{W}\right)^3 - 5.6 \left(\frac{a_o}{W}\right)^4 \right]$$

- $a_o$  = original crack size as determined in 8.8.2,
- $B$  = specimen thickness<sup>9</sup> as determined in 8.8.1,
- $W$  = specimen width as determined in 8.8.3, and
- $P$  = force.

This expression for  $K$  is valid for  $a/W$  from 0.2 to 1.

9.1.3 The stress intensity factor formula for the bolt-load compact specimen (22) is:

$$K_I = [V_m E/W^{1/2}] f(a/w) \quad (4)$$

$$f(a/W) = [1 - a/W]^{1/2} [0.654 - 1.88 (a/W) + 2.66 (a/W)^2 - 1.233 (a/W)^3]$$

where:

- $V_m$  = crack-mouth opening displacement on the specimen face as determined in 6.3,
- $E$  = Young's modulus,
- $a$  = original or final crack size as determined in 8.8.2 and 8.8.4,
- $B$  = specimen thickness<sup>9</sup> as determined in 8.8.1, and
- $W$  = specimen width as determined in 8.8.3.

This expression for  $K$  is valid for  $H/W = 0.486$  and for  $a/W$  from 0.3 to 1.

### 9.2 Determining $K_{EAC}$ or $K_{IEAC}$ :

9.2.1 For the beam and compact specimens the value of  $K_{EAC}$  or  $K_{IEAC}$  determined by this test method is the highest applied  $K$  level that did not cause a fracture or evidence of subcritical crack growth in a specimen after reaching the recommended test duration (determined by the procedure described in 8.7).

9.2.2 For the bolt-load compact specimen, the value of  $K_{EAC}$  or  $K_{IEAC}$  determined by this test method is the lowest applied  $K$  level that shows evidence of subcritical crack growth in a specimen after reaching the recommended test duration (determined by the procedure described in 8.7).

### 9.3 Validity Check:

9.3.1 Calculate the value of the parameter  $2.5 (K_{IEAC}/\sigma_{YS})^2$ , where  $\sigma_{YS}$  is the 0.2 % offset tensile yield strength at the same temperature as the threshold  $K$  test (see Methods E 8). This quantity must be less than each of  $B$ ,  $a_o$ , and  $W - a_o$  to meet the primary plane strain validity criteria for  $K_{IEAC}$ .

9.3.2 Calculate the value of the parameter  $(4/\pi)(K_{EAC}/\sigma_{YS})^2$ ; (in this calculation,  $\sigma_{YS}$  may be replaced by  $\sigma_Y$  for high work-hardening materials with an ultimate to yield strength ratio greater than 1.3. This quantity must be less than  $(W - a_o)$  to meet the validity criteria for  $K_{EAC}$ .

## 10. Report

10.1 The report shall include the following information for each specimen tested.

10.1.1 The type of specimen tested and its principal dimensions of the specimen, including thickness, width, notch depth, precrack length, crack plane orientation as defined in Test Method E 399, and, if present, dimensions of side-groove.

<sup>9</sup> For side grooved specimens replace  $B$  with  $B_{effective}$  where  $B_{effective} = \sqrt{BB_N}$  and  $B_N$  is the net thickness.

10.1.2 Descriptions of the test equipment, including loading fixture, method of loading, rate of initial loading, displacement gages, environmental chamber, and all equipment used for environmental monitoring and control.

10.1.3 Description of the tested material, including available chemical analyses, processing, and mechanical property data, including 0.2 % offset yield strength and tensile strength.

10.1.4 Details of the fatigue precracking procedure, including the value of  $K_{max}$  and the stress intensity range,  $\Delta K$  used in the final increment precracking (defined in 7.3.4).

10.1.5 Composition of the bulk solution, time in solution before loading, temperature, and frequency of the replacement of the bulk solution throughout the duration of the test.

10.1.6 Results of monitoring or control of environmental variables, including specimen potential and temperature, pH, and dissolved oxygen content of the bulk solution. Such variables must be reported in terms of both the normal daily range experienced throughout the duration of the test and relevant trends.

10.1.7 Fracture appearance, including fatigue crack irregularity, out-of-plane cracking, crack branching, shear lips, and evidence of subcritical crack growth in specimens.

10.1.8  $K_{IEAC}$  and  $K_{EAC}$  qualified relative to the following:

10.1.8.1  $K_I$  and time-to-failure values bracketed in the determination of threshold.

10.1.8.2 Number of replicate tests included in the bracketing.

10.1.8.3 Duration of all tests that did not result in failure (run outs).

10.1.8.4 The  $a/W$  values of the specimens used in threshold determination.

10.1.8.5 Whether the validity criteria for specimen dimensions were met in each instance.

10.1.9 Anomalies, interruptions, or transients encountered during the test must be described in terms to magnitude, time of occurrence, and duration.

## 11. Precision and Bias

11.1 *Precision*—The precision of  $K_{EAC}$  or  $K_{IEAC}$  determinations is a function of the precision of the several specimen dimensions and test stand measurements, the precision of the force measurement, and the precision of the post-test measurement of crack length. In addition, significant variations in the  $K_{EAC}$  or  $K_{IEAC}$  value can result if the active environmental

parameters are not adequately controlled and if the tested material is not homogeneous. It is not possible to assess the precision of the test in the face of so many variables. However, it is possible to derive useful information concerning the precision of a  $K_{EAC}$  or  $K_{IEAC}$  measurement from the results of two interlaboratory test programs (1, 23). In these programs, it was attempted to choose a homogeneous test material and the test environment was chosen as one that was easy to achieve.

11.1.1 Wei and Novak report results of an interlaboratory test program conducted by an ASTM Joint Task Group E24.04.02/G01.06.04 (1). The program involved testing precracked cantilever-beam specimens of AISI 4340 steel, heat treated to a yield strength of 1240 MPa in 3.5 % NaCl aqueous solution at room temperature and at the freely corroding potential. Based on results provided by eight laboratories, the apparent  $K_{IEAC}$  after 1000 h of testing was determined to have a mean value of 34.5 MPa $\sqrt{m}$  with an estimated 95 % confidence interval of 5.8 MPa $\sqrt{m}$ . One of the participating laboratories extended the testing time to 20 000 h and measured a  $K_{IEAC}$  value of 30 MPa $\sqrt{m}$ . This value is consistent with those measured in the 4000 h experiments.

11.1.2 Yokobori et al report results of an interlaboratory test program conducted by the 129th Committee of the Japan Society for the Promotion of Science (23). The test program was quite similar to Ref (22) with regard to specimens, materials, and environment, except that longer tests were conducted. In one test material, based on results provided by five laboratories, the apparent  $K_{IEAC}$  after 4000 h of testing was determined to have a mean value of 44.3 MPa $\sqrt{m}$  with a standard deviation of 4.33 MPa $\sqrt{m}$ . In a second test material, based upon 4000-h tests conducted by six laboratories, the apparent  $K_{IEAC}$  had a mean value of 28.9 MPa $\sqrt{m}$  with a standard deviation of 5.52 MPa $\sqrt{m}$ .

11.1.3 Variations similar to those reported in Refs (1, 23) should be expected from future experiments.

11.2 *Bias*—There is no accepted standard value of  $K_{IEAC}$  for any material. In the absence of a fundamental value, no meaningful statement can be made concerning the bias of data.

## 12. Keywords

12.1 aqueous aggressive environment; constant-force test; elastic stress; environment-assisted cracking; metallic materials; threshold stress intensity factor

## REFERENCES

- (1) Wei, R.P., and Novak, S.R., "Interlaboratory Evaluation of  $K_{ISCC}$  and da/dt Measurement Procedures for High-Strength Steels," *Journal of Testing and Evaluation*, Vol 15, 1987, pp. 38-75.
- (2) Gangloff, R.P., and Ives, M.B., eds., "Environment-Induced Cracking of Metals," NACE, Houston, Texas, 1990.
- (3) Brown, B.F., "A New Stress-Corrosion Test for High-Strength Alloys," *Materials Research & Standards*, Vol 6, No. 3, March 1966, pp. 129-133.
- (4) Brown, B.F., "On the Existence of a Threshold Stress for Corrosion Cracking in Titanium Alloys in Salt Water," *Journal of Materials*, JMLSA, Vol 5, No. 4, December 1970, pp. 786-791.
- (5) Oriani, R.A., and Josephic, P.H., "Equilibrium Aspects of Hydrogen Induced Cracking of Steels," *Acta Metallurgica*, Vol 22, 1974, pp. 1065-1074.
- (6) *Characterization of Environmentally Assisted Cracking for Design: State of the Art*, NMAP-386, National Materials Advisory Board, National Academy Press, Washington, D.C., 1982.
- (7) Fessler, R.R., and Barlo, T.J., "Threshold-Stress Determination Using Tapered Specimens and Cyclic Stresses," ASTM STP 821, 1984, pp. 368-382.
- (8) Crooker, T.W., Hauser, J.A. II, and Bayles, R.A., "Ripple-Loading Effects on Stress-Corrosion Cracking in Steels," *Proceedings of the Third International Conference on Environmental Degradation of Engineering Materials*, The Pennsylvania State University, April 13-15, 1987, pp. 521-532.
- (9) Fujii, C.T., "Effect of Specimen Dimensions on  $K_{ISCC}$  Determination by the Cantilever Method," NRL Report 8236, Naval Research Laboratory, Washington, D.C., May 31, 1978.
- (10) Kobayashi, J-I., and Takeshi, Y., "Evaluation of Resistance of Steel Plate to Sulfide Stress Cracking in Sour West Service," *Predictive Capabilities in Environmentally Assisted Cracking*, PVP-Vol 99, American Society of Mechanical Engineers, 1985, pp. 223-234.
- (11) Piper, D.E., Smith, S.H., and Carter, R.V., "Corrosion Fatigue and Stress-Corrosion Cracking in Aqueous Environments," *Metals Engineering Quarterly*, Vol 8, No. 3, 1968, pp. 50-63.
- (12) Ciaraldi, S.W., "Application of a Double Cantilever Beam Specimen to Stress-Corrosion Evaluation of High-Alloy Production Tubulars," *Corrosion* 83, Paper No. 162, NACE, Houston, Texas, 1983.
- (13) Ritter, J.C., "Modified Thickness Criterion for Fracture Toughness Testing," *Engineering Fracture Mechanics*, Vol 9, 1977, pp. 529-540.
- (14) Novak, S.R., "Effect of Prior Uniform Plastic Strain on the  $K_{ISCC}$  of High Strength Steels in Sea Water," *Engineering Fracture Mechanics*, Vol 5, 1973, pp. 727-763.
- (15) Gangloff, R. P., "A Review and Analysis of the Threshold for Hydrogen Environment Embrittlement of Steels," *Corrosion Prevention and Control*, 33rd Sagamore Army Materials Research Conference, M. Levy and S Isserow, eds., U. S. Army Laboratory Command, Watertown, MA, 1986, pp 64-111.
- (16) Hertzberg, R. W., *Deformation and Fracture Mechanics of Engineering Materials*, Ch. 11, 2nd Ed., John Wiley and Sons, New York, NY (1983).
- (17) *Atlas of Stress-Corrosion and Corrosion Fatigue Curves*, A. J. McEvily, ed., ASM International, Metals Park, Oh, 1990.
- (18) Crykklis, W. F., *Environment-Sensitive Fracture on Engineering Materials*, Z. A. Forpici, ed., TMS-AIME, Warrendale, PA, 1979, pp. 303-313.
- (19) Gangloff, R.P., and Turnbull, A., "Crack Electrochemistry Modeling and Fracture Mechanics Measurement of the Hydrogen Embrittlement Threshold in Steel," *Modeling Environmental Effects on Crack Initiation and Propagation*, TMS-AIME, Warrendale, Pa., 1986, pp. 55-81.
- (20) Judy, R.W., Jr., King, W.E., Jr., Hauser, J.A., II, and Crooker, T.W., "Influence of Experimental Variables on da/dt and  $K_{ISCC}$  Measurement in High-Strength Steels," *ASTM STP 1049*, 1990, pp. 410-422.
- (21) Baratta, F. I., "Stress-Intensity Factor Solution for Cantilever Loaded-Beam Specimen," 1992 letter, on file at ASTM.
- (22) Underwood, J.H., Olmstead, V.J., Askew, J.C., Kapusta, A.A., and Young, G.A., "Environmentally Controlled Fracture of an Overstrained A723 Steel Thick-Wall Cylinder," *ASTM STP 1189*, 1993, pp. 443-460.
- (23) Tokobori, T., Watanabe, J., and Iwadate, T., "Evaluation of the  $K_{ISCC}$  Testing Procedure by Round Robin Tests on Steels" *ASTM STP 945*, 1985, pp. 843-866.

*The American Society for Testing and Materials takes no position respecting the validity of any patent rights asserted in connection with any item mentioned in this standard. Users of this standard are expressly advised that determination of the validity of any such patent rights, and the risk of infringement of such rights, are entirely their own responsibility.*

*This standard is subject to revision at any time by the responsible technical committee and must be reviewed every five years and if not revised, either reapproved or withdrawn. Your comments are invited either for revision of this standard or for additional standards and should be addressed to ASTM Headquarters. Your comments will receive careful consideration at a meeting of the responsible technical committee, which you may attend. If you feel that your comments have not received a fair hearing you should make your views known to the ASTM Committee on Standards, at the address shown below.*

*This standard is copyrighted by ASTM, 100 Barr Harbor Drive, PO Box C700, West Conshohocken, PA 19428-2959, United States. Individual reprints (single or multiple copies) of this standard may be obtained by contacting ASTM at the above address or at 610-832-9585 (phone), 610-832-9555 (fax), or service@astm.org (e-mail); or through the ASTM website (www.astm.org).*