



Standard Test Method for Dynamic Young's Modulus, Shear Modulus, and Poisson's Ratio by Impulse Excitation of Vibration¹

This standard is issued under the fixed designation E 1876; the number immediately following the designation indicates the year of original adoption or, in the case of revision, the year of last revision. A number in parentheses indicates the year of last reappraisal. A superscript epsilon (ϵ) indicates an editorial change since the last revision or reappraisal.

1. Scope

1.1 This test method covers determination of the dynamic elastic properties of elastic materials at ambient temperatures. Specimens of these materials possess specific mechanical resonant frequencies that are determined by the elastic modulus, mass, and geometry of the test specimen. The dynamic elastic properties of a material can therefore be computed if the geometry, mass, and mechanical resonant frequencies of a suitable (rectangular or cylindrical geometry) test specimen of that material can be measured. Dynamic Young's modulus is determined using the resonant frequency in either the flexural or longitudinal mode of vibration. The dynamic shear modulus, or modulus of rigidity, is found using torsional resonant vibrations. Dynamic Young's modulus and dynamic shear modulus are used to compute Poisson's ratio.

1.2 Although not specifically described herein, this test method can also be performed at cryogenic and high temperatures with suitable equipment modifications and appropriate modifications to the calculations to compensate for thermal expansion.

1.3 There are material specific ASTM standards that cover the determination of resonance frequencies and elastic properties of specific materials by sonic resonance or by impulse excitation of vibration. Test Methods C 215, C 623, C 747, C 848, C 1198, and C 1259 may differ from this test method in several areas (for example; sample size, dimensional tolerances, sample preparation). The testing of these materials shall be done in compliance with these material specific standards. Where possible, the procedures, sample specifications and calculations are consistent with these test methods.

1.4 The values stated in SI units are to be regarded as the standard.

1.5 *This standard does not purport to address all of the safety concerns, if any, associated with its use. It is the responsibility of the user of this standard to establish appropriate safety and health practices and determine the applicability of regulatory limitations prior to use.*

2. Referenced Documents

2.1 ASTM Standards:

- C 215 Test Method for Fundamental Transverse, Longitudinal, and Torsional Frequencies of Concrete Specimens²
- C 372 Test Method for Linear Thermal Expansion of Porcelain Enamel and Glaze Frits and Fired Ceramic Whiteware Products by the Dilatometer Method³
- C 623 Test Method for Young's Modulus, Shear Modulus, and Poisson's Ratio for Glass and Glass-Ceramics by Resonance³
- C 747 Test Method for Moduli of Elasticity and Fundamental Frequencies of Carbon and Graphite Materials by Sonic Resonance⁴
- C 848 Test Method for Young's Modulus, Shear Modulus, and Poisson's Ratio for Ceramic Whitewares by Resonance³
- C 1161 Test Method for Flexural Strength of Advanced Ceramics at Ambient Temperature⁴
- C 1198 Test Method for Dynamic Young's Modulus, Shear Modulus, and Poisson's Ratio for Advanced Ceramics by Sonic Resonance⁴
- C 1259 Test Method for Young's Modulus, Shear Modulus and Poisson's Ratio for Advanced Ceramics by Impulse Excitation of Vibration⁴
- E 6 Terminology Relating to Methods of Mechanical Testing⁵
- E 177 Practice for Use of the Terms Precision and Bias in ASTM Test Methods⁶

3. Terminology

3.1 *Definitions*—The definitions of terms relating to mechanical testing appearing in Terminology E 6 should be considered as applying to the terms used in this test method.

3.1.1 *dynamic mechanical measurement, n*—a technique in which either the modulus or damping, or both, of a substance under oscillatory applied force or displacement is measured as a function of temperature, frequency, or time, or combination thereof.

¹ This test method is under the jurisdiction of ASTM Committee E28 on Mechanical Testing and is the direct responsibility of Subcommittee E28.03 on Elastic Properties.

Current edition approved Dec. 10, 2000. Published February 2001. Last previous edition E 1876-97.

² *Annual Book of ASTM Standards*, Vol 04.02.

³ *Annual Book of ASTM Standards*, Vol 15.02.

⁴ *Annual Book of ASTM Standards*, Vol 15.01.

⁵ *Annual Book of ASTM Standards*, Vol 03.01.

⁶ *Annual Book of ASTM Standards*, Vol 14.02.

3.1.2 *elastic limit* [FL⁻²], *n*—the greatest stress that a material is capable of sustaining without permanent strain remaining upon complete release of the stress. **E 6**

3.1.3 *elastic modulus* [FL⁻²], *n*—the ratio of stress to strain below the proportional limit. **E 6**

3.1.4 *Poisson's ratio* (μ) [nd], *n*—the absolute value of the ratio of transverse strain to the corresponding axial strain resulting from uniformly distributed axial stress below the proportional limit of the material.

3.1.4.1 *Discussion*—In isotropic materials, Young's Modulus (E), shear modulus (G), and Poisson's ratio (μ) are related by the following equation:

$$\mu = (E/2G) - 1 \quad (1)$$

3.1.5 *proportional limit* [FL⁻²], *n*—the greatest stress that a material is capable of sustaining without deviation from proportionality of stress to strain (Hooke's law). **E 6**

3.1.6 *shear modulus* (G) [FL⁻²], *n*—the elastic modulus in shear or torsion. Also called modulus of rigidity or torsional modulus. **E 6**

3.1.7 *Young's modulus* (E) [FL⁻²], *n*—the elastic modulus in tension or compression. **E 6**

3.2 Definitions of Terms Specific to This Standard:

3.2.1 *antinodes*, *n*—two or more locations that have local maximum displacements, called antinodes, in an unconstrained slender rod or bar in resonance. For the fundamental flexure resonance, the antinodes are located at the two ends and the center of the specimen.

3.2.2 *elastic, adj*—the property of a material such that an application of stress within the elastic limit of that material making up the body being stressed will cause an instantaneous and uniform deformation, which will be eliminated upon removal of the stress, with the body returning instantly to its original size and shape without energy loss. Most elastic materials conform to this definition well enough to make this resonance test valid.

3.2.3 *flexural vibrations*, *n*—the vibrations that occur when the oscillations in a slender rod or bar are in a plane normal to the length dimension.

3.2.4 *homogeneous, adj*—the condition of a specimen such that the composition and density are uniform, so that any smaller specimen taken from the original is representative of the whole. Practically, as long as the geometrical dimensions of the test specimen are large with respect to the size of individual grains, crystals, components, pores, or microcracks, the body can be considered homogeneous.

3.2.5 *in-plane flexure*, *n*—for rectangular parallelepiped geometries, a flexure mode in which the direction of displacement is in the major plane of the test specimen.

3.2.6 *isotropic, adj*—the condition of a specimen such that the values of the elastic properties are the same in all directions in the material. Materials are considered isotropic on a macroscopic scale, if they are homogeneous and there is a random distribution and orientation of phases, crystallites, components, pores, or microcracks.

3.2.7 *nodes*, *n*—a slender rod or bar in resonance containing one or more locations having a constant zero displacement. For the fundamental flexural resonance of such a rod or bar, the

nodes are located at 0.224 L from each end, where L is the length of the specimen.

3.2.8 *out-of-plane flexure*, *n*—for rectangular parallelepiped geometries, a flexure mode in which the direction of displacement is perpendicular to the major plane of the test specimen.

3.2.9 *resonant frequency*, *n*—naturally occurring frequencies of a body driven into flexural, torsional, or longitudinal vibration that are determined by the elastic modulus, mass, and dimensions of the body. The lowest resonant frequency in a given vibrational mode is the fundamental resonant frequency of that mode.

3.2.10 *slender rod or bar*, *n*—in dynamic elastic property testing, a specimen whose ratio of length to minimum cross-sectional dimension is at least 5 and preferably in the range from 20 to 25.

3.2.11 *torsional vibrations*, *n*—the vibrations that occur when the oscillations in each cross-sectional plane of a slender rod or bar are such that the plane twists around the length dimension axis.

3.2.12 *longitudinal vibrations*, *n*—the vibrations that occur when the oscillations in a slender rod or bar are parallel to the length of the rod or bar.

4. Summary of Test Method

4.1 This test method measures the fundamental resonant frequency of test specimens of suitable geometry by exciting them mechanically by a singular elastic strike with an impulse tool. A transducer (for example, contact accelerometer or non-contacting microphone) senses the resulting mechanical vibrations of the specimen and transforms them into electric signals. Specimen supports, impulse locations, and signal pick-up points are selected to induce and measure specific modes of the transient vibrations. The signals are analyzed, and the fundamental resonant frequency is isolated and measured by the signal analyzer, which provides a numerical reading that is (or is proportional to) either the frequency or the period of the specimen vibration. The appropriate fundamental resonant frequencies, dimensions, and mass of the specimen are used to calculate dynamic Young's modulus, dynamic shear modulus, and Poisson's ratio.

5. Significance and Use

5.1 This test method may be used for material development, characterization, design data generation, and quality control purposes.

5.2 This test method is specifically appropriate for determining the modulus of materials that are elastic, homogeneous, and isotropic (1).⁷

5.3 This test method addresses the room temperature determination of dynamic moduli of elasticity of slender bars (rectangular cross section) and rods (cylindrical). Flat plates and disks may also be measured similarly, but the required equations for determining the moduli are not addressed herein.

5.4 This dynamic test method has several advantages and differences from static loading techniques and from resonant techniques requiring continuous excitation.

⁷ The boldface numbers in parentheses refer to the list of references at the end of this standard.

5.4.1 The test method is nondestructive in nature and can be used for specimens prepared for other tests. The specimens are subjected to minute strains; hence, the moduli are measured at or near the origin of the stress-strain curve, with the minimum possibility of fracture.

5.4.2 The impulse excitation test uses an impact tool and simple supports for the test specimen. There is no requirement for complex support systems that require elaborate setup or alignment.

5.5 This technique can be used to measure resonant frequencies alone for the purposes of quality control and acceptance of test specimens of both regular and complex shapes. A range of acceptable resonant frequencies is determined for a specimen with a particular geometry and mass. The technique is particularly suitable for testing specimens with complex geometries (other than parallelepipeds, cylinders/rods, or disks) that would not be suitable for testing by other procedures. Any specimen with a frequency response falling outside the prescribed frequency range is rejected. The actual modulus of each specimen need not be determined as long as the limits of the selected frequency range are known to include the resonant frequency that the specimen must possess if its geometry and mass are within specified tolerances.

5.6 If a thermal treatment or an environmental exposure affects the elastic response of the test specimen, this test method may be suitable for the determination of specific effects of thermal history, environment exposure, and so forth. Specimen descriptions should include any specific thermal treatments or environmental exposures that the specimens have received.

6. Interferences

6.1 The relationships between resonant frequency and dynamic modulus presented herein are specifically applicable to homogeneous, elastic, isotropic materials.

6.1.1 This method of determining the moduli is applicable to composite and inhomogeneous materials only with careful consideration of the effect of inhomogeneities and anisotropy. The character (volume fraction, size, morphology, distribution, orientation, elastic properties, and interfacial bonding) of the reinforcement and inhomogeneities in the specimens will have a direct effect on the elastic properties of the specimen as a whole. These effects must be considered in interpreting the test results for composites and inhomogeneous materials.

6.1.2 The procedure involves measuring transient elastic vibrations. Materials with very high damping capacity may be difficult to measure with this technique if the vibration damps out before the frequency counter can measure the signal (commonly within three to five cycles).

6.1.3 If specific surface treatments (coatings, machining, grinding, etching, and so forth) change the elastic properties of the near-surface material, there will be accentuated effects on the properties measured by this flexural method, as compared to static/bulk measurements by tensile or compression testing.

6.1.4 This test method is not satisfactory for specimens that have major discontinuities, such as large cracks (internal or surface) or voids.

6.2 This test method for determining moduli is limited to specimens with regular geometries (rectangular parallelepiped,

cylinders, and disks) for which analytical equations are available to relate geometry, mass, and modulus to the resonant vibration frequencies. This test method is not appropriate for determining the elastic properties of materials that cannot be fabricated into such geometries.

6.2.1 The analytical equations assume parallel and concentric dimensions for the regular geometries of the specimen. Deviations from the specified tolerances for the dimensions of the specimens will change the resonant frequencies and introduce error into the calculations.

6.2.2 Edge treatments such as chamfers or radii are not considered in the analytical equations. Edge chamfers change the resonant frequency of the test bars and introduce error into the calculations of the dynamic modulus. It is recommended that specimens for this test method not have chamfered or rounded edges.

6.2.3 For specimens with as-fabricated and rough or uneven surfaces, variations in dimension can have a significant effect in the calculations. For example, in the calculation of dynamic modulus, the modulus value is inversely proportional to the cube of the thickness. Uniform specimen dimensions and precise measurements are essential for accurate results.

6.3 This test method assumes that the specimen is vibrating freely, with no significant restraint or impediment. Specimen supports should be designed and located properly in accordance with the instructions so the specimen can vibrate freely in the desired mode. In using direct contact transducers, the transducer should be positioned away from antinodes and with minimal force to avoid interference with free vibration.

6.4 Proper location to the impulse point and transducer is important in introducing and measuring the desired vibration mode. The locations of the impulse point and transducer should not be changed in multiple readings; changes in position may develop and detect alternate vibration modes. In the same manner, the force used in impacting should be consistent in multiple readings.

6.5 If the frequency readings are not repeatable for a specific set of impulse and transducer locations on a specimen, it may be because several different modes of vibration are being developed and detected in the test. The geometry of the test bar and desired vibration mode should be evaluated and used to identify the nodes and antinodes of the desired vibrations. More consistent measurements may be obtained if the impulse point and transducer locations are shifted to induce and measure the single desired mode of vibration.

7. Apparatus

7.1 Apparatus suitable for accurately detecting, analyzing, and measuring the fundamental resonant frequency or period of a vibrating free-free beam is used. The test apparatus is shown in Fig. 1. It consists of an impulser, a suitable pickup transducer to convert the mechanical vibration into an electrical signal, an electronic system (consisting of a signal conditioner/amplifier, a signal analyzer, and a frequency read-out device), and a support system. Commercial instrumentation

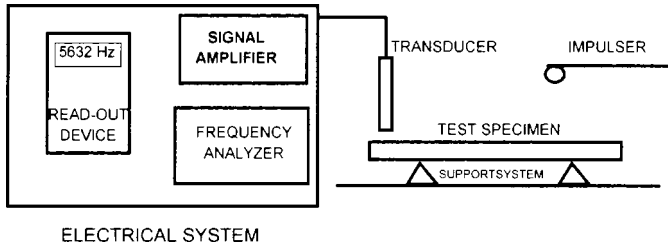

FIG. 1 Block Diagram of Typical Test Apparatus

is available that measures the frequency or period of the vibrating specimen.⁸

7.2 Impulser—The exciting impulse is imparted by lightly striking the specimen with a suitable implement. This implement should have most of its mass concentrated at the point of impact and have mass sufficient to induce a measurable mechanical vibration, but not so large as to displace or damage the specimen physically. In practice, the size and geometry of the impulser depends on the size and weight of the specimen and the force needed to produce vibration. For commonly tested geometries (small bars, rods, and disks) an example of such an impulser would be a steel sphere 0.5 cm in diameter glued to the end of a flexible 10-cm long polymer rod. (See Fig. 2.) An alternate impulser would be a solid metal, ceramic, or polymer sphere (0.1 to 1.0 cm in diameter) dropped on the specimen through a guide tube to ensure proper impulse position.

7.3 Signal Pickup—Signal detection can be by means of transducers in direct contact with the specimen or by noncontact transducers. Contact transducers are commonly accelerometers using piezoelectric or strain gage methods to measure the vibration. Non contact transducers are commonly acoustic microphones, but they may also use laser, magnetic, or capacitance methods to measure the vibration. The frequency range of the transducer shall be sufficient to measure the expected frequencies of the specimens of interest. A suitable

⁸ Suitable instrumentation is the Grindosonic instrument. The sole source of supply of this instrument is J. W. Lemmens, 3466 Bridgeland Dr., St. Louis, MO 63044-2606. If you are aware of alternative suppliers, please provide this information to ASTM Headquarters. Your comments will receive careful consideration at a meeting of the responsible technical committee¹, which you may attend.

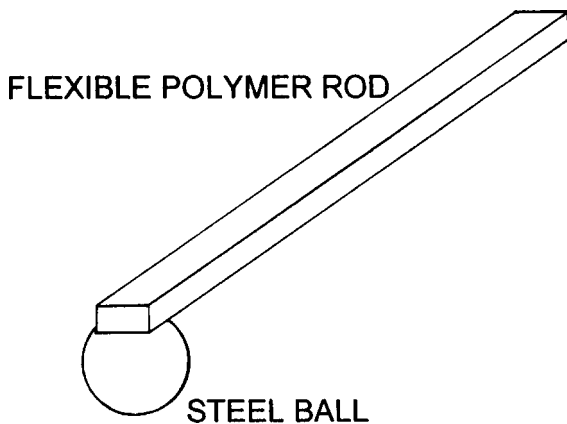

FIG. 2 Diagram of Typical Impulser for Small Specimens

range would be from 100 Hz to 50 kHz for most advanced ceramic test specimens. (Smaller and stiffer specimens vibrate at higher frequencies.) The frequency response of the transducer across the frequency range of interest shall have a bandwidth of at least 10 % of the maximum measured frequency before -3 dB power loss occurs.

7.4 Electronic System—The electronic system consists of a signal conditioner/amplifier, signal analyzer, and a frequency readout device. The system should have accuracy and precision sufficient to measure the frequencies of interest to an accuracy of 0.1 %. The signal conditioner/amplifier should be suitable to power the transducer and provide an appropriate amplified signal to the signal analyzer. The signal analysis system consists of a frequency counting device and a readout device. Appropriate devices are frequency counter systems with storage capability or digital storage oscilloscopes with a frequency counter module. With the digital storage oscilloscope, a Fast Fourier Transform signal analysis system may be useful for analyzing more complex waveforms and identifying the fundamental resonant frequency.

7.5 Support System—The support shall serve to isolate the specimen from extraneous vibration without restricting the desired mode of specimen vibration. Appropriate materials should be stable at the test temperatures. Support materials can be either soft or rigid for ambient conditions. Examples of soft materials would be a compliant elastomeric material, such as polyurethane foam strips. Such foam strips would have simple flat surfaces for the specimen to rest on. Rigid materials, such as metal or ceramic, should have sharp knife edges or cylindrical surfaces on which the specimen should rest. The rigid supports should be resting on isolation pads to prevent ambient vibrations from being picked up by the transducer. Wire suspension can also be used. Specimens shall be supported along node lines appropriate for the desired vibration in the locations described in Section 8.

8. Test Specimen

8.1 The specimens shall be prepared so that they are either rectangular or circular in cross section. Either geometry can be used to measure both dynamic Young's modulus and dynamic shear modulus. Although the equations for computing shear modulus with a cylindrical specimen are both simpler and more accurate than those used with a rectangular bar, experimental difficulties in obtaining torsional resonant frequencies for a cylindrical specimen usually preclude its use for determining shear modulus.

8.2 Resonant frequencies for a given specimen are functions of the specimen dimensions as well as its mass and moduli; dimensions should therefore be selected with this relationship in mind. The selection of size shall be made so that, for an estimated modulus, the resonant frequencies measured will fall within the range of frequency response of the transducers and electronics used. For a slender rod, the ratio of length to minimum cross-sectional dimension shall have a value of at least 5. However, a ratio of approximately 20 ≈ 25 is preferred for ease in calculation. For shear modulus measurements of rectangular bars, a ratio of width to thickness of 5 or greater is recommended for minimizing experimental difficulties.

8.3 All surfaces on the rectangular specimen shall be flat.

Opposite surfaces across the length, thickness, and width shall be parallel to within 0.1 %. The cylindrical specimen shall be round and constant in diameter to within 0.1 %.

8.4 Specimen mass shall be determined to within 0.1 %.

8.5 Specimen length shall be measured to within 0.1 %. The thickness and width of the rectangular specimen shall be measured to within 0.1 % at three locations and an average determined. The diameter of the cylindrical specimen shall be measured to within 0.1 % at three locations and an average determined.

8.6 Table 1 illustrates how uncertainties in the measured parameters influence the calculated modulus. It shows that calculations are most sensitive to error in the measurement of the thickness. Special care must be taken when measuring the thickness of samples with a thickness of less than 3 mm.

9. Procedure

9.1 Activate all electrical equipment, and allow it to stabilize according to the manufacturer’s recommendations.

9.2 Use a test specimen established as a verification/calibration standard to verify the equipment response and accuracy.

9.3 *Fundamental Flexural Resonant Frequency (Out-of-Plane Flexure):*

9.3.1 Place the specimen on the supports located at the fundamental nodal points (0.224 L from each end; see Fig. 3).

9.3.2 Determine the direction of maximum sensitivity for the transducer. Orient the transducer so that it will detect the desired vibration.

9.3.2.1 *Direct Contact Transducers*—Place the transducer in contact with the test specimen to pick up the desired vibration. If the transducer is placed at an antinode (location of maximum displacement), it may mass load the specimen and modify the natural vibration. The transducer should preferably be placed only as far from the nodal points as necessary to obtain a reading (see Fig. 3). This location will minimize the damping effect from the contacting transducer. The transducer contact force should be consistent, with good response and minimal interference with the free vibration of the specimen.

9.3.2.2 *Non Contact Transducers*—Place the non-contact transducer over an antinode point and close enough to the test specimen to pick up the desired vibration, but not so close as to interfere with the free vibration (see Fig. 3).

9.3.3 Strike the specimen lightly and elastically, either at the center of the specimen or at the opposite end of the specimen from the detecting transducer (see Fig. 3).

9.3.4 Record the resultant reading, and repeat the test until five consecutive readings are obtained that lie within 1 % of each other. Use the average of these five readings to determine the fundamental resonant frequency in flexure.

9.4 *Fundamental Flexural Resonant Frequency (In-Plane Flexure):*

9.4.1 This procedure is the same as 9.3, except that the direction of vibration is in the major plane of the specimen. This measurement can be performed in two ways. In one case, move the transducer and impulser 90° around the long axis of the test specimen to introduce and detect vibrations in the major plane (see Fig. 3). In the alternate method, rotate the test bar 90° around its long axis and reposition it on the specimen supports. Transpose the width and thickness dimensions in the calculations. For homogeneous, isotropic materials, the calculated moduli should be the same as the moduli calculated from the out-of-plane frequency. The comparison of in-plane and out-of-plane frequency measurements can thus be used as a cross check of experimental methods and calculations.

9.5 *Fundamental Torsional Resonant Frequency:*

9.5.1 Support the specimen at the midpoint of its length and width (the torsional nodal planes) (see Fig. 4).

9.5.2 Locate the transducer at one quadrant of the specimen, preferably at approximately 0.224 L from one end and toward the edge. This location is a nodal point of flexural vibration and will minimize the possibility of detecting a spurious flexural mode (see Fig. 4).

9.5.3 Strike the specimen on the quadrant diagonally opposite the transducer, again at 0.224 L from the end and near the edge. Striking at a flexural nodal point will minimize the possibility of exciting a flexural mode of vibration (see Fig. 4).

9.5.4 Record the resultant reading, and repeat the test until five consecutive readings are obtained that lie within 1 % of each other. Use the average of these five readings to determine the fundamental resonant frequency in torsion.

9.6 *Fundamental Longitudinal Resonant Frequency:*

9.6.1 Support the specimen at the midpoint of its length and width (the same as for torsion), or brace the specimen at its mid length, the fundamental longitudinal nodal position.

9.6.2 Locate the detecting transducer at the center of one of the end faces of the specimen.

9.6.3 Strike the end face of the specimen opposite to the face where the transducer is located.

9.6.4 Record the resultant reading, and repeat the test, until five consecutive readings are obtained that lie within 1 % of each other. Use the average of these five readings to determine the fundamental longitudinal resonant frequency.

TABLE 1 Effects of Variable Error on Modulus Calculation

Variable	Measurement Error	Variable Exponent in Modulus Equation	Calculation Error
Frequency (<i>f</i>)	0.1 %	<i>f</i> ²	0.2 %
Length (<i>L</i>)	0.1 %	<i>L</i> ³	0.3 %
Mass (<i>m</i>)	0.1 %	<i>m</i>	0.1 %
Width (<i>b</i>)	0.1 %	<i>b</i> ⁻¹	0.1 %
Thickness (<i>t</i>)	0.1 %	<i>t</i> ⁻³	0.3 %
Diameter (<i>D</i>)	0.1 %	<i>D</i> ⁻⁴	0.4 %

10. Calculation

10.1 *Dynamic Young’s Modulus (2, 3):*

10.1.1 For the fundamental flexure frequency of a rectangular bar (2),

$$E = 0.9465(mf_f^2/b)(L^3/t^3)T_1 \tag{2}$$

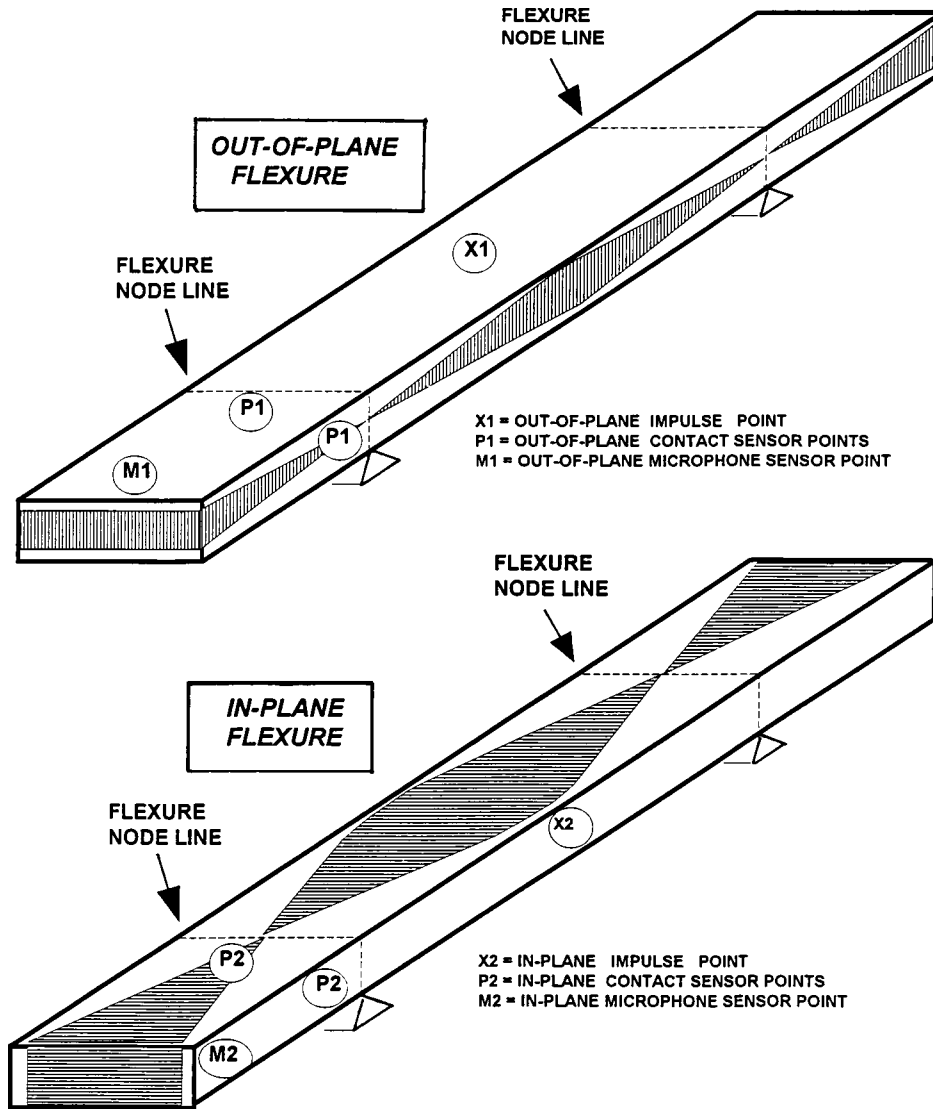

FIG. 3 Rectangular Specimens Tested for In-Plane and Out-of-Plane Flexure

where:

- E = Young's modulus, Pa,
- m = mass of the bar, g (see Note 1),
- b = width of the bar, mm (see Note 1),
- L = length of the bar, mm (see Note 1),
- t = thickness of the bar, mm (see Note 1),
- f_f = fundamental resonant frequency of bar in flexure, Hz, and
- T_1 = correction factor for fundamental flexural mode to account for finite thickness of bar, Poisson's ratio, and so forth.

$$T_1 = 1 + 6.585 (1 + 0.0752 \mu + 0.8109 \mu^2) (t/L)^2 - 0.868 (t/L)^4 - \left[\frac{8.340 (1 + 0.2023 \mu + 2.173 \mu^2) (t/L)^4}{1.000 + 6.338 (1 + 0.1408 \mu + 1.536 \mu^2) (t/L)^2} \right] \quad (3)$$

where:

μ = Poisson's ratio.

NOTE 1—In the modulus equations, the mass and length terms are given in units of grams and millimetres. However, the defined equations can also be used with mass and length terms in units of kilograms and metres with no changes in terms or exponents.

10.1.1.1 If $L/t \geq 20$, T_1 can be simplified to the following:

$$T_1 = [1.000 + 6.585 (t/L)^2] \quad (4)$$

and E can be calculated directly.

10.1.1.2 If $L/t < 20$ and Poisson's ratio is known, then T_1 can be calculated directly from Eq 3 and then used to calculate E .

10.1.1.3 If $L/t < 20$ and Poisson's ratio is not known, then an initial Poisson's ratio must be assumed to begin the computations. An iterative process is then used to determine a value of Poisson's ratio, based on experimental Young's modulus and shear modulus. The iterative process is flowcharted in Fig. 5 and described in (1) through (5),

(1) Determine the fundamental flexural and torsional resonant frequency of the rectangular test specimen, as described in Section 9. Using Eq 12 and Eq 13, calculate the dynamic shear modulus of the test specimen for the fundamental torsional resonant frequency.

(2) Using Eq 2 and Eq 3, calculate the dynamic Young's modulus of the rectangular test specimen from the fundamental flexural resonant frequency, dimensions and mass of the specimen, and initial/iterative Poisson's ratio. Care must be

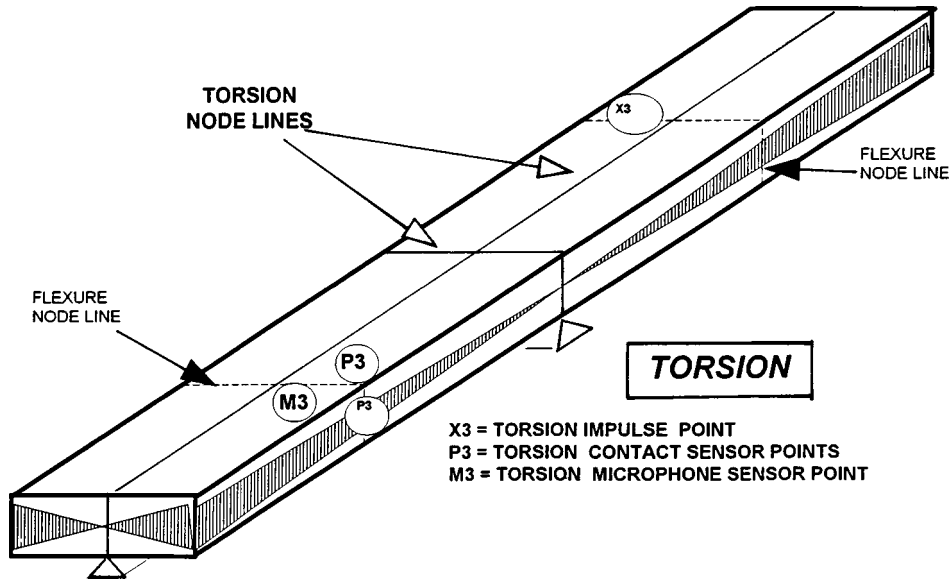

FIG. 4 Rectangular Specimen Tested for Torsional Vibration

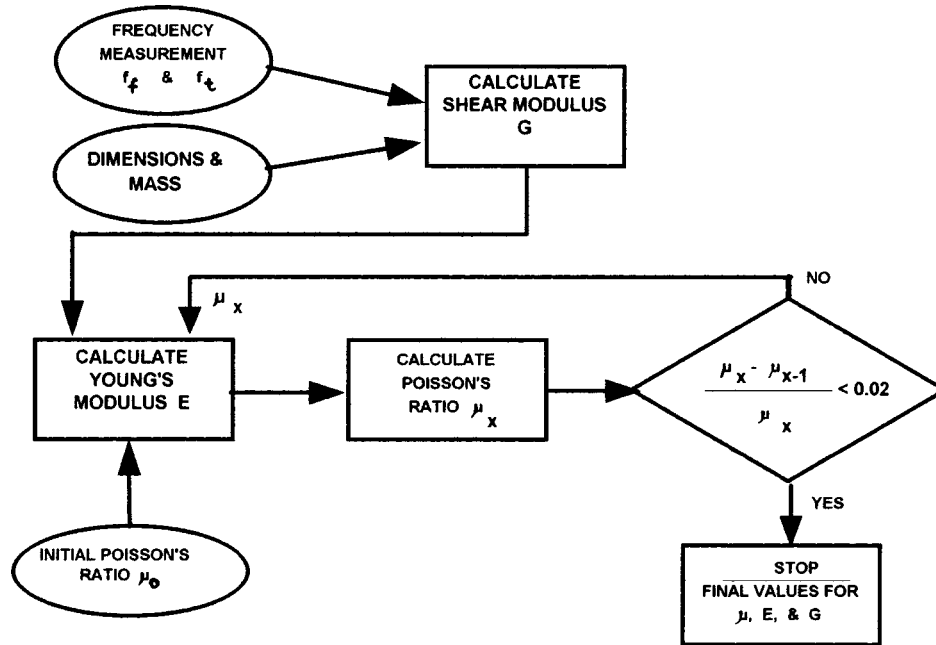

FIG. 5 Process Flow Chart for Iterative Determination of Poisson's Ratio

exercised in using consistent units for all of the parameters throughout the computations.

(3) Substitute the dynamic shear modulus and Young's modulus values calculated in steps (1) and (2) into Eq 16 for Poisson's ratio satisfying isotropic conditions. Calculate a new value for Poisson's ratio for another iteration beginning at Step (2).

(4) Repeat Steps (2) and (3) until no significant difference (2 % or less) is observed between the last iterative value and the final computed value of the Poisson's ratio.

(5) Self-consistent values for the moduli are thus obtained.

10.1.2 For the fundamental flexural frequency of a rod of circular cross section (2):

$$E = 1.6067(L^3/D^4)(mf_f^2)T_1' \quad (5)$$

where:

D = diameter of rod, mm (see Note 1), and
 T_1' = correction factor for fundamental flexural mode to account for finite diameter of rod, Poisson's ratio, and so forth.

$$T_1' = 1 + 4.939 (1 + 0.0752 \mu + 0.8109 \mu^2) (D/L)^2 - 0.4883 (D/L)^4 \quad (6)$$

$$= \left[\frac{4.691 (1 + 0.2023 \mu + 2.173 \mu^2) (D/L)^4}{1.000 + 4.754 (1 + 0.1408 \mu + 1.536 \mu^2) (D/L)^2} \right]$$

10.1.2.1 If $L/D \geq 20$, then T_1' can be simplified to the following:

$$T_1' = [1.000 + 4.939 (D/L)^2] \quad (7)$$

10.1.2.2 If $L/D < 20$ and Poisson's ratio is known, then T_1' can be calculated directly from Eq 6 and then used to calculate E .

10.1.2.3 If $L/D < 20$ and Poisson's ratio is not known, then an initial Poisson's ratio must be assumed to start the computations. Final values for Poisson's ratio, dynamic Young's modulus, and dynamic shear modulus are determined, using the same method shown in Fig. 5 and described in (I) through (5) in 10.1.1.3, but using the modulus equations for circular bars (Eq 5, Eq 6, and Eq 15).

10.1.3 For the fundamental longitudinal frequency of a slender bar with circular, square or rectangular cross-section

$$E = (\rho/K) (2L f_1)^2 \quad (8)$$

- ρ = density of the material, g/mm^3
- f_1 = fundamental longitudinal frequency of bar, Hz
- K = correction factor for the fundamental longitudinal mode to account for the finite diameter-to-length ratio and Poisson's Ratio:

$$K = 1 - [(\pi^2 \mu^2 D_e^2) / (8 L^2)] \quad (9)$$

- μ = Poisson's ratio
- D_e = the effective diameter of the bar
- For a circular cross section bar:

- D_e^2 = the second power of the diameter (mm) of the bar
- For a square cross-section bar:

$$D_e^2 = 4 b^2 / 3 \quad (10)$$

- where:
- b = the width/thickness of the square cross section, mm
- For a rectangular cross section bar:

$$D_e^2 = 2 (b^2 + t^2) / 3 \quad (11)$$

- where:
- b = the width of the rectangular cross-section, mm
- t = the thickness of the rectangular cross-section, mm

10.2 Dynamic Shear Modulus (4):

10.2.1 For the fundamental torsional frequency of a rectangular bar (4):

$$G = \frac{4 L m f_t^2}{b t} [B / (1 + A)] \quad (12)$$

- where:
- G = dynamic shear modulus, Pa,
- f_t = fundamental resonant frequency of bar in torsion Hz.

$$B = \left[\frac{b/t + t/b}{4 (t/b) - 2.52 (t/b)^2 + 0.21 (t/b)^6} \right] \quad (13)$$

and
 A = an empirical correction factor dependent on the width-to-thickness ratio of the test specimen (5). This correction factor has an effect of less than 2 % and can be omitted, unless accuracies of better than 2 % are desired. (See Fig. 6 for a plot of A as a function of the width-to-thickness ratio.) An empirical equation fitted to the points from Fig. 6 is given in Eq 14.

$$A = \frac{[0.5062 - 0.8776 (b/t) + 0.3504 (b/t)^2 - 0.0078 (b/t)^3]}{[12.03 (b/t) + 9.892 (b/t)^2]} \quad (14)$$

10.2.2 For the fundamental torsion frequency of a cylindrical rod (3):

$$G = 16 m f_t^2 (L / \pi D^2) \quad (15)$$

10.3 Poisson's Ratio:

$$\mu = (E/2G) - 1 \quad (16)$$

- where:
- μ = Poisson's ratio,
- E = Young's modulus, and
- G = shear modulus.

If Poisson's ratio is not known or assumed, then the iterative process (described in Section 10.1.1.3) must be used to determine an experimental Poisson's ratio, using the appropriate equations for Young's modulus and shear modulus and the experimental geometry (round, square, or rectangular cross section) (Fig. 7).

10.4 If measurements are made at elevated or cryogenic temperatures, the calculated moduli must be corrected for thermal expansion effects using Eq 17.

$$M_T = M_o [f_T / f_o]^2 [1 / (1 + \alpha \Delta T)] \quad (17)$$

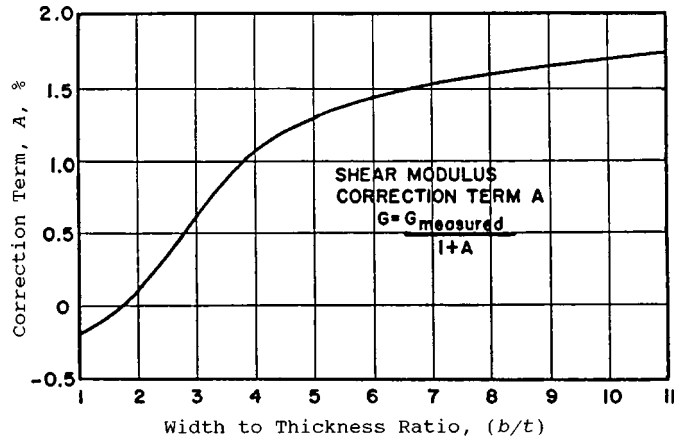

FIG. 6 Plot of the Shear Modulus Correction Term A

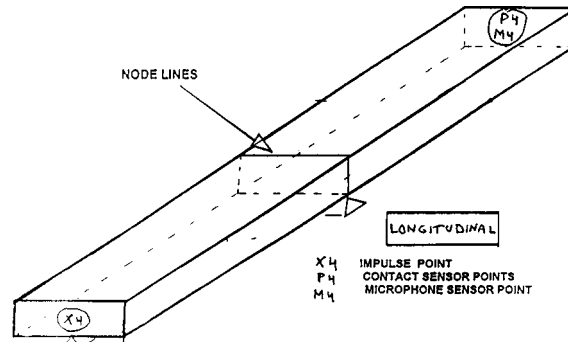

FIG. 7 Rectangular Specimen Tested for Longitudinal Vibration

where:

M_T = modulus at temperature T (either Young's modulus E or shear modulus G),

M_o = modulus at room temperature (either Young's modulus E or shear modulus G),

f_T = resonant frequency in furnace or cryogenic chamber at temperature T ,

f_o = resonant frequency at room temperature in furnace or cryogenic chamber,

α = average linear thermal expansion (mm/mm·°C) from room temperature to test temperature (Test Method C 372 is recommended), and

ΔT = temperature differential in °C between test temperature T and room temperature.

10.5 Use the following stress conversion factor for English units.

$$1 \text{ Pa} = 1.450 \times 10^{-4} \text{ psi} \quad (18)$$

11. Report

11.1 Report the following information:

11.1.1 Identification of specific tests performed, a detailed description of apparatus used (impulser, transducer, electrical system, and support system), and an explanation of any deviations from the described test method.

11.1.2 Complete description of material(s) tested stating composition, number of specimens, specimen geometry and mass, specimen history, and any treatments to which the specimens have been subjected. Include comments on dimensional variability, surface finish, edge conditions, observed changes after cryogenic or high-temperature testing, and so forth, where pertinent.

11.1.3 Specimen temperature at measurement, number of measurements taken, numerical values obtained for measured fundamental resonant frequencies, and the calculated values for dynamic Young's modulus, dynamic shear modulus, Poisson's ratio for each specimen tested.

11.1.4 Date of test and name of the person performing the test.

11.1.5 Laboratory notebook number and page on which test data are recorded or the computer data file name, or both, if used.

12. Precision and Bias

12.1 An evaluation (6) was conducted and published in 1990, by Smith, Wyrick, and Poole, of three different methods

of modulus measurement of mechanically alloyed materials. As part of that evaluation, the impulse modulus measurement method,⁷ using a commercial instrument, was used. With that instrument, the precision of the impulse method was measured using a NIST Standard Reference Material 718 (alumina reference bar No. C1) in flexural vibration. The NIST standard had a measured and specified fundamental flexural frequency of 2043.3 Hz. The fundamental flexural resonant frequency of the NIST reference bar was measured by the impulse method and reported by Smith, Wyrick, and Poole as 2044.6 Hz. This was a percentage error of +0.06 %, indicating the level of bias that is achievable with the impulse method.

12.2 An intralaboratory round-robin test was conducted in 1993 to measure the precision of frequency measurement on two monolithic ceramic test bars. A bias test was not conducted because suitable standard reference bars were not readily available.

12.2.1 The tests were conducted with an alumina test bar (10 g, 83.0 by 6.9 by 4.8 mm) and a silicon nitride bar (2.0 g, 50 by 4.0 by 3.0 mm). The silicon nitride bar was machined to Test Method C 1161 tolerances; the alumina bar was not machined and varied from 4.5 to 4.8 mm in thickness along its length. The variations in the alumina bar thickness were deliberate; it provided a test of the robustness of the frequency measurement technique.

12.2.2 Torsional frequency measurements were not performed because the width-thickness ratio of the bars was not suitable for torsional frequency measurements.

12.2.3 The bars were tested in flexural vibration at eight laboratories using ten combinations of different frequency analyzer test systems, impulsers, contact and non contact transducers, and supports systems. For the alumina bar, the mean measured flexural frequency for the ten tests was 6581 Hz, with a standard deviation of 20 Hz. This corresponds to a coefficient of variation of 0.3 %. For the silicon nitride bar, the mean measured flexural frequency for the ten tests was 11 598 Hz, with a standard deviation of 34 Hz. This corresponds to a coefficient of variation of 0.3 %.

12.2.4 The intralaboratory study did show that individuals with experience in using the impulse test method for a given specimen geometry produced data sets with smaller standard deviations. For example, with the alumina test bar, the coefficients of variation for individual laboratories ranged from 0.001 to 0.6 % among the ten test sets. For the silicon nitride bar, the range of coefficients of variation was 0.001 to 1.0 % for

the individual laboratories.

12.2.5 Based on this intralaboratory study of the impulse test method, the repeatability and reproducibility coefficients at the 95 % confidence level are listed in Table 2.

12.3 A propagation of errors analysis of the equations for E and G using the stated tolerances for dimensions, mass, and frequency measurements in this test method has shown that a 0.1 % error in the measurement of the key variables produces a range of errors in the calculation of the modulus based on the

variable exponent in the equations. Table 1 gives the calculation error effects of errors in the different experimental variables.

12.4 It is expected that the major sources of experimental variation in modulus values for this test method will be in two measurements—the fundamental frequency and the smallest dimension (thickness/diameter) of the test bars. If a fundamental resonant frequency of 6000 Hz is measurable to an accuracy of 18 Hz/(0.3 %) and a 3-mm thick bar is parallel and measured to an accuracy of 0.01 mm (0.3 %), the error in the thickness measurement will have the greater effect on the modulus calculation (0.9 % for thickness error versus 0.6 % for frequency error).

13. Keywords

13.1 dynamic; elastic modulus; elastic properties; impulse; Poisson's ratio; shear modulus; Young's modulus

TABLE 2 Within- and Between-Laboratory Precision

Test Bar No. and Type	Al ₂ O ₃	Si ₃ N ₄
Measured fund, flexural frequency (Hz)	6581	11 598
95 % repeatability limit (within laboratory) CV, % ^A	0.9 %	1.1 %
95 % reproducibility limit (between laboratories) CV, % _R ^A	1.2 %	1.3 %

^ACalculated in accordance with Practice E 177, Section 28.

ANNEX

A1. (DISC-SHAPED SPECIMENS) FOR DYNAMIC YOUNG'S MODULUS, SHEAR MODULUS, AND POISSON'S RATIO BY IMPULSE EXCITATION OF VIBRATION

A1.1 Scope

A1.1.1 This annex covers the evaluation of disc geometry specimens for the determination of the dynamic elastic properties of elastic materials at ambient temperatures. With a disc-shaped specimen, the Poisson's ratio is determined using the resonant frequencies of the first two natural vibration modes. The dynamic Young's modulus and dynamic shear modulus are then calculated using the Poisson's ratio, the experimentally-determined fundamental resonant frequencies, and the specimen dimensions and mass.

A1.1.2 In testing disc specimens for Young's modulus, shear modulus, and Poisson's ratio, the disc geometry requires a significantly different set of equations and method of calculation and some minor changes in procedures. This annex describes those variations as they relate to terminology, test specimens, procedures and calculations for the disc geometry specimens. However, the general methods, references, terminology, significance, interferences, apparatus, specimen requirements, and procedures described in the main body of the test method are still pertinent to the test procedure and the results.

A1.1.3 The use of the disc geometry is suitable for monolithic and particulate/whisker/fiber reinforced materials. However, the disc geometry is not recommended for continuous fiber reinforced composite materials because of the anisotropy in mechanical properties and the difficulty in determining orientation effects on the measured frequencies.

A1.2 Terminology

A1.2.1 *Description of Terms Specific to this Annex for Disc-Shaped Specimens*

A1.2.1.1 *anti-nodes, n*—two or more locations that have local maximum displacements in an unconstrained resonant specimen.

A1.2.1.2 *first natural vibration, n*—the vibrations that occur when the displacements in the cross-sectional plane (the plane that is parallel to the flat of the disc) are normal to the plane and symmetrical around two orthogonal diameters in the plane of the disc, producing a twisting of the disc. This is an orthogonal anti-flexural mode of vibration (7). For the first natural vibration mode, the nodes are located along two orthogonal diameters, offset 45° from the point where the vibration was induced. The anti-nodes are located along two orthogonal (90° offset) diameters in the disc, with one diameter intersecting the point where the vibration was induced. See Fig. A1.1, which shows a finite element map of anti-flexural displacement in a disc and a schematic of the nodal and antinodal lines for the first natural vibration of the disc).

A1.2.1.3 *nodes, n*—one or more locations that have a constant zero displacement in an unconstrained resonant specimen.

A1.2.1.4 *second natural vibration, n*—the vibrations that occur when the displacements in the cross-sectional plane (the plane that is parallel to the flat of the disc) are normal to the plane and are uniform in displacement for a given radial distance from the center point through the entire 360° arc. This is axisymmetric flexural vibration (7). For the second natural vibration mode of a disc, the nodes are located in a circle concentric with the center of the disc with a fractional radius of 0.681 of the disc radius. The anti-nodes are located at the center and around the circumference of the disc specimen. See Fig. A1.2, which shows a finite element map of axisymmetric flexural displacement in a disc and a schematic of the nodal circle and the antinodal points and line for the second natural vibration of the disc).

A1.3 Test Specimen

A1.3.1 Fabricate the specimens so that they are disc-shaped with a diameter-to-thickness ratio of at least four, with a value

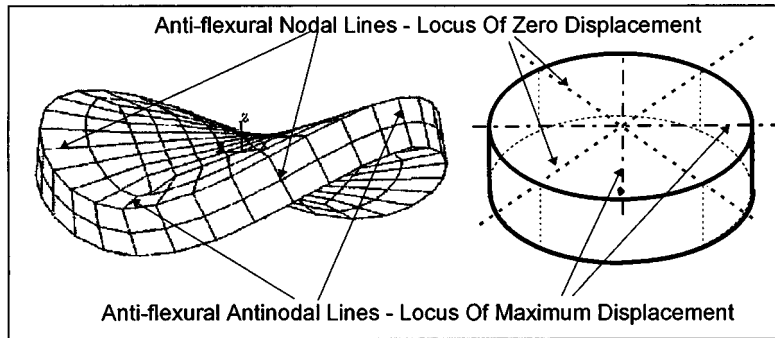

FIG. A1.1 Displacement Diagram for Disc-Shaped Specimen in First Natural Vibration

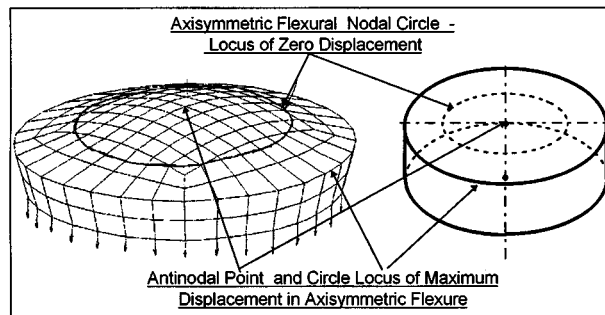

FIG. A1.2 Displacement Diagram for Disc-Shaped Specimen in Second Natural Vibration Mode

of 10-20 recommended for experimental simplicity. Resonant frequencies for a given specimen are a function of the specimen dimensions as well as its mass and moduli; therefore, dimensions should be selected with this relationship in mind. By using approximate specimen dimensions and estimated values for the moduli and Poisson's ratio, nominal resonant frequencies can be calculated with the formulas in Section A5. By adjusting the size of the specimen, the resonant frequencies can be tuned into the measurement range of the transducers and electronics. The dimensional tolerances for the thickness, diameter, and flatness are given in A1.3.2-A1.3.5.

A1.3.2 Measure the specimen thickness within 0.1 % at five locations (one at the center, two at the outer edge, and two at the $\frac{1}{2}$ radius). Determine the average of the five measurements for a specimen thickness.

A1.3.3 Ensure that the thickness of the disc is uniform so that opposite plane surfaces of the disc are parallel to within 0.1 % of the thickness, whichever is greater. For larger discs where precision machining of the thickness to those tolerances is difficult, an alternative tolerance of 0.01 mm or ± 0.5 % is allowed, with proper allowances for the resulting loss of precision in the calculated modulus. The use of the less precise tolerance for the thickness should be noted in the report.

A1.3.4 Measure the specimen diameter within 0.1 % at four locations (45° intervals around the circumference, as shown in Fig. A1.3.) Determine an average from the four measurements. Ensure that the diameter of the disc is uniform to within ± 0.1 %, whichever is greater. (The value of the radius is used to determine the Poisson's ratio.)

A1.3.5 Measure the flatness of the disc resting on a surface plate with a dial gage, taking measurements at nine locations (one at the center, four at the outer edge, and four at the $\frac{1}{2}$ radius) on the disc. Turn the disc over and repeat the measure-

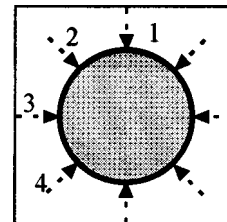

FIG. A1.3 Diameter Measurement Locations

ment on the opposite face. The maximum difference between any two measurements on a face must not exceed 0.1 % of the diameter.

A1.3.6 Determine the specimen mass to the nearest 10 mg or 0.1 % of the total weight, whichever is greater.

A1.3.7 All other specimen requirements and recommendations as described in Section 8 of the main body of this standard are pertinent to the disc-shaped specimens.

A1.4 Procedure

A1.4.1 Active and allow all electrical equipment to stabilize according to manufacturer's recommendations.

A1.4.2 Use a test specimen established as an "in-house" verification standard to check the operation of the test system. The "in-house" standard can also be used to verify the operation, repeatability, and precision of the system and the operator. The standard specimen should have a geometry similar in size and shape to the experimental specimens.

A1.4.3 First Natural Resonant Frequency

A1.4.3.1 Specimens can be supported either on soft polyurethane foam strips or on four hard support points. Specimens with a low (<10) diameter-to-thickness ratio may be supported on flat strips of soft polyurethane foam set in an x-pattern.

Experience has shown that foam supports are more compliant than hard supports and markedly reduce rattling and extraneous vibrations in the test. If foam supports are not available, place the specimen on four hard support points located at the intersections of the nodal diameters of the first natural vibration with the nodal circle of the second natural vibration (see Fig. A1.4). Generally, visual positioning is sufficiently accurate for larger specimens (diameter >75 mm). Specimens with a high (>20) diameter-to-thickness ratio or a smaller diameter (<75 mm) will require more accurate positioning.

NOTE A1.1—For precise support location, the nodal circle diameter of the test specimen can be calculated as 0.681 of the geometrical mean diameter. Then draw, or otherwise define, the nodal circle of this diameter on a piece of paper so that it is concentric with a circle drawn slightly larger than the diameter of the test piece specimen. Locate four equally disposed positions around the nodal circle to define the support points (see Fig. A1.4). Place the supports at these positions and then place the test specimen on the supports so that the specimen is visually concentric with the second larger drawn circle.

A1.4.3.2 Follow section 9.3.2 in the main body for orienting and using contact and non-contact transducers. Determine the direction of maximum sensitivity for the transducer. Orient the transducer so that it will detect the desired vibration.

A1.4.3.3 For the first natural vibration Fig. A1.5 shows the impulse and sensor points. Locate the transducer on a point (S1 in Fig. A1.5) on the second mode nodal circle on the flat of the disc and offset by 45° from a support point. Strike the specimen on the flat of the disc (X1 in Fig. A1.5) 90° away from the transducer point. Striking at the second mode nodal circle will minimize the possibility of exciting that particular mode of vibration.

NOTE A1.2—Accuracy and repeatability in the impulse excitation test depend upon developing and detecting a single vibration mode in the test specimen, without introducing and detecting alternative vibration modes in the specimen. Exciting and detecting a singular vibration mode for a simple geometry of suitable size depends on three experimental variables:

- the alignment of the support points with the specimen nodal points to favor the desired vibration mode and to minimize interference
- the location of the strike point at the antinode of the desired vibration mode and an elastic (rapid with short duration contact) method of striking
- the positioning of the detection transducer at a point where the desired vibration mode is active, but where there is minimal interference from competitive vibrations

With a minimal amount of experience and practice on a suitable specimen geometry, most operators can obtain repeatability and accuracy on the order of 1 % or better in a series of repeated test strikes. For a specific specimen, the first test strikes are a means of determining the appropriate locations and methods of specimen support, striking, and signal detection. By slight shifts in those positions and repeated test

strikes, the proficient operator can find the appropriate locations to achieve the consistent 1 % repeatability in a series of five consecutive readings. This is an iterative process for every new specimen; but can be done quickly by those operators who have experience with specimens of different sizes and compositions.

A1.4.3.4 After repeatability of the test procedure has been demonstrated, take and record at least five (5) readings. Use the average of these five readings to determine the first natural frequency (f_1). If readings repeat with a variation greater than 1 %, the operator shall review the measurement technique (supports, tap/sensor location, tapping mode) and the integrity/geometry of the test specimen.

NOTE A1.3—Adjustments and improved consistency in technique may improve the repeatability. Measurement technique can also be checked for consistency by taking measurements on “in-house” calibration standards. If technique adjustments do not improve the repeatability for the experimental specimens, the operator should determine what the source of the variation is. There are two possible causes for this variation:

- a geometry in which two vibration modes exist with similar frequencies that interfere during the measurement
- inhomogeneities/flaws in the test specimens which produce spurious vibrations or very rapid damping

In the case of specimens with vibration modes that are similar in frequency, the vibration of interest can be enhanced and the undesirable vibration can be diminished, based on iterative changes in technique (support/tap/sensor location, tapping mode).

For example, samples of rolled sheet may exhibit poor repeatability. Gradually rotating the sample will result in a sample position with good repeatability for the first mode. Rotating the sample another 45° will result in another position with good repeatability for the first mode.

A1.4.4 *Second Natural Resonant Frequency*

A1.4.4.1 The specimen is supported at the same points used for the first natural frequency support—the intersection of the first natural frequency nodal diameters with the second natural frequency nodal circle (Fig. A1.4).

A1.4.4.2 Position the transducer on the flat of the disc close to the outer circumference (S2 in Fig. A1.5). Then strike the disc specimen lightly at the center of the specimen (X2 in Fig. A1.5).

A1.4.4.3 After repeatability of the test procedure has been demonstrated, the operator takes at least five (5) readings. Use the average of these five readings to determine the second natural frequency (f_2). If the readings vary by more than 1 % of each other, the operator shall review the measurement technique. [See Notes 2 and 3 following sections A1.4.3.3 and A1.4.3.4]

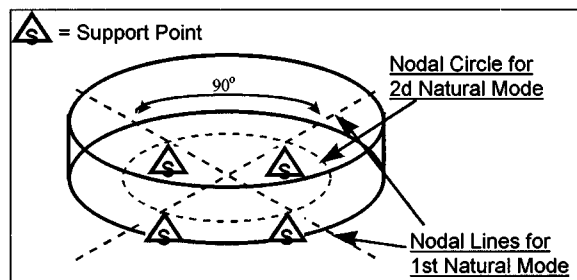

FIG. A1.4 Support Points for 1st and 2^d Natural Vibrations in Discs

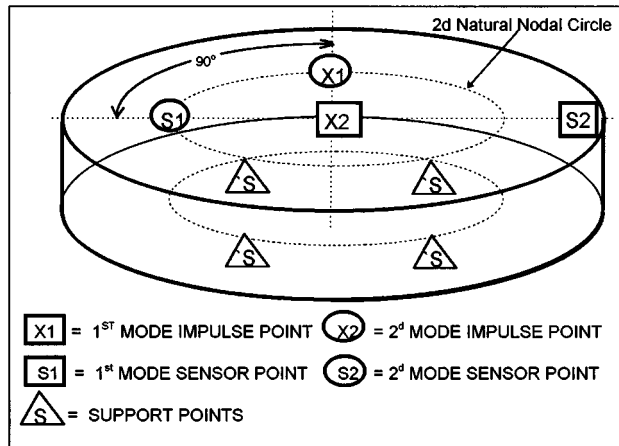

FIG. A1.5 Impulse and Sensor Points for 1ST and 2^d Natural Vibration in Discs

A1.5 Calculations

A1.5.1 The derivation and use of the equations for calculating the Poisson's ratio and moduli from disc-shaped specimens are described in detail in two Refs (8, 9). The Martineck reference (8) gives the derivation and procedures for the baseline calculation. The fundamental equation defining the relationship between the natural resonant frequency, the material properties, and the specimen dimensions is given by Martineck as:

$$f_i = \frac{K_i}{2\pi r^2} \sqrt{\frac{A}{\rho t}} \quad (A1.1)$$

where f_i is the resonant frequency of interest, K_i is the geometric factor for that resonant frequency, r is the radius of the disc, A is the plate constant ($A = Et^3/[12(1-\mu^2)]$), t is the disc thickness, ρ is the density of the disc, E is Young's modulus of elasticity, and μ is the Poisson's ratio for the disc material. This is a general equation which is valid for both the first natural and second natural vibrations. The Glandus reference supplements the Martineck article with more extensive tables for the geometric factors K_i and for determining Poisson's ratio. The overall method for calculating the Poisson's ratio, Young's modulus, and the shear modulus from the first natural and second natural frequencies is described by Martineck and by Glandus as the following three-step procedure.

(1) Determine the Poisson's ratio from the experimental values for the first and second natural resonant frequencies.

(2) Calculate two independent values for E (Young's modulus of elasticity) using the Poisson's ratio from step 1 and the first natural and second natural resonant frequencies. Determine E as the average of the two independent calculations.

(3) Calculate the value of G (Shear Modulus) using the Poisson's ratio from step 1 and the calculated value of E from step 2.

The details for each calculation are given in the following sections.

A1.5.2 Poisson's Ratio (8,9)

For the disc-shaped specimen, Poisson's ratio (μ) can be determined directly from the experimental values of the first natural resonant frequency (f_1) and the second natural resonant frequency (f_2). This is done by the use of Table A1.1, in which

the value for Poisson's ratio (μ) is interpolated from the table using the ratio of the second natural resonant frequency to the first natural resonant frequency (f_2/f_1) correlated with the ratio of the specimen thickness to the specimen radius (t/r).

For example, if the ratio (f_2/f_1) of the two experimental resonant frequencies is 1.55 and the thickness of the disc is 3 mm and the diameter is 30 mm (giving a t/r ratio of 0.20), then the Poisson's ratio is 0.218 from the 9th column and 5th row of the table.

A1.5.3 Dynamic Young's Modulus (8,9)

A1.5.3.1 For the Young's modulus of a disc, two calculations of E (E_1 and E_2) are made independently from the two resonant frequency measurements, and then a final value E is determined by averaging the two calculated values E_1 and E_2 .

$$E_1 = [37.6991 f_1^2 D^2 m (1 - \mu^2)] / (K_1^2 t^3) \quad (A1.2)$$

$$E_2 = [37.6991 f_2^2 D^2 m (1 - \mu^2)] / (K_2^2 t^3) \quad (A1.3)$$

$$E = (E_1 + E_2)/2 \quad (A1.4)$$

where:

E = Young's modulus (Pa)

E_1 = first natural calculation of Young's modulus

E_2 = second natural calculation of Young's modulus

f_1 = first natural resonant frequency (Hz) of the disc

f_2 = second natural resonant frequency (Hz) of the disc

D = diameter (mm) of the disc

m = mass (g) of the disc

μ = Poisson's ratio for the specimen as determined in Section A1.5.2

K_1 = first natural geometric factor from Table A1.2A & Table A1.2B (using linear interpolation as necessary)

K_2 = second natural geometric factor from Table A1.3A and Table A1.3B (using linear interpolation as necessary)

t = thickness (mm) of the disc

r = radius (mm) of the disc

NOTE A1.4—The two tables in sets A-II and A-III give two different ranges for the independent variables t/r and μ . The first table (A) gives the full range ($t/r = 0.0$ to 0.50 and $\mu = 0$ to 0.50), while the second table (B)

TABLE A1.1 Poisson's Ratio (μ) Values (as a function of f_2/f_1 and t/r) [9]

f_2/f_1	1.350	1.375	1.400	1.425	1.450	1.475	1.500	1.525	1.550	1.575	1.600
t/r Ratio	POISSON'S RATIO (μ)										
0.00	0.015	0.043	0.070	0.094	0.118	0.141	0.163	0.184	0.205	0.226	0.247
0.05	0.018	0.044	0.070	0.094	0.118	0.141	0.164	0.185	0.206	0.226	0.247
0.10	0.020	0.045	0.070	0.094	0.118	0.141	0.164	0.185	0.206	0.227	0.247
0.15	0.023	0.049	0.075	0.100	0.124	0.148	0.171	0.192	0.212	0.233	0.254
0.20	0.025	0.053	0.080	0.105	0.130	0.154	0.178	0.198	0.218	0.239	0.260
0.25	0.033	0.060	0.088	0.114	0.139	0.162	0.186	0.206	0.227	0.247	0.268
0.30	0.040	0.068	0.096	0.122	0.148	0.171	0.193	0.214	0.235	0.255	0.275
0.35	0.051	0.078	0.105	0.130	0.155	0.179	0.203	0.224	0.245	0.264	0.284
0.40	0.062	0.088	0.113	0.138	0.162	0.187	0.212	0.234	0.255	0.274	0.292
0.45	0.070	0.096	0.123	0.148	0.173	0.197	0.221	0.242	0.263	0.281	0.300
0.50	0.078	0.105	0.132	0.158	0.183	0.206	0.229	0.250	0.270	0.289	0.307

f_2/f_1	1.625	1.650	1.675	1.700	1.725	1.750	1.775	1.800	1.825	1.850	1.875	1.900
t/r Ratio	POISSON'S RATIO (μ)											
0.00	0.265	0.282	0.297	0.312	0.329	0.346	0.362	0.378	0.394	0.409	0.424	0.438
0.05	0.265	0.283	0.298	0.314	0.331	0.347	0.363	0.378	0.394	0.409	0.424	0.438
0.10	0.265	0.283	0.300	0.316	0.332	0.348	0.363	0.378	0.394	0.409	0.424	0.438
0.15	0.271	0.289	0.306	0.322	0.338	0.354	0.368	0.383	0.398	0.413	0.427	0.442
0.20	0.278	0.295	0.312	0.328	0.344	0.359	0.374	0.388	0.403	0.417	0.431	0.445
0.25	0.286	0.304	0.320	0.336	0.351	0.366	0.380	0.395	0.409	0.423	0.437	0.451
0.30	0.294	0.312	0.328	0.344	0.358	0.372	0.387	0.402	0.415	0.428	0.442	0.456
0.35	0.302	0.320	0.336	0.352	0.367	0.382	0.398	0.414	0.428	0.442	0.456	0.471
0.40	0.310	0.328	0.344	0.360	0.376	0.392	0.409	0.425	0.440	0.455	0.470	0.485
0.45	0.318	0.337	0.354	0.370	0.387	0.403	0.420	0.437	0.452	0.468	0.485	0.503
0.50	0.327	0.346	0.363	0.380	0.397	0.414	0.431	0.448	0.464	0.480	0.500	0.520

TABLE A1.2 a K_1 Values (as a function of t/r and μ) [9]

t/r	0.000	0.050	0.100	0.150	0.200	0.250	0.300	0.350	0.400	0.450	0.500
μ	K_1 Value										
0.000	6.170	6.144	6.090	6.012	5.914	5.800	5.674	5.540	5.399	5.255	5.110
0.050	6.076	6.026	5.968	5.899	5.816	5.717	5.603	5.473	5.331	5.178	5.019
0.100	5.962	5.905	5.847	5.782	5.705	5.613	5.504	5.377	5.234	5.079	4.915
0.150	5.830	5.776	5.720	5.657	5.581	5.490	5.382	5.256	5.115	4.962	4.800
0.200	5.681	5.639	5.587	5.524	5.446	5.351	5.240	5.114	4.975	4.826	4.673
0.250	5.517	5.491	5.445	5.380	5.297	5.197	5.083	4.957	4.822	4.681	4.537
0.300	5.340	5.331	5.290	5.223	5.135	5.030	4.913	4.787	4.656	4.523	4.390
0.350	5.192	5.156	5.120	5.052	4.961	4.853	4.734	4.610	4.483	4.358	4.234
0.400	4.973	4.964	4.931	4.865	4.775	4.668	4.551	4.429	4.306	4.186	4.070
0.450	4.781	4.756	4.723	4.661	4.576	4.476	4.365	4.249	4.131	4.013	3.899
0.500	4.540	4.525	4.490	4.436	4.365	4.280	4.182	4.075	3.960	3.841	3.720

TABLE A1.2 b K_1 Values (as a function of t/r and μ) (9)

t/r	0.100	0.110	0.120	0.130	0.140	0.150	0.160	0.170	0.180	0.190	0.200
μ	K_1 Value										
0.14	5.746	5.739	5.722	5.710	5.696	5.683	5.670	5.654	5.642	5.629	5.608
0.16	5.694	5.687	5.670	5.664	5.645	5.632	5.619	5.602	5.590	5.576	5.556
0.18	5.641	5.634	5.617	5.606	5.592	5.579	5.566	5.549	5.537	5.523	5.502
0.2	5.587	5.576	5.563	5.551	5.538	5.524	5.510	5.495	5.479	5.463	5.446
0.22	5.531	5.524	5.507	5.495	5.481	5.468	5.455	5.439	5.427	5.411	5.388
0.24	5.474	5.467	5.450	5.438	5.424	5.410	5.396	5.379	5.366	5.351	5.328
0.26	5.415	5.408	5.391	5.379	5.364	5.350	5.336	5.318	5.304	5.289	5.266
0.28	5.354	5.347	5.330	5.317	5.301	5.287	5.273	5.255	5.241	5.225	5.201
0.30	5.290	5.279	5.266	5.253	5.238	5.223	5.207	5.190	5.173	5.154	5.135
0.32	5.224	5.217	5.200	5.187	5.172	5.157	5.142	5.123	5.108	5.091	5.067
0.34	5.156	5.148	5.131	5.118	5.103	5.088	5.073	5.053	5.037	5.020	4.997

in each set gives a smaller range with smaller increments ($t/r = 0.1$ to 0.2 and $\mu = 0.14$ to 0.34). The determination of a value for K_1 from the tables is done in a similar manner to the method used for Poisson's ratio in Table A1.1.

NOTE A1.5—The constant 37.6991 in the equation is from the Glandus reference and is the numerical value of 12π .

A1.5.4 Dynamic Shear Modulus (G)

A1.5.4.1 The shear modulus is determined from the calcu-

lated Young's modulus value and the Poisson ratio.

$$G = E/[2(1 + \mu)] \quad (A1.5)$$

where:

G = shear modulus (Pa)

E = Young's modulus (Pa) calculated in section A1.5.3

μ = Poisson's ratio determined in section A1.5.2

TABLE A1.3 a K_2 Values (as a function of t/r and μ) [9]

t/r	0.000	0.050	0.100	0.150	0.200	0.250	0.300	0.350	0.400	0.450	0.500
μ						K_2 Value					
0.000	8.240	8.226	8.151	8.027	7.863	7.670	7.455	7.227	6.991	6.754	6.520
0.050	8.378	8.339	8.252	8.124	7.963	7.777	7.570	7.350	7.120	6.885	6.649
0.100	8.511	8.459	8.364	8.233	8.071	7.885	7.679	7.459	7.228	6.991	6.751
0.150	8.640	8.584	8.485	8.349	8.182	7.990	7.779	7.553	7.316	7.074	6.830
0.200	8.764	8.712	8.611	8.469	8.294	8.092	7.871	7.635	7.390	7.141	6.889
0.250	8.884	8.840	8.738	8.589	8.403	8.189	7.954	7.706	7.450	7.191	6.931
0.300	9.000	8.962	8.860	8.705	8.508	8.280	8.030	7.767	7.497	7.226	6.960
0.350	9.111	9.081	8.977	8.814	8.605	8.363	8.098	7.819	7.535	7.253	6.979
0.400	9.219	9.193	9.085	8.913	8.692	8.436	8.157	7.865	7.569	7.276	6.991
0.450	9.321	9.292	9.178	8.997	8.766	8.499	8.208	7.905	7.598	7.295	7.001
0.500	9.420	9.376	9.252	9.063	8.824	8.550	8.252	7.940	7.625	7.313	7.010

TABLE A1.3 b K_2 Values (as a function of t/r and μ) [9]

t/r	0.100	0.110	0.120	0.130	0.140	0.150	0.160	0.170	0.180	0.190	0.200
μ						K_2 Value					
0.14	8.460	8.443	8.411	8.385	8.355	8.326	8.297	8.262	8.234	8.202	8.160
0.16	8.510	8.493	8.460	8.433	8.403	8.373	8.343	8.308	8.279	8.248	8.205
0.18	8.560	8.542	8.509	8.482	8.451	8.421	8.391	8.356	8.327	8.294	8.249
0.2	8.611	8.586	8.559	8.530	8.500	8.469	8.437	8.403	8.368	8.331	8.294
0.22	8.662	8.646	8.613	8.582	8.548	8.517	8.487	8.454	8.425	8.390	8.338
0.24	8.712	8.694	8.660	8.630	8.597	8.565	8.534	8.498	8.467	8.432	8.382
0.26	8.762	8.743	8.708	8.678	8.645	8.612	8.580	8.542	8.510	8.474	8.425
0.28	8.811	8.791	8.755	8.726	8.692	8.659	8.625	8.585	8.551	8.515	8.467
0.3	8.860	8.833	8.804	8.772	8.739	8.705	8.668	8.630	8.591	8.550	8.508
0.32	8.907	8.885	8.848	8.818	8.784	8.750	8.716	8.675	8.640	8.601	8.548
0.34	8.954	8.932	8.894	8.863	8.827	8.793	8.758	8.717	8.681	8.641	8.586

REFERENCES

- (1) Spinner, S., and Tefft, W. E., "A Method for Determining Mechanical Resonance Frequencies and for Calculating Elastic Moduli from These Frequencies," *Proceedings*, ASTM, 1961, pp. 1221–1238.
- (2) Spinner, S., Reichard, T. W., and Tefft, W. E., "A Comparison of Experimental and Theoretical Relations Between Young's Modulus and the Flexural and Longitudinal Resonance Frequencies of Uniform Bars," *Journal of Research of the National Bureau of Standards—A. Physics and Chemistry*, Vol 64A, No. 2, March–April, 1960.
- (3) Spinner, S., and Tefft, W. E., "A Method for Determining Mechanical Resonance Frequencies and for Calculating Elastic Moduli from These Frequencies," *Proceedings*, ASTM, 1961, pp. 1221–1238.
- (4) Pickett, G., "Equations for Computing Elastic Constants from Flexural and Torsional Resonant Frequencies of Vibration of Prisms and Cylinders," *Proceedings*, ASTM, Vol 45, 1945, pp. 846–865.
- (5) Shear modulus correction taken from Spinner, S., and Valore, R. C., "Comparisons Between the Shear Modulus and Torsional Resonance Frequencies for Bars and Rectangular Cross Sections," *Journal of Research*, NIST, JNBA, Vol 60, 1958, RP2861, p. 459.
- (6) Smith, John S., Wyrick, Michael D., and Poole, Jon M., "An Evaluation of Three Techniques for Determining the Young's Modulus of Mechanically Alloyed Materials," *Dynamic Elastic Modulus Measurement in Materials*, ASTM STP 1045, Alan Wolfenden, ed., ASTM, Philadelphia, PA, 1990.
- (7) Colwell, R. C., and Hardy, H. C., "The Frequencies and Nodal Systems of Circular Plates," *Phil. Mag. S. 7*, Vol 24, No. 165, 1937, pp. 1041–1055.
- (8) Martincek, G., "The Determination of Poisson's Ratio and the Dynamic Modulus of Elasticity from the Frequencies of Natural Vibration in Thick Circular Plates," *Journal of J. Sound Vibration*, Vol. 2, No. 2, 1965, pp. 116–127.
- (9) Glandus, J. C., "Rupture Fragile et Résistance aux Chocs Thermiques de Céramiques a Usages Mécaniques," Thesis, University of Limoges, France, 1981.

The American Society for Testing and Materials takes no position respecting the validity of any patent rights asserted in connection with any item mentioned in this standard. Users of this standard are expressly advised that determination of the validity of any such patent rights, and the risk of infringement of such rights, are entirely their own responsibility.

This standard is subject to revision at any time by the responsible technical committee and must be reviewed every five years and if not revised, either reapproved or withdrawn. Your comments are invited either for revision of this standard or for additional standards and should be addressed to ASTM Headquarters. Your comments will receive careful consideration at a meeting of the responsible technical committee, which you may attend. If you feel that your comments have not received a fair hearing you should make your views known to the ASTM Committee on Standards, at the address shown below.

This standard is copyrighted by ASTM, 100 Barr Harbor Drive, PO Box C700, West Conshohocken, PA 19428-2959, United States. Individual reprints (single or multiple copies) of this standard may be obtained by contacting ASTM at the above address or at 610-832-9585 (phone), 610-832-9555 (fax), or service@astm.org (e-mail); or through the ASTM website (www.astm.org).