



Standard Practice for Compression Tests of Metallic Materials at Elevated Temperatures with Conventional or Rapid Heating Rates and Strain Rates¹

This standard is issued under the fixed designation E 209; the number immediately following the designation indicates the year of original adoption or, in the case of revision, the year of last revision. A number in parentheses indicates the year of last reapproval. A superscript epsilon (ϵ) indicates an editorial change since the last revision or reapproval.

1. Scope

1.1 this practice covers compression test in which the specimen is heated to a constant and uniform temperature and held at temperature while an axial force is applied at a controlled rate of strain.

1.2 This practice covers compression tests in which the specimen is heated to a constant and uniform temperature and held at that temperature while it is loaded at a controlled rate of strain.

NOTE 1—In metals with extremely high elastic limit or low modulus of elasticity it is conceivable that 1.5 percent total strain under load could be reached before the 0.2 percent-offset yield strength is reached. In this event the 0.2 percent-offset yield strength will be the end point of the test unless rupture occurs before that point.

NOTE 2—For acceptable compression tests it is imperative that the specimens not buckle before the end point is reached. For this reason the equipment and procedures, as discussed in this recommended practice, must be designed to maintain uniform loading and axial alignment.

1.3 Preferred conditions of testing are recommended so that data from different sources conducting the tests will be comparable.

1.4 The values stated in inch-pound units are to be regarded as the standard.

1.5 *This standard does not purport to address all of the safety concerns, if any, associated with its use. It is the responsibility of the user of this standard to establish appropriate safety and health practices and determine the applicability of regulatory limitations prior to use.*

2. Referenced Documents

2.1 ASTM Standards:

- E 4 Practices for Force Verification of Testing Machines²
- E 9 Test Methods of Compression Testing of Metallic Materials at Room Temperature²
- E 21 Test Methods for Elevated Temperature Tension Tests

¹ This practice is under the jurisdiction of ASTM Committee E-28 on Mechanical Testing and is the direct responsibility of Subcommittee E28.10 on Effect of Elevated Temperature on Properties.

Current edition approved May 10, 2000. Originally published as E 209–1963. Last previous edition, E209–65(93).

² *Annual Book of ASTM Standards*, Vol 03.01.

of Metallic Materials²

E 83 Practice for Verification and Classification of Extensometers²

3. Apparatus

3.1 *Testing Machines*—Machines used for compression testing shall conform to the requirements of Practices E 4.

3.2 *Bearing Blocks and Loading Adapters*—Load both ends of the compression specimens through bearing blocks or through pin-type adapters that are part of the compression-testing assembly. Bearing blocks may be designed with flat bearing faces for sheet- or bar-type specimens. Sheet specimens may also be loaded through pin-type adapters that are clamped rigidly to the grip sections of specimens designed for these adapters (**1**).³ The main requirement is that the method of applying the force be consistent with maintaining axial alignment and uniform loading on the specimen throughout the test. When bearing blocks with flat faces are used, the load-bearing surfaces should be smooth and parallel within very close limits. The tolerance for parallelism for these surfaces should be equal to or closer than that specified for the loaded ends of the specimens. The design of the equipment should provide adequate rigidity so that parallelism is maintained during heating and loading. The bearing blocks or pin-type adapters should be made of a material that is sufficiently hard at the testing temperature to resist plastic indentation at maximum force. They should also be of a material or coated with a material that is sufficiently oxidation resistant at the maximum testing temperature to prevent the formation of an oxide coating that would cause misalignment. In any compression test it is important that the specimen be carefully centered with respect to the bearing blocks, which in turn should be centered with respect to the testing machine heads.

NOTE 3—Bearing blocks with straight cylindrical or threaded holes depending on specimen design may be used for bar-type specimens providing the apparatus qualifies in accordance with Section 9.

NOTE 4—Bearing blocks of an adjustable type to provide parallel loading surfaces are discussed in Test Methods E 9. Bearing blocks with a spherical seat for the upper block are also shown.

³ Boldface numbers in parentheses refer to references at the end of this practice.

3.3 Subpresses—A subpress or other alignment device is necessary in order to maintain suitable alignment when testing specimens that are not laterally supported, unless the testing machine has been designed specifically for axial alignment and uniform application of force in elevated-temperature compression testing. A subpress for room-temperature testing is shown in Test Methods E 9. For elevated-temperature compression testing, the subpress must accommodate the heating and loading devices and the temperature-sensing elements. The design of the subpress is largely dependent on the size and strength of the specimens, the temperatures to be used, the environment, and other factors. It must be designed so the ram does not jam or tilt the frame as a result of heating or application of force. If the bearing faces of the subpress, the opposite faces of both bearing blocks, and the ends of the specimen are respectively plane and parallel within very close limits, it is unnecessary to use adjustable or spherical seats. In any case, the specimen should be properly centered in the subpress.

3.4 Compression Testing Jigs—When testing sheet material, buckling of the specimen during application of compressive forces must be prevented. This may be accomplished by using a jig containing side-support plates that bear against the faces of the specimen. The jig must afford a suitable combination of lateral-support pressure and spring constant to prevent buckling without interfering with axial deformation of the specimen (1). Although suitable combinations vary somewhat with variations in specimen material and thickness, testing temperature, and accuracy of alignment, acceptable results can be obtained with rather wide ranges of lateral-support pressure and spring constant for any given test conditions. Generally, the higher the spring constant of the jig, the lower the lateral-support pressure that is required. Proper adjustment of these test variables may be established in preliminary verification tests for the equipment (Section 9).

3.4.1 This practice does not intend to designate specific compression jigs for testing sheet metals, but merely to provide a few illustrations and references to jigs that have been used successfully. Many other jigs are acceptable provided they prevent buckling and pass the qualification tests set forth in Section 9. Satisfactory results have been obtained in room-temperature testing using the jigs illustrated in Test Methods E 9. These jigs usually require that the specimen be lubricated to permit normal compression on loading. For elevated-temperature testing, modified jigs that accommodate the heating and strain-measuring equipment as well as the temperature-sensing elements must be used. A number of compression-testing jigs have been evaluated specifically for performance in elevated-temperature tests (2, 3). The preferred type depends on the material, its thickness, and the temperatures involved. For moderately elevated temperatures, one of the room-temperature designs may be used in an oven in which the air is circulated to provide uniform heating. One design for side-support plates that has been found satisfactory for use at temperatures up to 1000°F (538°C) when lubricated with graphite is shown in Fig. 1(a) (4). Longitudinal grooves are cut in each plate with the grooves offset across the thickness of the specimen. These plates are made of titanium carbide. A type of

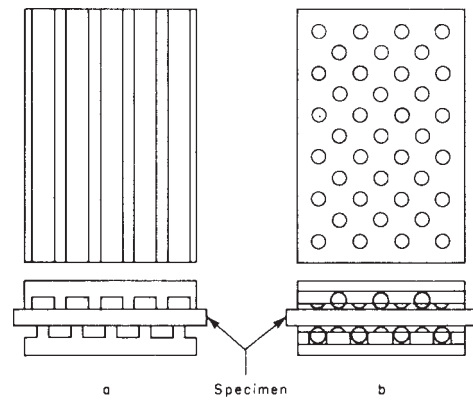

FIG. 1 Specimen Side Support Plates (Ref 4)

side-support plate that has been used in compression jigs to 1800°F (982°C) is shown in Fig. 1(b) (4). This is an assembly of small titanium carbide balls backed up by a titanium carbide plate. The balls protrude through holes in the front retaining plate. The holes for the balls are large enough to allow rotation and translation of each ball while at the same time retaining the balls in the plate assembly. The spacing of the balls, which is normally about 1/8 in. (3.2 mm), determines the minimum specimen thickness that can be tested without buckling between the balls. Rational values of the ball spacing can be obtained from calculations based upon the plastic buckling of simply supported plates where the plate width can be taken as the ball spacing. Another type of jig has a number of leaf-spring supports on each side of the specimen (3, 5). This design is limited to a temperature range in which the metal leaf-spring elements can support the specimen satisfactorily. Jigs for use with specimens that are heated by self resistance are discussed in Ref 1, 6 and 7, which also provide quantitative information on the effects of lubrication, lateral-support pressure, spring constant, and misalignment.

3.4.2 The side-support plates are assembled in a frame that is part of the jig. A typical frame and jig assembly is shown in Fig. 2. A furnace is placed around the jig after the specimen and extensometer are assembled in the jig. The holes in the support blocks are for auxiliary cartridge-type heaters.

4. Heating Apparatus

4.1 The apparatus and method for heating the specimens are not specified, but in present practice the following are mainly used.

- 4.1.1 The resistance of the specimen gage length to the passage of an electric current,
- 4.1.2 Resistance heating supplemented by radiant heating,
- 4.1.3 Radiant heating,
- 4.1.4 Induction heating, or
- 4.1.5 Convection heating with circulating-air furnace.

4.2 The apparatus must be suitable for heating the specimen under the conditions specified in Section 5.

5. Test Specimen

5.1 The size and shape of the test specimen should be based on three requirements as follows:

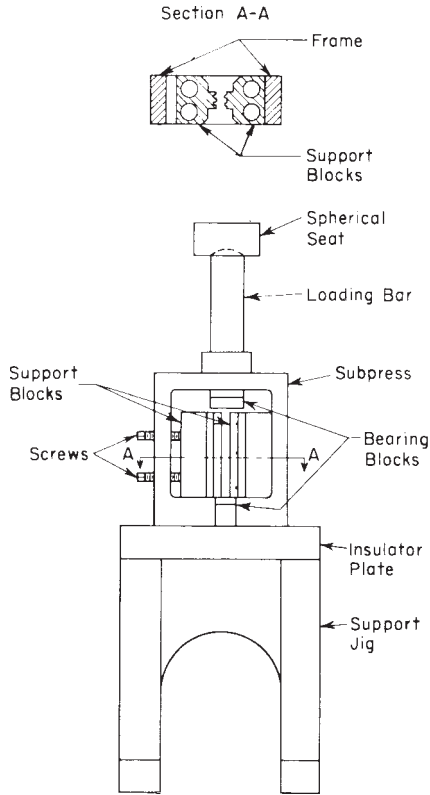

FIG. 2 Typical Compression Testing Jig for Sheet Specimens Mounted on Support Jig (Ref 3)

5.1.1 The specimen should be representative of the material being investigated and should be taken from the material produced in the form and condition in which it will be used,

5.1.2 The specimen should be adapted to meet the requirements on temperature control and rates of heating and straining, and

5.1.3 The specimen should be conducive to the maintenance of axial alignment uniform application of force, and freedom from buckling when loaded to the end point in the apparatus used.

5.2 The specimens are divided into two general classifications: those with rectangular cross sections and those with round cross sections. The dimensions of the specimens are optional. The specimen must be long enough to be compressed to the required deformation without interference from a supporting jig but not long enough to permit buckling where it is unsupported. The end allowance (dimension between the gage points and the adjacent end of the uniform section) should be a minimum of one half the width of rectangular specimens or one half the diameter of round specimens. Typical acceptable specimens are illustrated in Fig. 3 and Fig. 4.

5.3 When the dimensions of the test material permit, round specimens should be used. Round specimens should be designed to be free from buckling up to the end point of the test without lateral support. Rectangular specimens up to 0.250 in. (6.35 mm) thick normally require lateral support; with greater thicknesses lateral support may not be required in well-aligned equipment. The methods covered by this specification are normally satisfactory for testing sheet specimens down to 0.020 in. (0.51 mm) thick. With smaller thicknesses inaccuracies resulting from buckling and nonuniform straining tend to increase; consequently, extra care in the design, construction, and use of the test equipment is required to obtain valid results for specimens in this thickness range. All compression specimens should be examined after they are tested; any evidence of buckling invalidates the results for that specimen.

5.4 The width and thickness of rectangular specimens and diameter of round specimens at any point in the gage length should not vary from the average by more than 0.001 in. (0.025 mm) for dimensions up to 1 in. (25.4 mm) or by more than 0.1 percent for dimensions above 1 in.

5.5 The ends of end-loaded specimens should be parallel within 0.00025 in. (0.0064 mm) for widths, thicknesses, and diameters up to 1/2 in. (12.7 mm) and within 0.05 percent for widths, thicknesses, and diameters above 1/2 in. The ends of end-loaded specimens should be perpendicular to the sides within 1/4 of a degree. All machined surfaces should have an average surface finish of 63 μ in. or better. Rectangular

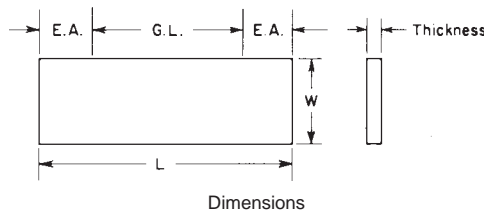

Dimensions

	Specimen 1	Specimen 2	Specimen 3
G.L.—Gage Length, in. (mm)	1.000 ± 0.005 (25.4 ± 0.13)	2.000 ± 0.005 (50.8 ± 0.13)	2.000 ± 0.005 (50.8 ± 0.13)
L—Uniform Section, in. (mm)	2.500 ± 0.005 (63.5 ± 0.13)	3.000 ± 0.005 (76.2 ± 0.13)	2.50 min (63.5)
W—Width, in. (mm)	0.625 ± 0.010 (15.9 ± 0.25)	1.000 ± 0.010 (25.4 ± 0.25)	0.500 ± 0.010 (12.7 ± 0.25)
E.A.—End Allowance, in. (mm)	0.75 (19)	0.50 (12.7)	0.25 min (6.35)

FIG. 3 Dimensions of Typical Rectangular Specimens

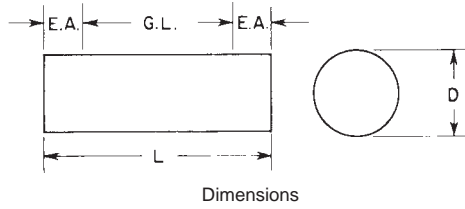

	Specimen 1	Specimen 2	Specimen 3
G.L.—Gage Length, in.	1.000 ± 0.005 (25.4 ± 0.13)	2.000 ± 0.005 (50.8 ± 0.13)	1.000 ± 0.005 (25.4 ± 0.13)
L—Uniform Section, in.	1.500 ± 0.005 (38.1 ± 0.13)	3.375 ± 0.05 (85.8 ± 1.27)	1.500 ± 0.005 (38.1 ± 0.13)
D—Diameter, in.	0.500 ± 0.010 (12.7 ± 0.25)	1.125 ± 0.010 (28.6 ± 0.25)	0.375 ± 0.010 (9.5 ± 0.25)
E.A.—End Allowance, in.	0.25 (6.35)	0.69 (17.5)	0.25 (6.35)

NOTE 1—Specimen 3, because of its smaller diameter, is especially suitable for tests in which rapid heating is desired.

FIG. 4 Dimensions of Typical Round Specimens

specimens should have a width of material, equal to at least the thickness of the specimen, machined from all sheared or stamped edges.

5.6 Shouldered specimens may be used in lieu of specimens with uniform width or diameter, provided the method of applying force is consistent with requirements of axial alignment, uniform application of force, and freedom from buckling.

5.7 The surfaces of the rectangular specimens in contact with the supporting jig should be lubricated to reduce friction. The lubricant should have negligible reaction with the surface of the specimen for the test temperature and time chosen and should retain its lubricating properties for the duration of the test. Molybdenum disulfide and graphite are examples of lubricants that are used.

5.8 Specimen dimensions above 0.100 (2.54 mm) in. should be measured to the nearest 0.001 in. (0.025 mm) or less; dimensions under 0.100 in. should be measured to the nearest 1 percent or less. The average cross-sectional area of the gage length should be used for calculation of stress.

6. Temperature Control

6.1 Conventional Heating—When a conventional-heating rate is desired, variations in indicated temperature within the gage length of the specimen should not exceed the following limits during a test:

Test Temperature	Allowable Variation, deg F (deg C), plus and minus
Up to and including 1800°F (982°C)	5 (3)
Over 1800°F (982°C) up to and including 2800°F (1538°C)	10 (5.5)
Over 2800°F (1538°C) up to and including 3500°F (1927°C)	20 (11)
Over 3500°F (1927°C)	35 (19.5)

The time of heating and holding prior to the start of the stressing should be governed by the time necessary to ensure that the temperatures can be maintained as specified. If compression tests are being made as the counterpart to tension test under Practice E 21, the heating time and holding time in

both types of tests should be the same. The heating and holding time actually used should be reported.

6.2 Rapid Heating—When a rapid heating rate is desired, the preferred conditions for heating the gage length of the specimen are as follows:

6.2.1 Sixty seconds or less to heat to the indicated nominal test temperature, and

6.2.2 Holding time at the indicated nominal test temperature before applying the force equal to the heating time.

6.2.3 The indicated control temperature of the specimen should not vary more than ±10°F (5.5°C) from the nominal test temperature up to and including 1000°F (538°C) and not more than ±1.0 % of the nominal test temperature above 1000°F. The uniformity of temperature within the specimen gage length should be within + 10°F and – 20°F (11°C) of the nominal test temperature up to and including 1000°F and within + 1.0 and – 2.0 % of the nominal test temperature above 1000°F.

NOTE 5—It is recognized that true temperatures will vary more than the indicated temperatures. The permissible indicated temperature variations specified in 6.1 and 6.2 are not to be construed as minimizing the importance of good pyrometry practice and accurate temperature control in these tests. All laboratories are obligated to keep both indicated and true temperature variations as small as practicable. In view of the extreme dependency of strength of materials on temperature, close temperature control is necessary. The limits prescribed represent ranges that are common practice. For further information on pyrometric practices reference should be made to the “Panel Discussion on Pyrometric Practices.”⁴

6.3 In rapid-heating tests a maximum overshoot in the indicated temperature during the heating and holding period of 20°F or 2.0 % of the nominal test temperature, whichever is greater, is allowed for a time not exceeding 30 s. The overshoot limitation permits a larger temperature variation for a 30-s period prior to testing than permitted for conventional-heating tests, for which no overshoot in temperature beyond the allowable variations in 6.1 is allowed.

⁴ Panel Discussion on Pyrometric Practices, ASTM STP 178, Am. Soc. Testing Mats. (1955).

6.4 Conditions of heating to and holding at nominal test temperature as specified in 6.1 through 6.3 are preferred to facilitate comparison of data between laboratories. The thermal history given material during testing should be accurately reported, particularly when equipment limitations or simulated service testing cause deviations from the requirements of this practice.

6.5 The “indicated nominal temperature” and “indicated temperatures” as used in the above paragraphs are temperatures indicated by the temperature-measuring instrument with good pyrometric practice.

7. Temperature Measurement

7.1 Observe the following minimum precautions when thermocouples are used for temperature measurements:

7.1.1 Use small-diameter wires where heat conduction along the couples might cause excessive heat loss as, for example, where self-resistant heating is employed. In this method 36-gage wire has been found satisfactory.

7.1.2 Keep the hot junction of the thermocouple in direct contact with the test section of the specimen. In the case of rapid-heating tests, fast response is required, and the preferred method of attaching the thermocouples to the gage section is capacitance welding. The proper power settings should be used in order to minimize any undesirable metallurgical changes at the attachment points.

7.1.3 Where radiant means of heating are used, shield the thermocouple hot junction from direct radiation by the heating elements in order to prevent erroneous high readings.

7.1.4 Where electrical self-resistance heating is used, exercise care to ensure that there is no superimposed voltage pickup by the couples.

7.1.5 Use certified or otherwise calibrated thermocouple wires for all tests. The calibration of a thermocouple may change with age or after exposure to extreme temperatures. Also, noble-metal thermocouples are easily contaminated. Make frequent checks to ensure thermocouple accuracy. In the case of base-metal thermocouples, clipping back the heated portion is generally more convenient than recalibration.

7.2 Methods other than thermocouples may be used for measuring temperature provided it can be demonstrated that they meet the requirements of Section 6. Temperature measurements with optical and radiation methods, for example, must be corrected for deviations in specimen emissivity from 1.0 in determining the indicated specimen temperature.

7.3 All equipment used for measuring, controlling and recording temperatures, should be verified and if necessary calibrated against a standard periodically. Lead-wire error should also be checked with the load wires in place as they are normally used.

8. Strain Rate During Test

8.1 Apply the force to the specimen to obtain uniform rates of straining as specified in 8.2 and 8.3. Start the application of the load at the end of the holding time at the specified test temperature.

8.2 *Conventional Strain Rate*—When a normal rate of straining is desired after conventional or rapid heating, use a

strain rate of 0.005 ± 0.002 in./in. (0.5 ± 0.2 percent)/min from the start of loading to the end point of the test.

8.3 *Rapid Strain Rate*—When a rapid strain rate is desired after conventional or rapid heating, use a strain rate of 0.5 ± 0.2 in./in. (50 ± 20 percent)/min from the start of loading to the end point of the test. Since some ordinary test equipment is not designed for rapid strain rates, precautions should be taken to ensure that equipment used at rapid strain rates is accurate at these rates.

8.4 When possible, use strain-pacing equipment, an automatic feed-back system, or other equivalent means to obtain a constant strain rate. If such equipment is not available, maintain a constant crosshead speed to obtain the desired average strain rate from the start of loading to the end point of the test. The average strain rate can be determined from a time-interval-marked force-strain record, a time-strain graph, or from a stop-watch measurement of time from the start of loading to the end point of the test. It should be recognized that the use of machines with constant rate of crosshead movement does not ensure constant strain rate throughout a test.

8.5 The preferred rates of straining are those specified in 8.2 and 8.3 to facilitate comparison of data between laboratories. It is further recommended that, when a faster rate of straining is desired, the rate be 5.0 ± 2.0 in./in. (500 ± 200 percent)/min. It is recommended that other rates of straining be confined to those cases where special application of the data or material properties requires intermediate rates. Report the strain rate used with test results.

9. Strain Measurement

9.1 Record the stress-strain diagram up to the end point of the test; prolonging the test beyond the end point defined in Section 1 is optional.

9.2 Use an extensometer of Class B-2 or better as described in Practice E 83, Verification and Classification of Extensometers.⁴

NOTE 6—A discussion of the importance of strain-measuring systems used with compression jigs is described in Ref. 2.

9.3 Attach the extensometer directly to the gage length of the specimen. No restrictions are placed on the method of attachment except that it should not affect the properties, and the extensometer should remain fixed to the gage length without any slippage. Attachment of the extensometer to any other part of the specimen or apparatus is not recommended, but when such attachment is necessary, it must be accompanied by proof that adequate corrections were used to compensate for the strain that occurred outside the gage length, and the method of attachment and location should be shown.

9.4 The strain should be measured as opposite sides of the specimen and averaged to give center-line strain.

9.5 Verify the extensometer for sensitivity and accuracy in accordance with Practice E 83. The extensometer should fulfill the requirements for the class of extensometer specified in 9.2 at room temperature. Pending the availability of standard methods of calibration at elevated temperatures, exercise care to be sure that the extensometer maintains calibration as the temperature of the specimen is increased to the test temperature and during the test. This requires that those parts of the

extensometer that would be affected by the heat of the specimen be shielded from temperature changes during the test.

9.6 When rapid strain rates are used during a test, the extensometer must be verified to have a rate of response adequate to measure strain to the limits required in Section 7.

NOTE 7—The forces applied by the extensometer to the specimen may introduce errors in the stress-strain data for small specimens or for tests at very high temperatures where the strength of the specimens is low. In such tests, counterbalancing or other mechanical arrangements should be used to minimize the forces and bending moments introduced by the extensometer. The use of calculated corrections for the force of the extensometer is the least preferred method for correcting this type of error. For tests where the load of the extensometer is significant, the report of the test results should show the method of correction used.

10. Qualification of Test Apparatus

10.1 The complete compression-test system consisting of jig, strain instrument, and recorders should be qualified, in accordance with 10.2-10.5, by each of the personnel assigned to conduct test programs.

10.2 At room temperature, conduct tests to the proportional limit on five different specimens of 2024-T3 aluminum alloy to establish the elastic modulus during both the application and removal of forces. If each of the modulus values so determined falls within 10.7×10^6 psi (7.38×10^4 MPa) ± 5 percent, the compression-testing technique qualifies for room-temperature operation.

10.3 At elevated temperatures starting at 400°F (204°C) and in 400°F (220°C) increments to the maximum use temperature, determine the modulus of elasticity in tension for three specimens at each temperature both loading and unloading using an alloy with distinct elastic properties at each temperature. Conduct identical tests in compression using the compression test technique. If the compression moduli from consecutive specimens fall within ± 5 % of the average tension modulus, the technique qualifies for operation to the maximum temperature successfully reached in this procedure.

10.4 The qualification procedure should be carried out on the thinnest rectangular specimens or smallest diameter round specimens to be tested in the system being qualified.

10.5 If the compression-test technique qualifies at room temperature and at each test temperature in 400°F increments to the maximum use temperature, it shall be considered satisfactory for tests at any intermediate temperature in the room-temperature to the maximum-use-temperature range, provided that all conditions are maintained constant thereafter.

11. Report

11.1 Report the following minimum information for each test:

11.1.1 Indicated test temperature, heating rate, holding time at test temperature, and strain rate, and

11.1.2 The 0.2 percent-offset compressive yield strength as determined from the stress-strain curve.

11.2 Report the following additional information when needed for design or other purposes:

11.2.1 Compressive modulus of elasticity,

11.2.2 Compressive yield strength at other amounts of offset up to the end point of the test,

11.2.3 Copy of stress-strain curve,

11.2.4 Drop-of-beam yield point if such a yield point occurs,

11.2.5 Tangent modulus as a function of stress, and

11.2.6 Secant modulus as a function of stress.

11.3 The following information essential to the interpretation of the results should also be given:

11.3.1 Description of the material tested and the orientation of the specimen with respect to the test material,

11.3.2 Nominal size and type of specimen used including machining methods and any special techniques to control surface finish,

11.3.3 Type of test apparatus and method of heating, and

11.3.4 Accuracy of apparatus.

11.4 Any deviations from the preferred or specified conditions of testing should be indicated with the results of the tests.

REFERENCES

- (1) Bennett, E. C., and Gerberich, W. W., "Rapid-Rate Compression Testing of Sheet Materials at High Temperatures," *ASTM STP 303*, ASTTA, Am. Soc. Testing Mats., 1961, pp. 33-46.
- (2) Gerard, George, "An Evaluation of Compression-Testing Techniques of Sheet Materials at Elevated Temperatures," *ASTM STP 303*, ASTTA, Am. Soc. Testing Mats., 1961, pp. 3-11.
- (3) Hyler, W. S., "An Evaluation of Compression-Testing Techniques for Determining Elevated-Temperature Properties of Titanium Sheet," *Titanium Metallurgical Laboratory Report No. 43*, June 8, 1956.
- (4) King, J. P., "Compression Testing at Elevated Temperatures," *Metals Engineering Quarterly*, MENQA, Vol 1, No. 3, August, 1961, pp. 30-38.
- (5) Breindel, W. W., Carlson, R. L., and Holden, F. C., "An Evaluation of a System for the Compression Testing of Sheet Materials at Elevated Temperatures," *ASTM STP 303*, ASTTA, Am. Soc. Testing Mats., 1961, pp. 77-84.
- (6) Fenn, Jr., R. W., "Compression Testing Sheet Magnesium Utilizing Rapid Heating," *Proceedings*, ASTEA, Am. Soc. Testing Mats., Vol 60, 1960, p. 940.
- (7) Fenn, Jr., R. W., "Evaluation of Test Variables in the Determination of Elevated-Temperature Compressive Yield Strength of Magnesium Alloy Sheet," *ASTM STP 303*, ASTTA, Am. Soc. Testing Mats., 1961, pp. 48-59.



E 209

ASTM International takes no position respecting the validity of any patent rights asserted in connection with any item mentioned in this standard. Users of this standard are expressly advised that determination of the validity of any such patent rights, and the risk of infringement of such rights, are entirely their own responsibility.

This standard is subject to revision at any time by the responsible technical committee and must be reviewed every five years and if not revised, either reapproved or withdrawn. Your comments are invited either for revision of this standard or for additional standards and should be addressed to ASTM International Headquarters. Your comments will receive careful consideration at a meeting of the responsible technical committee, which you may attend. If you feel that your comments have not received a fair hearing you should make your views known to the ASTM Committee on Standards, at the address shown below.

This standard is copyrighted by ASTM International, 100 Barr Harbor Drive, PO Box C700, West Conshohocken, PA 19428-2959, United States. Individual reprints (single or multiple copies) of this standard may be obtained by contacting ASTM at the above address or at 610-832-9585 (phone), 610-832-9555 (fax), or service@astm.org (e-mail); or through the ASTM website (www.astm.org).