



Standard Test Methods for Notched Bar Impact Testing of Metallic Materials¹

This standard is issued under the fixed designation E 23; the number immediately following the designation indicates the year of original adoption or, in the case of revision, the year of last revision. A number in parentheses indicates the year of last reapproval. A superscript epsilon (ε) indicates an editorial change since the last revision or reapproval.

This standard has been approved for use by agencies of the Department of Defense.

1. Scope

1.1 These test methods describe notched-bar impact testing of metallic materials by the Charpy (simple-beam) test and the Izod (cantilever-beam) test. They give the requirements for: test specimens, test procedures, test reports, test machines (see Annex A1) verifying Charpy impact machines (see Annex A2), optional test specimen configurations (see Annex A3), pre-cracking Charpy V-notch specimens (see Annex A4), designation of test specimen orientation (see Annex A5), and determining the percent of shear fracture on the surface of broken impact specimens (see Annex A6). In addition, information is provided on the significance of notched-bar impact testing (see Appendix X1), methods of measuring the center of strike (see Appendix X2), and the availability of Charpy V-notch verification specimens (see Appendix X3).

1.2 These test methods do not address the problems associated with impact testing at temperatures below $-196\text{ }^{\circ}\text{C}$ ($-320\text{ }^{\circ}\text{F}$, $77\text{ }^{\circ}\text{K}$).

1.3 The values stated in SI units are to be regarded as the standard. Inch-pound units are provided for information only.

1.4 *This standard does not purport to address all of the safety concerns, if any, associated with its use. It is the responsibility of the user of this standard to establish appropriate safety and health practices and determine the applicability of regulatory limitations prior to use.* Specific precautionary statements are given in Section 5.

2. Referenced Documents

2.1 ASTM Standards:

E 177 Practice for Use of the Terms Precision and Bias in ASTM Test Methods²

E 399 Test Method for Plane-Strain Fracture Toughness of Metallic Materials³

E 604 Test Method for Dynamic Tear Energy of Metallic Materials³

E 691 Practice for Conducting an Interlaboratory Study to Determine the Precision of a Test Method²

¹ These test methods are under the jurisdiction of ASTM Committee E-28 on Mechanical Testing and are the direct responsibility of Subcommittee E28-07 on impact testing.

Current edition approved May 10, 2000. Published August 2000. Originally published as E 23 – 33 T. Last previous edition E 23 – 98.

² *Annual Book of ASTM Standards*, Vol 14.02.

³ *Annual Book of ASTM Standards*, Vol 03.01.

E 1271 Practice for Qualifying Charpy Verification Specimens of Heat-treated Steel³

E 1313 Guide for Recommended Formats for Data Records Used in Computerization of Mechanical Test Data for Metals⁴

3. Summary of Test Method

3.1 The essential features of an impact test are: a suitable specimen (specimens of several different types are recognized), an anvil or support on which the test specimen is placed to receive the blow of the moving mass, a moving mass that has sufficient energy to break the specimen placed in its path, and a device for measuring the energy absorbed by the broken specimen.

4. Significance and Use

4.1 These test methods of impact testing relate specifically to the behavior of metal when subjected to a single application of a force resulting in multi-axial stresses associated with a notch, coupled with high rates of loading and in some cases with high or low temperatures. For some materials and temperatures the results of impact tests on notched specimens, when correlated with service experience, have been found to predict the likelihood of brittle fracture accurately. Further information on significance appears in Appendix X1.

5. Precautions in Operation of Machine

5.1 Safety precautions should be taken to protect personnel from the swinging pendulum, flying broken specimens, and hazards associated with specimen warming and cooling media.

6. Apparatus

6.1 General Requirements:

6.1.1 The testing machine shall be a pendulum type of rigid construction.

6.1.2 The testing machine shall be designed and built to conform with the requirements given in Annex A1.

6.2 Inspection and Verification

6.2.1 Inspection procedures to verify impact machines directly are provided in A2.2 and A2.3. The items listed in A2.2 must be inspected annually.

6.2.2 The procedures to verify Charpy V-notch machines

⁴ *Annual Book of ASTM Standards*, Vol 14.01.

indirectly, using verification specimens, are given in A2.4. Charpy impact machines must be verified annually.

7. Test Specimens

7.1 Configuration and Orientation:

7.1.1 Specimens shall be taken from the material as specified by the applicable specification. Specimen orientation should be designated according to the terminology given in Annex A5.

7.1.2 The type of specimen chosen depends largely upon the characteristics of the material to be tested. A given specimen may not be equally satisfactory for soft nonferrous metals and hardened steels; therefore, many types of specimens are recognized. In general, sharper and deeper notches are required to distinguish differences in very ductile materials or when using low testing velocities.

7.1.3 The specimens shown in Figs. 1 and 2 are those most widely used and most generally satisfactory. They are particularly suitable for ferrous metals, excepting cast iron.⁵

7.1.4 The specimen commonly found suitable for die-cast alloys is shown in Fig. 3.

7.1.5 The specimens commonly found suitable for powdered metals (P/M) are shown in Figs. 4 and 5. The specimen

surface may be in the as-produced condition or smoothly machined, but polishing has proven generally unnecessary. Unnotched specimens are used with P/M materials. In P/M materials, the impact test results are affected by specimen orientation. Therefore, unless otherwise specified, the position of the specimen in the machine shall be such that the pendulum will strike a surface that is parallel to the compacting direction.

7.1.6 Sub-size and supplementary specimen recommendations are given in Annex A3.

7.2 Specimen Machining:

7.2.1 When heat-treated materials are being evaluated, the specimen shall be finish machined, including notching, after the final heat treatment, unless it can be demonstrated that the impact properties of specimens machined before heat treatment are identical to those machined after heat treatment.

7.2.2 Notches shall be smoothly machined but polishing has proven generally unnecessary. However, since variations in notch dimensions will seriously affect the results of the tests, adhering to the tolerances given in Fig. 1 is necessary (Appendix X1.2 illustrates the effects from varying notch dimensions on Type A specimens). In keyhole specimens, the round hole shall be carefully drilled with a slow feed rate. The slot may be cut by any feasible method, but care must be exercised in cutting the slot to ensure that the surface of the drilled hole opposite the slot is not damaged.

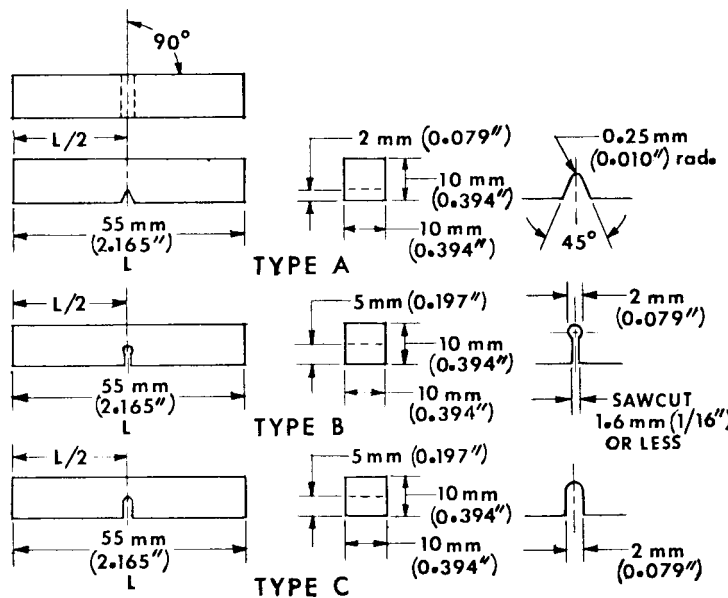

NOTE 1—Permissible variations shall be as follows:

Notch length to edge	90 ± 2°
Adjacent sides shall be at	90° ± 10 min
Cross-section dimensions	± 0.075 mm (± 0.003 in.)
Length of specimen (L)	+0, -2.5 mm (+0, -0.100 in.)
Centering of notch (L/2)	± 1 mm (± 0.039 in.)
Angle of notch	± 1°
Radius of notch	± 0.025 mm (± 0.001 in.)
Notch depth:	
Type A specimen	± 0.025 mm (± 0.001 in.)
Types B and C specimen	± 0.075 mm (± 0.003 in.)
Finish requirements	2 µm (63 µin.) on notched surface and opposite face; 4 µm (125 µin.) on other two surfaces

FIG. 1 Charpy (Simple-Beam) Impact Test Specimens, Types A, B, and C

E 23

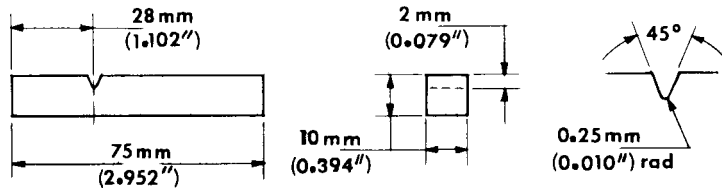

NOTE 1—Permissible variations shall be as follows:

Notch length to edge	90 ± 2°
Cross-section dimensions	±0.025 mm (±0.001 in.)
Length of specimen	+0, -2.5 mm (±0, -0.100 in.)
Angle of notch	±1°
Radius of notch	±0.025 mm (±0.001 in.)
Notch depth	±0.025 mm (±0.001 in.)
Adjacent sides shall be at	90° ± 10 min
Finish requirements	2 μm (63 μin.) on notched surface and opposite face; 4 μm (125 μin.) on other two surfaces

FIG. 2 Izod (Cantilever-Beam) Impact Test Specimen, Type D

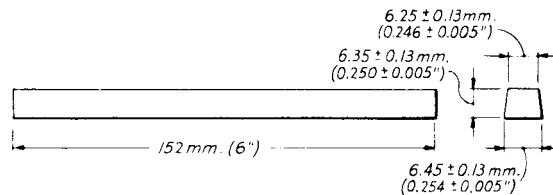

NOTE 1—Two Izod specimens may be cut from this bar.

NOTE 2—Blow shall be struck on narrowest face.

FIG. 3 Izod Impact Test Bar for Die Castings Alloys

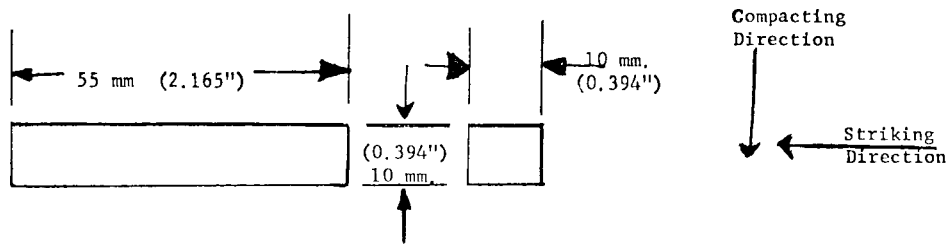

NOTE 1—Permissible variations shall be as follows:

Adjacent sides shall be at	90° ± 10 min
Cross section dimensions	±0.125 mm (0.005 in.)
Length of specimen	+0, -2.5 mm (+0, -0.100 in.)

FIG. 4 Charpy (Simple Beam) Impact Test Specimens for Metal Powder Structural Parts

7.2.3 Identification marks shall only be placed in the following locations on specimens: either of the 10-mm square ends; the side of the specimen that faces up when the specimen is positioned in the anvils (see Note 1); or the side of the specimen opposite the notch. No markings, on any side of the specimen, shall be within 15 mm of the center line of the notch. An electrostatic pencil may be used for identification purposes, but caution must be taken to avoid excessive heat.

NOTE 1—Careful consideration should be given before placing identification marks on the side of the specimen to be placed up when positioned in the anvils. If the test operator is not careful, the specimen may be placed in the machine with the identification marking resting on the specimen supports. Under these circumstances, the absorbed energy value obtained may be unreliable.

8. Procedure

8.1 *Preparation of the Apparatus:*

8.1.1 Perform a routine procedure for checking impact machines at the beginning of each day, each shift, or just prior to testing on a machine used intermittently. It is recommended that the results of these routine checks be kept in a log book for the machine. After the testing machine has been ascertained to comply with Annex A1 and Annex A2, carry out the routine check as follows:

8.1.1.1 Visually examine the striker and anvils for obvious damage and wear.

8.1.1.2 Check the zero position of the machine by using the following procedure: raise the pendulum to the latched position, move the pointer to near the maximum capacity of the range being used, release the pendulum, and read the indicated value. The pointer should indicate zero on machines reading directly in energy. On machines reading in degrees, the reading should correspond to zero on the conversion chart furnished by

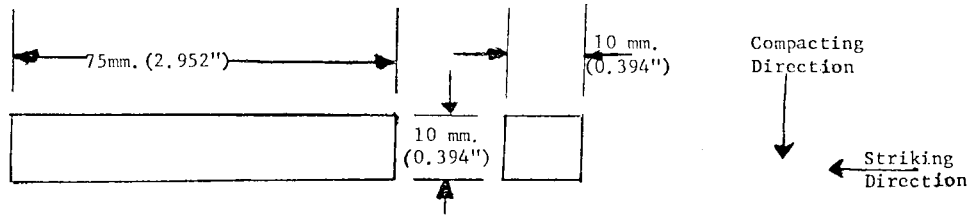

NOTE 1—Permissible variations shall be as follows:

Adjacent sides shall be at	$90^\circ \pm 10 \text{ min.}$
Cross section dimensions	$\pm 0.125 \text{ mm (0.005 in.)}$
Length of specimens	$+0, -2.5 \text{ mm (+0, -0.100 in.)}$

FIG. 5 Izod (Cantilever-Beam) Impact Test Specimen for Metal Powder Structural Parts

the machine manufacturer.

NOTE 2—On machines that do not compensate for windage and friction losses, the pointer will not indicate zero. In this case, the indicated values, when converted to energy, shall be corrected for frictional losses that are assumed to be proportional to the arc of swing.

8.1.1.3 To ensure that friction and windage losses are within allowable tolerances, the following procedure is recommended: raise the pendulum to the latched position, move the pointer to the negative side of zero, release the pendulum and allow it to cycle five times (a forward and a backward swing together count as one swing), prior to the sixth forward swing, set the pointer to between 5 and 10 % of the scale capacity of the dial, after the sixth forward swing (eleven half swings), record the value indicated by the pointer, convert the reading to energy (if necessary), divide it by 11 (half swings), then divide by the maximum scale value being used and multiply it by 100 to get the percent friction. The result, friction and windage loss, shall not exceed 0.4 % of scale range capacity being tested and should not change by more than 5 % of friction measurements previously made on the machine. If the friction and windage loss value does exceed 0.4 % or is significantly different from previous measurements, check the indicating mechanism, the latch height, and the bearings for wear and damage. However, if the machine has not been used recently, let the pendulum swing for 50 to 100 cycles, and repeat the friction test before undertaking repairs to the machine.

8.2 Test Temperature Considerations:

8.2.1 The temperature of testing affects the impact properties of most materials. For materials with a body centered cubic structure, a transition in fracture mode occurs over a temperature range that depends on the chemical composition and microstructure of the material. Test temperatures may be chosen to characterize material behavior at fixed values, or over a range of temperatures to characterize the transition region, lower shelf, or upper shelf behavior, or all of these. The choice of test temperature is the responsibility of the user of this test method and will depend on the specific application.

8.2.2 The temperature of a specimen can change significantly during the interval it is removed from the temperature conditioning environment, transferred to the impact machine, and the fracture event is completed (see Note 5). When using a heating or cooling medium near its boiling point, use data from the references in Note 5 or calibration data with thermocouples to confirm that the specimen is within the stated temperature tolerances when the striker contacts the specimen.

If excessive adiabatic heating is expected, monitor the specimen temperature near the notch during fracture.

8.2.3 Verify temperature-measuring equipment at least every six months. If liquid-in-glass thermometers are used, an initial verification shall be sufficient, however, the device shall be inspected for problems, such as the separation of liquid, at least twice annually.

8.2.4 Hold the specimen at the desired temperature within $\pm 1^\circ\text{C}$ ($\pm 2^\circ\text{F}$) in the temperature conditioning environment (see 8.2.4.1 and 8.2.4.2). Any method of heating or cooling or transferring the specimen to the anvil(s) may be used provided the temperature of the specimen immediately prior to fracture is essentially the same as the holding temperature (see Note 5). The maximum change in the temperature of the specimen allowed for the interval between the temperature conditioning treatment and impact is not specified here, because it is dependent on the material being tested and the application. The user of nontraditional or lesser used temperature conditioning and transfer methods (or sample sizes) shall show that the temperature change for the specimen prior to impact is comparable to or less than the temperature change for a standard size specimen of the same material that has been thermally conditioned in a commonly used medium (oil, air, nitrogen, acetone, methanol), and transferred for impact within 5 seconds (see Note 5). Three temperature conditioning and transfer methods used in the past are: liquid bath thermal conditioning and transfer to the specimen supports with centering tongs; furnace thermal conditioning and robotic transfer to the specimen supports; placement of the specimen on the supports followed by in situ heating and cooling.

8.2.4.1 For liquid bath cooling or heating use a suitable container, which has a grid or another type of specimen positioning fixture. Cover the specimens, when immersed, with at least 25 mm (1 in.) of the liquid, and position so that the notch area is not closer than 25 mm (1 in.) to the sides or bottom of the container, and no part of the specimen is in contact with the container. Place the device used to measure the temperature of the bath in the center of a group of the specimens. Agitate the bath and hold at the desired temperature within $\pm 1^\circ\text{C}$ ($\pm 2^\circ\text{F}$). Thermally condition the specimens for at least 5 min before testing, unless a shorter thermal conditioning time can be shown to be valid by measurements with thermocouples. Leave the mechanism (tongs, for example) used to handle the specimens in the bath for at least 5 min

before testing, and return the mechanism to the bath between tests.

8.2.4.2 When using a gas medium, position the specimens so that the gas circulates around them and hold the gas at the desired temperature within $\pm 1^\circ\text{C}$ ($\pm 2^\circ\text{F}$) for at least 30 min. Leave the mechanism used to remove the specimen from the medium in the medium except when handling the specimens.

NOTE 3—Temperatures up to $+260^\circ\text{C}$ ($+500^\circ\text{F}$) may be obtained with certain oils, but “flash-point” temperatures must be carefully observed.

NOTE 4—For testing at temperatures down to -196°C (-320°F , 77°K), standard testing procedures have been found to be adequate for most metals.

NOTE 5—A study has shown that a specimen heated to 100°C in water can cool 10°C in the 5 s allowed for transfer to the machine supports (1)⁶. Other studies, using cooling media that are above their boiling points at room temperature have also shown large changes in specimen temperature during the transfer of specimens to the machine anvils. In addition, some materials change temperature dramatically during impact testing at cryogenic temperatures due to adiabatic heating (2).

8.3 Charpy Test Procedure:

8.3.1 The Charpy test procedure may be summarized as follows: the test specimen is thermally conditioned and positioned on the specimen supports against the anvils; the pendu-

lum is released without vibration, and the specimen is impacted by the striker. Information is obtained from the machine and from the broken specimen.

8.3.2 To position a test specimen in the machine, it is recommended that self-centering tongs similar to those shown in Fig. 6 be used (see A1.10.1). The tongs illustrated in Fig. 6 are for centering V-notch specimens. If keyhole specimens are used, modification of the tong design may be necessary. If an end-centering device is used, caution must be taken to ensure that low-energy high-strength specimens will not rebound off this device into the pendulum and cause erroneously high recorded values. Many such devices are permanent fixtures of machines, and if the clearance between the end of a specimen in test position and the centering device is not approximately 13 mm (0.5 in.), the broken specimens may rebound into the pendulum.

8.3.3 To conduct the test, prepare the machine by raising the pendulum to the latched position, set the energy indicator at the maximum scale reading, or initialize the digital display, or both, position the specimen on the anvils, and release the pendulum. If a liquid bath or gas medium is being used for thermal conditioning, perform the following sequence in less than 5 s (for standard $10 \times 10 \times 55$ mm specimens, see 8.2.4). Remove the test specimen from its cooling (or heating) medium with centering tongs that have been temperature

⁶ The boldface numbers given in parentheses refer to a list of references at the end of the text.

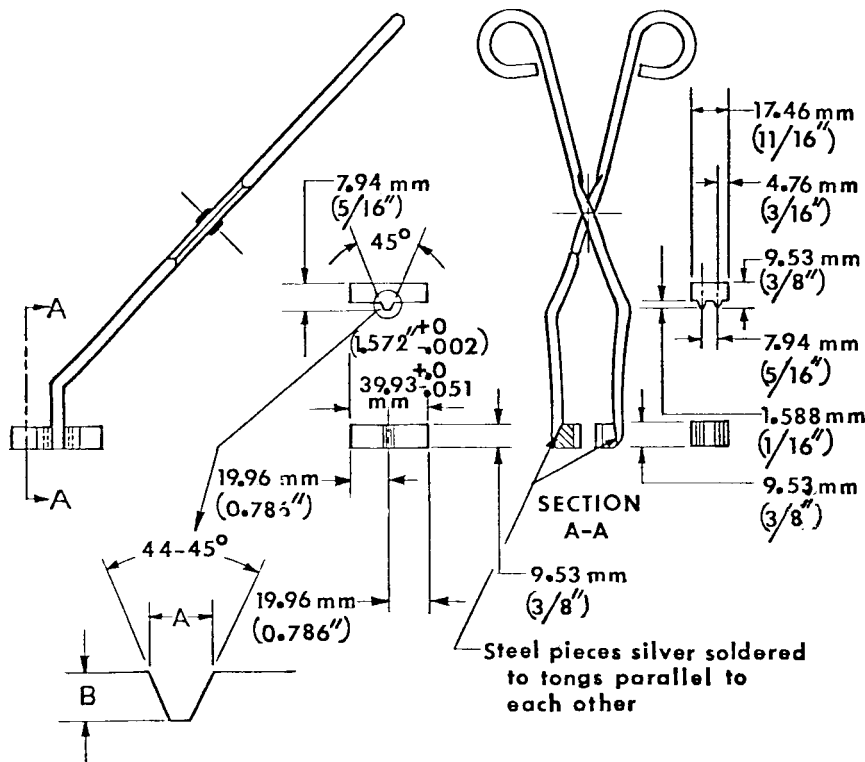

NOTE 1—Unless otherwise shown, permissible variation shall be ± 1 mm (0.04 in.).

Specimen Depth, mm (in.)	Base Width (A), mm (in.)	Height (B), mm (in.)
10 (0.394)	1.60 to 1.70 (0.063 to 0.067)	1.52 to 1.65 (0.060 to 0.065)
5 (0.197)	0.74 to 0.80 (0.029 to 0.033)	0.69 to 0.81 (0.027 to 0.032)
3 (0.118)	0.45 to 0.51 (0.016 to 0.020)	0.36 to 0.48 (0.014 to 0.019)

FIG. 6 Centering Tongs for V-Notch Charpy Specimens

conditioned with the test specimen, place the specimen in the test position, and, release the pendulum smoothly. If a test specimen has been removed from the temperature conditioning bath and it is questionable that the test can be conducted within the 5 s time frame, return the specimen to the bath for the time required in 8.2 before testing.

8.3.3.1 If a fractured impact specimen does not separate into two pieces, report it as unbroken. Unbroken specimens with absorbed energies of less than 80 % of the machine capacity may be averaged with values from broken specimens. If the individual values are not listed, report the percent of unbroken specimens with the average. If the absorbed energy exceeds 80 % of the machine capacity and the specimen passes completely between the anvils, report the value as approximate (see 10.1) and not averaged with the others. If an unbroken specimen does not pass between the machine anvils, the result will be reported as exceeding the machine capacity. A specimen shall never be struck more than once.

8.3.3.2 If a specimen jams in the machine, disregard the results and check the machine thoroughly for damage or maladjustment, which would affect its calibration.

8.3.3.3 To prevent recording an erroneous value, caused by jarring the indicator when locking the pendulum in its upright (“ready”) position, read the value for each test from the indicator prior to locking the pendulum for the next test.

8.4 Izod Test Procedure:

8.4.1 The Izod test procedure may be summarized as follows: the test specimen is positioned in the specimen-holding fixture and the pendulum is released without vibration. Information is obtained from the machine and from the broken specimen. The details are described as follows:

8.4.2 Testing at temperatures other than room temperature is difficult because the specimen-holding fixture for Izod specimens is often part of the base of the machine and cannot be readily cooled (or heated). Consequently, Izod testing is not recommended at other than room temperature.

8.4.3 Clamp the specimen firmly in the support vise so that the centerline of the notch is in the plane of the top of the vise within 0.125 mm (0.005 in.). Set the energy indicator at the maximum scale reading, and release the pendulum smoothly. Sections 8.3.3.1-8.3.3.3 inclusively, also apply when testing Izod specimens.

9. Information Obtainable from Impact Tests

9.1 *The absorbed energy* shall be taken as the difference between the energy in the striking member at the instant of impact with the specimen and the energy remaining after breaking the specimen. This value is determined by the machine’s scale reading which has been corrected for windage and friction losses.

NOTE 6—Alternative means for energy measurement are acceptable provided the accuracy of such methods can be demonstrated. Methods used in the past include optical encoders and strain gaged strikers.

9.2 *Lateral expansion measurement* methods must take into account the fact that the fracture path seldom bisects the point of maximum expansion on both sides of a specimen. One half of a broken specimen may include the maximum expansion for both sides, one side only, or neither. Therefore, the expansion

on each side of each specimen half must be measured relative to the plane defined by the undeformed portion on the side of the specimen, as shown in Fig. 7. For example, if A_1 is greater than A_2 , and A_3 is less than A_4 , then the lateral expansion is the sum of $A_1 + A_4$.

9.2.1 Before making any expansion measurements, it is essential that the two specimen halves are visually examined for burrs that may have formed during impact testing; if the burrs will influence the lateral expansion measurements, they must be removed (by rubbing on emery cloth or any other suitable method), making sure that the protrusions to be measured are not rubbed during the removal of the burr. Then, examine each fracture surface to ascertain that the protrusions have not been damaged by contacting an anvil, a machine mounting surface, ect. Lateral expansion shall not be measured on a specimen with this type of damage.

9.2.2 Lateral expansion shall not be reported for specimens that did not separate into two halves during the impact test, with one exception. The lateral expansion of an unbroken specimen can be reported if the following two conditions are met: the specimen can be separated by pushing the hinged halves together once and then pulling them apart without further fatiguing the specimen, and the lateral expansion measured for the unbroken specimen (prior to bending) is equal to or greater than that measured for the separated halves.

9.2.3 Lateral expansion may be measured easily by using a gage like the one shown in Fig. 8 (assembly and details shown in Fig. 9). Using this type of gage the measurement is made with the following procedure: orient the specimen halves so that the compression sides are facing each another, take one half of the fractured specimen and press it against the anvil and dial gage plunger and record the reading, make a similar measurement on the other half (same side) of the fractured specimen and disregard the lower of the two values, do the same for the other side of the fractured specimen, report the sum of the maximum expansions for the 2 sides as the lateral expansion for the specimen.

9.3 *The percentage of shear fracture* on the fracture surfaces of impact specimens may be determined using a variety of methods. The acceptable methods are defined in Annex A6.

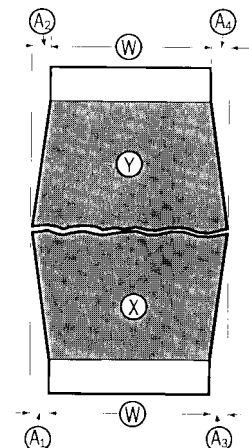

FIG. 7 Halves of Broken Charpy V-Notch Impact Specimen Illustrating the Measurement of Lateral Expansion, Dimensions A_1 , A_2 , A_3 , A_4 and Original Width, Dimension W

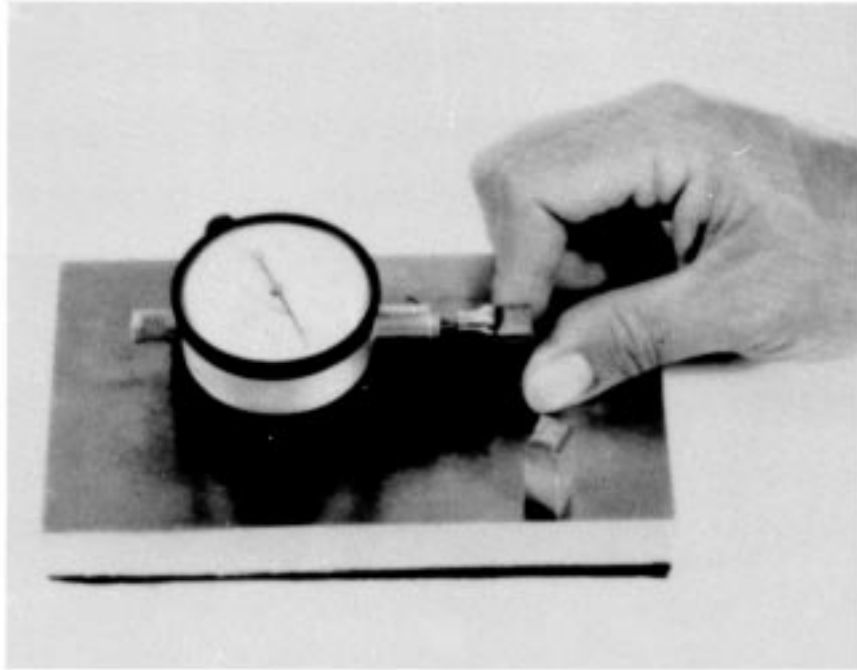

FIG. 8 Lateral Expansion Gage for Charpy Impact Specimens

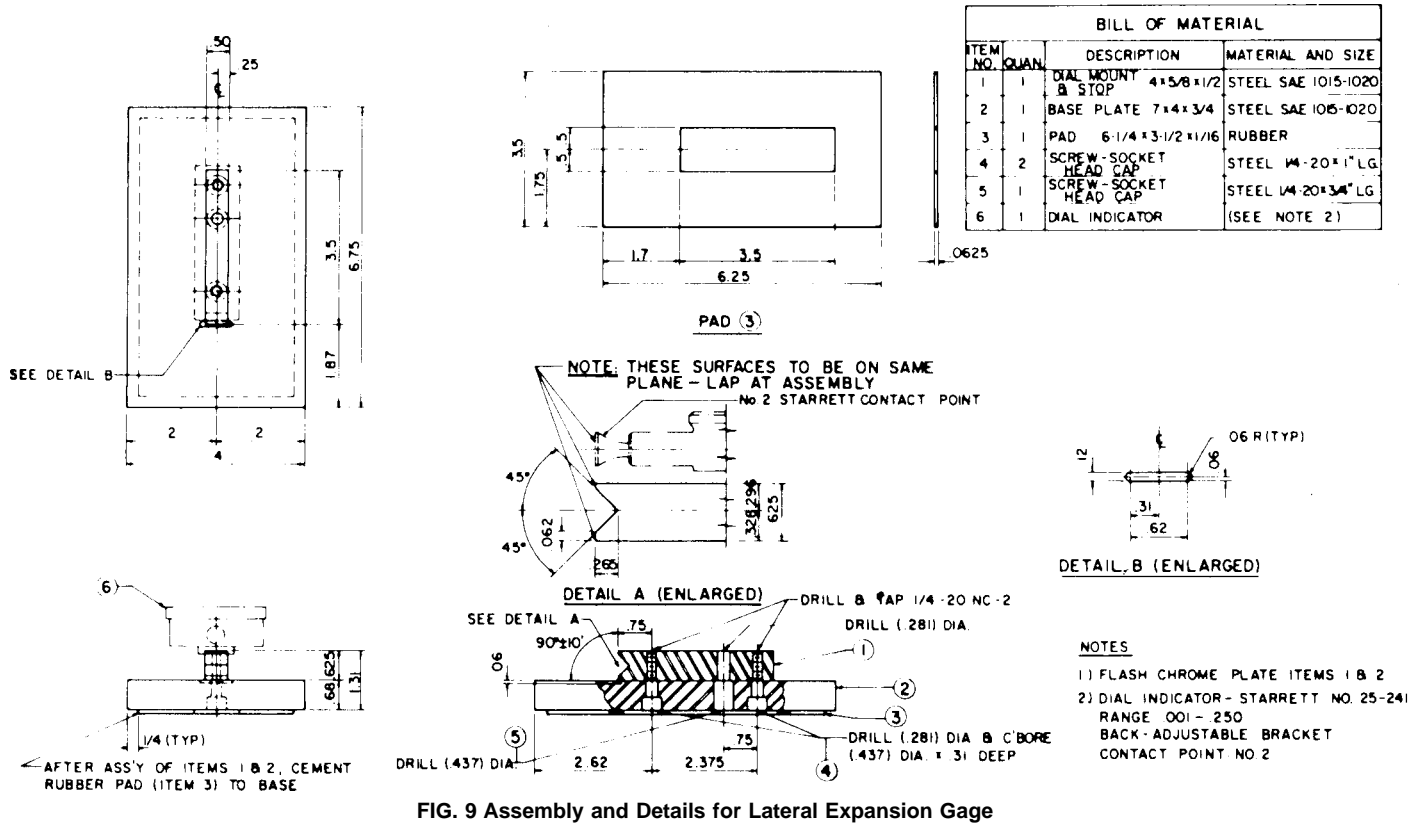
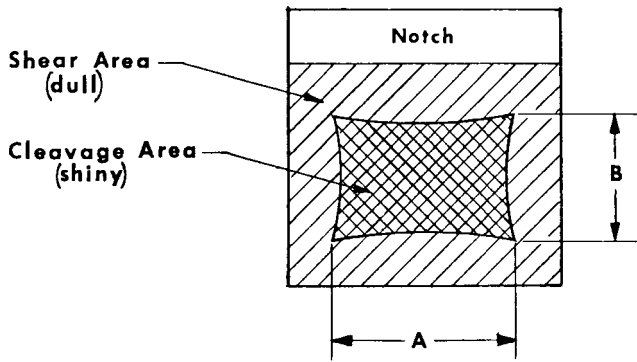

FIG. 9 Assembly and Details for Lateral Expansion Gage

For each method, the measurement must separate the shear fracture area from the flat fracture area, as depicted in Fig. 10. These methods provide no information on the fracture mode of the flat fracture region: the region could be 100 % cleavage, a

mixture of cleavage and ductile fracture areas (which can include shear), 100 % ductile, or other combinations of fracture features. The user should characterize the flat fracture zone and



NOTE 1—Measure average dimensions *A* and *B* to the nearest 0.5 mm or 0.02 in.

NOTE 2—Determine the percent shear fracture using Table 1 or Table 2.

FIG. 10 Determination of Percent Shear Fracture

provide an adequate description of how the shear measurements were made.

NOTE 7—Because of the subjective nature of the evaluation of fracture appearance, it is not recommended that it be used in specifications.

10. Report

10.1 *Absorbed energy values above 80 % of the scale range are inaccurate and shall be reported as approximate. Ideally an impact test would be conducted at a constant impact velocity. In a pendulum-type test, the velocity decreases as the fracture progresses. For specimens that have impact energies approaching 80 % of the capacity of the pendulum, the velocity of the pendulum decreases (to about 45 % of the initial velocity) during fracture to the point that accurate impact energies are no longer obtained.*

10.2 *For commercial acceptance testing, report the following information (for each specimen tested):*

- 10.2.1 Specimen type (and size if not the full-size specimen),
- 10.2.2 Test temperature,
- 10.2.3 Absorbed energy, and
- 10.2.4 Any other contractual requirements.

10.3 *For other than commercial acceptance testing the following information is often reported in addition to the information in 10.2:*

- 10.3.1 Lateral expansion,
- 10.3.2 Unbroken specimens,
- 10.3.3 Fracture appearance (% shear, See Note 7),
- 10.3.4 Specimen orientation, and
- 10.3.5 Specimen location.

NOTE 8—A recommended format for computerization of notched bar impact test data is available in Practice E 1313.

11. Precision and Bias

11.1 *An Interlaboratory study used CVN specimens of low energy and of high energy to find sources of variation in the CVN absorbed energy. Data from 29 laboratories were included with each laboratory testing one set of five specimens of each energy level. Except being limited to only two energy levels (by availability of reference specimens), Practice E 691 was followed for the design and analysis of the data, the details are given in ASTM Research Report NO. RR:E28-1014.⁷*

11.2 *Precision—The Precision information given below (in units of J and ft-lbf) is for the average CVN absorbed energy of five test determinations at each laboratory for each material.*

Material	Low Energy		High Energy	
	J	ft-lbf	J	ft-lbf
Absorbed Energy	15.9	11.7	96.2	71.0
95 % Repeatability Limit	2.4	1.7	8.3	6.1
95 % Reproducibility Limits	2.7	2.0	9.2	6.8

The terms repeatability and reproducibility limit are used as defined in Practice E 177. The respective standard deviations among test results may be obtained by dividing the above limits by 2.8.

11.3 *Bias— Bias cannot be defined for CVN absorbed energy. The physical simplicity of the pendulum design is complicated by complex energy loss mechanisms within the machine and the specimen. Therefore, there is no absolute standard to which the measured values can be compared.*

12. Keywords

12.1 charpy test; fracture appearance; Izod test; impact test; notched specimens; pendulum machine

⁷ Supporting data have been filed at ASTM Headquarters and may be obtained by requesting Research Report E28-1014.

ANNEXES

(Mandatory Information)

A1. GENERAL REQUIREMENTS FOR IMPACT MACHINES

A1.1 *The machine frame shall be equipped with a bubble level or a machined surface suitable for establishing levelness of the axis of pendulum bearings or, alternatively, the levelness of the axis of rotation of the pendulum may be measured directly. The machine shall be level to within 3:1000 and securely bolted to a concrete floor not less than 150 mm (6 in.) thick or, when this is not practical, the machine shall be bolted to a foundation having a mass not less than 40 times that of the*

pendulum. The bolts shall be tightened as specified by the machine manufacturer.

A1.2 *A scale or digital display, graduated in degrees or energy, on which readings can be estimated in increments of 0.25 % of the energy range or less shall be furnished for the machine.*

A1.2.1 The scales and digital displays may be compensated

for windage and pendulum friction. The error in the scale reading at any point shall not exceed 0.2 % of the range or 0.4 % of the reading, whichever is larger. (See A2.3.8.)

A1.3 *The total friction and windage losses* of the machine during the swing in the striking direction shall not exceed 0.75 % of the scale range capacity, and pendulum energy loss from friction in the indicating mechanism shall not exceed 0.25 % of scale range capacity. See A2.3.8 for friction and windage loss calculations.

A1.4 *The position of the pendulum*, when hanging freely, shall be such that the striker is within 2.5 mm (0.10 in.) from the test specimen. When the indicator has been positioned to read zero energy in a free swing, it shall read within 0.2 % of scale range when the striker of the pendulum is held against the test specimen. The plane of swing of the pendulum shall be perpendicular to the transverse axis of the Charpy specimen anvils or Izod vise within 3:1000.

A1.5 *Transverse play of the pendulum* at the striker shall not exceed 0.75 mm (0.030 in.) under a transverse force of 4 % of the effective weight of the pendulum applied at the center of strike. Radial play of the pendulum bearings shall not exceed 0.075 mm (0.003 in.).

A1.6 *The impact velocity* (tangential velocity) of the pendulum at the center of the strike shall not be less than 3 nor more than 6 m/s (not less than 10 nor more than 20 ft/s).

A1.7 *The height of the center of strike* in the latched position, above its free hanging position, shall be within 0.4 % of the range capacity divided by the supporting force, measured as described in A2.3.5.1 If windage and friction are compensated for by increasing the height of drop, the height of drop may be increased by not more than 1 %.

A1.8 *The mechanism for releasing the pendulum* from its initial position shall operate freely and permit release of the pendulum without initial impulse, retardation, or side vibration. If the same lever used to release the pendulum is also used to engage the brake, means shall be provided for preventing the brake from being accidentally engaged.

A1.9 *Specimen clearance* is needed to ensure satisfactory results when testing materials of different strengths and compositions. The test specimen shall exit the machine with a minimum of interference. Pendulums used on Charpy machines are of three basic designs, as shown in Fig. A1.1.

A1.9.1 When using a C-type pendulum or a compound pendulum, the broken specimen will not rebound into the pendulum and slow it down if the clearance at the end of the specimen is at least 13 mm (0.5 in.) or if the specimen is deflected out of the machine by some arrangement such as that shown in Fig. A1.1.

A1.9.2 When using the U-type pendulum, means shall be provided to prevent the broken specimen from rebounding against the pendulum (see Fig. A1.1). In most U-type pendulum machines, steel shrouds should be designed and installed

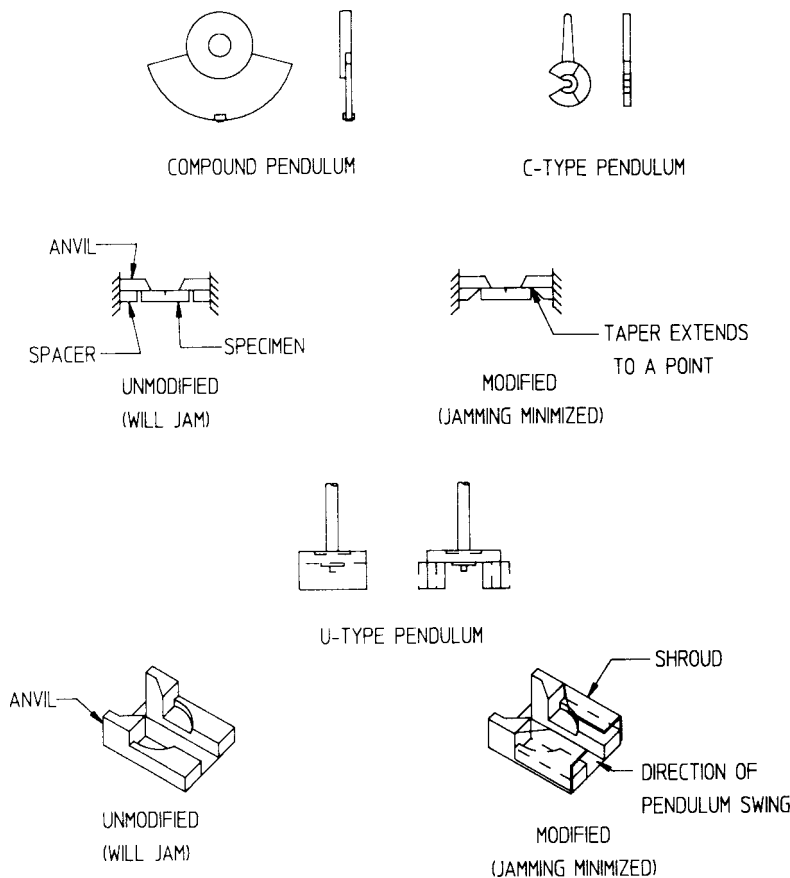

FIG. A1.1 Typical Pendulums and Anvils for Charpy Machines, Shown with Modifications to Minimize Jamming

to the following requirements: (*a*) have a thickness of approximately 1.5 mm (0.06 in.), (*b*) have a minimum hardness of 45 HRC, (*c*) have a radius of less than 1.5 mm (0.06 in.) at the underside corners, and (*d*) be so positioned that the clearance between them and the pendulum overhang (both top and sides) does not exceed 1.5 mm (0.06 in.).

NOTE A1.1—In machines where the opening within the pendulum permits clearance between the ends of a specimen (resting on the anvil supports) and the shrouds, and this clearance is at least 13 mm (0.5 in.), the requirements (*a*) and (*d*) need not apply.

A1.10 Charpy Apparatus:

A1.10.1 Means shall be provided (see Fig. A1.2) to locate and support the test specimen against two anvil blocks in such a position that the center of the notch can be located within 0.25 mm (0.010 in.) of the midpoint between the anvils (see 8.3.2).

A1.10.2 The supports and striker shall be of the forms and dimensions shown in Fig. A1.2. Other dimensions of the pendulum and supports should be such as to minimize interference between the pendulum and broken specimens.

A1.10.3 The center line of the striker shall advance in the plane that is within 0.40 mm (0.016 in.) of the midpoint between the supporting edges of the specimen anvils. The striker shall be perpendicular to the longitudinal axis of the specimen within 5:1000. The striker shall be parallel within 1:1000 to the face of a perfectly square test specimen held against the anvil.

A1.11 Izod Apparatus:

A1.11.1 Means shall be provided (see Fig. A1.3) for clamping the specimen in such a position that the face of the specimen is parallel to the striker within 1:1000. The edges of the clamping surfaces shall be sharp angles of $90 \pm 1^\circ$ with radii less than 0.40 mm (0.016 in.). The clamping surfaces shall be smooth with a 2- μ m (63- μ in.) finish or better, and shall clamp the specimen firmly at the notch with the clamping force applied in the direction of impact. For rectangular specimens, the clamping surfaces shall be flat and parallel within 0.025 mm (0.001 in.). For cylindrical specimens, the clamping surfaces shall be contoured to match the specimen and each surface shall contact a minimum of $\pi/2$ rad (90°) of the specimen circumference.

A1.11.2 The dimensions of the striker and its position relative to the specimen clamps shall be as shown in Fig. A1.3.

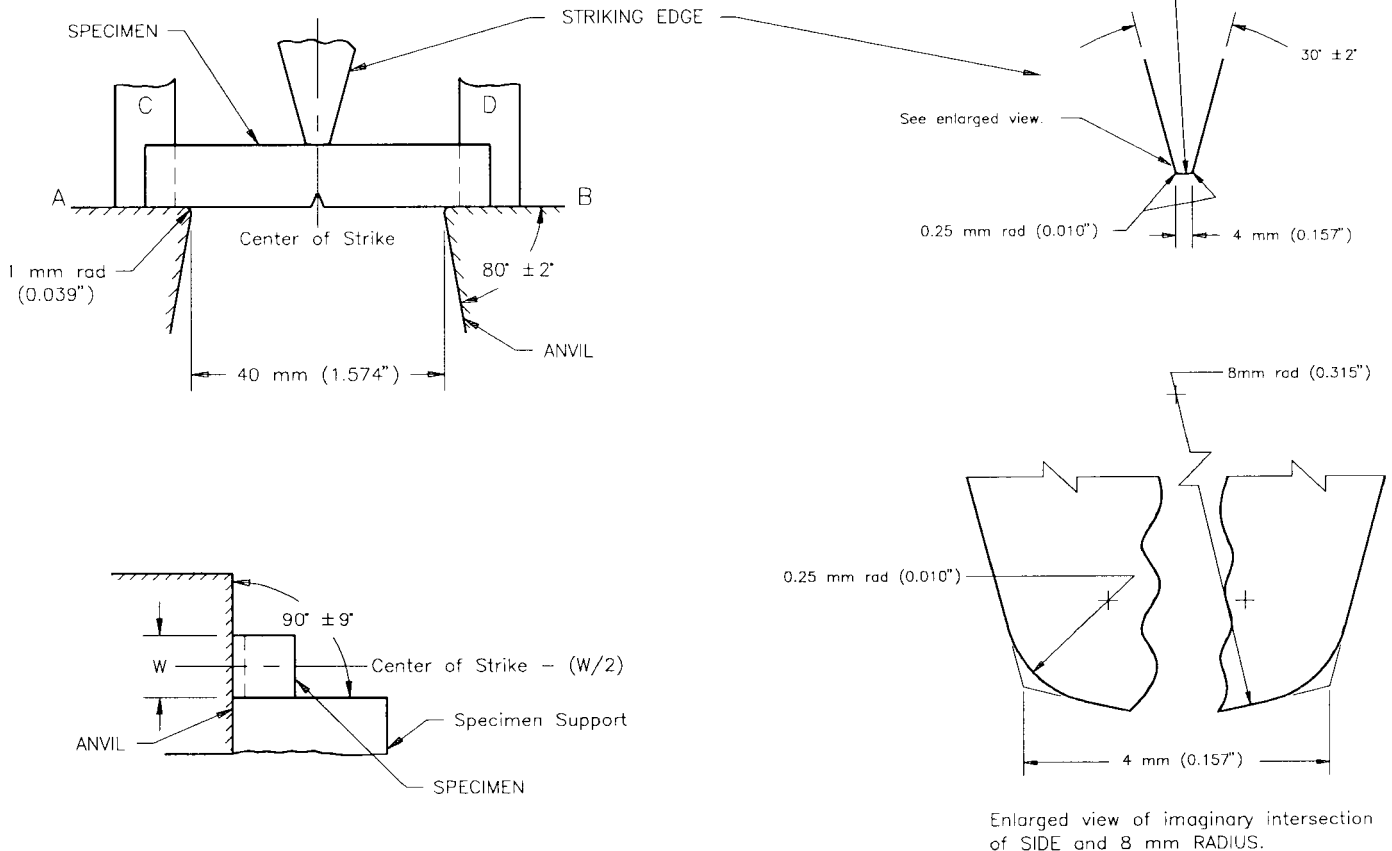

All dimensional tolerances shall be ±0.05 mm (0.002 in.) unless otherwise specified.

FIG. A1.2 Charpy Striking Tup

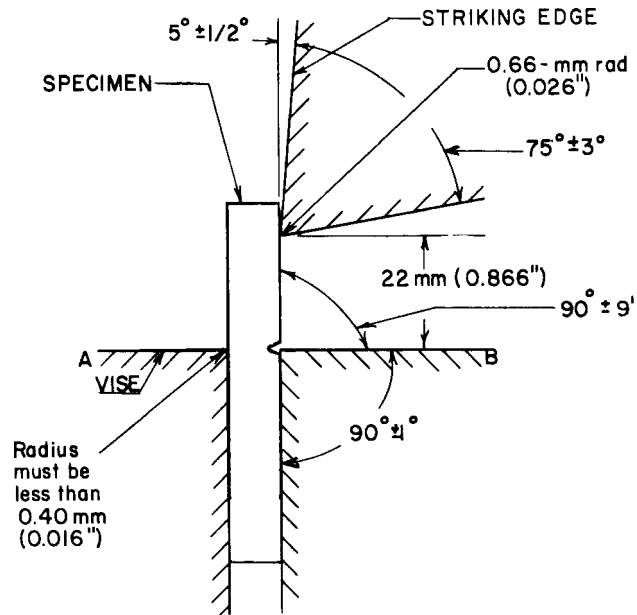

All dimensional tolerances shall be ± 0.05 mm (0.002 in.) unless otherwise specified.

NOTE 1—The clamping surfaces of A and B shall be flat and parallel within 0.025 mm (0.001 in.).

NOTE 2—Finish on unmarked parts shall be 2 μ m (63 μ in.).

NOTE 3—Striker width must be greater than that of the specimen being tested.

FIG. A1.3 Izod (Cantilever-Beam) Impact Test

A2. VERIFICATION OF PENDULUM IMPACT MACHINES

A2.1 *The verification of impact machines has two parts: direct verification, which consists of inspecting the machine to ensure that the requirements of this annex and Annex A1 are met, and indirect verification, which entails the testing of verification specimens.*

A2.1.1 Izod machines are verified by direct verification only.

A2.1.2 Charpy machines shall be verified annually. Data is valid only when produced within 365 days following the date of the most recent successful verification test. Charpy machines shall also be verified immediately after replacing parts that may affect the measured energy, after making repairs or adjustments, after they have been moved, or whenever there is reason to doubt the accuracy of the results, without regard to the time interval. These restrictions include cases where parts, which may affect the measured energy, are removed from the machine and then reinstalled without modification (for example, when the striker or anvils are removed to permit use of a different striker or set of anvils and then are reinstalled). It is not intended that parts not subjected to wear (such as pendulum and scale linearity) are to be directly verified each year unless a problem is evident. Only the items cited in A2.2 are required to be inspected annually. Other parts of the machine shall be directly verified at least once, when the machine is new, or when parts are replaced.

A2.2 *Direct Verification of Parts Requiring Annual Inspection:*

A2.2.1 Inspect the specimen supports, anvils, and striker and replace any of these parts that show signs of wear. A straight edge or radius gage can be used to discern differences between the used and unused portions of these parts to help identify a worn condition (see Note A2.1).

NOTE A2.1—To measure the anvil or striker radii, the recommended procedure is to make a replica (casting) of the region of interest and measure cross sections of the replica. This can be done with the anvils and striker in place on the machine or removed from the machine. Make a dam with cardboard and tape surrounding the region of interest, then pour a low-shrinkage casting compound into the dam (silicon rubber casting compounds work well). Allow the casting to cure, remove the dam, and slice cross sections through the region of interest with a razor. Use these cross sections to make radii measurements on optical comparators or other instruments.

A2.2.2 Ensure the bolts that attach the anvils and striker to the machine are tightened to the manufacturer's specifications.

A2.2.3 Verify that the shrouds, if applicable, are properly installed (see A1.9.2).

A2.2.4 The pendulum release mechanism, which releases the pendulum from its initial position, shall comply with A1.8.

A2.2.5 Check the level of the machine in both directions (see A1.1).

A2.2.6 Check that the foundation bolts are tightened to the manufacturer's specifications.

NOTE A2.2—Expansion bolts or fasteners with driven in inserts shall not be used for foundations. These fasteners will work loose and/or tighten up against the bottom of the machine indicating a false high torque value when the bolts are tightened.

A2.2.7 Check the indicator zero and the friction loss of the machine as described in 8.1.

A2.3 Direct Verification of Parts to be Verified at Least Once:

A2.3.1 Specimen anvils and supports or Izod vises shall conform to the dimensions shown in Fig. A1.2 or Fig. A1.3.

NOTE A2.3—The impact machine will be inaccurate to the extent that some energy is used in deformation or movement of its component parts or of the machine as a whole; this energy will be registered as used in fracturing the specimen.

A2.3.2 The striker shall conform to the dimensions shown in Fig. A1.2 or Fig. A1.3. The mounting surfaces must be clean and free of defects that would prevent a good fit. Check that the striker complies with A1.10.3 (for Charpy tests) or A1.11.1 (for Izod tests).

A2.3.3 The pendulum alignment shall comply with A1.4 and A1.5. If the side play in the pendulum or the radial play in the bearings exceeds the specified limits, adjust or replace the bearings.

A2.3.4 Determine the Center of Strike—For Charpy machines the center of strike of the pendulum is determined using a half-width specimen (10 by 5 mm) in the test position. With the striker in contact with the specimen, a line marked along the top edge of the specimen on the striker will indicate the center of strike. For Izod machines, the center of strike may be considered to be the contact line when the pendulum is brought into contact with a specimen in the normal testing position.

A2.3.5 Determine the Potential Energy—The following procedure shall be used when the center of strike of the pendulum is coincident with the radial line from the centerline of the pendulum bearings (herein called the axis of rotation) to the center of gravity (see Appendix X2). If the center of strike is more than 1.0 mm (0.04 in.) from this line, suitable corrections in elevation of the center of strike must be made in A2.3.8.1 and A2.3.9, so that elevations set or measured correspond to what they would be if the center of strike were on this line. The potential energy of the system is equal to the height from which the pendulum falls, as determined in A2.3.5.2, times the supporting force, as determined in A2.3.5.1

A2.3.5.1 To measure the supporting force, support the pendulum horizontally to within 15:1000 with two supports, one at the bearings (or center of rotation) and the other at the center of strike on the striker (see Fig. A2.1). Then arrange the support at the striker to react upon some suitable weighing device such as a platform scale or balance, and determine the weight to within 0.4 %. Take care to minimize friction at either point of support. Make contact with the striker through a round rod crossing the edge at a 90° angle. The supporting force is the scale reading minus the weights of the supporting rod and any shims that may be used to maintain the pendulum in a horizontal position.

A2.3.5.2 Determine the height of pendulum drop for compliance with the requirement of A1.7. On Charpy machines determine the height from the top edge of a half-width (or

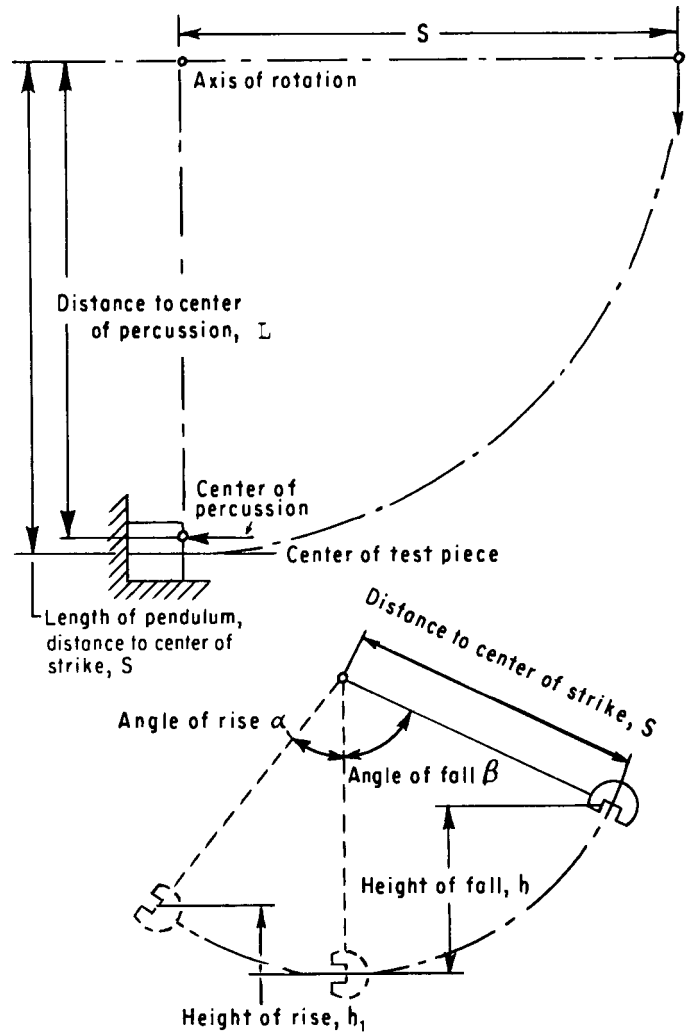

FIG. A2.1 Dimensions for Calculations

center of a full-width) specimen to the elevated position of the center of strike to 0.1 %. On Izod machines determine the height from a distance 22.66 mm (0.892 in.) above the vise to the release position of the center of strike to 0.1 %. The height may be determined by direct measurement of the elevation of the center of strike or by calculation from the change in angle of the pendulum using the following formulas (see Fig. A2.1):

$$h = S(1 - \cos(\beta)) \tag{A2.1}$$

$$h_1 = S(1 - \cos(\alpha)) \tag{A2.2}$$

where

- h = initial elevation of the striker, m (ft),
- S = length of the pendulum distance to the center of strike, m (ft),
- β = angle of fall,
- h_1 = height of rise, m (ft), and
- α = angle of rise.

A2.3.6 Determine the impact velocity, $[v]$, of the machine, neglecting friction, by means of the following equation:

$$v = \sqrt{2gh} \tag{A2.3}$$

where:

v = velocity, m/s (ft/s),
 g = acceleration of gravity, 9.81 m/s² (32.2 ft/s²), and
 h = initial elevation of the striker, m (ft).

A2.3.7 The center of percussion shall be at a point within 1 % of the distance from the axis of rotation to the center of strike in the specimen, to ensure that minimum force is transmitted to the point of rotation. Determine the location of the center of percussion as follows:

A2.3.7.1 Using a stop watch or some other suitable time-measuring device, capable of measuring time to within 0.2 s, swing the pendulum through a total angle not greater than 15° and record the time for 100 complete cycles (to and fro). The period of the pendulum then, is the time for 100 cycles divided by 100.

A2.3.7.2 Determine the center of percussion by means of the following equation:

$$L = \frac{gp^2}{4\pi^2} \quad (\text{A2.4})$$

where:

L = distance from the axis to the center of percussion, m (ft),
 g = local gravitational acceleration (accuracy of one part in one thousand), m/s² (ft/s²),
 π = 3.1416, and
 p = period of a complete swing (to and fro), s.

A2.3.8 *Determination of the Friction Losses*—The energy loss from friction and windage of the pendulum and friction in the recording mechanism, if not corrected, will be included in the energy loss attributed to breaking the specimen and can result in erroneously high measurements of absorbed energy. For machines recording in degrees, frictional losses are usually not compensated for by the machine manufacturer, whereas in machines recording directly in energy, they are usually compensated for by increasing the starting height of the pendulum. Determine energy losses from friction as follows:

A2.3.8.1 Without a specimen in the machine, and with the indicator at the maximum energy reading, release the pendulum from its starting position and record the energy value indicated. This value should indicate zero energy if frictional losses have been corrected by the manufacturer. Now raise the pendulum slowly until it just contacts the indicator at the value obtained in the free swing. Secure the pendulum at this height and determine the vertical distance from the center of strike to the top of a half-width specimen positioned on the specimen rest supports within 0.1 % (see A2.3.5). Determine the supporting force as in A2.3.5.1 and multiply by this vertical distance. The difference in this value and the initial potential energy is the total energy loss in the pendulum and indicator combined. Without resetting the pointer, repeatedly release the pendulum from its initial position until the pointer shows no further movement. The energy loss determined by the final position of the pointer is that due to the pendulum alone. The frictional loss in the indicator alone is then the difference between the combined indicator and pendulum losses and those due to the pendulum alone.

A2.3.9 The indicating mechanism accuracy shall be

checked to ensure that it is recording accurately over the entire range (see A1.2.1). Check it at graduation marks corresponding to approximately 0, 10, 20, 30, 50, and 70 % of each range. With the striker marked to indicate the center of strike, lift the pendulum and set it in a position where the indicator reads, for example, 13 J (10 ft·lbf). Secure the pendulum at this height and determine the vertical distance from the center of strike to the top of a half-width specimen positioned on the specimen supports within 0.1 % (see A2.3.5). Determine the residual energy by multiplying the height of the center of strike by the supporting force, as described in A2.3.5.1. Increase this value by the total frictional and windage losses for a free swing (see A2.3.8.1) multiplied by the ratio of the angle of swing of the pendulum from the latch to the energy value being evaluated to the angle of swing of the pendulum from the latch to the zero energy reading. Subtract the sum of the residual energy and proportional frictional and windage loss from the potential energy at the latched position (see A2.3.5). The indicator shall agree with the energy calculated within the limits of A1.2.1. Make similar calculations at other points of the scale. The indicating mechanism shall not overshoot or drop back with the pendulum. Make test swings from various heights to check visually the operation of the pointer over several portions of the scale.

NOTE A2.4—Indicators that indicate in degrees shall be checked using the above procedure. Degree readings from the scale shall be converted to energy readings using the conversion formula or table normally used in testing. In this way the formula or table can also be checked for windage and friction corrections.

A2.4 *Indirect Verification:*

A2.4.1 Indirect verification requires the testing of specimens with certified values to verify the accuracy of Charpy impact machines.

A2.4.1.1 Verification specimens with certified values are produced at low (12 to 20 J), high (88 to 115 J), and super-high (210 to 230 J) energy levels. To meet the verification requirements, the average value determined for a set of verification specimens at each energy level tested shall correspond to the certified values of the verification specimens within 1.4 J (1.0 ft·lbf) or 5.0 %, whichever is greater.

A2.4.1.2 Verification specimens are available from the National Institute of Standards and Technology (NIST) through the Standard Reference Materials Program (see Annex A3). Other sources of verification specimens may be used provided they conform to Practice E 1271 and their reference value has been established on the three reference machines owned, maintained, and operated by NIST in Boulder, CO.

NOTE A2.5—Verification specimens are available for Charpy machines only. Detailed information pertaining to the availability of verification specimens is given in Appendix X3.

A2.4.2 The verified range of a Charpy impact machine is described with reference to the lowest and highest energy specimens tested on the machine. These values are determined from tests on sets of verification specimens at two or more levels of absorbed energy, except in the case where a Charpy machine has a maximum capacity that is too low for two energy levels to be tested. In this case, one level of absorbed energy can be used for indirect verification.

A2.4.3 Determine the usable range of the impact testing machine prior to testing verification specimens. The usable range of an impact machine is dependent upon the resolution of the scale or readout device at the low end and the capacity of the machine at the high end.

A2.4.3.1 The resolution of the scale or readout device establishes the lower limit of the usable range for the machine. The lower limit is equal to 25 times the resolution of the scale or readout device at 15J (11 ft-lbf).

NOTE A2.6—On analog scales, the resolution is the smallest change in energy that can be discerned on the scale. This is usually 1/4 to 1/5 of the difference between 2 adjacent marks on the scale at the 15J (11 ft-lbf) energy level.

NOTE A2.7—Digital scales usually incorporate devices, such as digital encoders, with a fixed discrete angular resolution. The resolution of these types of readout devices is the smallest change in energy that can be consistently measured at 15J. The resolution of these types of devices is usually not a change in the last digit shown on the display because resolution is a function of the angular position of the pendulum and changes throughout the swing. For devices which incorporate a verification mode in which a live readout of absorbed energy is available, the pendulum may be moved slowly in the area of 15 J to observe the smallest change in the readout device (the resolution).

A2.4.3.2 The upper limit of the usable range of the machine is equal to 80 % of the capacity of the machine.

A2.4.4 Only verification specimens that are within the usable range of the impact machine shall be tested. To verify the machine over its full usable range, test the lowest and highest energy levels of verification specimens commercially available that are within the machines' usable range. If the ratio of the highest and lowest certified values tested is greater than four, testing of a third set of intermediate energy specimens is required (if the specimens are commercially available).

NOTE A2.8—Use the upper bound of the energy range given for the low, high, and super-high verification specimens (20, 115, and 230 J respectively to determine the highest energy level verification specimens

that can be tested. Alternately, use the lower bound of the energy range given for the verification specimens to determine the minimum energy level for testing.

A2.4.4.1 If the low energy verification specimens were not tested (tested only high and super-high), the lower limit of the verified range shall be one half the energy of the lowest energy verification set tested.

NOTE A2.9—For example, if the certified value of the high energy specimens tested was 100J, the lower limit would be 50J.

A2.4.4.2 If the highest energy verification specimens available for a given Charpy machine capacity have not been tested, the upper value of the verified range shall be 1.5 times the certified value of the highest energy specimens tested.

NOTE A2.10—For example, if the machine being tested has a maximum capacity of 325 J (240 ft-lbf) and only low and high energy verification specimens were tested, the upper bound of the verified range would be 150 J (100 J * 1.5 = 150 J), assuming that the high energy samples tested had a certified value of 100J. To verify this machine over its full range, low, high, and super-high verification specimens would have to be tested, because super-high verification specimens can be tested on a machine with a 325J capacity (80 % of 325J is 260J, and the certified value of super-high specimens never exceed 230J). See Table A2.1.

TABLE A2.1 Verified Ranges for Various Machine Capacities and Verification Specimens Tested^A

Machine Capacity J	Resolution J	Usable Range J	Verification Specimens Tested			Verified Range J
			Low	High	Super-high	
80	0.10	2.5 to 64	X	2.5 to 64
160	0.20	5.0 to 128	X	X	...	5.0 to 128
325	0.25	6.25 to 260	X	X	X	6.25 to 260
400	0.30	7.5 to 320	...	X	X	50 to 320
400	0.15	3.75 to 320	X	X	...	3.75 to 150
400	0.15	3.75 to 320	X	X	X	3.75 to 320

^AIn these examples, the high energy verification specimens are assumed to have a certified value of 100J.

A3. ADDITIONAL IMPACT TEST SPECIMEN CONFIGURATIONS

A3.1 *Sub-Size Specimen*—When the amount of material available does not permit making the standard impact test specimens shown in Figs. 1 and 2, smaller specimens may be used, but the results obtained on different sizes of specimens cannot be compared directly (X1.3). When Charpy specimens other than the standard are necessary or specified, it is recommended that they be selected from Fig. A3.1.

A3.2 *Supplementary Specimens*—For economy in preparation of test specimens, special specimens of round or rectangular cross section are sometimes used for cantilever beam test.

These are shown as Specimens X, Y, and Z in Figs. A3.2 and A3.3. Specimen Z is sometimes called the Philpot specimen, after the name of the original designer. For hard materials, the machining of the flat surface struck by the pendulum is sometimes omitted. Types Y and Z require a different vise from that shown in Fig. A1.3, each half of the vise having a semi-cylindrical recess that closely fits the clamped portion of the specimen. As previously stated, the results cannot be reliably compared with those obtained using specimens of other sizes or shapes.

On subsize specimens the length, notch angle, and notch radius are constant (see Fig. 1); depth (*D*), notch depth (*N*), and width (*W*) vary as indicated below.

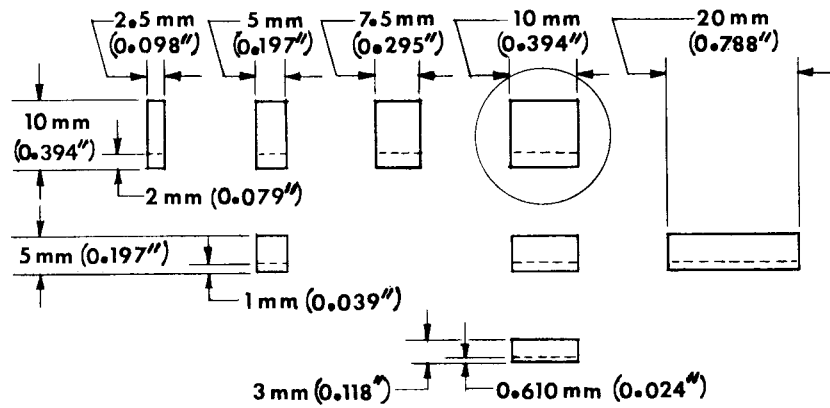
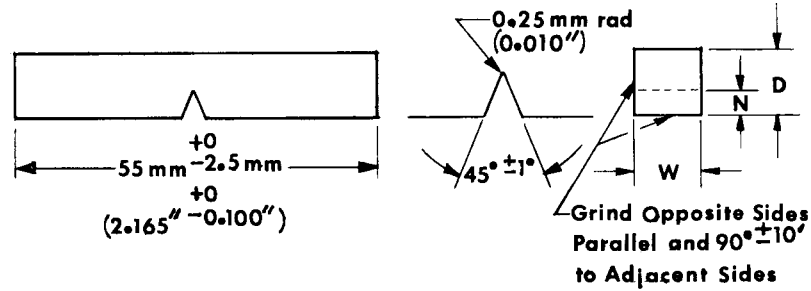

NOTE 1—Circled specimen is the standard specimen (see Fig. 1).

NOTE 2—Permissible variations shall be as follows:

Cross-section dimensions	±1 % or ±0.075 mm (0.003 in.), whichever is smaller
Radius of notch	±0.025 mm (0.001 in.)
Depth of notch	±0.025 mm (0.001 in.)
Finish requirements	2 μm (63 μin.) on notched surface and opposite face; 4 μm (125 μin.) on other two surfaces

FIG. A3.1 Charpy (Simple-Beam) Subsize (Type A) Impact Test Specimens

E 23

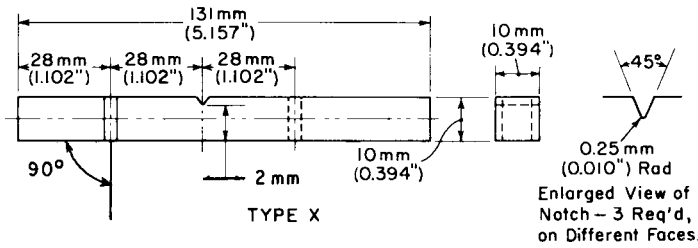

NOTE 1—Permissible variations for type X specimens shall be as follows:

Notch length to edge	90 ± 2°
Adjacent sides shall be at	90° ± 10 min
Notch depth of Type X specimen	±0.025 mm (±0.001 in.)

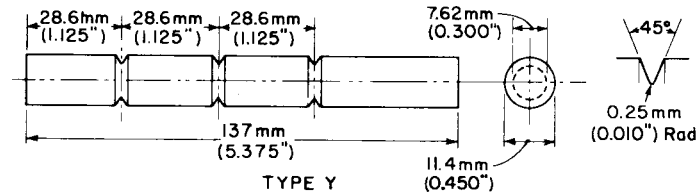

NOTE 2—Permissible variations for both specimens shall be as follows:

Cross-section dimensions	±0.025 mm (±0.001 in.)
Lengthwise dimensions	+0, -2.5 mm (+0, -0.100 in.)
Angle of notch	±1°
Radius of notch	±0.025 mm (±0.001 in.)
Notch diameter of Type Y specimen	±0.025 mm (±0.001 in.)

FIG. A3.2 Izod (Cantilever-Beam) Impact Test Specimens, Types X and Y

The flat shall be parallel to the longitudinal centerline of the specimen and shall be parallel to the bottom of the notch within 2:1000.

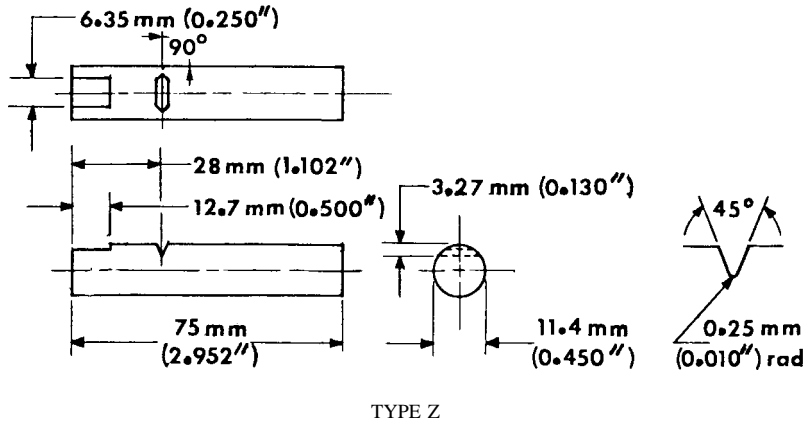

NOTE 1—Permissible variations shall be as follows:

Notch length to longitudinal centerline	90 ± 2°
Cross-section dimensions	±0.025 mm (±0.001 in.)
Length of specimen	+0, -2.5 mm (+0 -0.100 in.)
Angle of notch	±1°
Radius of notch	±0.025 mm (±0.001 in.)
Notch depth	±0.025 mm (.130 ± 0.001 in.)

FIG. A3.3 Izod (Cantilever-Beam) Impact Test Specimen (Philpot), Type Z

A4. PRECRACKING CHARPY V-NOTCH IMPACT SPECIMENS

A4.1 Scope

A4.1.1 This annex describes the procedure for the fatigue precracking of standard Charpy V-notch (CVN) impact speci-

mens. The annex provides information on applications of precracked Charpy impact testing and fatigue-precracking procedures.

A4.2 Significance and Use

A4.2.1 Section 4 also applies to precracked Charpy V-notch impact specimens.

A4.2.2 It has been found that fatigue-precracked CVN specimens generally result in better correlations with other impact toughness tests such as Test Method E 604 and with fracture toughness tests such as Test Method E 399 than the standard V-notch specimens (3,4,5,6,7,8). Also, the sharper notch yields more conservative estimations of the notched impact toughness and the transition temperature of the material (9,10).

A4.3 Apparatus

A4.3.1 The equipment for fatigue cracking shall be such that the stress distribution is symmetrical through the specimen thickness; otherwise, the crack will not grow uniformly. The stress distribution shall also be symmetrical about the plane of the prospective crack; otherwise the crack will deviate unduly from that plane and the test result will be significantly affected.

A4.3.2 The recommended fixture to be used is shown in Fig. A4.1. The nominal span between support rollers shall be $4D \pm 0.2D$, where D is the depth of the specimen. The diameter of the rollers shall be between $D/2$ and D . The radius of the ram shall be between $D/8$ and D . This fixture is designed to minimize frictional effects by allowing the support rollers to rotate and move apart slightly as the specimen is loaded, thus permitting rolling contact. The rollers are initially positioned against stops that set the span length and are held in place by low-tension springs (such as rubber bands). Fixtures, rolls, and ram should be made of high hardness (greater than 40 HRC) steels.

A4.4 Test Specimens

A4.4.1 The dimensions of the precracked Charpy specimen are essentially those of type-A shown in Fig. A4.2. The notch depth plus the fatigue crack extension length shall be designated as N . When the amount of material available does not permit making the standard impact test specimen, smaller specimens may be made by reducing the width; but the results obtained on different sizes of specimens cannot be compared directly (see X1.3).

A4.4.2 The fatigue precracking is to be done with the material in the same heat-treated condition as that in which it will be impact tested. No intermediate treatments between fatigue precracking and testing are allowed.

A4.4.3 Because of the relatively blunt machined V-notch in the Charpy impact specimen, fatigue crack initiation can be difficult. Early crack initiation can be promoted by pressing or milling a sharper radius into the V-notch. Care must be taken to ensure that excessive deformation at the crack tip is avoided.

A4.4.4 It is advisable to mark two pencil lines on each side of the specimen normal to the anticipated paths of the surface traces of the fatigue crack. The first line should indicate the point at which approximately two-thirds of the crack extension has been accomplished. At this point, the stress intensity applied to the specimen should be reduced. The second line should indicate the point of maximum crack extension. At this point, fatigue precracking should be terminated.

A4.5 Fatigue Precracking Procedure

A4.5.1 Set up the test fixture so that the line of action of the applied load shall pass midway between the support roll center within 1 mm. Measure the span to within 1 % of the nominal

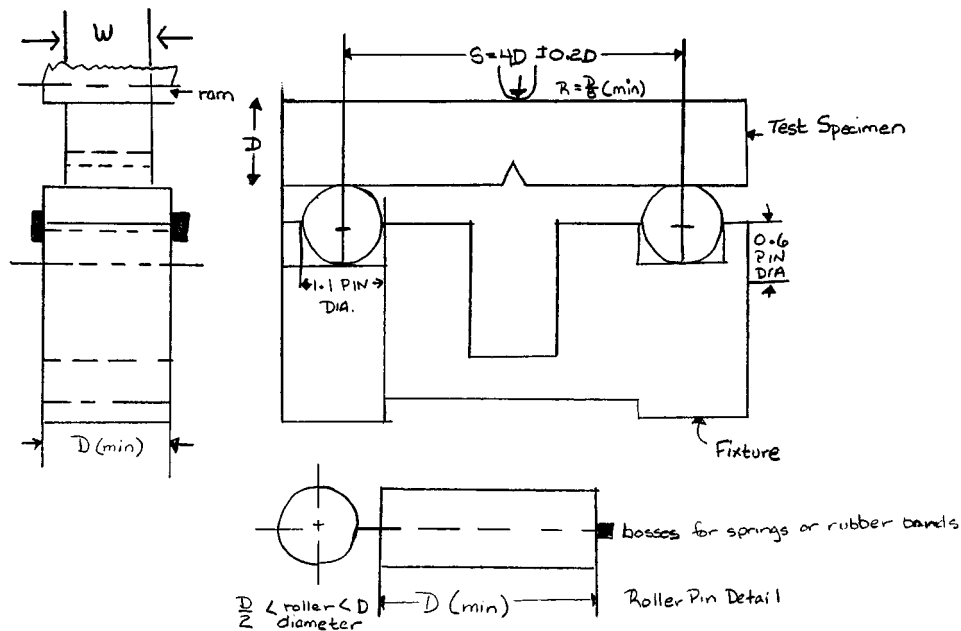

- L = length = 55 mm +0, -2.5 mm,
- D = depth = 10 mm ± 0.075 mm,
- W = variable width (see A3.1),
- N = notch depth = 2 mm ± 0.025 mm, included angle of notch = 45° ± 1°, and radius of notch = 0.25 mm ± 0.025 mm.

FIG. A4.1 Fatigue Precracking-Fixture Design

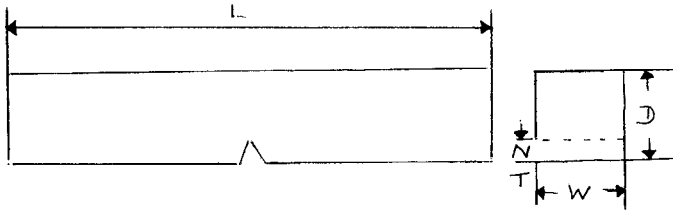

FIG. A4.2 Charpy (Simple-Beam, type A) Impact Test Specimen

length. Locate the specimen with the crack tip midway between the rolls within 1 mm of the span, and square to the roll axes within 2°.

A4.5.2 Select the initial loads used during precracking so that the remaining ligament remains undamaged by excessive plasticity. If the load cycle is maintained constant, the maximum K (stress intensity) and the K range will increase with crack length; care must be taken to ensure that the maximum K value is not exceeded to prevent excessive plastic deformation at the crack tip. This is done by continually shedding the load as the fatigue crack extends. The maximum load to be used at any instant can be calculated from Eq A4.1 and A4.2 while the minimum load should be kept at 10 % of the maximum. Eq A4.1 relates the maximum load to a stress intensity (K) value for the material that will ensure an acceptable plastic-zone size at the crack tip. It is also advisable to check this maximum load to ensure that it is below the limit load for the material using Eq A4.2. When the most advanced crack trace has almost reached the first scribed line corresponding to approximately two-thirds of the final crack length, reduce the maximum load so that $0.6 K_{max}$ is not exceeded.

A4.5.3 Fatigue cycling is begun, usually with a sinusoidal waveform and near to the highest practical frequency. There is no known marked frequency effect on fatigue precrack formation up to at least 100 Hz in the absence of adverse environments; however, frequencies of 15 to 30 Hz are typically used. Carefully monitor the crack growth optically. A low-power magnifying glass is useful in this regard. If crack growth is not observed on one side when appreciable growth is observed on the first, stop fatigue cycling to determine the cause and remedy for the behavior. Simply turning the specimen around in relation to the fixture will often solve the problem. When the most advanced crack trace has reached the halfway mark, turn the specimen around in relation to the fixture and complete the fatigue cycling. Continue fatigue cycling until the surface traces on both sides of the specimen indicate that the desired overall length of notch plus crack is reached. The fatigue crack should extend at least 1 mm beyond the tip of the V-notch but no more than 3 mm. A fatigue crack extension of approximately 2 mm is recommended.

A4.5.4 When fatigue cracking is conducted at a temperature T_1 and testing will be conducted at a different temperature T_2 , and $T_1 > T_2$, the maximum stress intensity must not exceed 60 % of the K_{max} of the material at temperature T_1 multiplied by the ratio of the yield stresses of the material at the temperatures T_1 and T_2 , respectively. Control of the plastic-zone size during fatigue cracking is important when the fatigue cracking is done at room temperature and the test is conducted at lower temperatures. In this case, the maximum stress intensity at room temperature must be kept to low values so

that the plastic-zone size corresponding to the maximum stress intensity at low temperatures is smaller.

A4.6 Calculation

A4.6.1 Specimens shall be precracked in fatigue at load values that will not exceed a maximum stress intensity, K_{max} , or three-point bend specimens use:

$$P_{max} = [K_{max} * W * D^{3/2}] / [S * f(N/D)] \tag{A4.1}$$

where:

- P_{max} = maximum load to be applied during precracking,
- K_{max} = maximum stress intensity = $\sigma_{ys} * (2 * \pi * r_y)^{1/2}$,
where r_y = is the radius of the induced plastic zone size which should be less than or equal to 0.5 mm,
- D = specimen depth,
- W = specimen width,
- S = span, and
- $f(N/D)$ = geometrical factor (see Table A4.1).

A4.6.2 See the appropriate section of Test Method E 399 for the $f(N/D)$ calculation. Table A4.1 contains calculated values for $f(N/D)$ for CVN precracking. Eq A4.2 should be used to ensure that the loads used in fatigue cracking are well below the calculated limit load for the material.

$$P_L = (4/3) * [D * (D - N)^2 * \sigma_{ys}] / S \tag{A4.2}$$

where:

- P_L = limit load for the material.

A4.7 Crack Length Measurement

A4.7.1 After fracture, measure the initial notch plus fatigue crack length, N , to the nearest 1 % at the following three

N (mm)	D (mm)	N/D	f(N/D)
2.00	10.00	0.20	1.17
2.10	10.00	0.21	1.21
2.20	10.00	0.22	1.24
2.30	10.00	0.23	1.27
2.40	10.00	0.24	1.31
2.50	10.00	0.25	1.34
2.60	10.00	0.26	1.37
2.70	10.00	0.27	1.41
2.80	10.00	0.28	1.45
2.90	10.00	0.29	1.48
3.00	10.00	0.30	1.52
3.10	10.00	0.31	1.56
3.20	10.00	0.32	1.60
3.30	10.00	0.33	1.64
3.40	10.00	0.34	1.69
3.50	10.00	0.35	1.73
3.60	10.00	0.36	1.78
3.70	10.00	0.37	1.83
3.80	10.00	0.38	1.88
3.90	10.00	0.39	1.93
4.00	10.00	0.40	1.98
4.10	10.00	0.41	2.04
4.20	10.00	0.42	2.10
4.30	10.00	0.43	2.16
4.40	10.00	0.44	2.22
4.50	10.00	0.45	2.29
4.60	10.00	0.46	2.35
4.70	10.00	0.47	2.43
4.80	10.00	0.48	2.50
4.90	10.00	0.49	2.58
5.00	10.00	0.50	2.66

positions: at the center of the crack front and midway between the center and the intersection of the crack front with the specimen surfaces. Use the average of these three measurements as the crack length.

A4.7.2 If the difference between any two of the crack length measurements exceeds 10 % of the average, or if part of the crack front is closer to the machine notch root than 5 % of the average, the specimen should be discarded. Also, if the length of either surface trace of the crack is less than 80 % of the average crack length, the specimen should be discarded.

A4.8 Report

A4.8.1 Report the following information for each specimen

tested: type of specimen used (and size if not the standard size), test temperatures, and energy absorption. Report the average precrack length in addition to these Test Method E 23 requirements.

A4.8.2 The following information may be provided as supplementary information: lateral expansion, fracture appearance, and also, it would probably be useful to report energy absorption normalized in some manner.

A5. SPECIMEN ORIENTATION

A5.1 Designation of Specimen Axis:

A5.1.1 The L-axis is coincident with the main direction of grain flow due to processing. This axis is usually referred to as the longitudinal direction (see Fig. A5.1, Fig. A5.2, and Fig. A5.3).

A5.1.2 The S-axis is coincident with the direction of the main working force. This axis is usually referred to as the short-transverse-direction.

A5.1.3 The T-axis is normal to the L- and S-axes. This axis is usually referred to as the transverse direction.

A5.1.4 Specimens parallel to the surface of wrought products, processed with the same degree of homogenous deformation along the L- and T axes may be called T specimens.

A5.1.5 Specimens normal to the uniform grain flow of wrought products (or grain growth in cast products), whose grain flow is exclusively in one direction, so that T- and S specimens are equivalent, may be called S specimens.

A5.2 Designation of Notch Orientation:

A5.2.1 The notch orientation is designated by the direction

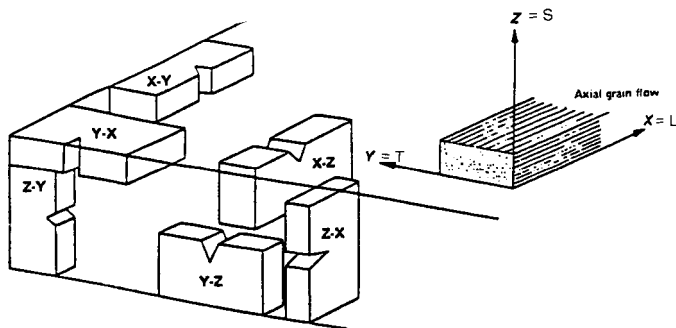
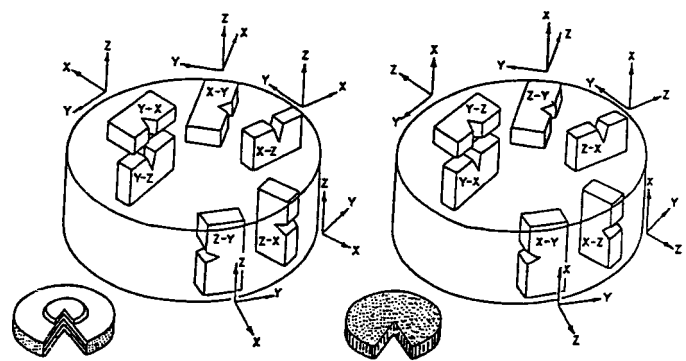

FIG. A5.1 Fracture Planes Along Principal Axes



a) Radial grain flow, axial working direction b) Axial grain flow, radial working direction

FIG. A5.2 Fracture Planes—Cylindrical Sections

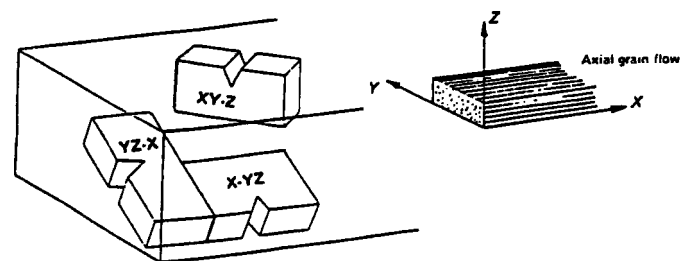

FIG. A5.3 Fracture Planes not Along Principal Axes

in which fracture propagates. This letter is separated from the specimen-axis designation by a hyphen. In unique cases (Fig. A5.3), when fracture propagates across two planes, two letters are required to designate notch orientation.

A6. DETERMINATION OF THE PROPORTION OF SHEAR FRACTURE SURFACE

A6.1 The methods described here may be used to determine the percent shear fracture on the surface of impact specimens.

A6.1.1 Measure the length and width of the flat fracture region of the fracture surface, as shown in Fig. 10, and determine the percent shear from either Table A6.1 or Table A6.2 depending on the units of measurement.

A6.1.2 Compare the appearance of the fracture of the specimen with a fracture appearance chart such as that shown in Fig. A6.1.

A6.1.3 Magnify the fracture surface and compare it to a precalibrated overlay chart or measure the percent shear fracture by means of a planimeter.

A6.1.4 Photograph the fracture surface at a suitable magnification and measure the percent shear fracture by means of a planimeter.

A6.1.5 Capture a digital image of the fracture surface and measure the percent shear fracture using image analysis software.

TABLE A6.1 Percent Shear for Measurements Made in Millimetres

NOTE 1—100 % shear is to be reported when either *A* or *B* is zero.

Dimension <i>B</i> , mm	Dimension <i>A</i> , mm																		
	1.0	1.5	2.0	2.5	3.0	3.5	4.0	4.5	5.0	5.5	6.0	6.5	7.0	7.5	8.0	8.5	9.0	9.5	10
1.0	99	98	98	97	96	96	95	94	94	93	92	92	91	91	90	89	89	88	88
1.5	98	97	96	95	94	93	92	92	91	90	89	88	87	86	85	84	83	82	81
2.0	98	96	95	94	92	91	90	89	88	86	85	84	82	81	80	79	77	76	75
2.5	97	95	94	92	91	89	88	86	84	83	81	80	78	77	75	73	72	70	69
3.0	96	94	92	91	89	87	85	83	81	79	77	76	74	72	70	68	66	64	62
3.5	96	93	91	89	87	85	82	80	78	76	74	72	69	67	65	63	61	58	56
4.0	95	92	90	88	85	82	80	77	75	72	70	67	65	62	60	57	55	52	50
4.5	94	92	89	86	83	80	77	75	72	69	66	63	61	58	55	52	49	46	44
5.0	94	91	88	85	81	78	75	72	69	66	62	59	56	53	50	47	44	41	37
5.5	93	90	86	83	79	76	72	69	66	62	59	55	52	48	45	42	38	35	31
6.0	92	89	85	81	77	74	70	66	62	59	55	51	47	44	40	36	33	29	25
6.5	92	88	84	80	76	72	67	63	59	55	51	47	43	39	35	31	27	23	19
7.0	91	87	82	78	74	69	65	61	56	52	47	43	39	34	30	26	21	17	12
7.5	91	86	81	77	72	67	62	58	53	48	44	39	34	30	25	20	16	11	6
8.0	90	85	80	75	70	65	60	55	50	45	40	35	30	25	20	15	10	5	0

TABLE A6.2 Percent Shear for Measurements Made in Inches

NOTE 1—100 % shear is to be reported when either *A* or *B* is zero.

Dimension <i>B</i> , in.	Dimension <i>A</i> , in.																
	0.05	0.10	0.12	0.14	0.16	0.18	0.20	0.22	0.24	0.26	0.28	0.30	0.32	0.34	0.36	0.38	0.40
0.05	98	96	95	94	94	93	92	91	90	90	89	88	87	86	85	85	84
0.10	96	92	90	89	87	85	84	82	81	79	77	76	74	73	71	69	68
0.12	95	90	88	86	85	83	81	79	77	75	73	71	69	67	65	63	61
0.14	94	89	86	84	82	80	77	75	73	71	68	66	64	62	59	57	55
0.16	94	87	85	82	79	77	74	72	69	67	64	61	59	56	53	51	48
0.18	93	85	83	80	77	74	72	68	65	62	59	56	54	51	48	45	42
0.20	92	84	81	77	74	72	68	65	61	58	55	52	48	45	42	39	36
0.22	91	82	79	75	72	68	65	61	57	54	50	47	43	40	36	33	29
0.24	90	81	77	73	69	65	61	57	54	50	46	42	38	34	30	27	23
0.26	90	79	75	71	67	62	58	54	50	46	41	37	33	29	25	20	16
0.28	89	77	73	68	64	59	55	50	46	41	37	32	28	23	18	14	10
0.30	88	76	71	66	61	56	52	47	42	37	32	27	23	18	13	9	3
0.31	88	75	70	65	60	55	50	45	40	35	30	25	20	18	10	5	0

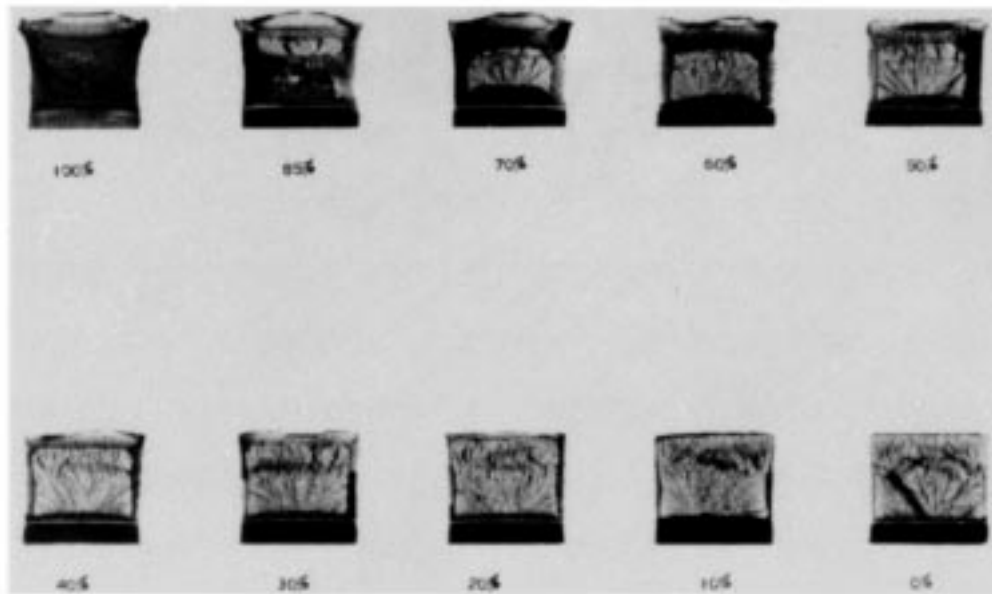

(a) Fracture Appearance Charts and Percent Shear Fracture Comparator

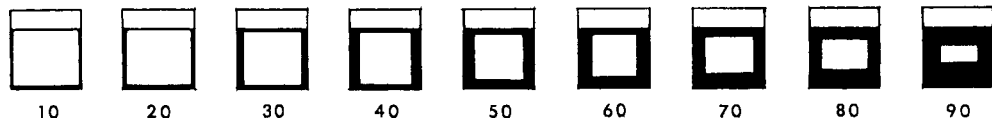

(b) Guide for Estimating Fracture Appearance

FIG. A6.1 Fracture Appearance

APPENDIXES

(Nonmandatory Information)

XI. NOTES ON SIGNIFICANCE OF NOTCHED-BAR IMPACT TESTING

X1.1 Notch Behavior:

X1.1.1 The Charpy V-notch (CVN) impact test has been

used extensively in mechanical testing of steel products, in research, and in procurement specifications for over three

decades. Where correlations with fracture mechanics parameters are available, it is possible to specify CVN toughness values that would ensure elastic-plastic or plastic behavior for fracture of fatigue cracked specimens subjected to minimum operating temperatures and maximum in service rates of loading.

X1.1.2 The notch behavior of the face-centered cubic metals and alloys, a large group of nonferrous materials and the austenitic steels can be judged from their common tensile properties. If they are brittle in tension, they will be brittle when notched, while if they are ductile in tension they will be ductile when notched, except for unusually sharp or deep notches (much more severe than the standard Charpy or Izod specimens). Even low temperatures do not alter this characteristic of these materials. In contrast, the behavior of the ferritic steels under notch conditions cannot be predicted from their properties as revealed by the tension test. For the study of these materials the Charpy and Izod type tests are accordingly very useful. Some metals that display normal ductility in the tension test may nevertheless break in brittle fashion when tested or when used in the notched condition. Notched conditions include constraints to deformation in directions perpendicular to the major stress, or multi axial stresses, and stress concentrations. It is in this field that the Charpy and Izod tests prove useful for determining the susceptibility of a steel to notch-brittle behavior though they cannot be directly used to appraise the serviceability of a structure.

X1.2 *Notch Effect:*

X1.2.1 The notch results in a combination of multi axial stresses associated with restraints to deformation in directions perpendicular to the major stress, and a stress concentration at the base of the notch. A severely notched condition is generally not desirable, and it becomes of real concern in those cases in which it initiates a sudden and complete failure of the brittle type. Some metals can be deformed in a ductile manner even down to very low temperatures, while others may crack. This difference in behavior can be best understood by considering the cohesive strength of a material (or the property that holds it together) and its relation to the yield point. In cases of brittle fracture, the cohesive strength is exceeded before significant plastic deformation occurs and the fracture appears crystalline. In cases of the ductile or shear type of failure, considerable deformation precedes the final fracture and the broken surface appears fibrous instead of crystalline. In intermediate cases, the

fracture comes after a moderate amount of deformation and is part crystalline and part fibrous in appearance.

X1.2.2 When a notched bar is loaded, there is a normal stress across the base of the notch which tends to initiate fracture. The property that keeps it from cleaving, or holds it together, is the “cohesive strength”. The bar fractures when the normal stress exceeds the cohesive strength. When this occurs without the bar deforming it is the condition for brittle fracture.

X1.2.3 In testing, though not in service because of side effects, it happens more commonly that plastic deformation precedes fracture. In addition to the normal stress, the applied load also sets up shear stresses which are about 45° to the normal stress. The elastic behavior terminates as soon as the shear stress exceeds the shear strength of the material and deformation or plastic yielding sets in. This is the condition for ductile failure.

X1.2.4 This behavior, whether brittle or ductile, depends on whether the normal stress exceeds the cohesive strength before the shear stress exceeds the shear strength. Several important facts of notch behavior follow from this. If the notch is made sharper or more drastic, the normal stress at the root of the notch will be increased in relation to the shear stress and the bar will be more prone to brittle fracture (see Table X1.1). Also, as the speed of deformation increases, the shear strength increases and the likelihood of brittle fracture increases. On the other hand, by raising the temperature, leaving the notch and the speed of deformation the same, the shear strength is lowered and ductile behavior is promoted, leading to shear failure.

X1.2.5 Variations in notch dimensions will seriously affect the results of the tests. Tests on E 4340 steel specimens⁶ have shown the effect of dimensional variations on Charpy results (see Table X1.1).

X1.3 *Size Effect:*

X1.3.1 Increasing either the width or the depth of the specimen tends to increase the volume of metal subject to distortion, and by this factor tends to increase the energy absorption when breaking the specimen. However, any increase in size, particularly in width, also tends to increase the degree of constraint and by tending to induce brittle fracture, may decrease the amount of energy absorbed. Where a standard-size specimen is on the verge of brittle fracture, this is particularly true, and a double width specimen may actually require less energy for rupture than one of standard width.

TABLE X1.1 Effect of Varying Notch Dimensions on Standard Specimens

	High-Energy Specimens, J (ft-lbf)	Medium-Energy Specimens, J (ft-lbf)	Low-Energy Specimens, J (ft-lbf)
Specimen with standard dimensions	103.0 ± 5.2 (76.0 ± 3.8)	60.3 ± 3.0 (44.5 ± 2.2)	16.9 ± 1.4 (12.5 ± 1.0)
Depth of notch, 2.13 mm (0.084 in.) ^A	97.9 (72.2)	56.0 (41.3)	15.5 (11.4)
Depth of notch, 2.04 mm (0.0805 in.) ^A	101.8 (75.1)	57.2 (42.2)	16.8 (12.4)
Depth of notch, 1.97 mm (0.0775 in.) ^A	104.1 (76.8)	61.4 (45.3)	17.2 (12.7)
Depth of notch, 1.88 mm (0.074 in.) ^A	107.9 (79.6)	62.4 (46.0)	17.4 (12.8)
Radius at base of notch 0.13 mm (0.005 in.) ^B	98.0 (72.3)	56.5 (41.7)	14.6 (10.8)
Radius at base of notch 0.38 mm (0.015 in.) ^B	108.5 (80.0)	64.3 (47.4)	21.4 (15.8)

^AStandard 2.0 ± 0.025 mm (0.079 ± 0.001 in.).

^BStandard 0.25 ± 0.025 mm (0.010 ± 0.001 in.).

X1.3.2 In studies of such effects where the size of the material precludes the use of the standard specimen, for example when the material is 6.35-mm (0.25-in.) plate, subsize specimens are used. Such specimens (Fig. A3.1) are based on the Type A specimen of Fig. 1.

X1.3.3 General correlation between the energy values obtained with specimens of different size or shape is not feasible, but limited correlations may be established for specification purposes on the basis of special studies of particular materials and particular specimens. On the other hand, in a study of the relative effect of process variations, evaluation by use of some arbitrarily selected specimen with some chosen notch will in most instances place the methods in their proper order.

X1.4 *Temperature Effect:*

X1.4.1 The testing conditions also affect the notch behavior. So pronounced is the effect of temperature on the behavior of steel when notched that comparisons are frequently made by examining specimen fractures and by plotting energy value and fracture appearance versus temperature from tests of notched bars at a series of temperatures. When the test temperature has been carried low enough to start cleavage fracture, there may be an extremely sharp drop in absorbed energy or there may be a relatively gradual falling off toward the lower temperatures. This drop in energy value starts when a specimen begins to exhibit some crystalline appearance in the fracture. The transition temperature at which this embrittling effect takes place varies considerably with the size of the part or test specimen and with the notch geometry.

X1.5 *Testing Machine:*

X1.5.1 The testing machine itself must be sufficiently rigid or tests on high-strength low-energy materials will result in excessive elastic energy losses either upward through the pendulum shaft or downward through the base of the machine. If the anvil supports, the striker, or the machine foundation bolts are not securely fastened, tests on ductile materials in the range from 108 J (80 ft-lbf) may actually indicate values in excess of 122 to 136 J (90 to 100 ft-lbf)

X1.5.2 A problem peculiar to Charpy-type tests occurs when high-strength, low-energy specimens are tested at low temperatures. These specimens may not leave the machine in the direction of the pendulum swing but rather in a sidewise direction. To ensure that the broken halves of the specimens do not rebound off some component of the machine and contact

the pendulum before it completes its swing, modifications may be necessary in older model machines. These modifications differ with machine design. Nevertheless the basic problem is the same in that provisions must be made to prevent rebounding of the fractured specimens into any part of the swinging pendulum. Where design permits, the broken specimens may be deflected out of the sides of the machine and yet in other designs it may be necessary to contain the broken specimens within a certain area until the pendulum passes through the anvils. Some low-energy high-strength steel specimens leave impact machines at speeds in excess of 15.2 m/s (50 ft/s) although they were struck by a pendulum traveling at speeds approximately 5.2 m/s (17 ft/s). If the force exerted on the pendulum by the broken specimens is sufficient, the pendulum will slow down and erroneously high energy values will be recorded. This problem accounts for many of the inconsistencies in Charpy results reported by various investigators within the 14 to 34-J (10 to 25 ft-lb) range. Figure A1.1 illustrates a modification found to be satisfactory in minimizing jamming.

X1.6 *Velocity of Straining:*

X1.6.1 Velocity of straining is likewise a variable that affects the notch behavior of steel. The impact test shows somewhat higher energy absorption values than the static tests above the transition temperature and yet, in some instances, the reverse is true below the transition temperature.

X1.7 *Correlation with Service:*

X1.7.1 While Charpy or Izod tests may not directly predict the ductile or brittle behavior of steel as commonly used in large masses or as components of large structures, these tests can be used as acceptance tests or tests of identity for different lots of the same steel or in choosing between different steels, when correlation with reliable service behavior has been established. It may be necessary to make the tests at properly chosen temperatures other than room temperature. In this, the service temperature or the transition temperature of full-scale specimens does not give the desired transition temperatures for Charpy or Izod tests since the size and notch geometry may be so different. Chemical analysis, tension, and hardness tests may not indicate the influence of some of the important processing factors that affect susceptibility to brittle fracture nor do they comprehend the effect of low temperatures in inducing brittle behavior.

X2. SUGGESTED METHODS OF MEASUREMENT

X2.1 *Position of the Center of Strike Relative to the Center of Gravity:*

X2.1.1 Since the center of strike can only be marked on an assembled machine, only the methods applicable to an assembled machine are described as follows:

X2.1.1.1 The fundamental fact on which all the methods are based is that when the friction forces are negligible, the center of gravity is vertically below the axis of rotation of a pendulum supported by the bearings only, (herein referred to as a free

hanging pendulum). Paragraph A1.3 limits the friction forces in impact machines to a negligible value. The required measurements may be made using specialized instruments such as transits, clinometers, or cathometers. However, simple instruments have been used as described in the following to make measurements of sufficient accuracy.

X2.1.1.2 Suspend a plumb bob from the frame. The plumb line should appear visually to be in the plane of swing of the striking edge.

X2.1.1.3 Place a massive object on the base close to the latch side of the tup. Adjust the position of this object so that when back lighted, a minimal gap is visible between it and the tup when the pendulum is free hanging.

X2.1.1.4 With a scale or depth gage pressed lightly against the striking edge at the center of strike, measure the horizontal distance between the plumb line and striking edge. (The dimension *B* in Fig. X2.1.)

X2.1.1.5 Similarly, measure the distance in a horizontal plane through the axis of rotation from the plumb line to the clamp block or enlarged end of the pendulum stem. (Dimension *A* in Fig. X2.1.)

X2.1.1.6 Use a depth gage to measure the radial distance from the surface contacted in measuring *A* to a machined surface of the shaft which connects the pendulum to the bearings in the machine frame. (Dimension *C* in Fig. X2.1.)

X2.1.1.7 Use an outside caliper or micrometer to measure the diameter of the shaft at the same location contacted in measuring *C*. (Dimension *D* in Fig. X2.1.)

X2.1.1.8 Substitute the measured dimensions in the equation

$$X = A + C + D/2 - B \quad (X2.1)$$

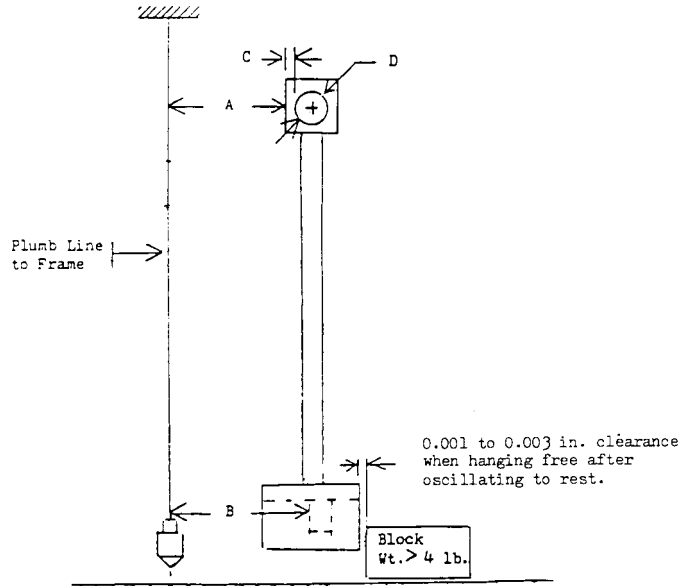

FIG. X2.1 Measurement of Deviation of Center of Strike from Vertical Plane through Axis of Rotation when Pendulum is Hanging Free

where:

X = deviation of the center of strike from a line from the center of rotation through the center of gravity.

X3. CHARPY V-NOTCH VERIFICATION PROGRAM

X3.1 The National Institute of Standards and Technology (NIST) Standard Reference Materials Program (SRMP) conducts a Charpy machine qualification program originally developed by the U.S. Army. Under this program, verification specimens are used to certify Charpy impact machines to the requirements of these test methods.

X3.1.1 Purchasing Verification Specimens:

X3.1.1.1 Verification specimens may be obtained by contacting the SRMP sales office at the National Institute of Standards and Technology.⁸

X3.2 Verification Test Evaluation:

X3.2.1 To receive a written report on verification tests, mail the broken test specimens and questionnaire to: Charpy Pro-

gram Coordinator at NIST.⁹ NIST will evaluate the specimens and test results, and return a report. If a machine meets the direct and indirect verification requirements of ASTM Standard E 23, a letter of certification will be issued for the machine. If a machine is producing values outside the tolerances given in the ASTM E 23 standard, the report may suggest repair or replacement of certain machine parts, a change in testing techniques, or other adjustments.

X3.2.2 Questions on verification testing and results should be addressed to the Charpy Program Coordinator. Test results may be requested by phone or FAX, prior to the evaluation of broken specimens. To obtain informal results, the user must supply the lot code (for example, LL-xx, HH-xx, or SH-xx) and individual specimen identification numbers (stamped on the specimens), along with the absorbed energy values obtained during their test.

⁸ National Institute of Standards and Technology, Standard Reference Material Program, Building 202, Room 204, Gaithersburg, MD 20899. E-mail: srminfo@nist.gov.

⁹ Charpy Program Coordinator, NIST, Mail Code 853, 325 Broadway, Boulder, CO 80303-3328.

REFERENCES

- (1) Nanstad, R. K., Swain, R. L. and Berggren, R. G., "Influence of Thermal Conditioning Media on Charpy Specimen Test Temperature," *Charpy Impact Test: Factors and Variables*, ASTM STP 1072, ASTM, 1990.
- (2) Tobler R. L. Et al., "Charpy Impact Tests Near Absolute Zero," *Journal of Testing and Evaluation*, Vol 19, 1 1992.
- (3) Wullaert, R. A., Ireland, D. R., and Tetelman, A. S., "Radiation Effects on the Metallurgical Fracture Parameters and Fracture Toughness of Pressure Vessel Steels," *Irradiation Effects on Structural Alloys for Nuclear Reactor Applications*, ASTM STP 484, ASTM, 1970, pp. 20–41.
- (4) Sovak, J. F., "Correlation of Data from Standard and Precracked Charpy Specimens with Fracture Toughness Data for HY-130, A517-F, and HY-80 Steel," *Journal of Testing and Evaluation*, JTEVA, Vol 10, No. 3, May 1982, pp. 102–114.
- (5) Succop, G. and Brown, W. F., Jr., "Estimation of K_{Ic} from Slow Bend Precracked Charpy Specimen Strength Ratios," *Developments in Fracture Mechanics Test Methods Standardization*, ASTM STP 632, W. F. Brown, Jr., and J. G. Kaufman, Eds., ASTM, 1977, pp. 179–192.
- (6) Tauscher, S., "The Correlation of Fracture Toughness with Charpy V-notch Impact Test Data," Army Armament Research and Development Command, Technical Report ARLCB-TR-81012, 1981.
- (7) Wullaert, R. A., Ireland, D. R., and A. S. Tetelman, "Use of the Precracked Charpy Specimen in Fracture Toughness Testing," *Fracture Prevention and Control*, pp. 255–282.
- (8) Barsom, J. M. and Rolfe, S. T., "Correlations Between K_{Ic} and Charpy V-notch Test Results in the Transition-Temperature Range," *Impact Testing of Metals*, ASTM STP 466, ASTM, 1970, pp. 281–302.
- (9) Mikalac, S., Vassilaros, M. G., and H. C. Rogers, "Precracking and Strain Rate Effects on HSLA-100 Steel Charpy Specimens," *Charpy Impact Test: Factors and Variables*, ASTM STP 1072, J. M. Holt, Ed., ASTM, 1990.
- (10) Sharkey, R. L. and Stone, D. H., "A Comparison of Charpy V-notch, Dynamic Tear, and Precracked Charpy Impact Transition-Temperature Curves for AAR Grades of Cast Steel."

The American Society for Testing and Materials takes no position respecting the validity of any patent rights asserted in connection with any item mentioned in this standard. Users of this standard are expressly advised that determination of the validity of any such patent rights, and the risk of infringement of such rights, are entirely their own responsibility.

This standard is subject to revision at any time by the responsible technical committee and must be reviewed every five years and if not revised, either reapproved or withdrawn. Your comments are invited either for revision of this standard or for additional standards and should be addressed to ASTM Headquarters. Your comments will receive careful consideration at a meeting of the responsible technical committee, which you may attend. If you feel that your comments have not received a fair hearing you should make your views known to the ASTM Committee on Standards, at the address shown below.

This standard is copyrighted by ASTM, 100 Barr Harbor Drive, PO Box C700, West Conshohocken, PA 19428-2959, United States. Individual reprints (single or multiple copies) of this standard may be obtained by contacting ASTM at the above address or at 610-832-9585 (phone), 610-832-9555 (fax), or service@astm.org (e-mail); or through the ASTM website (www.astm.org).