



Designation: E 338 – 91 (Reapproved 1997)

Standard Test Method of Sharp-Notch Tension Testing of High-Strength Sheet Materials¹

This standard is issued under the fixed designation E 338; the number immediately following the designation indicates the year of original adoption or, in the case of revision, the year of last revision. A number in parentheses indicates the year of last reapproval. A superscript epsilon (ϵ) indicates an editorial change since the last revision or reapproval.

This standard has been approved for use by agencies of the Department of Defense.

1. Scope

1.1 This test method covers the determination of a comparative measure of the resistance of sheet materials to unstable fracture originating from a very sharp stress-concentrator or crack. It relates specifically to fracture under continuously increasing load and excludes conditions of loading that produce creep or fatigue. The quantity determined is the sharp-notch strength of a specimen of particular dimensions, and this value depends upon these dimensions as well as the characteristics of the material. The sharp-notch strength:yield strength ratio is also determined.

1.2 This test method is restricted to one specimen width which is generally suitable for evaluation of high-strength materials (yield strength-to-density ratio above 700 000 psi/lb-in.⁻³ or (18 kgf/mm²)/(g/cm³)). The test will discriminate differences in resistance to unstable fracture when the sharp-notch strength is less than the tensile yield strength. The discrimination increases as the ratio of the notch strength to the yield strength decreases.

1.3 This test method is restricted to sheet materials not less than 0.64 mm (0.025 in.) and not exceeding 6 mm (0.25 in.) in thickness. Since the notch strength may depend on the sheet thickness, comparison of various material conditions must be based on tests of specimens having the same nominal thickness.

1.4 The sharp-notch strength may depend strongly upon temperature within a certain range depending upon the characteristics of the material. The test method is suitable for tests at any appropriate temperature. However, comparisons of various material conditions must be based on tests conducted at the same temperature.

NOTE 1—Further information on background and need for this type of test is given in the first report by the ASTM Committee on Fracture Testing of High-Strength Sheet Materials.²

NOTE 2—The values stated in SI (metric) units are to be regarded as the standard.

¹ This method is under the jurisdiction of ASTM Committee E-8 on Fatigue and Fracture and is the direct responsibility of Subcommittee E08.02 on Standards and Terminology.

Current edition approved Aug. 15, 1991. Published October 1991. Originally published as E 338 – 67. Last previous edition E 338 – 81(86)⁴.

² "Fracture Testing of High-Strength Sheet Materials," *ASTM Bulletin*, ASTBA, No. 243, 1960, pp. 29–40; *ibid.*, No. 244, 1960, pp. 18–28.

1.5 *This standard does not purport to address all of the safety concerns, if any, associated with its use. It is the responsibility of the user of this standard to establish appropriate safety and health practices and determine the applicability of regulatory limitations prior to use.*

2. Referenced Documents

2.1 ASTM Standards:

- E 4 Practices for Force Verification of Testing Machines³
- E 8 Test Methods for Tension Test of Metallic Materials³
- E 602 Test Method for Sharp-Notch Tension Testing with Cylindrical Specimens³
- E 616 Terminology Relating to Fracture Testing³

3. Terminology

3.1 Definitions:

3.1.1 *crack strength*, σ_c [FL⁻²]*—*the maximum value of the nominal (net-section) stress that a cracked specimen is capable of sustaining.

3.1.1.1 *Discussion—*See definition of **nominal (net-section) stress** in Terminology E 616.

3.1.1.2 *Discussion—*Crack strength is calculated on the basis of the maximum load and the original minimum cross-sectional area (net cross section or ligament). Thus, it takes into account the original size of the crack, but ignores any crack extension that may occur during the test.

3.1.1.3 *Discussion—*Crack strength is analogous to the ultimate tensile strength, as it is based on the ratio of the maximum load to the minimum cross-sectional area of the specimen at the start of the test.

3.1.2 *sharp-notch strength*, σ_s [FL⁻²]*—*the maximum nominal (net-section) stress that a sharply notched specimen is capable of sustaining.

3.1.2.1 *Discussion—*See definition of **nominal (net-section) stress** in Terminology E 616.

3.1.2.2 *Discussion—*Values of sharp-notch strength may depend on notch and specimen configuration as these affect the net cross section and the elastic stress concentration.

3.1.2.3 *Discussion—*The tension specimens used in Test Method E 602 and this test method have notch root radii that

³ *Annual Book of ASTM Standards*, Vol 03.01.

approach the limit of machining capability. For these specimens, the radius is believed to be small enough that any smaller radius that is obtainable by standard machining methods would not produce changes, in notch strength, that are significant from an engineering viewpoint.

3.1.2.4 *Discussion*—In these test methods, the notch root radii are very small (approaching the limit for machining capability), and values of sharp-notch strength may depend on notch root radius. See definition of **notch tensile strength** in Terminology E 616.

4. Significance and Use

4.1 The test method provides a comparative measure of the resistance of sheet materials to unstable fracture originating from the presence of cracks or crack-like stress concentrators. It is not intended to provide an absolute measure of resistance to crack propagation which might be used in calculations of the strength of structures. However, it can serve the following purposes:

4.1.1 In research and development of materials, to study the effects of the variables of composition, processing, heat-treatment, etc.;

4.1.2 In service evaluation, to compare the relative crack-propagation resistance of a number of materials which are otherwise equally suitable for an application, or to eliminate materials when an arbitrary minimum acceptable sharp-notch strength can be established on the basis of service performance correlation, or some other adequate basis;

4.1.3 For specifications of acceptance and manufacturing quality control when there is a sound basis for establishing a minimum acceptable sharp-notch strength. Detailed discussion of the basis for setting a minimum in a particular case is beyond the scope of this method.

4.2 The sharp-notch strength may decrease rapidly through a narrow range of decreasing temperature. This temperature range and the rate of decrease depend on the material and its thickness. The temperature of the specimen during each test shall therefore be controlled and recorded. Tests shall be conducted throughout the range of expected service temperatures to ascertain the relation between notch strength and temperature. Care shall be taken that the lowest and highest anticipated service temperatures are included.

4.3 Limited results suggest that the sharp-notch strengths of stable high-strength steels are not appreciably sensitive to rate of loading within the range of loading rates normally used in conventional tension tests. Where very low or high rates of loading are expected in service, the effect of loading rate should be investigated using special procedures that are beyond the scope of this method.

4.4 The precision of sharp-notch strength measurement should be equivalent to that of the ordinary tensile strength of a sheet specimen since both depend upon measurements of load and of dimensions of comparable magnitude. However, the sharp-notch strength is more sensitive to local flaws than the tensile strength and normally shows more scatter. The influence of this scatter should be reduced by testing duplicate specimens and averaging the results.

5. Apparatus

5.1 The test shall be conducted with a tension testing machine that conforms to the requirements of Practices E 4.

5.2 The devices for transmitting load to the specimen shall be such that the major axis of the specimen coincides with the load axis. A satisfactory arrangement incorporates clevises carrying hardened pins which pass through holes in the ends of the specimen, the diameter of the pins being only slightly smaller than that of the holes. Spacing washers of the necessary thickness shall be used to center the specimen in the clevises. A typical arrangement is shown in Fig. 1.

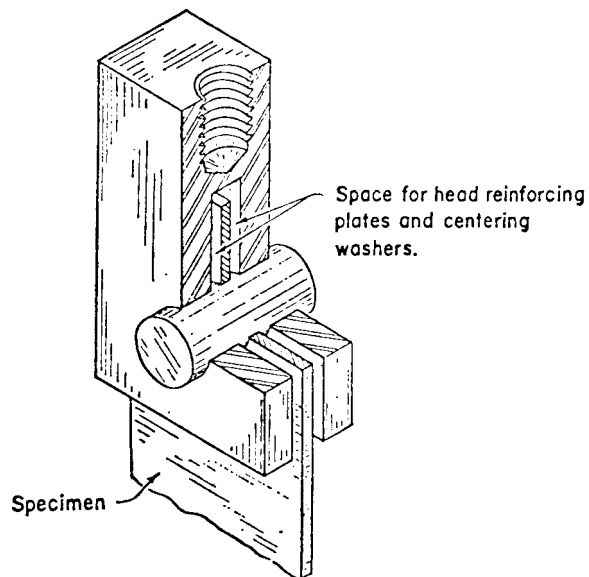
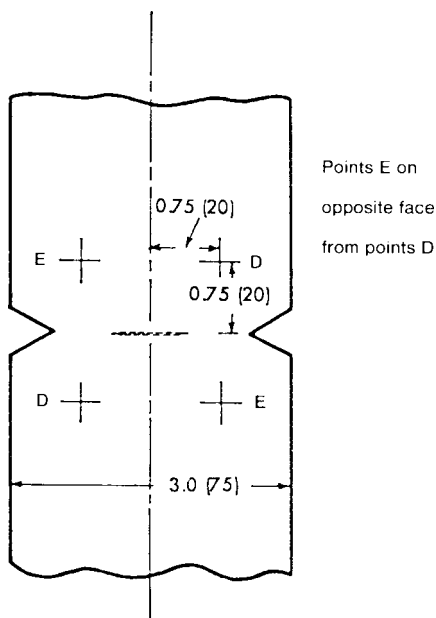

FIG. 1 Specimen Loading Clevis with Hardened Pin

5.3 *Temperature Control*—For the tests at other than room temperature, any suitable means may be used to heat or cool the specimen and to maintain a uniform temperature over the region that includes the notch or crack. The ability of the equipment to provide a region of uniform temperature shall be established by measurements of the temperature at positions on both faces of a specimen as shown in Fig. 2. The temperature surveys shall be conducted either at each temperature level at which tests are to be made, or at a series of temperature levels at intervals of 30°C (50°F) over the range of test temperatures. The test temperature shall be held within $\pm 1\frac{1}{2}$ °C ($\pm 2\frac{1}{2}$ °F) during the course of the test. At the test temperature the difference between the indicated temperatures at any two of the four thermocouple positions shall not exceed 3°C (5°F).

NOTE 3—A convenient means of heating or cooling flat specimens consists of a pair of flat copper or brass plates which contact the surfaces of the specimen. The plates are fitted with heating or cooling devices designed to maintain uniformity of temperature of the contact surfaces. Thermocouples may be permanently incorporated with their junctions at the contact surfaces. Such devices have been found convenient and reliable for temperatures from that of liquid nitrogen to at least 330°C (600°F).⁴ The use of liquid baths for heating specimens shall be avoided unless it can be established that the liquid has no effect on the sharp-notch strength of the material.

⁴ Srawley, J. E., and Beachem, C. D., *NRL Report 5127*, NRLRA, April 9, 1958.



NOTE 1—Dimensions in inches with millimetre dimensions in parentheses.

FIG. 2 Positions of Thermocouple Junctions for Temperature Surveys

5.4 *Temperature Measurement*—The temperature of the specimen during any test at other than room temperature shall be measured at one, or preferably more than one, of the positions shown in Fig. 2. The junctions of the thermocouples shall be in good thermal contact with the specimen. The thermocouples and measuring instruments shall be calibrated and shall not exceed 3°C (5°F).

6. Test Specimens

6.1 Suggested designs for a standard 75-mm (3-in.) wide machined sharp edge-notch test specimen, DE(T), and a fatigue center-crack specimen, M(T), are shown in Fig. 3 and Fig. 4. The dimensions of the notched or cracked regions shall be as

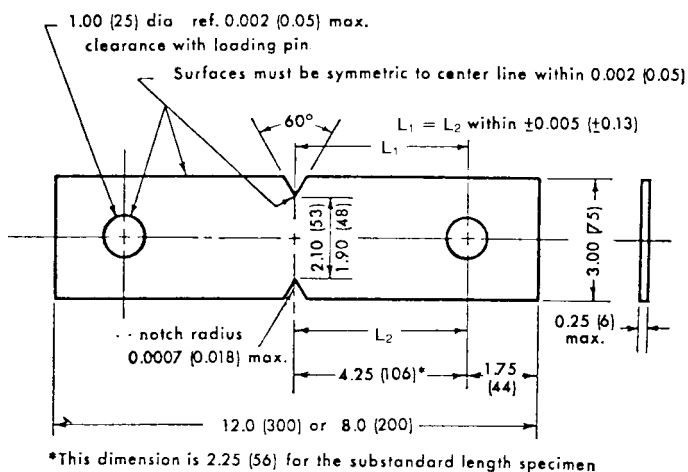

NOTE 1—Dimensions in inches with millimetre dimensions in parentheses.

FIG. 3 Machined Sharp Edge-Notch Specimen, DE(T)

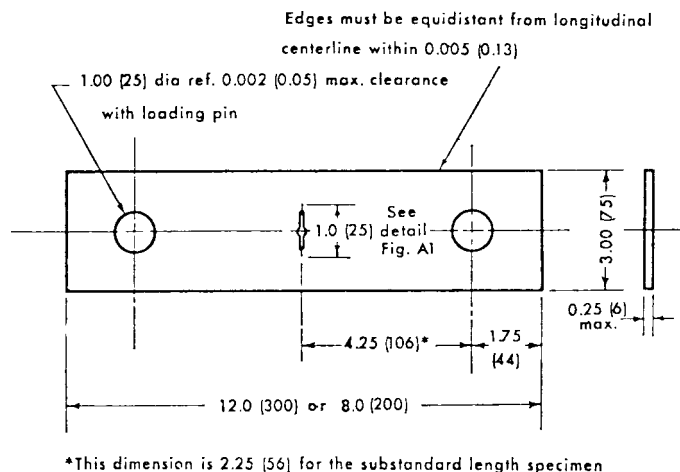

NOTE 1—Dimensions in inches with millimetre dimensions in parentheses.

FIG. 4 Fatigue Center-Crack Specimen M(T)

indicated and pin loading shall be used. It will be noted that the length of the standard specimen is specified as 300 mm (12 in.) with the provision that, where unavoidable due to material limitations, a substandard length (200 mm, 8 in.) specimen may be used. However, for identical test conditions on the same material the 8-in. specimen will give a different strength value than the standard specimen. For this reason comparisons of various material conditions must be based on tests conducted with the same length specimen. Specimens with parallel sides are shown, and these will fracture in the notched section for the great majority of materials. However, for exceptionally tough conditions where the notch strength exceeds the yield strength, fracture may occur at the pin hole unless suitable head reinforcing plates are provided. A suggested design for such plates is shown in Fig. 5. One plate is used on each side of the specimen heads, and loads are transmitted to the plates by three

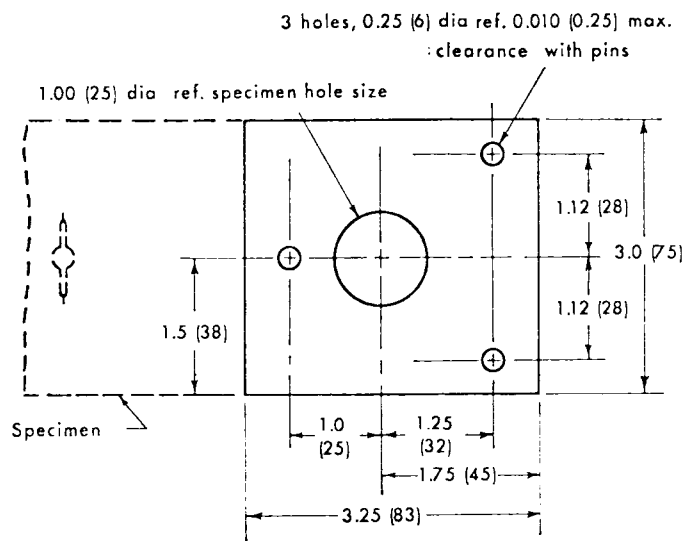

NOTE 1—Dimensions in inches with millimetre dimensions in parentheses.

FIG. 5 Reinforcing Plate for Specimen Head

hardened 6-mm (1/4-in.) diameter pins having a length that will permit them to enter the slot in the loading clevises (see Fig. 1). If the plates are 3 mm (1/8 in.) thick and made of a material having a 1380-MPa (200 000-psi) minimum yield strength, they may be used in any test covered by this method.

6.2 The sharpness of the machined notches is a critical feature of the sharp edge-notched specimen, DE(T), of Fig. 3 and special care is required to prepare them.⁵ Finish machining of the notch may be completed either before or after final heat treatment. For each specimen the notch root radii and notch location with respect to the pin-hole centers shall be measured prior to testing, and specimens that do not meet the requirements of Fig. 3 shall be discarded or reworked.

6.3 Center-cracked specimens having high notch acuity have been prepared by machining with sharp tools and by electric discharge methods. However, fatigue cracking of a prenotched sample is preferred and shall be used in this test method. The production of fatigue cracks requires the machining of a suitable crack starter (see Appendix X1). A preferred technique for generating the fatigue cracks is given in Appendix X2. Fatigue cracking may be done either before or after full heat treatment. Specimens that do not meet the requirements of Fig. 4 shall be discarded.

7. Procedure

7.1 *Dimensions*—Measure the thickness, B , to the nearest 0.013 mm (0.0005 in.) at not less than three positions between the machined notches or between the crack tips and specimen edge, and record the average value. If the variation in thickness about the average is greater than $\pm 2\%$ record a survey of the thickness. Measure the distance between notch roots of specimen DE(T), the net section width, to the nearest 0.25 mm (0.01 in.) and the notch root radii to the nearest 0.006 mm (0.00025 in.), and record. In the case of specimen M(T), measure the width of the specimen before testing to the nearest 0.025 mm (0.001 in.) and record, and measure the over-all crack length, from the most advanced point of one fatigue crack to the most advanced point of the other, after testing to the nearest 0.025 mm (0.001 in.), and record. The width minus the over-all crack length is the net section width.

7.2 *Testing*—Conduct the test in a similar manner to that of an ordinary tension specimen except that no extensometer is required. It is recommended that a suitable lubricant, such as MoS₂, be used on the loading pins and on the spherical seat in the heads of the tension testing machine to assist in alignment. No staining fluids shall be introduced into the notches or cracks in order to define slow crack extension, unless it has been proven that the substance used will not influence the notch strength. The speed of testing shall be such that the rate of increase of nominal stress on the notched or cracked section shall not exceed 690 MPa (100 000 psi)/min at any stage of the test. Record the maximum load, P , reached during the test, to the smallest change of load which can be estimated.

7.3 *Sharp-Notch Strength*—Calculate the sharp-notch strength as $P/(B \times \text{net section width})$.

7.4 *Fracture Appearance*—The appearance of the fracture is valuable subsidiary information and shall be briefly noted for each specimen. One common type of fracture is shown in Fig. 6(a). This consists of a central flat band, transverse to the specimen axis, and bordered by relatively narrow oblique bands. If the oblique bands are fairly uniform, measure the average width, b , of the transverse band and record the ratio $(B - b)/B$ as the proportion of oblique fracture per unit thickness, or *oblique fraction*. In the case of test specimen DE(T), the measurement b shall be at a point within the middle third of the specimen width. For specimen M(T), make measurements on each side of the center slot at points not closer than one plate thickness to the edge nor farther than 8 mm (5/16 in.) from the edge. Average these measurements to obtain the oblique fraction. Generally, this fraction cannot be determined to better than the nearest 0.05 for either specimen. If the oblique borders are comparatively broad they will generally be irregular, as in Fig. 6(b). The fracture appearance may then be recorded as “Predominantly Oblique.” If the flat transverse fracture is confined to well-defined triangular regions at the notch roots, as in Fig. 6(c), the fracture appearance may be recorded as “Full Oblique.” In some cases the fracture appearance does not correspond with these classifications. For instance, fractures having a rough laminated appearance sometimes occur. In such cases a short descriptive notation such as “Laminated” may be recorded. Typically, the fracture appearance and the sharp-notch strength will undergo concomitant changes with variation in some parameter such as test temperature, thickness, or a heat-treatment variable. There is often a quite abrupt increase in sharp-notch strength as fracture appearance changes from predominantly transverse to full oblique over a restricted range of the parameter.

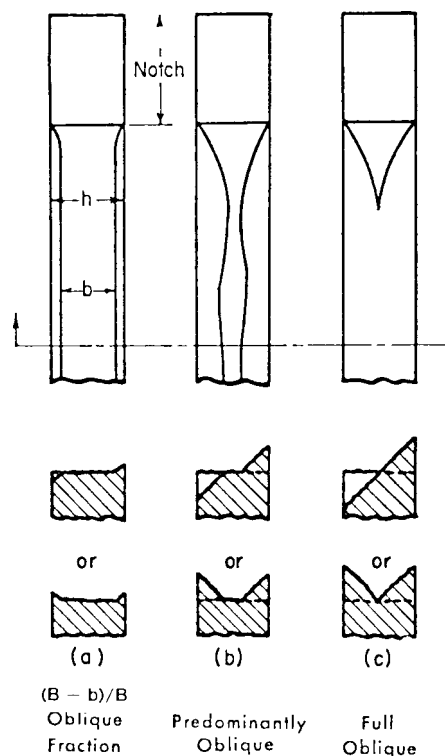

FIG. 6 Common Types of Fracture Appearance

⁵ March, J. L., Ruprecht, W. J., and Reed, George, “Machining of Notched Tension Test Specimens,” *ASTM Bulletin*, ASTBA, No. 244, 1960, pp. 52-55.

ASTM E 338

7.5 *Sharp-Notch Strength/Yield Strength Ratio*—The ratio of sharp-notch strength to tensile yield strength is of significance. Prepare standard tension test specimens (see Section 4 of Test Methods E 8) of the same stock and process together with the sharp-notch specimens so that this ratio can be determined without ambiguity in relation to the processing of the material.

8. Report

8.1 At least two sharp edge-notched or fatigue center-cracked specimens shall be tested for each distinct set of values of the controlled variables (material factors, thickness, temperature). For the purpose of calculating the sharp-notch strength/yield strength ratio at other than room temperature, the yield strength may be interpolated from values at temperatures not more than 50°C (100°F) above and below the temperature at which the sharp notch test is performed.

8.2 The report shall include the following information for each sharp-notch specimen tested: type of specimen (DE(T) or M(T)), length, thickness, width, notch depth or crack length,

notch root radii, temperature, maximum load, oblique fraction, and sharp-notch strength. The tensile ultimate and yield strength corresponding to each set of controlled variables used for the notch test should also be reported along with the sharp-notch strength/yield strength ratio.

9. Precision and Bias

9.1 *Precision*—It is not practicable to specify the precision of the procedure in Test Method E 338 for measuring sharp-notch strength as the available data are not of a type that permits a meaningful analysis.

9.2 *Bias*—There is no accepted “standard” value for the sharp-notch strength of any material. In the absence of such a true value, no meaningful statement can be made concerning bias of data.

10. Keywords

10.1 crack strength; high strength materials; sharp-notch strength; sharp-notch strength/yield strength ratio; sharp-notch tension test; sheet specimens

APPENDIXES

(Nonmandatory Information)

X1. FATIGUE CRACK STARTER

X1.1 Various types of crack starters may be employed provided they have a sufficiently high stress concentration to produce fatigue cracks in a reasonable number of cycles at the nominal stress level specified below, and provided the fatigue crack extension is sufficient to avoid the stress field produced by the starter tip. A tip width of 0.2 mm (0.008 in.) maximum at the end of a 18-mm (0.7-in.) long starter will provide a sufficiently high stress concentration. Fatigue crack extension from each tip should be at least twice the tip width. Fig. X1.1

shows a suggested design for the crack starter consisting of a 6-mm (0.25-in.) center hole extended by saw cuts terminated in narrow slots having a maximum width of 0.2 mm (0.008 in.). In many materials the narrow slots can be produced by a jeweler’s saw. A narrower slot can be produced by electrical discharge machining methods. Alternative crack starter designs may be used but must lie within the envelope defined by the 30° included angles having their apexes at the ends of the fatigue cracks.

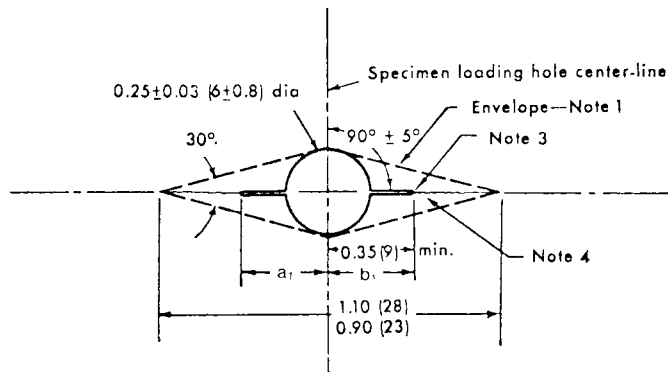

- NOTE 1—Starter slot configuration must lie within the envelope that has its apexes at the end of the fatigue cracks.
- NOTE 2— $a_1 = b_1$ within 0.25 mm (0.010 in.).
- NOTE 3—Maximum width of crack starter slot at its tip = 0.2 mm (0.008 in.).
- NOTE 4—Fatigue crack must extend from each crack starter slot a distance of at least two times the slot tip width.
- NOTE 5—Dimensions in inches with millimetre dimensions in parentheses.

FIG. X1.1 Suggested Design for Center Fatigue Crack Starter



X2. PRODUCTION OF FATIGUE CRACKS

X2.1 Fatigue cracks at the starter tips shall be produced by cyclic tension-tension stressing, pin loading in the same manner as used in tension testing. Again lubrication of the pins with MoS₂ is recommended to minimize any tendency for cracking at the pin holes. The minimum and maximum loads should be selected by experience so that fatigue crack extension can be readily observed and controlled. The nominal net

stress at the maximum load may be typically 10 to 40 % and should not exceed 50 % of the yield strength. If the maximum tension stress is excessive, post fracture examination may reveal the fatigue crack obviously does not lie in a plane perpendicular to the specimen surface. In such cases the test result should be discarded.

The American Society for Testing and Materials takes no position respecting the validity of any patent rights asserted in connection with any item mentioned in this standard. Users of this standard are expressly advised that determination of the validity of any such patent rights, and the risk of infringement of such rights, are entirely their own responsibility.

This standard is subject to revision at any time by the responsible technical committee and must be reviewed every five years and if not revised, either reapproved or withdrawn. Your comments are invited either for revision of this standard or for additional standards and should be addressed to ASTM Headquarters. Your comments will receive careful consideration at a meeting of the responsible technical committee, which you may attend. If you feel that your comments have not received a fair hearing you should make your views known to the ASTM Committee on Standards, at the address shown below.

This standard is copyrighted by ASTM, 100 Barr Harbor Drive, PO Box C700, West Conshohocken, PA 19428-2959, United States. Individual reprints (single or multiple copies) of this standard may be obtained by contacting ASTM at the above address or at 610-832-9585 (phone), 610-832-9555 (fax), or service@astm.org (e-mail); or through the ASTM website (www.astm.org).