

This document is not an ASTM standard and is intended only to provide the user of an ASTM standard an indication of what changes have been made to the previous version. Because it may not be technically possible to adequately depict all changes accurately, ASTM recommends that users consult prior editions as appropriate. In all cases only the current version of the standard as published by ASTM is to be considered the official document.



---

**Designation: E 436 – 91 (Reapproved 1997)**



**Designation: E 436 – 03**

## Standard Test Method for Drop-Weight Tear Tests of Ferritic Steels<sup>1</sup>

This standard is issued under the fixed designation E 436; the number immediately following the designation indicates the year of original adoption or, in the case of revision, the year of last revision. A number in parentheses indicates the year of last reapproval. A superscript epsilon ( $\epsilon$ ) indicates an editorial change since the last revision or reapproval.

<sup>1</sup> This method is under the jurisdiction of ASTM Committee E-8 E08 on Fatigue and Fracture and is the direct responsibility of Subcommittee E08.02 on Standards and Terminology.

Current edition approved Aug. 15, 1991; May 10, 2003. Published October 1991; June 2003. Originally published as E 436 – 71 T, approved in 1971. Last previous edition approved 1997 as E 436 – 74(1986); 91(1997).

### 1. Scope

1.1 This test method covers drop-weight tear tests (DWTT) on ferritic steels with thicknesses between 3.18 and 19.1 mm (0.125 and 0.750 in.).

1.2 The values stated in SI (metric) units are to be regarded as the standard.

1.3 *This standard does not purport to address all of the safety concerns, if any, associated with its use. It is the responsibility of the user of this standard to establish appropriate safety and health practices and determine the applicability of regulatory limitations prior to use.*

### 2. Referenced Documents

2.1 *ASTM Standards:*

E 208 Test Method for Conducting Drop-Weight Test to Determine Nil-Ductility Transition Temperature of Ferritic Steels<sup>2</sup>

E 1823 Terminology Relating to Fatigue and Fracture Testing<sup>2</sup>

### 3. Significance and Use

3.1 This test method can be used to determine the appearance of propagating fractures in plain carbon or low-alloy pipe steels (yield strengths less than 825 MPa or 120 000 psi) over the temperature range where the fracture mode changes from brittle (cleavage or flat) to ductile (shear or oblique).

3.2 This test method can serve the following purposes:

3.2.1 For research and development, to study the effect of metallurgical variables such as composition or heat treatment, or of fabricating operations such as welding or forming on the mode of fracture propagation.

3.2.2 For evaluation of materials for service to indicate the suitability of a material for specific applications by indicating fracture propagation behavior at the service temperature(s).

3.2.3 For information or specification purposes, to provide a manufacturing quality control only when suitable correlations have been established with service behavior.

### 4. Apparatus

4.1 The testing machine shall be either a pendulum type or a vertical-dropped-weight (Note 1) type. The machine shall provide sufficient energy to completely fracture a specimen in one impact.

4.1.1 As a guide in the design of the equipment it has been found that up to 2712 J (2000 ft-lbf) of energy may be required to completely fracture specimens of steel up to 12.7 mm (½ in.) in thickness with tensile strengths to 690 MPa (100 000 psi).

NOTE 1—Equipment of the vertical-dropped-weight variety that can be readily modified to conduct the drop-weight tear test is described in Test Method E 208.

NOTE 2—Current pipeline grade steels take more than 4kJ at design temperature of -5°C

4.2 The specimen shall be supported in a suitable manner to prevent sidewise rotation of the specimen.

4.3 The velocity of the hammer (in either type of testing machine) shall be not less than 4.88 m/s (16 ft/s).

### 5. Test Specimen

5.1 The test specimen shall be a 76.2 by 305-mm (3 by 12-in.) by full-plate-thickness edge-notch bend specimen employing a pressed notch. Fig. 1 presents the dimensions and tolerances of the specimens. The specimens shall be removed from the material

<sup>2</sup> Annual Book of ASTM Standards, Vol 03.01.

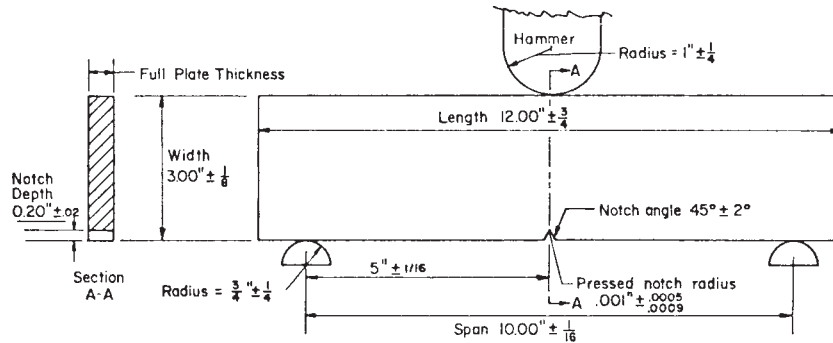

FIG. 1 Drop-Weight Tear Test Specimens and Support Dimensions and Tolerances (for Specimens 1/8 to 3/4 in. in Thickness)

under test by sawing, shearing, or flame cutting, with or without machining.

NOTE 23—If the specimen is flame cut it is usually difficult to press in the notch unless the heat-affected zone is removed by machining.

5.2 The notch shall be pressed to the depth shown in Fig. 1 with a sharp tool-steel chisel with an included angle of  $45 \pm 2^\circ$ . Machined notches are prohibited.

NOTE 34—The notch radius obtained with a sharp tool-steel chisel is normally between 0.013 to 0.025 mm (0.0005 to 0.001 in.). When many specimens are to be tested, it is helpful to use a jig that will guide the chisel and stop it at the proper depth.

## 6. Procedure

6.1 In the temperature range from  $-73$  to  $100^\circ\text{C}$  ( $-100$  to  $+212^\circ\text{F}$ ) employ the procedure described in 6.1.1 and 6.1.2.

6.1.1 Completely immerse the specimens in a bath of suitable liquid at a temperature within  $\pm 1^\circ\text{C}$  ( $\pm 2^\circ\text{F}$ ) of the desired test temperature for a minimum time of 15 min prior to testing. Separate the specimens by a distance at least equal to the thickness of the specimen. Make provision for circulation of the bath to assure uniform bath temperature.

NOTE 45—Alternatively, other methods of heating and cooling may be used, provided they produce equivalent time at temperature of the specimens.

6.1.2 Remove the specimens from the bath and break as described herein within a time period of 10 s. If the specimens are held out of the bath longer than 10 s return them unbroken to the bath for a minimum of 10 min. Do not handle the specimen in the vicinity of the notch by devices the temperature of which is appreciably different from the test temperature.

6.2 For temperatures outside of the range specified in 6.1 maintain the specimen temperature at the time of impact within  $4^\circ\text{C}$  ( $\pm 2^\circ\text{F}$ ) of the desired test temperature.

6.3 Insert the specimen in the testing machine so that the notch in the specimen lines up with the centerline of the tup on the hammer within 1.59 mm ( $1/16$  in.). Also, center the notch in the specimen between the supports on the anvil.

6.4 Consider tests invalid if the specimen buckles during impact.

NOTE 56—Buckling has been experienced with specimen thicknesses less than 4.75 mm (0.187 in.).

## 7. Specimen Evaluation

7.1 For the purposes of this method, shear-fracture surfaces shall be considered as those having a dull gray silky appearance which are commonly inclined at an angle to the specimen surface. Cleavage or brittle fractures shall be considered those that are bright and crystalline in appearance and that are perpendicular to the plate surface. The cleavage fractures generally extend from the root of the notch and are surrounded by a region of shear or shear lips on the specimen surface.

7.2 Evaluate the specimens (Note-6) 7) by determining the percent shear area of the fracture surface neglecting the fracture surface for a distance of one specimen thickness from the root of the notch and the fracture surface for a distance of one specimen thickness from the edge struck by the hammer. Fig. 2 illustrates in the cross-hatched area that portion of the fracture surface to be considered in the evaluation of the percent shear area of the fracture surface.

NOTE 67—If the specimens are to be preserved for some length of time after evaluation of the shear area or if a considerable time elapses between testing and evaluation, the fracture surfaces should be treated to keep them from corroding.

7.3 Occasionally specimens will exhibit the fracture appearance shown in Fig. 3. On specimens of this type the fracture appears to have stopped and started a number of times exhibiting intermittent regions of shear and cleavage in the midthickness portion

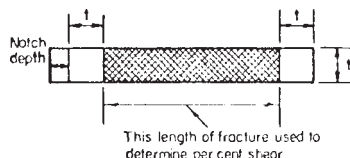
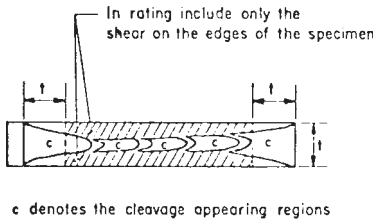

FIG. 2 Fracture Surface Included in Shear-Area Determination



**FIG. 3 Alternative Shear-Cleavage Fracture Appearance**

of the specimen. The shear area included in the rating of specimens of this type shall be that shown in the cross-hatched area of Fig. 3 (neglect the shear areas in the region of intermittent shear and cleavage fracture in rating the specimen).

7.4 For referee method of determining the percent shear area of the fracture surface, measure the cleavage area of the fracture surface with a planimeter on a photograph or optical projection of the fracture surface. Then divide the cleavage area by the net area of the specimen included in the rating, express as percent, and subtract from 100. Alternative methods more adaptable to routine rating are described in 7.4.1-7.4.3.

7.4.1 The percent shear area can be evaluated by comparing the fracture surfaces with a calibrated set of photographs of previously fractured specimens or with actual specimens of calibrated percent shear areas for a specific thickness. Calibrate in accordance with 7.4.

7.4.2 The percent shear area can be evaluated with the procedure described in Annex A1.

7.4.3 The percent shear area can be evaluated with any other procedure that has been demonstrated to produce results equivalent to those obtained in 7.4.

7.5 Fig. 4 shows five DWTT specimens that have been tested over the temperature range from  $-17$  to  $16^{\circ}\text{C}$  ( $0$  to  $60^{\circ}\text{F}$ ). The bright regions of the fracture are the cleavage fracture areas and the darker gray regions are the areas of shear fracture. (Note that the specimen tested at  $4^{\circ}\text{C}$  ( $40^{\circ}\text{F}$ ) has almost 100 % shear area and it has a fracture surface that in section has shear lips on each surface with a region of flat fibrous shear at the midthickness (see Section A-A of Fig. A1.1(a)). This fracture appearance is typical of a full shear fracture and is easily distinguished from the flat cleavage fracture in the center of the specimen with shear lips at the specimen surfaces.

## 8. Report

8.1 A report of the test results shall be furnished to the purchaser and shall include as a minimum the specimen orientation in product (transverse or longitudinal), thickness, heat number, material specification, test temperature, and the fracture appearance (percent shear area) of each specimen. If a series of specimens is broken over a range of temperatures, a plot of the results as percent shear area versus temperature is desirable.

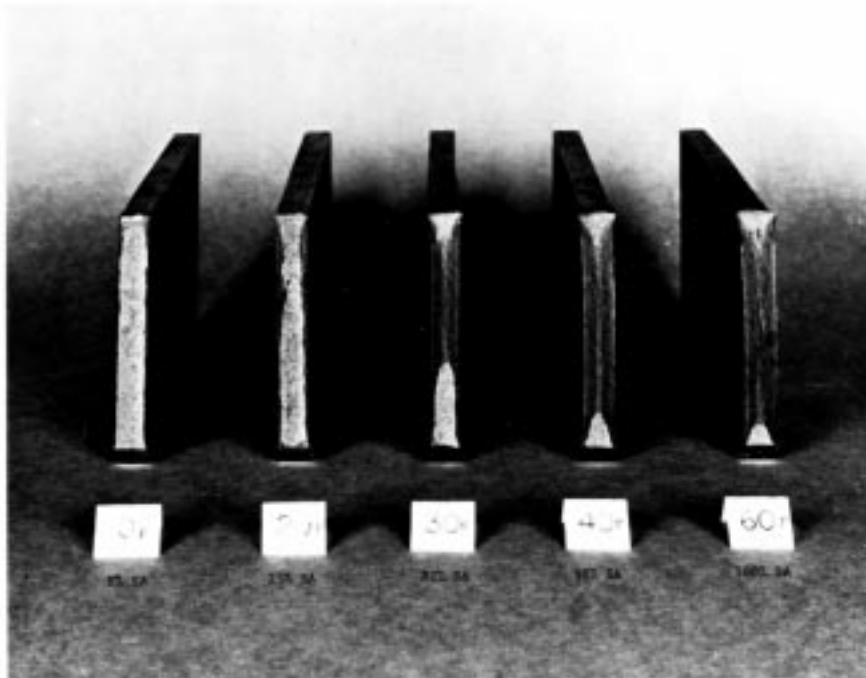

**FIG. 4 DWTT Fracture Appearances**

**9. Precision and Bias**

9.1 *Precision*—It is not practicable to specify the precision of the procedure in Test Method E 436 for measuring the fracture appearance (percent shear area) as the available data are not of a type that permits a meaningful analysis.

9.2 *Bias*—There is no accepted “standard” value for the percent shear area of any material. In the absence of such a true value, no meaningful statement can be made concerning bias of data.

**10. Keywords**

10.1 brittle fracture; drop-weight tear test; ferritic steels; fracture appearance; impact loading; percent shear area

ANNEXES

(Mandatory Information)

A1. PROCEDURE FOR MEASUREMENT OF DWTT PERCENT SHEAR AREA

A1.1 Many ways have been suggested and tried for measuring the percent shear of DWTT specimens. Some of the methods such as photographing and planimetering the fracture are accurate but slow; other methods such as measuring the shear at the midpoint of the specimen are rapid but not accurate enough. The procedure outlined herein has been developed over a period of time as a reasonably accurate and rapid method of measuring the percent shear area.

A1.2 It has been found that the procedure to be used depends upon the configuration of the fracture surface. Fig. A1.1 shows three representative fracture surfaces. On specimens exhibiting fracture surfaces between Fig. A1.1(a) and Fig. A1.1(b) the shear area is calculated assuming the cleavage portion of the fracture is a third-degree curve—this approximates the cleavage fracture surface configuration with reasonable accuracy.<sup>3</sup> The procedure for this specimen appearance is to measure the length of the cleavage fracture in between the two “t” lines (*B* dimensions in Fig. A1.2 and Fig. A1.3) and the width of the cleavage fracture at the one “t” line beneath the notch. From these dimensions the area of the cleavage portion of the fracture surface can be calculated as  $\frac{3}{4} AB$ . Subtracting this from the net area of the fracture surface and dividing the result by the net area of the fracture surface results in the percent shear area when multiplied by 100. This procedure results in the following equation which is applicable between approximately 45 and 100 % shear or to the point where the cleavage fracture extends to the one “t” line on the back end of the specimen.

$$(A1.1) \quad \%SA = \frac{AB - \frac{3}{4}AB}{AB} \times 100$$

*AB*

$$(A1.1) \quad \%SA = \frac{AB - \frac{3}{4}AB}{AB} \times 100$$

$$AB(2.8 - 2t) \times 100$$

where:

%SA = percent shear area,

*A* = the width of the cleavage fracture at the one “t” line beneath the notch, in., and

*B* = the length of the cleavage fracture in between the two “t” lines, in.

A1.3 Rather than make the calculation for each specimen it is quicker to compute the data for various thicknesses. Fig. A1.2 and Fig. A1.3 are examples of plots for determining percent shear of 0.312 and 0.344-in.-thick material. With figures such as these it is possible to determine shear areas of specimens by measuring the *A* and *B* dimensions of the fracture surfaces for shear areas in the range from 45 to 100 %.

<sup>3</sup> Symposium on Line Pipe Research, L30000, American Gas Assn., New York, NY, 1965, pp. 83–118.

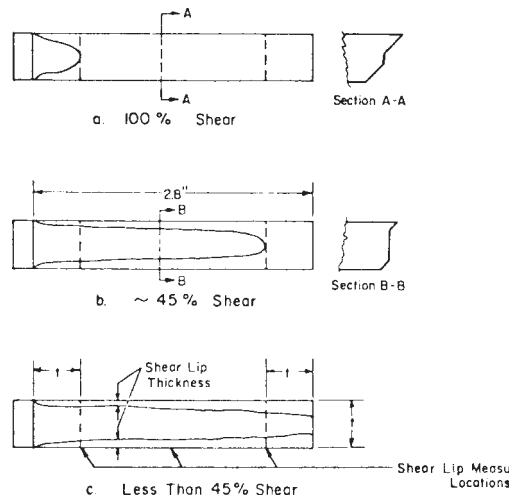

FIG. A1.1 Representative DWTT Fracture Surfaces

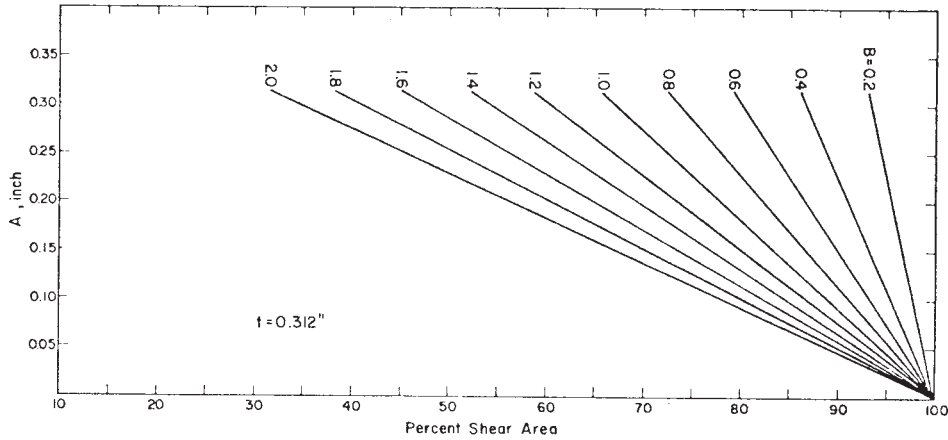
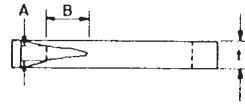

FIG. A1.2 Chart for Determining Percent Shear for 0.312-in. Material

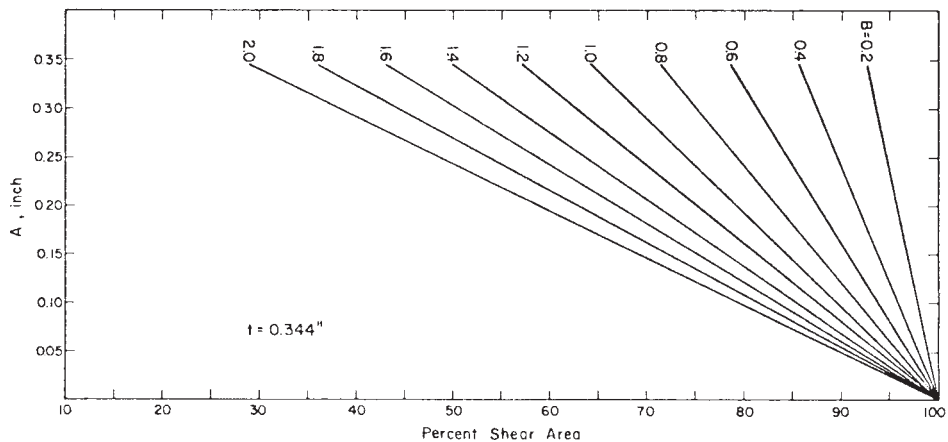
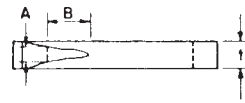

FIG. A1.3 Chart for Determining Percent Shear for 0.344-in. Material

A1.4 In the shear range between 0 and 45 %, represented by the fracture surface shown in Fig. A1.1(c), to obtain the percent shear make three measurements of the total shear lip thicknesses (include both shear lips) between the one “t” lines as shown in Fig. A1.1(c), average them and divide by the specimen thickness. Convert the results to percent by multiplying by 100. The shear lip thicknesses versus percent shear for a specific plate thickness may be tabulated for ease of determination.

## A2. INTERPRETATION OF DROP-WEIGHT TEAR TEST RESULTS

A2.1 Considerable research has been conducted on the significance of the drop-weight tear test (DWTT) results. Included in this test method is a list of selected references. The research has involved numerous tests on large-diameter steel pipe in which fractures were purposely initiated.<sup>4</sup> Correlating the results of full-scale pipe tests with the results of the DWTT indicated that the transition in full-scale fracture propagation appearance (fracture appearance remote from the initiation region) occurred at the same temperature as the transition in the DWTT percent shear area. Thus the DWTT defined a fracture-propagation transition temperature (FPPT).

<sup>4</sup> Brubaker, E. H., and Dennison, J. D., “Use of the Battelle Drop Weight Tear Test for Determining Notch Toughness of Line Pipe Steel,” *Journal of Metals*, Am. Inst. of Mining and Metallurgical Engrs., Vol 17, No. 9, September, 1965, pp. 985-992.

A2.2 ~~The work performed by the Committee E-24 Subcommittee III task group<sup>5</sup> has shown that for specimen thicknesses less than 0.750 in. (19.05 mm) 19.05 mm (0.750 in.) the determination of transition temperature at a specific shear area level is reproducible to  $\pm 10^{\circ}\text{F}$  ( $-12^{\circ}\text{C}$ ); to  $\pm 12^{\circ}\text{C}$  ( $\pm 10^{\circ}\text{F}$ ).~~ Furthermore, the results of the task group have shown that the standard deviations for the determination of percent shear area are as shown in the following table:

---

<sup>5</sup> Supporting data available from ASTM Headquarters. Request RR: #E24-1003.



Shear area, %	Standard Deviation, % SA
0–30	6
31–85	10
86–100	5

*ASTM International takes no position respecting the validity of any patent rights asserted in connection with any item mentioned in this standard. Users of this standard are expressly advised that determination of the validity of any such patent rights, and the risk of infringement of such rights, are entirely their own responsibility.*

*This standard is subject to revision at any time by the responsible technical committee and must be reviewed every five years and if not revised, either reapproved or withdrawn. Your comments are invited either for revision of this standard or for additional standards and should be addressed to ASTM International Headquarters. Your comments will receive careful consideration at a meeting of the responsible technical committee, which you may attend. If you feel that your comments have not received a fair hearing you should make your views known to the ASTM Committee on Standards, at the address shown below.*

*This standard is copyrighted by ASTM International, 100 Barr Harbor Drive, PO Box C700, West Conshohocken, PA 19428-2959, United States. Individual reprints (single or multiple copies) of this standard may be obtained by contacting ASTM at the above address or at 610-832-9585 (phone), 610-832-9555 (fax), or [service@astm.org](mailto:service@astm.org) (e-mail); or through the ASTM website ([www.astm.org](http://www.astm.org)).*