



Standard Practice for Fracture Testing with Surface-Crack Tension Specimens¹

This standard is issued under the fixed designation E 740; the number immediately following the designation indicates the year of original adoption or, in the case of revision, the year of last revision. A number in parentheses indicates the year of last reapproval. A superscript epsilon (ϵ) indicates an editorial change since the last revision or reapproval.

1. Scope

1.1 This practice covers the design, preparation, and testing of surface-crack tension (SCT) specimens. It relates specifically to testing under continuously increasing force and excludes cyclic and sustained loadings. The quantity determined is the residual strength of a specimen having a semielliptical or circular-segment fatigue crack in one surface. This value depends on the crack dimensions and the specimen thickness as well as the characteristics of the material.

1.2 Metallic materials that can be tested are not limited by strength, thickness, or toughness. However, tests of thick specimens of tough materials may require a tension test machine of extremely high capacity. The applicability of this practice to nonmetallic materials has not been determined.

1.3 This practice is limited to specimens having a uniform rectangular cross section in the test section. The test section width and length must be large with respect to the crack length. Crack depth and length should be chosen to suit the ultimate purpose of the test.

1.4 Residual strength may depend strongly upon temperature within a certain range depending upon the characteristics of the material. This practice is suitable for tests at any appropriate temperature.

1.5 Residual strength is believed to be relatively insensitive to loading rate within the range normally used in conventional tension tests. When very low or very high rates of loading are expected in service, the effect of loading rate should be investigated using special procedures that are beyond the scope of this practice.

NOTE 1—Further information on background and need for this type of test is given in the report of ASTM Task Group E24.01.05 on Part-Through-Crack Testing (1).²

1.6 *This standard does not purport to address all of the safety concerns, if any, associated with its use. It is the responsibility of the user of this standard to establish appropriate safety and health practices and determine the applicability of regulatory limitations prior to use.*

¹ This practice is under the jurisdiction of ASTM Committee E08 on Fatigue and Fracture and is the direct responsibility of Subcommittee E08.07 on Linear-Elastic Fracture.

Current edition approved Nov. 1, 2003. Published December 2003. Originally approved in 1988. Last previous edition approved in 1995 as E 740 – 88 (1995) ^{ϵ 1}.

² The boldface numbers in parentheses refer to the list of references at the end of this standard.

2. Referenced Documents

2.1 *ASTM Standards:*³

- E 4 Practices for Force Verification of Testing Machines
- E 8 Test Methods for Tension Testing of Metallic Materials
- E 338 Test Method for Sharp-Notch Tension Testing of High-Strength Sheet Materials
- E 399 Test Method for Plane-Strain Fracture Toughness of Metallic Materials
- E 466 Practice for Conducting Force Controlled Constant Amplitude Axial Fatigue Tests of Metallic Materials
- E 561 Practice for *R*-Curve Determination
- E 1823 Terminology Relating to Fatigue and Fracture

3. Terminology

3.1 *Definitions*—Definitions given in Terminology E 1823 are applicable to this practice.

3.1.1 *crack mouth opening displacement (CMOD), $2v_m$ (L)*—the Mode I (also called opening mode) component of crack displacement due to elastic and plastic deformation, measured at the location on the crack surface that has the greatest elastic displacement per unit load.

NOTE 2—In surface-crack tension (SCT) specimens, CMOD is measured on the specimen surface along the normal bisector of the crack length.

3.1.2 *fracture toughness*—a generic term for measures of resistance to extension of a crack. **E 616**

3.1.3 *original crack size, a_o [L]*—the physical crack size at the start of testing. **(E 616)**

3.2 *Definitions of Terms Specific to This Standard:*

3.2.1 *crack depth, a [L]*—in surface-crack tension (SCT) specimens, the normal distance from the cracked plate surface to the point of maximum penetration of the crack front into the material. Crack depth is a fraction of the specimen thickness.

3.2.1.1 *Discussion*—In this practice, crack depth is the original depth a_o and the subscript *o* is everywhere implied.

3.2.2 *crack length, $2c$ [L]*—in surface-crack tension specimens, a distance measured on the specimen surface between the two points at which the crack front intersects the specimen surface. Crack length is a fraction of specimen width.

³ For referenced ASTM standards, visit the ASTM website, www.astm.org, or contact ASTM Customer Service at service@astm.org. For *Annual Book of ASTM Standards* volume information, refer to the standard's Document Summary page on the ASTM website.

3.2.2.1 *Discussion*—In this practice, crack length is the original length $2c_o$ and the subscript o is everywhere implied.

3.2.3 *residual strength*, σ_r (FL⁻²)—the maximum value of the nominal stress, neglecting the area of the crack, that a cracked specimen is capable of sustaining.

NOTE 3—In surface-crack tension (SCT) specimens, residual strength is the ratio of the maximum load (P_{max}) to the product of test section width (W) times thickness (B), $P_{max}/(BW)$. It represents the stress at fracture normal to and remote from the plane of the crack.

4. Significance and Use

4.1 The surface-crack tension (SCT) test is used to estimate the load-carrying capacity of simple sheet- or plate-like structural components having a type of flaw likely to occur in service. The test is also used for research purposes to investigate failure mechanisms of cracks under service conditions.

4.2 The residual strength of an SCT specimen is a function of the crack depth and length and the specimen thickness as well as the characteristics of the material. This relationship is extremely complex and cannot be completely described or characterized at present.

4.2.1 The results of the SCT test are suitable for direct application to design only when the service conditions exactly parallel the test conditions. Some methods for further analysis are suggested in Appendix X1.

4.3 In order that SCT test data can be comparable and reproducible and can be correlated among laboratories, it is essential that uniform SCT testing practices be established.

4.4 The specimen configuration, preparation, and instrumentation described in this practice are generally suitable for cyclic- or sustained-force testing as well. However, certain constraints are peculiar to each of these tests. These are beyond the scope of this practice but are discussed in Ref. (1).

5. Apparatus

5.1 The procedure involves testing of specimens that have been precracked in fatigue. force versus CMOD, if CMOD is measured, is recorded autographically or digitally.

5.2 *Fatigue Precracking Apparatus*—Axial tension or three-point, four-point, or cantilever bending are all acceptable modes for fatigue precracking. Fixture design is not critical as long as the crack growth is symmetrical and the plane of the crack remains perpendicular to the specimen face and the tensile force vector. The effect of cyclic frequency is thought to be negligible below 100 Hz in a nonaggressive environment.

NOTE 4—Certain crack shapes are more readily produced in axial tension, others in bending (see Annex A1).

5.2.1 Devices and fixtures for cantilever bending of sheet and plate specimens are described in Refs. (2) and (3), respectively. Others may be equally suitable. The axial fatigue machines described in Practice E 466 are suitable for precracking in tension; however, since the precracking operation is terminated prior to specimen failure, one should ensure that load variations during slowdown or shutdown do not exceed those desired.

5.2.2 A magnifier of about 20 power should be used to monitor the fatigue precracking process. Ease of observation will be enhanced if the cyclic rate can be reduced to about 1 Hz

when desired. Alternatively, a stroboscopic light synchronized with the maximum application of tensile force may serve as well.

5.3 *Testing Machine*—The test should be conducted with a tension testing machine that conforms to the requirements of Practices E 4.

5.3.1 The devices for transmitting force to the specimen shall be such that the major axis of the specimen coincides with the load axis. The pin-and-clevis arrangement described in Test Method E 338 should be suitable for specimens whose width is less than about 4 in. (100 mm). An arrangement such as that shown in Fig. 2 of Practice E 561 should be suitable for wider specimens.

5.3.2 For tests at other than room temperature, the temperature control and temperature measurement requirements of Test Method E 338 are appropriate.

5.4 *Displacement Gage (Optional)*—If used to measure CMOD, the displacement gage output should accurately indicate the relative displacement of two gage points on the cracked surface, spanning the crack at the midpoint of its length. Further information on displacement gages appears in Appendix X2.

5.5 For some combinations of material and crack geometry, the crack may propagate entirely through the thickness prior to total failure. Methods of detecting this occurrence, should it be of interest, are discussed briefly in Ref. (1).

6. Test Specimen

6.1 *Configuration and Notation*—The SCT test specimen and the notation used herein are shown in Fig. 1. Grip details have been omitted, since grip design may depend on specimen size (5.3.1) and material toughness. In general, the only

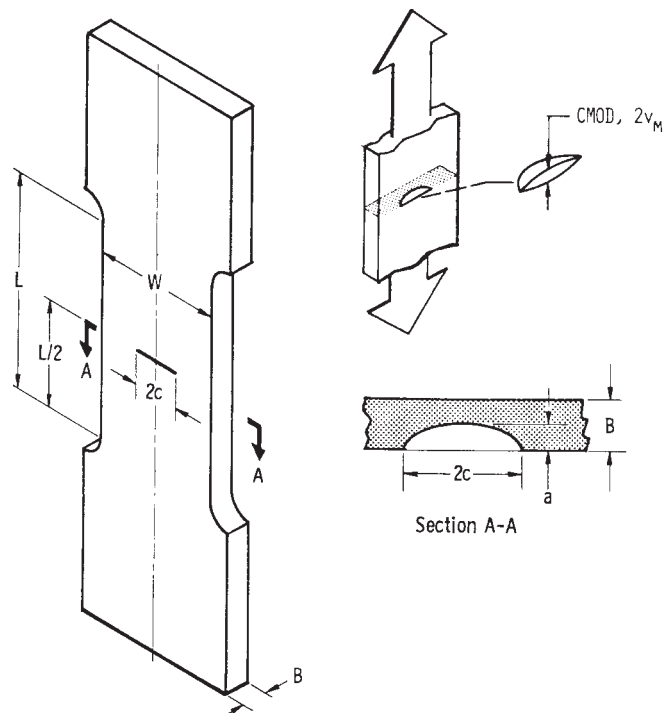

FIG. 1 Typical Surface-Crack Specimen (Grip Details Omitted) and Nomenclature

gripping requirements are that the arrangement be strong enough to carry the maximum expected force and that it allow uniform distribution of force over the specimen cross section.

6.2 *Dimensions*—The crack depth and length and specimen thickness should be chosen according to the ultimate purpose of the test. Further discussion of this subject may be found in Appendix X3. The specimen width W should be at least 5 times the crack length $2c$ and the specimen test section length L should be at least twice the width W . Should these width and length dimensions exceed actual service dimensions, the service dimensions should be used but one should not then attempt to generalize data from such tests.

6.3 *Fatigue Precracking*—The object is to produce at a prescribed location a fatigue crack whose configuration is regular (that is, a half-ellipse or a segment of a circle), whose depth and length are close to predetermined target values, and whose subsequent fracture behavior will not be influenced by any detail of the preparation process. A small slit or crack starter is machined into the specimen surface at the center of the test section (Fig. 2) to locate and help initiate the fatigue crack. Regularity of crack configuration is influenced primarily by fatigue force uniformity, which can be maximized by careful alignment of force train and fixtures. Material inhomogeneity, residual stresses, and starter notch root radius variation can produce irregularities which may be beyond control. Fatigue crack size and shape control are discussed in Annex A1.

6.3.1 Crack starters have been produced by a variety of methods. The following procedures are known to produce acceptable results.

6.3.1.1 The crack starter should be machined, either by slitting with a thin jeweler’s circular saw or similar cutter or by electrical discharge machining (EDM) with a thin, shaped electrode.

6.3.1.2 The crack starter plane should be perpendicular to the specimen face and the tensile force vector within 10° .

6.3.1.3 The starter notch root radius should be less than 0.010 in. (0.25 mm).

6.3.1.4 The crack starter length and depth should be chosen with the desired crack dimensions and the requirements of 6.3.2.2 in mind.

6.3.2 The following procedures should ensure the production of an effective sharp fatigue crack.

6.3.2.1 Fatigue crack with the specimen in the heat treatment condition in which it is to be tested, if at all possible.

6.3.2.2 Whenever it is physically possible, the crack should be extended at least 0.05 in. (1.3 mm); in any event the fatigue crack extension must not be less than 5 % of the final crack depth, and the crack and its starter must lie entirely within an imaginary 30° wedge whose apex is at the crack tip. These two-dimensional descriptions shall apply around the entire crack front, that is, in all planes normal to tangents to all points on the crack periphery (Fig. 2).

6.3.2.3 The ratio of minimum to maximum cyclic stress, R , should not be greater than 0.1.

6.3.2.4 For at least the final 2.5 % of the total crack depth, the ratio K_{\max}/E should not exceed $0.002 \text{ in.}^{1/2}$ ($0.00032 \text{ m}^{1/2}$), where K_{\max} is the maximum stress intensity factor during fatigue cracking and E is the material’s elastic modulus. An estimate of K_{\max} can be computed based on the cyclic stress and the target crack dimensions using the appropriate equation from Annex A2. Compute K_{\max} at the surface or at the deepest point, whichever is greater.

7. Procedure

7.1 *Number of Tests*—If only one crack geometry (that is, fixed crack depth and length) is to be studied, at least three specimens should be tested. If geometry is to be varied, at least two specimens should be tested for each combination of depth-to-length ($a/2c$) and depth-to-thickness (a/B) ratios.

7.2 *Specimen Measurements*—Measure the specimen thickness B at the points midway between each crack tip and the nearest specimen edge, to the nearest 0.001 in. (0.025 mm) or 0.1 %, whichever is larger. If these measurements are not within 3 % of their average, the specimen should be discarded

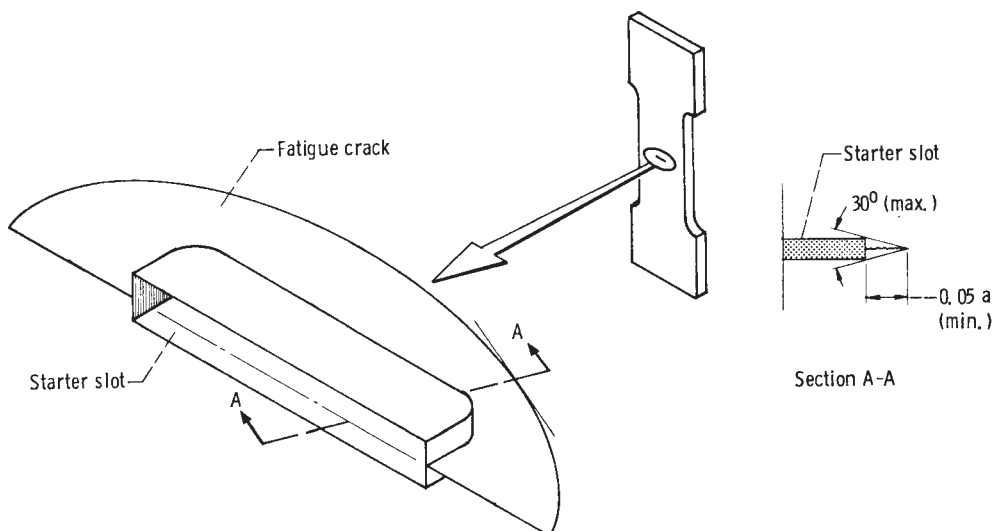

NOTE 1—Section A-A refers to the plane normal to any tangent to the crack periphery and containing the point of tangency.

FIG. 2 Fatigue Crack and Starter Details

or remachined as appropriate. Measure the specimen width W at the crack plane to within 1 % of W .

7.3 *Testing*—Conduct the test in a manner similar to that for an ordinary tension specimen. The test loading rate shall be such that the rate of increase of the nominal stress P/BW is less than 100 000 psi (690 MPa)/min. Record the maximum force, P_{\max} , reached during the test.

7.4 *Test Record*—If CMOD is measured, a test record should be made consisting of an autographic plot or digital record of the output of a force-sensing transducer versus the displacement gage output.

7.5 *Crack Measurements*—After fracture, measure the crack depth a and the crack length $2c$ to the nearest 0.001 in. (0.025 mm) or 0.1 %, whichever is larger. A low-power (20 to 50 ×) traveling microscope is usually satisfactory. Observe the crack shape; it should closely approximate a semiellipse or a segment of a circle. If the crack shape is irregular or unsymmetric the test should be discarded. Using the actual crack dimensions, verify that the requirement 6.3.2.4 was indeed met.

7.6 *Residual Strength*—Calculate the residual strength as $\sigma_r = P_{\max}/(BW)$.

8. Report

8.1 The report should include the following for each specimen tested:

8.1.1 Test section width, W , and thickness, B .

8.1.2 Maximum stress intensity factor during fatigue pre-cracking, K_{\max} , based on actual crack dimensions.

8.1.3 Fatigue crack depth, a , and length, $2c$.

8.1.4 Maximum force observed during the test, P_{\max} , and the corresponding residual strength, σ_r .

8.2 The following should also be reported. If an item is a controlled variable, it should be reported for each specimen; if common to an identifiable block of specimens, it need be reported only once.

8.2.1 Crack starter dimensions.

8.2.2 Mode of loading during fatigue cracking and the stress ratio R .

8.2.3 Test temperature and environment.

8.2.4 Yield strength and tensile strength determined in accordance with Test Methods E 8.

8.2.5 Crack plane orientation (see Test Method E 399).

8.3 If available, the following should also be reported:

8.3.1 Elastic modulus, E , and Poisson's ratio, μ .

8.3.2 Forces corresponding to pop-in or breakthrough.

8.3.3 Dimensionless slope, $2Ev_m/(1-\mu^2)\sigma a$, of the initial linear portion of the force-versus-CMOD curve, and the measurement-point gage length.

8.3.4 Number of fatigue cracking cycles from first visible cracking to final size.

9. Keywords

9.1 residual strength; surface crack; tensile force

ANNEXES

(Mandatory Information)

A1. FATIGUE CRACK SIZE AND SHAPE CONTROL

A1.1 Fatigue crack size and shape control is more of an art than a science at present. There appear to be two basic techniques.

A1.2 One approach is to vary the starter size and shape or the stress field or both to achieve the desired final configuration. In axial tension, cracks grown from simulated point defects tend to remain nearly semicircular as they grow; in bending, cracks become more highly elliptical as they grow. These propagation paths are approximately

$$a/c = 1 - 0.2(a/B)^2 \quad \text{in tension, or}$$

$$a/c = 1 - (a/B) \quad \text{in bending}$$

for $a/B \leq 0.7$. Cracks or starters on these paths will tend to remain on them, and those not on them will tend to approach them with further cycling. The propagation path for a given starter configuration can be determined experimentally by alternately fatigue cycling and marking (low stress cycling). Then the specimen is broken and points on the propagation

path are obtained by measuring the marking bands on the fracture face. When propagation paths have been determined for several starter configurations, the starter size that should give the desired final size and shape can be selected and the crack depth inferred fairly closely from measurements of the crack length. Further information on this approach can be found in Refs. (3) and (4).

A1.3 The other approach is to use a very sharp starter of very nearly the desired final dimensions. If the fatigue crack is then grown only a short distance, the crack shape will not change very much. Although this approach would seem to be simpler, its proper use requires some experience. The starter slit must be wide enough at the surface to allow observation of the root but should not violate the requirements of 6.3.2.2. Fatigue cracking is terminated when the fatigue crack is visible around the entire starter periphery. The resulting fatigue crack will usually meet the requirements of 6.3.2.2.

A2. STRESS INTENSITY FACTOR EQUATIONS

A2.1 As yet there is no exact solution for the problem of a semielliptical surface crack in a plate of finite dimensions. The following equations, taken from Ref. (5), were obtained by fitting to finite element calculations. They are considered to be sufficiently accurate for the purposes of this practice and are limited to cases where $a \leq c$ and $a \leq 0.8 B$.

A2.2 Under uniform tensile stress σ_t , at the deepest point on the crack periphery

$$K/\sigma_t \sqrt{\pi a} = M/\Phi \quad (\text{A2.1})$$

and near the surface

$$K/\sigma_t \sqrt{\pi a} = (M/\Phi)S \quad (\text{A2.2})$$

where:

$$M = \{ 1.13 - 0.09(a/c) \} \\ + \{ -0.54 + 0.89 \cdot [0.2 + (a/c)]^{-1} \} (a/B)^2 \\ + \{ 0.5 - [0.65 + (a/c)]^{-1} \} \\ + 14 (1 - a/c)^{24} \} (a/B)^4$$

$$\Phi^2 = 1 + 1.464 (a/c)^{1.65} \\ S = \sqrt{a/c}$$

A2.3 Under bending with nominal outer-fiber stress σ_b , at the deepest point on the crack periphery

$$K/\sigma_b \sqrt{\pi a} = (M/\Phi)H_2 \quad (\text{A2.3})$$

and near the surface

$$K/\sigma_b \sqrt{\pi a} = (M/\Phi)SH_1 \quad (\text{A2.4})$$

where:

$$H_2 = 1 - [1.22 + 0.12 (a/c)] (a/B) + \\ + [0.55 - 1.05 (a/c)^{0.75} + 0.47 (a/c)^{1.5}] (a/B)^2 \\ H_1 = 1 - [0.34 + 0.11 (a/c)] (a/B)$$

A2.4 The curves in Fig. A2.1 show the values of a/B and a/c for which (Eq A2.1) equals (Eq A2.2) and for which (Eq A2.3) equals (Eq A2.4). Above the appropriate line, K is greater at the surface; below it, K is greater at the deepest point.

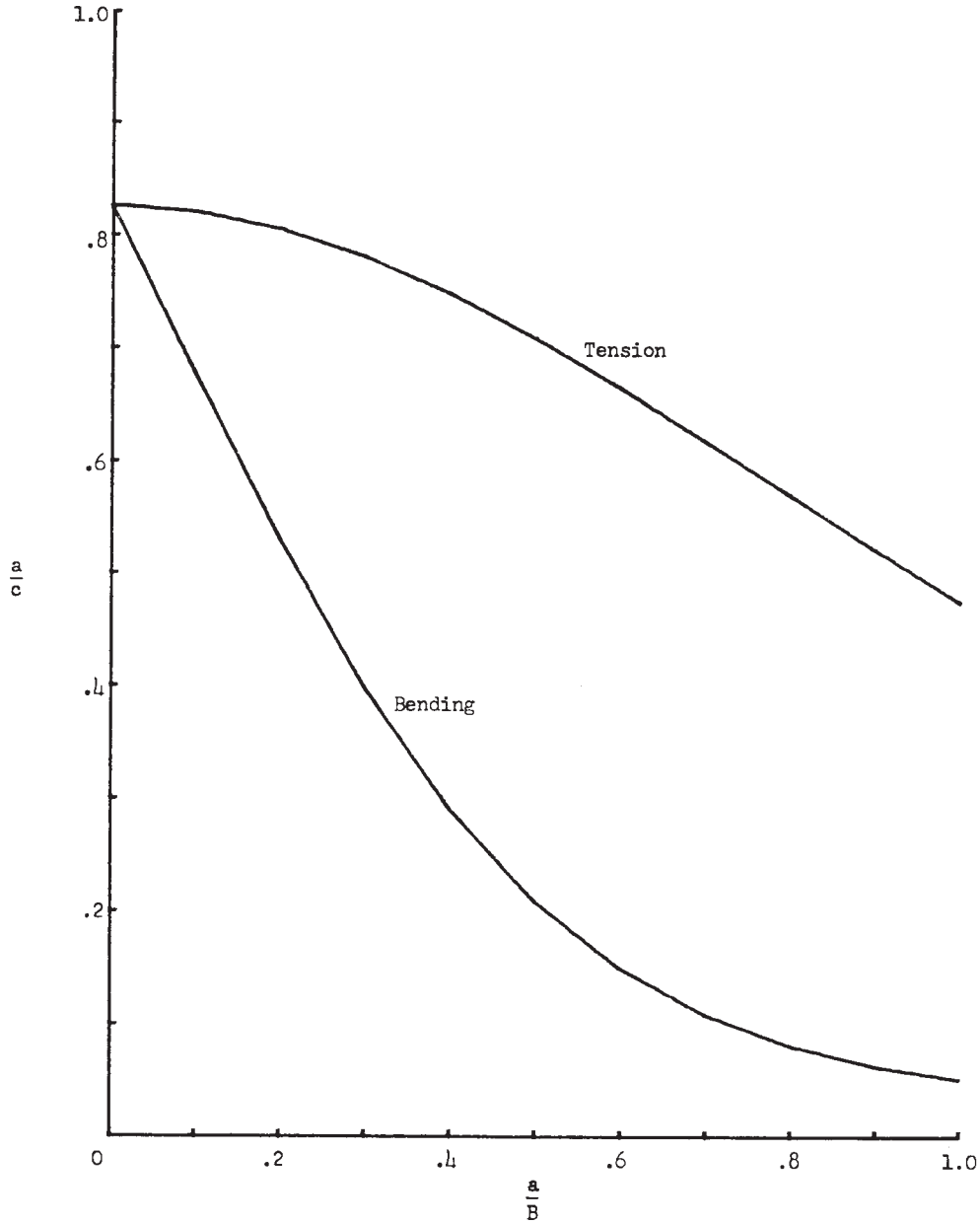

FIG. A2.1 Values of a/c and a/B for Which K is Equal at the Surface and at the Deepest Point on the Crack Periphery

APPENDIXES

(Nonmandatory Information)

X1. METHODS FOR FURTHER ANALYSIS

X1.1 A number of different types of fracture specimens have been developed to date. Of these, the SCT specimen is one of the most representative of structures with defects that actually occur in service. However, it is probably the most difficult of all to interpret and generalize. There are essentially three methods available for further analysis of residual strength data from SCT tests. These are the linear elastic fracture mechanics (LEFM) method, the semiempirical method, and the

empirical method. The choice of method may depend on the results of testing and is not always the free choice of the investigator.

X1.2 *The LEFM Method* is based on the assumption that failure occurs when the maximum stress intensity factor (SIF) around the periphery of a surface crack exceeds a critical value. It has long been common practice to compute a nominal

fracture toughness value based on original crack dimensions and maximum force for use as an aid in interpreting SCT test results. However, this method is useful only under limited conditions. Outside these limitations, empirical or semiempirical methods should be used.

X1.2.1 The SCT specimen fracture toughness, K_{Ie} ($FL^{-3/2}$), is a nominal fracture toughness value based on residual strength and original crack dimensions. It is computed as

$$K_{Ie} = (\sigma_r \sqrt{\pi a}) (M/\phi) \quad (X1.1)$$

where M and ϕ are given in Annex A2.

Discussion—This value was designated K_{IE} in Ref. (1), but that designation is not consistent with Terminology E 1823.

X1.2.2 For low-toughness materials, where crack-tip plastic zones are small and stable crack growth prior to failure is generally absent, a characterization based on original crack dimensions and maximum force is appropriate and has proven useful. For tough materials, however, such a characterization may be questionable. If the original crack dimensions are not large with respect to the plastic zone size, the basic assumptions of LEFM are violated; also, general yielding may occur prior to failure. If the uncracked ligament depth (thickness minus crack depth, $B - a$) is small, the ligament may yield prior to failure, the original crack dimensions are no longer pertinent and the likelihood of ligament yielding is increased. Limited experiments indicate that the SCT fracture toughness K_{Ie} will be reasonably constant provided that stable subcritical crack growth is not significant and that both the crack depth a and the ligament depth $B - a$ are greater than $0.5 (K_{Ie}/\sigma_{ys})^2$, where σ_{ys} is the material yield strength. Otherwise, K_{Ie} may vary significantly with crack size and shape as well as with specimen thickness.

X1.2.3 Stable subcritical growth of surface cracks under rising force may occur with no visible evidence left on the fracture face, and was generally ignored in the past. Recent advances in CMOD measurement techniques now allow at least a qualitative evaluation of stable crack growth (see

Appendix X2). Quantitative evaluation requires analytical techniques which are beyond the scope of this document.

X1.2.4 It may be helpful to estimate in advance whether the LEFM method might be usable in a particular series of tests. This may be done as follows. For the material in question, compute the ratio σ_{ys}/E . From the table in 7.1.3 of Test Method E 399, obtain the corresponding minimum recommended thickness and crack length for a K_{Ic} test, and multiply that dimension by 0.2. The resulting value is a very rough estimate of $0.5 (K_{Ie}/\sigma_{ys})^2$. If both the crack depth and the uncracked ligament depth are greater than this value, the data will probably be analyzable by the LEFM method. If not, an empirical or semiempirical approach should be anticipated. This calculation does not guarantee that a meaningful K_{Ie} value will be obtained from a single test. That can only be determined by examining the results of tests covering a range of the geometric variables a/c and a/B .

X1.2.5 The fact that K_{Ie} values which are constant within a given degree are obtained over a range of the geometric variables a/c and a/B does not guarantee that the same degree of constancy will hold outside that range.

X1.3 *Semiempirical Methods*—A number of semiempirical methods are mentioned in Ref. (1). Of these, the method of Ref. (7) appears to be the most generally useful. The only limitations claimed for this method are that the net-section stress at failure, $P_{max}/(BW - \pi ac/2)$, be less than the yield strength and that the geometrical parameters a/c and a/B be within the limits of the appropriate SIF equation. Since two empirical parameters must be determined, at least two crack geometries must be tested.

X1.4 *Empirical Method*—Residual strength is plotted against some measure of crack size. In most cases the parameter a/Φ^2 is as good a measure of crack size as any, but in other cases the parameter a/B may be more appropriate. For very ductile materials, it is sometimes helpful to plot net-section failure stress (X3.3) against aF^2 , where F is the right-hand side of (Eq A2.1) or (Eq A2.2), whichever is greater. Conventional mathematical procedures may be used for interpolation, but extrapolation should be avoided.

X2. CRACK MOUTH OPENING DISPLACEMENT

X2.1 Experimenters have learned that valuable information can be obtained from crack mouth opening displacement (CMOD) measurements on SCT specimens. The secant modulus corresponding to any point on a force-CMOD curve is in principle relatable to the effective crack size at that force. Interpretation of CMOD measurements is discussed in more detail in Ref. (1).

X2.2 Current experimental techniques used for CMOD measurements on SCT specimens are similar to those used in Test Method E 399, but differ in that, except for very large SCT

specimens, knife edges cannot be machined into the mouth of a surface crack. Instead, small brackets with integral knife edges, as shown in Fig. X2.1, are micro spotwelded to the specimen as near as possible to the crack. Displacement gages similar or identical to the Test Method E 399 gage should be adequate.

X2.3 Alternative measurement techniques may be equally successful. An example of an alternative gage configuration and attachment method is contained in Ref. (6). Optical displacement methods may also prove successful.

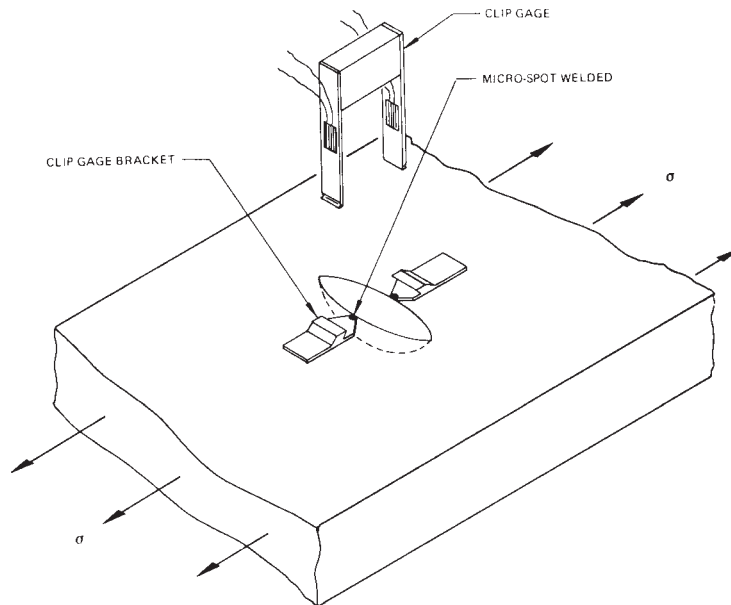

FIG. X2.1 Typical Experimental Setup for CMOD Measurement

X3. TEST PLAN

X3.1 It is reasonable to choose the surface crack configuration most closely resembling the type of flaw likely to occur in service. For example, a lack of penetration in a one-pass weldment might best be modeled by a long shallow surface crack, or an etch pit by a semicircular surface crack. The range of crack size and shape that must be covered will depend on the ultimate purpose of the test. A crack size range that results in a residual strength range from near ultimate tensile strength to about 80 % of design operating stress will generally be adequate for design purposes.

X3.2 In some situations the testing of a single crack geometry may be sufficient and the residual strength may be an adequate characterization. For example, the object of the test may be to determine the residual strength of a plate-like structural element containing the largest semicircular crack that

might be missed by nondestructive inspection. In such a case the test plan is quite simple and straightforward.

X3.3 In other cases the effects of crack size or shape or both are of interest. In such cases there can be no advance assurance that meaningful information can be derived from the results of any single SCT test. The range of crack geometry that should be covered will depend on the ultimate application, and the number of geometries to be tested will depend on the degree of confidence required.

X3.4 When both the crack depth ratio (a/B) and the crack shape (a/c) are to be varied, the test plan should include at least three significantly different values of the variable considered more important to the application and at least two values of the less important variable.

REFERENCES

- (1) Orange, T. W., "Fracture Testing with Surface Crack Specimens," *Journal of Testing and Evaluation*, Vol 3, No. 5, September 1975, pp. 335-342.
- (2) Yen, C. S., and Pendleberry, S. L., "Techniques for Making Shallow Cracks in Sheet Metals," *Materials Research & Standards*, November 1962, pp. 913-916.
- (3) Pierce, W. S., and Shannon, J. L., Jr., "Surface-Crack Shape Change in Bending Fatigue Using an Inexpensive Resonant Fatiguing Apparatus," *Journal of Testing and Evaluation*, Vol 6, No. 3, May 1978, pp. 183-188.
- (4) Corn, D. L., "A Study of Cracking Techniques for Obtaining Partial Thickness Cracks of Pre-Selected Depths and Shapes," *Engineering Fracture Mechanics*, Vol 3, No. 1, July 1971, pp. 45-52.
- (5) Newman, J. C., Jr., and Raju, I. S., "Analyses of Surface Cracks in Finite Plates Under Tension or Bending Loads," NASA TP-1578, 1979.
- (6) Schwartzberg, F. R., King, R. G., and Todd, P. H., Jr., "Definition of Mutually Optimum NDI and Proof Test Criteria for 2219 Aluminum Pressure Vessels. Volume II: Optimization and Fracture Studies," Martin-Marietta Corp., NASA CR-135446, 1979.
- (7) Newman, J. C., Jr., "Fracture Analysis of Surface- and Through-Cracked Sheets and Plates," *Engineering Fracture Mechanics*, Vol 5, 1973, pp. 667-689.

ASTM International takes no position respecting the validity of any patent rights asserted in connection with any item mentioned in this standard. Users of this standard are expressly advised that determination of the validity of any such patent rights, and the risk of infringement of such rights, are entirely their own responsibility.

This standard is subject to revision at any time by the responsible technical committee and must be reviewed every five years and if not revised, either reapproved or withdrawn. Your comments are invited either for revision of this standard or for additional standards and should be addressed to ASTM International Headquarters. Your comments will receive careful consideration at a meeting of the responsible technical committee, which you may attend. If you feel that your comments have not received a fair hearing you should make your views known to the ASTM Committee on Standards, at the address shown below.

This standard is copyrighted by ASTM International, 100 Barr Harbor Drive, PO Box C700, West Conshohocken, PA 19428-2959, United States. Individual reprints (single or multiple copies) of this standard may be obtained by contacting ASTM at the above address or at 610-832-9585 (phone), 610-832-9555 (fax), or service@astm.org (e-mail); or through the ASTM website (www.astm.org).