



Designation: E 83 – 00^{ε1}₂

An American National Standard

Standard Practice for Verification and Classification of Extensometer System¹

This standard is issued under the fixed designation E 83; the number immediately following the designation indicates the year of original adoption or, in the case of revision, the year of last revision. A number in parentheses indicates the year of last reapproval. A superscript epsilon (ϵ) indicates an editorial change since the last revision or reapproval.

This standard has been approved for use by agencies of the Department of Defense.

^{ε1} NOTE—The Word “System” was added editorially to the title in November 2001.

1. Scope

1.1 This practice covers procedures for the verification and classification of extensometer systems, but it is not intended to be a complete purchase specification. The practice is applicable only to instruments that indicate or record values that are proportional to changes in length corresponding to either tensile or compressive strain. Extensometer systems are classified on the basis of the magnitude of their errors.

1.2 Because strain is a dimensionless quantity, this document can be used for extensometers based on either SI or US customary units of displacement.

NOTE 1—Bonded resistance strain gages directly bonded to a specimen cannot be calibrated or verified with the apparatus described in this practice for the verification of extensometers having definite gage points. (See procedures as described in Test Methods E 251.)

1.3 *This standard does not purport to address all of the safety concerns, if any, associated with its use. It is the responsibility of the user of this standard to establish appropriate safety and health practices and determine the applicability of regulatory limitations prior to use.*

2. Referenced Documents

2.1 *ASTM Standards:*

¹ This practice is under the jurisdiction of ASTM Committee E28 on Mechanical Testing and is the direct responsibility of Subcommittee E28.01 on Calibration of Mechanical Testing Machines and Apparatus.

Current edition approved Dec. 10, 2000². Published February 2001; August 2002. Originally published as E 83 – 50. Last previous edition E 83 – 9800^{ε1}.

- E 6 Terminology Relating to Methods of Mechanical Testing²
 E 21 Test Methods for Elevated Temperature Tension Tests of Metallic Materials²
 E 251 Test Methods for Performance Characteristics of Metallic Bonded Resistance Strain Gages²

3. Terminology

- 3.1 *Definitions:* In addition to the terms listed, see Terminology E 6.
- 3.1.1 *calibration*—a determination of the calibration factor for a system using established procedures.
- 3.1.2 *calibration factor*—the factor by which the change in extensometer reading must be multiplied to obtain the equivalent strain.
- 3.1.2.1 *Discussion*—For any extensometer, the calibration factor is equal to the ratio of change in length to the product of the gage length and the change in the extensometer reading. For direct-reading extensometers the calibration factor is unity.
- 3.1.3 *compressometer*—a specialized extensometer used for sensing negative or compressive strain.
- 3.1.4 *deflectometer*—a specialized extensometer used for sensing of extension or motion, usually without reference to a specific gage length.
- 3.1.5 *error, in extensometer systems*—the value obtained by subtracting the correct value of the strain from the indicated value given by the extensometer system.
- 3.1.6 *extensometer, n*—a device for sensing strain. ~~An extensometer may be one of two types:~~
- 3.1.7 ~~Self-contained type.~~
- 3.1.8 ~~Non-self-contained type (that requires an auxiliary device (for example, recorder, digital readout, computer display, etc.)) for readout of strain values.~~
- 3.1.8.1 *Discussion*—For some extensometers the gage length is fixed, while for others the gage length is variable and must be set or determined before the linear strain can be calculated.
- 3.1.9 ~~extensometer strain.~~
- 3.1.7 *extensometer systems*—a system for sensing and indicating strain.
- 3.1.7.1 *Discussion*—The system will normally include an extensometer, conditioning electronics and auxiliary device (recorder, digital readout, computer, etc.). However, completely self-contained mechanical devices are permitted. An extensometer system may be one of three types.
- 3.1.8 *Type 1 extensometer system, n*—an extensometer system which both defines gage length and senses extension, for example, a clip-on strain gage type with conditioning electronics.
- 3.1.9 *Type 2 extensometer system, n*—an extensometer which senses extension and the gage length is defined by specimen geometry or specimen features such as ridges or notches.
- 3.1.9.1 *Discussion*—~~The system may be an—~~A Type 2 extensometer of is used where the self-contained type or the combination of an extensometer of gage length is determined by features on the non-self-contained transducer type specimen, for example, ridges, notches, or overall height (in case of compression test piece). The precision associated with gage length setting for a Type 2 extensometer should be specified in relevant test method or product standard. The position readout device, on a testing machine is not recommended for use in a Type 2 extensometer system.
- 3.1.10 ~~resolution of the strain indicator~~Type 3 extensometer system, n—the smallest change in—an extensometer system which intrinsically senses strain that can be estimated or ascertained on the strain indicating apparatus of the testing system, at any applied strain. (ratiometric principle), for example, video camera system.
- 3.1.11 ~~resolution of analog type indicator (dials, recorders, and so forth)~~gage length (L), n—the strain represented by one graduation multiplied by the ratio original length of the width that portion of the pointer specimen over which strain or pen line to change of length is determined.
- 3.1.11.1 *Discussion*—~~If the center distance between two adjacent graduation marks. The typical ratios device is used are 1:1, 1:2, 1:5, for sensing extension or 1:10. A spacing of 0.10 in. (2.5 mm) or greater motion, and gage length is recommended for a resolution equal to predetermined by the specimen geometry or specific test method, then only resolution and strain represented by 1:10 of error for a graduation. A ratio less than 1:10 specified gage length should not be used. determine the class of extensometer system.~~
- 3.1.12 *resolution of the strain indicator*—the smallest change in strain that can be estimated or ascertained on the strain indicating apparatus of the testing system, at any applied strain.
- 3.1.13 *resolution of the digital type strain indicators (numeric displays, printouts, and so forth)*—the resolution is the smallest change in strain that can be displayed on the strain indicator (may be a single digit or a combination of digits) at any applied strain.
- 3.1.13.1 *Discussion*—If the strain indication, for either type of strain indicator, fluctuates more than twice the resolution, as described in 3.1.11 or 3.1.12, the resolution expressed as a strain shall be equal to one-half the range of fluctuation.
- 3.1.13.4 *verification*—a determination that a system meets the requirements of a given classification after calibration according to established procedures.
- 3.1.14.5 *verification apparatus*—a device for verifying extensometer systems.

² Annual Book of ASTM Standards, Vol 03.01.

3.1.145.1 *Discussion*—This device is used to simulate the change in length experienced by a test specimen as a result of the applied force. The extensometer may either be attached directly to the mechanism or interfaced with it in a manner similar to normal operation (that is, possibly without contact for some optical extensometers).

4. Verification Apparatus

4.1 The apparatus for verifying extensometer systems shall provide a means for applying controlled displacements to a simulated specimen and for measuring these displacements accurately. It may consist of a rigid frame, suitable coaxial spindles, or other fixtures to accommodate the extensometer being verified, a mechanism for moving one spindle or fixture axially with respect to the other, and a means for measuring accurately the change in length so produced,³ or any other device or mechanism that will accomplish the purpose equally well. The mechanism provided for moving one spindle relative to the other shall permit sensitive adjustments. The changes in length shall be measured, for example, by means of an interferometer, calibrated standard gage blocks and an indicator, a calibrated micrometer screw, or a calibrated laser measurement system. If standard gage blocks and an indicator, or a micrometer screw, are used, they shall be calibrated and their limits of accuracy and sensitivity stated. The errors of the verification apparatus shall not exceed one third of the permissible error of the extensometer.

4.2 The verification apparatus shall be calibrated at intervals not to exceed two years.

NOTE 2—He-Ne laser interferometer measurement systems based on the 0.633 μm wavelength line are considered to be primary-based displacement standards and do not require recalibration.⁴

4.3 If the verification apparatus is to be used to verify extensometers used for bidirectional tests, the errors of the verification apparatus should be measured in both directions of travel so as to include any backlash present.

5. Verification Procedure for Extensometer Systems

5.1 *General Requirements*—The verification of an extensometer system should not be done unless the components of the system are in good working condition. Thoroughly inspect all parts associated with smooth operation of the instrument to ensure there are no excessively worn components. Repair or replace parts as necessary. Remove any dirt particles which may have accumulated through normal use of the instrument. Verification of the system shall be performed whenever parts are interchanged or replaced.

5.1.1 The verification of an extensometer system refers to a specific extensometer used with a specific readout device. Unless it can be demonstrated that autographic extensometers and recorders of a given type may be used interchangeably without introducing errors that would affect the classification of the extensometer, the extensometer shall be calibrated with the readout device with which it is to be used.

5.1.2 Prior to the initial verification, the extensometer should be calibrated according to the manufacturer's instructions or established procedures. The calibration procedure may include adjustment of span or determination of calibration factor, or both.

5.2 *Gage Length Measurement Method*— Measure the gage length of self-setting instruments by either the direct or indirect method.

NOTE 3—The following is an example of an indirect method. Set the extensometer to its starting position and mount it on a soft rod of the typical specimen size or diameter. After the extensometer is removed, measure the distance between the marks left by the gage points (or knife edges). If there are four or more gage points, take the average of the individual lengths as the gage length. The differences between individual measurements shall not exceed the tolerance given for the class of extensometer. If there are two gage points (or knife edges), but on opposite sides of the specimen, attach the extensometer twice rotating it 180° with respect to the rod. Take the average of the lengths thus established on each side of the rod as the gage length.

5.2.1 Make two measurements of the gage length. Determine and record the error from each measurement, which is the difference between the measured gage length and the specified gage length, expressed as a percent of the specified gage length.

5.2.2 For extensometer devices that do not have a self-setting gage length during use, such as deflectometers and some high-temperature tensile or creep extensometers, verification run errors should be calculated using the gage length for which the device is used. Separate classifications should be established for each gage length or range used.

5.2.3 Some extensometers have the capability to measure the gage length set by or chosen by the user. If this measurement is used in the calculation of strain, then it is the inherent measurement accuracy that is the important factor rather than the error between the chosen length and the actual.

NOTE 4—An example of an extensometer that is described by 5.2.3 is an optical extensometer that measures the position of “flags” attached to the test specimen. The flags are positioned at the approximate required gage length and the instrument measures the position of the flags (the actual gage length) before and after the specimen is stressed. Although this kind of device usually has a stated accuracy of gage length, it must be verified by either direct or indirect methods at the appropriate gage lengths.

5.3 *Position of Extensometer*—Carefully position the extensometer on or interface it to the verification device in the same manner as it is normally used for typical specimens. For extensometers that attach directly to the specimen, the verification device should allow attachment to pieces that are similar to the specimen on which the extensometer will be attached.

³ A review of some past, current, and possible future methods for calibrating strain measuring devices is given in the paper by Watson, R. B., “Calibration Techniques for Extensometry: Possible Standards of Strain Measurement,” *Journal of Testing and Evaluation*, JTEVA, Vol. 21, No. 6, November 1993, pp. 515–521.

⁴ A letter from NIST (National Institute of Standards and Technology) is available for reference. Request RR:E 28-1013 from ASTM Headquarters.

5.4 *Temperature Control*—Verify the extensometer at approximately the same temperature at which it will be used. Allow sufficient time for the verification device and extensometer to reach satisfactory temperature stability. Maintain temperature stability by excluding drafts throughout the subsequent verification. Record the temperature during each verification run.

NOTE 5—Extensometers used for high-temperature testing may be verified at ambient temperature to insure proper operation, but fixtures should be designed to verify performance at the actual test temperature. This is especially true with optical extensometers which may be adversely affected by air density changes associated with thermal gradients and turbulence, environmental chamber windows, or specimen changes due to the environment. See Appendix X2.

5.5 *Method of Reading*—Read the instrument or, in the case of an autographic extensometer, measure the record in the same manner as during use.

5.5.1 For extensometer with dial micrometers or digital readouts, the readings shall be recorded. Extensometers that use autographic methods shall have their charts read and recorded using a suitable measuring device, such as a vernier or dial caliper. The use of an optical magnifying device is recommended when reading and measuring autographic records.

NOTE 6—When autographic extensometer systems are used, care should be taken to minimize errors introduced by variances in the graph paper. These errors can be due to dimensional changes from reproduction or humidity changes. Direct measurement of the trace soon after it was made eliminates the graph paper errors and is desirable for systems verification.

NOTE 7—If an extensometer is equipped with a dial micrometer, it may be necessary to lightly tap the dial micrometer to minimize the effects of friction and to ensure that the most stable and reproducible readings are obtained. If the dial micrometer is tapped during the verification procedure, include this information in the report.

5.6 *Zero Adjustment*—After temperature stability has been achieved, displace the verification device (with extensometer in the test position) to a slightly negative value and return to zero. If the reading does not return to zero, adjust and repeat the procedure until the reading does return to zero.

5.7 *Number of Readings*—For any strain range, verify the extensometer system by applying at least five displacement values, not including zero, at least two times, with the difference between any two successive displacement applications being no greater than one-third the difference between the selected maximum and minimum displacements.

5.7.1 Extensometers need not be verified beyond the range over which they will be used. Multi-range (multi-magnification) extensometers shall be verified for each range to be used.

NOTE 8—If the connection between the gage points attached to the specimen and the indicating device is made through geared wheels or micrometer screws, relatively large periodic errors may exist which might not be disclosed by this overall procedure. For such extensometers it may be necessary to take additional readings within one turn of any geared wheel, micrometer screw, or the travel of one tooth of any meshing gear.

5.7.2 When it is desired to establish the range of an extensometer system designed to automatically select or extend ranges below 10 % of full scale without the influence of the operator, the number of readings shall depend on how many overlapping decades are in the range. Extensometer readings should be chosen starting with the minimum reading and are grouped in overlapping decades such that the maximum reading on one decade is the minimum on the next decade. There are to be at least five strain applications per decade, unless the maximum, or the minimum strain on the range is reached before completing the decade. Strain (displacements) in each decade are to be approximately 1:1, 2:1, 4:1, 7:1, and 10:1, starting with the minimum strain in each decade.

5.7.2.1 In no case should the distance between two successive strains (displacements) within a decade differ by more than one-third the difference between the minimum and maximum strains in that decade. Strains in the second successive run are to be approximately the same as those of the first run. Report all percent values of accuracy, and report the indicator resolution at least once per decade.

5.7.3 *Lower Limit Criteria*—as indicated in Table 1, all verified strain readings must have a resolution at least one-half the allowable error, that is, the resolution is a limiting factor to determine a lower limit of the range. The lowest verified strain reading must be at least 100 times the indicator resolution. Extensometer results used below the lowest verified strain reading may not comply with the error limit specified by this standard practice.

TABLE 1 Classification of Extensometer Systems

Classification ^A	Relative Error of Gage Length (max %) (See 5.2)	Resolution not to Exceed the Greater of:		Error of Strain ^B not to Exceed the Greater of:	
		Fixed Value (in./in. m/m)	% of Reading	Fixed Error (in./in. m/m)	Relative Error (% of strain)
Class A	±0.1	0.00001	0.05	±0.00002	±0.1
Class B-1	±0.25	0.00005	0.25	±0.0001	±0.5
Class B-2	±0.5	0.0001	0.25	±0.0002	±0.5
Class C	±1	0.0005	0.5	±0.001	±1
Class D	±1	0.005	0.5	±0.01	±1
Class E	±1	0.05	0.5	±0.1	±1

^A Class A classification is very difficult to achieve at short (1 in. (25 mm) or less) gage lengths, so the commercial availability of an extensometer system that meets this requirement may be very limited or nonexistent.

^B The strain of an Extensometer System is the ratio of applied extension to the gage length.

NOTE 9—*Example:* For an extensometer with a gage length of 1 in. and 50 % strain, the full scale displacement value is 0.5 in. If the machine (system) resolution is 0.00005 in., which meets the criteria for the B1 class, the lower limit (verification range) would be 0.00005 in. x 100 = 0.005 in., or 0.5 % strain. The suitable verification points for a single range extensometer system would be in percent strain 0.5, 1.0, 2.0, 3.5, 5, 10, 20, 35, and 50. (See Fig. X1.2 for single range system and Fig. X1.4 for multirange.)

5.8 *Number of Runs*—Take at least two complete sets of extensometer readings for the same changes of length. After the first run, an operation that simulates normal operation should be used to check repeatability. An extensometer that attaches directly to the specimen should be removed and then reattached to the verification device between runs. An extensometer that does not attach directly to the specimen should be moved away from the verification device (or the device moved away from the extensometer) to simulate the changing of test specimens.

5.8.1 If the initial verification run (the “as found” run) produces satisfactory results which classify an extensometer system according to Table 1 specifications, then the data may be used as run—one of the two required for the verification report.

5.8.2 If the initial verification run produces results which are outside of expectations, for example, Class C instead of B1, and adjustments are necessary, then this first verification run might be reported “as found” data and used in accordance with applicable quality control programs. Calibration adjustments may then be made to the extensometer system after which two required verification runs shall be conducted and reported on the verification report and certificate.

5.9 *Direction of Verification Displacement :*

5.9.1 *Extensometers Used for Unidirectional Tests*—Ex-tensometers used for unidirectional tests (for example, tension tests) shall be verified by applying displacement in the direction of testing normally used. If start-up backlash is evident, the verification device (with extensometer in place) may be displaced to a slightly negative value and returned to zero before each run.

NOTE 10—This verification procedure does not measure the initial backlash in the extensometer that may appear after it is first attached to the specimen. If the extensometer is used with open or closed loop-type test equipment in load control, the users should disregard readings taken during the initial part of the loading curve. If the extensometer is used with closed loop test equipment in strain control, the backlash could result in large tension or compression loads during the initial part of the loading curve.

5.9.2 *Extensometers Used for Bidirectional Tests*—Extensometers used for bidirectional tests (for example, hysteresis tests, fatigue tests, and so forth) (See Appendix X3) shall be verified by applying both increasing and decreasing values of displacement over the total range of intended use. Displace the verification device (with extensometer in place) to a slightly negative value and return to zero before each run. During each run, displace the extensometer to the maximum positive value, then to the maximum negative value, and then back to zero, stopping at each verification point along the way in each direction.

5.10 *Determination of Errors*—Calculate the error of the extensometer system for each change in length of the verification apparatus. Errors are based on net values from the zero point to each successive verification point, not on increments between verification points.

6. Classification of Extensometer Systems

6.1 Classify extensometer systems in accordance with the requirements as to maximum error of strain indicated by the extensometer system shown in Table 1. The maximum allowable error in each class is the fixed error or the variable error, whichever is greater. The fixed error will establish the maximum allowable error for readings near zero, but the variable error may establish the maximum allowable error for readings near full scale. Two examples of this procedure are presented in Appendix X1. In addition, the gage length error for self-setting Type 1 extensometers shall not exceed the greater of the values shown in Table 1.

6.1.1 Type 2 extensometer systems shall be classified using the smallest gage length for which they are used. They may be verified at additional gage lengths if desired.

6.1.2 Type 3 extensometer systems, operating over a range of gage lengths, shall be verified at the minimum and maximum gage lengths used. They may be verified at additional gage lengths if desired.

NOTE 11—For Type 3 systems, precision marked, divided test pieces may be used to establish known gage lengths on the calibration device. Known extensions enable the applied strains to be set. These applied strains are compared with the indicated strains from the Type 3 extensometer systems, in order to establish its classification in accordance with the requirements for resolution and strain error in Table 1.

6.2 Separate classifications may be established for different ranges of multi-range (multiple-magnification) extensometer systems.

7. Verification of Multiple Strain Readouts

7.1 When an extensometer is to be used with two or more readout devices (for example, a graphic recorder and a digital readout), steps must be taken to assure that errors are not introduced by interactions (mechanical or electrical) between the readout devices or between the readouts and the extensometer, and that values from each readout device satisfy appropriate performance criteria. (Different accuracy classifications could be given to the systems using different readout devices.) This can best be accomplished by verifying each system (extensometer and readout device) individually and also in combinations that would be used simultaneously. As an alternative, after individual verifications have been made, the combination can be checked at three points (about 20, 50, and 90 % of full scale range are recommended); and, if values for each system do not differ from the individual verification values by more than 20 % of the class tolerance, the combined system shall be considered to meet the same

requirements as the individual systems. If readout devices are always used in combination, individual verifications are not required when the combined system is verified as a unit.

8. Verification of Data Acquisition Systems

8.1 Extensometer systems in which strain values are indicated on displays or printouts of data acquisition systems, be they instantaneous, delayed, stored or retransmitted, which are verified in accordance with the provisions of Section 5 and classified in accordance with the provisions of Section 6, shall be deemed to comply with this practice.

9. Time Interval Between Verifications

9.1 It is recommended that extensometer systems be verified annually unless more frequent verification is required to comply with product or customer specifications. In no case shall the time interval between verifications exceed 18 months unless an extensometer is being used on a long-time test running beyond the 18-month period. In such cases, the extensometer system shall be verified immediately after completion of the test. (See Note 1±2.)

9.1.1 An extensometer system shall not be used after an adjustment or repair that could affect its accuracy without first verifying its accuracy utilizing the procedure described in this practice.

NOTE 1±2—If a test is expected to last more than 18 months, it is recommended that the extensometer system be verified immediately before as well as upon completion of the test.

10. Accuracy Assurance Between Verifications

10.1 Some product-testing procedures may require daily, weekly, or monthly spot checks to ascertain that an extensometer, recorder, or display, and so forth, or combinations thereof etc., are capable of producing accurate strain values between the verifications specified in Section 9. Spot checks may be performed on ranges of interest or at strain levels of interest utilizing a verification device that complies with Section 4 for the strain level(s) at which the spot checks are made.

10.2 Check the extensometer gage length (see 5.1).

10.3 Make spot checks of extensometer readings at approximately 10 and 50 % of a range unless otherwise agreed upon or stipulated by the material supplier or user.

10.4 The extensometer gage length and strain measurement errors shall not exceed the allowable errors at the spot check points for the specified class of extensometer. Should errors be greater than allowable at any of the spot check points, the extensometer system is to be completely verified immediately.

10.5 When spot checks are made, a clear, concise record must be maintained as agreed upon between the supplier and the user. The record shall contain gage length and spot check test data; the name, serial number, verification date, verification agency of the verification device(s) used to make spot checks; the name of person making the spot check; and documentation of the regular verification data and schedule.

10.6 The extensometer system shall be considered verified up to the date of the last successful spot check verification provided that the extensometer system is verified in accordance with Section 5 on a regular schedule in accordance with Section 9. Otherwise, spot checks are not valid.

11. Report

11.1 The report shall include the following:

11.1.1 Method of gage length verification used.

11.1.2 Serial numbers and names of the manufacturers of all apparatus used in verifying the extensometer system.

11.1.3 Serial number and name of the manufacturer of the extensometer verified, or if it is an extensometer system composed of separable components, the serial number and manufacturer of each component of the systems verified.

11.1.4 Gage length of the extensometer. For variable gage length extensometers, state the gage lengths verified.

11.1.5 Temperature of the extensometer during verification.

11.1.6 Complete record of the readings of the extensometer and of the verification apparatus.

11.1.7 Calibration factor, if applicable.

11.1.8 Error in gage length for each measurement of gage length.

11.1.9 Error of the extensometer for each extensometer reading and associated resolution for each range (decade).

11.1.10 Class of the extensometer system. If separate classifications are established for various ranges, report the range (or magnification) and strain values associated with each classification.

11.1.11 If the classification applies to bidirectional testing, it shall be so stated. Otherwise, the classification shall be considered to be unidirectional in the direction of normal use (that is, opening for tension testing, closing for compression testing, and so forth).

11.1.12 The name of the person performing the classification and the date it was performed.

11.2 Information to be available upon request shall include the following:

11.2.1 A statement indicating how, by whom, and when the most recent calibration of the apparatus used in verifying the extensometer system was made.

11.2.2 A statement of the errors of the verification apparatus.

11.2.3 Position of the extensometer during verification.

11.2.4 Method of interfacing or attaching the extensometer to the verification device.

APPENDIXES

(Nonmandatory Information)

X1. EXAMPLE OF PROCEDURE FOR VERIFICATION AND CLASSIFICATION OF EXTENSOMETERS

X1.1 An example of a verification report for a 1-in., 50 % extensometer used on a single range testing machine is given in Fig. X1.1.

X1.1.1 The first two columns represent actual (applied) strains through calibration apparatus.

X1.1.2 The next two columns represent the extensometer strain readings from the testing instrument (indicated strain).

X1.1.3 The last four columns represent errors in actual strain (in./in. or m/m) as a percent of reading.

X1.2 Fig. X1.2 shows the accuracy specification for a 1-in., 50 % extensometer, with the errors plotted from an actual verification.

X1.3 Fig. X1.3 is an example of a verification report for the same extensometer shown in Fig. X1.1 but used as a multi-range system (100 % and 10 % ranges).

X1.4 The data for a typical autographic extensometer are given in Fig. X1.4.

EXTENSOMETER VERIFICATION REPORT
XYZ Corporation

PERFORMED FOR: ABC CORP.

DATE: 11-04-1998

XYZ FIELD REPRESENTATIVE: JOE CALIBRATION

EXTENSOMETER

Model: DEF CORP.
Serial No.: 11111
Tens F/S Travel: 0.5000 in (12.7000 mm)
Gage Length: 1.0000 in (25.4000 mm)

MACHINE

Model: DEF CORP.
Serial No.: 22222
Indicators: 1
1-GPIB Interface
Tens F/S Value: 0.5000 in

TEST TYPE: Unidirectional TEMPERATURE: 75 F MACHINE STRAIN CHANNEL: 1

GAGE LENGTH MEASURED (Direct): 1) 0.999 in (25.375 mm), 2) 0.999 in (25.375 mm)
ERROR IN GAGE LENGTH: -0.001 in (-0.025 mm) -----> 0.10%

MACHINE INDICATOR 1: GPIB Interface

100% RANGE

ACTUAL STRAIN (%)		EXTENSOMETER STRAIN (%)		FIXED ERROR in/in (mm/mm)		RELATIVE ERROR (% OF ACT STRAIN)	
RUN 1	RUN 2	RUN 1	RUN 2	RUN 1	RUN 2	RUN 1	RUN 2
+0.000	+0.000	+0.000	+0.000	+0.0000	+0.0000		
+0.506	+0.506	+0.500	+0.510	-.00006	+0.00004	-1.186	+0.790
+1.007	+1.006	+1.010	+1.015	+0.00003	+0.00009	+0.298	+0.895
+2.009	+2.010	+2.015	+2.015	+0.00006	+0.00005	+0.299	+0.249
+3.513	+3.512	+3.525	+3.520	+0.00012	+0.00008	+0.342	+0.228
+5.015	+5.016	+5.035	+5.030	+0.00020	+0.00014	+0.399	+0.279
+10.026	+10.030	+10.050	+10.055	+0.00024	+0.00025	+0.239	+0.249
+20.041	+20.043	+20.090	+20.095	+0.00049	+0.00052	+0.244	+0.259
+35.060	+35.056	+35.105	+35.110	+0.00045	+0.00054	+0.128	+0.154
+50.073	+50.075	+50.155	+50.165	+0.00082	+0.00090	+0.164	+0.180

CALIBRATION FACTOR (Converts Machine Output to Strain Value): 1.001001

RESOLUTION: .00005 in

CLASS OF EXTENSOMETER SYSTEM: B-1

VERIFICATION METHOD: Micrometer in extensometer Calibration Frame.

VERIFICATION APPARATUS:

Micrometer - Make/Model: BRAND X DIGITAL MICROMETER
Serial No.: 33333
Calibration Due: 01-01-1997

***** VERIFICATION PERFORMED PER ASTM STANDARD PRACTICE E83-98 *****

XYZ CORPORATION FURTHER CERTIFIES THAT ITS CALIBRATION APPARATUS IS
TRACEABLE TO NIST STANDARDS.

SIGNATURE OF XYZ FIELD REPRESENTATIVE _____

FIG. X1.1 Extensometer Verification Report

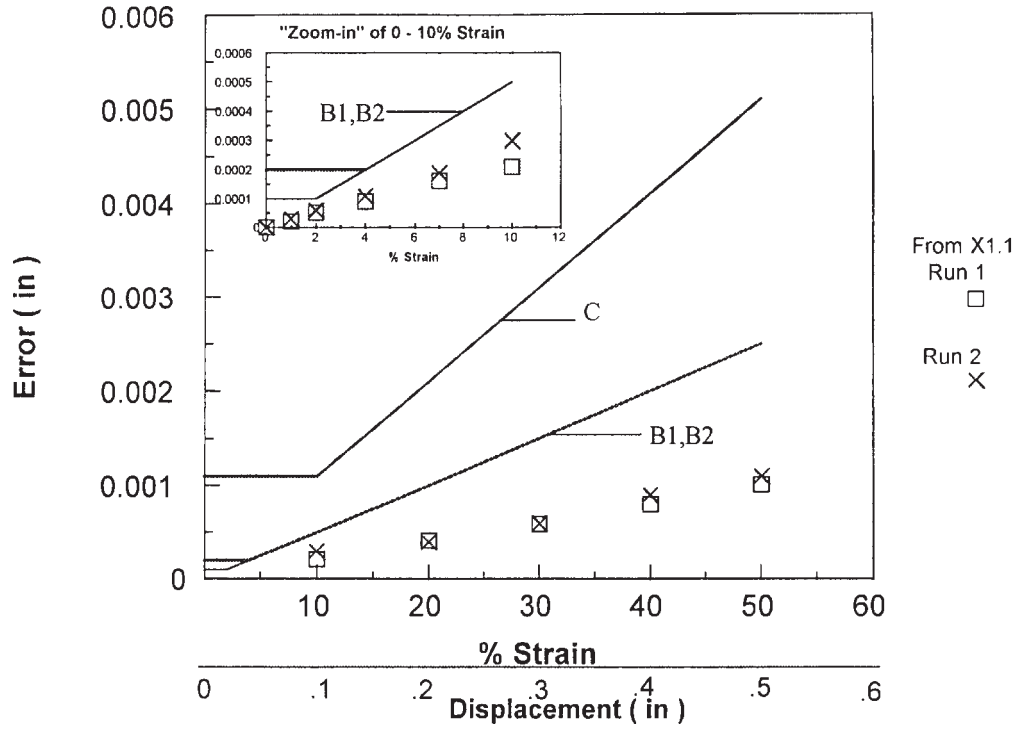

FIG. X1.2 Accuracy Specification for 1 in. 50 % Extensometer

EXTENSOMETER VERIFICATION REPORT FOR A MULTIRANGE SYSTEM
XYZ Corporation

PERFORMED FOR: ABC CORP.

DATE: 11-04-1998

XYZ FIELD REPRESENTATIVE: JOE CALIBRATION

EXTENSOMETER

Model: DEF CORP.
Serial No.: 11111
Tens F/S Travel: 0.5000 in (12.7000 mm)
Gage Length: 1.0000 in (25.4000 mm)

MACHINE

Model: DEF CORP.
Serial No.: 22222
Indicators: 1
1-GPIB Interface
Tens F/S Value: 0.5000 in

TEST TYPE: Unidirectional TEMPERATURE: 75 F MACHINE STRAIN CHANNEL: 1

GAGE LENGTH MEASURED (Direct): 1) 0.999 in (25.375 mm), 2) 0.999 in (25.375 mm)
ERROR IN GAGE LENGTH: -0.001 in (-0.025 mm) -----> 0.10%

MACHINE INDICATOR 1: GPIB Interface

100% RANGE

ACTUAL STRAIN (%)		EXTENSOMETER STRAIN (%)		FIXED ERROR in/in (mm/mm)		RELATIVE ERROR (% OF ACT STRAIN)	
RUN 1	RUN 2	RUN 1	RUN 2	RUN 1	RUN 2	RUN 1	RUN 2
+0.000	+0.000	+0.000	+0.000	+0.00000	+0.00000		
+5.008	+5.010	+5.020	+5.025	+0.00012	+0.00015	+0.239	+0.299
+10.020	+10.022	+10.030	+10.035	+0.00010	+0.00013	+0.100	+0.130
+20.034	+20.035	+20.010	+20.000	+0.00024	+0.00035	-0.120	-0.175
+35.055	+35.056	+35.105	+35.100	+0.00050	+0.00044	+0.142	+0.125
+50.076	+50.075	+50.110	+50.115	+0.00034	+0.00040	+0.068	+0.080

CALIBRATION FACTOR (Converts Machine Output to Strain Value): 1.001001
RESOLUTION: .00005 in CLASS OF EXTENSOMETER SYSTEM: B-1

10% RANGE

ACTUAL STRAIN (%)		EXTENSOMETER STRAIN (%)		FIXED ERROR in/in (mm/mm)		RELATIVE ERROR (% OF ACT STRAIN)	
RUN 1	RUN 2	RUN 1	RUN 2	RUN 1	RUN 2	RUN 1	RUN 2
+0.000	+0.000	+0.000	+0.000	+0.00000	+0.00000		
+0.503	+0.504	+0.505	+0.505	+0.00002	+0.00001	+0.398	+0.198
+1.004	+1.004	+1.008	+1.009	+0.00004	+0.00005	+0.398	+0.498
+2.007	+2.006	+2.015	+2.016	+0.00008	+0.00010	+0.399	+0.499
+3.511	+3.513	+3.528	+3.529	+0.00017	+0.00016	+0.484	+0.455
+5.015	+5.014	+5.039	+5.037	+0.00024	+0.00023	+0.479	+0.459

CALIBRATION FACTOR (Converts Machine Output to Strain Value): 1.001001
RESOLUTION: .00005 in CLASS OF EXTENSOMETER SYSTEM: B-1

VERIFICATION METHOD: Micrometer in extensometer Calibration Frame.

VERIFICATION APPARATUS:

Micrometer - Make/Model: BRAND X DIGITAL MICROMETER
Serial No.: 33333
Calibration Due: 01-01-1997

***** VERIFICATION PERFORMED PER ASTM STANDARD PRACTICE E83-98 *****

XYZ CORPORATION FURTHER CERTIFIES THAT ITS CALIBRATION APPARATUS IS
TRACEABLE TO NIST STANDARDS.

SIGNATURE OF XYZ FIELD REPRESENTATIVE _____

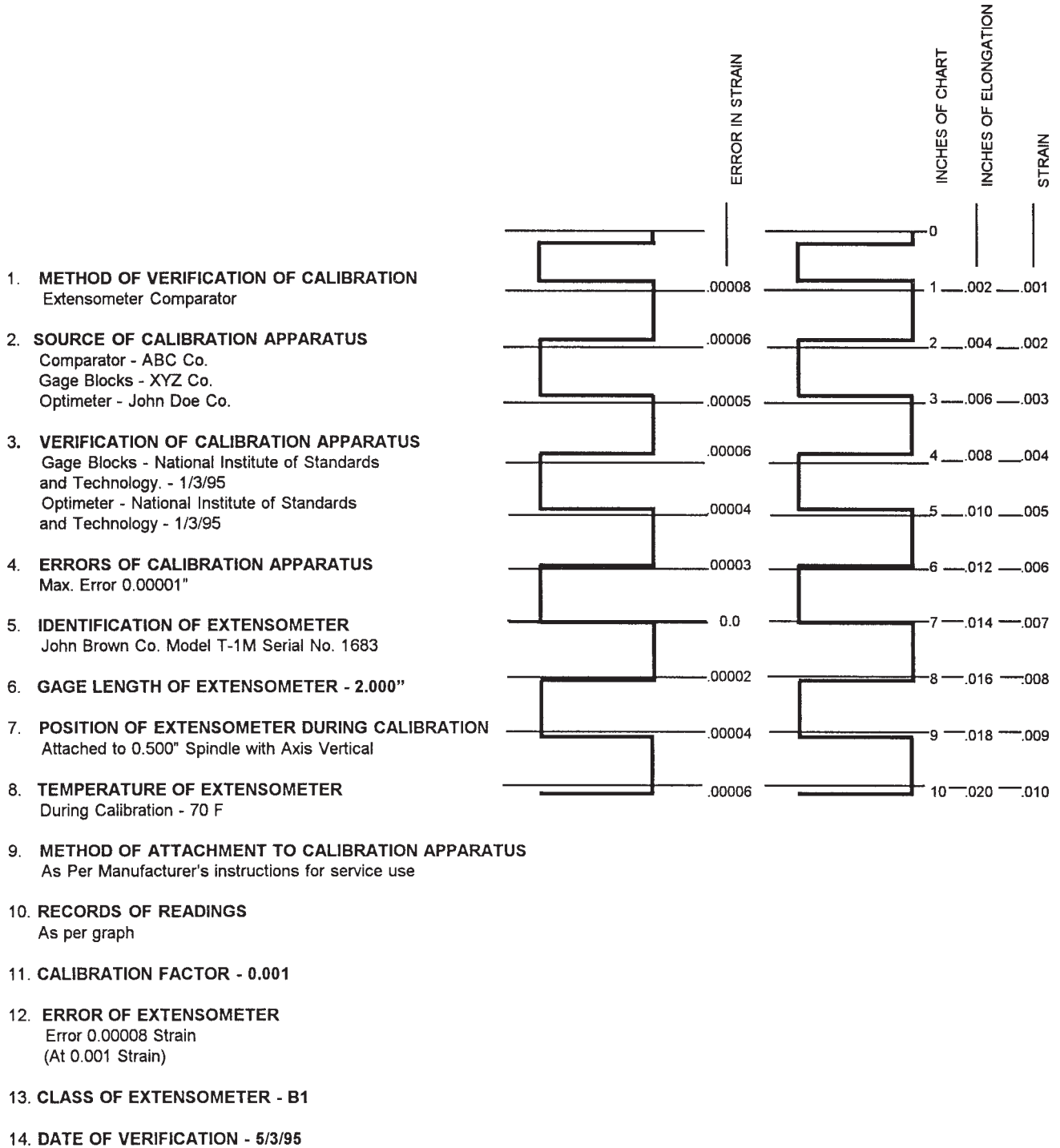

NOTE 1—Error in strain is calculated by measuring the error in chart length and multiplying by the calibration factor.

FIG. X1.4 Typical Record and Report for Extensometers Verified on Autographic Recorders

X2. TEMPERATURE EFFECTS ON EXTENSOMETER CLASSIFICATION

X2.1 Using an extensometer on a test specimen at a temperature other than the temperature at which the verification was performed can cause errors in the strain reading. The source of these errors varies with the type of extensometer being used. It may be due to a shift in the null point of the device, a change in span, or an error in the gage length. See Fig. X2.1.

X2.2 Some common typical sources of error are as follows:

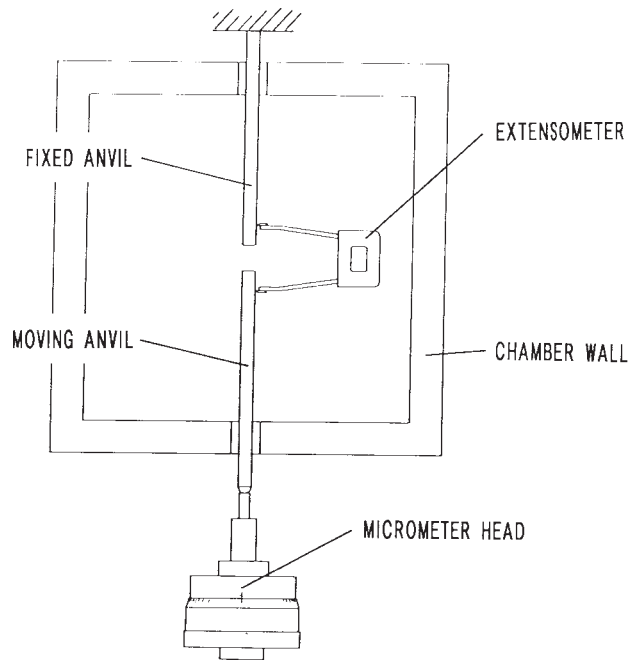

FIG. X2.1 Schematic of Test Set-Up

X2.2.1 *Clip-On Type Extensometers :*

X2.2.1.1 Dimensional changes due to thermal effects giving rise to errors in zero, span, and gage length,

X2.2.1.2 Sensitivity changes as a function of temperature of the transducer being used (that is, strain gages, capacitive devices, LVDTs, etc.) giving span errors,

X2.2.1.3 Shifts in the null point of the transducer being used as a function of temperature,

X2.2.1.4 Sensitivity changes as a function of dielectric changes of the environment, and

X2.2.1.5 Sensitivity changes as a function of modulus change in extensometer arms or element.

X2.2.2 *Non-Contact Type Extensometers :*

X2.2.2.1 Refraction effects due to windows, temperature gradients, or turbulence can cause errors in some type extensometers (for example, scanning beams measuring distance between flags),

X2.2.2.2 Loss of transparency in windows can reduce accuracy,

X2.2.2.3 Changes in speed of light, if not corrected, will cause errors in some laser techniques,

X2.2.2.4 Changes in the surface of the specimen due to oxidation, frosting, corrosion, and so forth, will cause problems with some techniques, and

X2.2.2.5 Radiation emitted by high-temperature specimens or heaters may affect the performance of various optical extensometers.

X2.3 Since there are a wide variety of new extensometry instruments based on new technology, it is impossible to predict or correct, or both, for all possible sources of error when using these methods at high or low temperatures. The only prudent approach is to perform a Practice E 83 type of verification within the environment to be used. It is recommended that the same environmental chamber (furnace or cryostat) be used for the verification that is being used for the material test. This will insure similar thermal and optical conditions exist and, hence, similar effects on the strain measurement should be observed.

X2.4 Examples of methods that could be employed for verification are as follows (also see Test Methods E 21, paragraph 5.4.1).

X2.4.1 *Environmental Effects on Span* —The schematic below shows a clip-on extensometer in an environmental chamber mounted on a split specimen attached to a micrometer head. Although it may be difficult to establish effects on zero (null point) or gage length accuracy, this setup can be used to measure any changes to the span of the device.

X2.4.2 *Effects on the Null Point* —A material of zero or known expansion coefficients can be used to measure the effects of temperature on the null or zero of the extensometer. The device is either mounted on or focused toward (for optical non-contact extensometers) the “dummy” specimen. The known effects of temperature (in the absence of stress) on the material’s dimension can be compared against the measured effect from the extensometer to give a measurement of the change in zero.

X2.4.3 *Effects on Gage Length Accuracy :*

X2.4.3.1 This quantity is more difficult to determine since common methods (as described in this practice) for determining accuracy of gage length are difficult to apply at high or low temperatures.

X2.4.3.2 For example, if an extensometer is “clipped” on a specimen that was immersed in a cryogenic liquid, the accuracy of the gage length setting could be determined at room temperature by conventional methods. The actual low-temperature gage length

would be different since the material would change in length according to its coefficient of expansion characteristics. If these are known and the temperature is known, then the low-temperature gage length can be calculated.

X2.4.3.3 If the null and span characteristics of the extensometer are known, then the change in output of the extensometer (attached to the specimen) as the temperature is lowered will give a direct reading of the thermal characteristics of the material and this output can be used to determine the new gage length.

X2.5 Another possible approach for non-contact type systems is the use of reference specimens. Some of these extensometers measure the distance between “flags” on the specimen at zero load as the gage length. The accuracy of the gage length is dependent on the accuracy of the instrument and does not rely on precise placement of the flags. A possible method to verify this at high temperature is the use of a precision reference specimen with known gage length (placement of marks or flags) and known thermal mechanical properties. This specimen is then placed in the environmental chamber, and the environmental and optical conditions to be used in the test can be reproduced. The gage length can be calculated from the known properties of the reference specimen and compared with the measurement.

X2.6 This appendix is not intended to be a detailed test procedure for verification of the classification of extensometers as a function of all environments. It should be used as a guide to make the user aware of possible errors in strain that result from environmental effects. Manufacturers of extensometers should provide performance characteristics of their instruments under typical operating test conditions. Although this information is seldom adequate to allow the user to ignore errors due to their specific test conditions, it can be used as a starting point for further analysis.

X3. FREQUENCY EFFECTS ON THE CLASSIFICATION OF EXTENSOMETERS

X3.1 The usable bandwidth of extensometers is a function of both mechanical and electrical characteristics. It is naive to perform a static verification as described in Practice E 83 and run dynamic (cyclic) testing and assume that the classification remains unchanged. In general, both the amplitude and phase of the instrument may change as a function of frequency effects. Some examples follow.

X3.1.1 *Mechanical Effects*—If the specimen extensometer system approaches a resonance, there will be shifts in the phase between the input and the resulting strain as well as errors in the amplitude reading. The error in strain amplitude approaching a resonance will be positive, will peak at the resonance (for underdamped systems) and will become a negative error beyond the resonant point. This effect depends not only on the resonant frequency but the Q of the resonance. Extensometers that contain large mechanical elements may have inertial effects which at high frequencies cause forces on the attachment points to the specimen. These forces can lead to slipping of the extensometer which will give errors in strain.

X3.1.2 *Electronic Effects*—Most extensometer systems include electronics which have bandwidths determined by the detail of the design. These should be specified by the manufacturer. They result from the following characteristics:

X3.1.2.1 Response of the readout device. For example, if a chart recorder or XY plotter were being used, then the pen response might be the limiting factor; or if a digital readout device is used, they are often filtered to avoid digit instability. This filter will have a roll-off frequency, which may be the limiting factor of the bandwidth.

X3.1.2.2 For digital instruments the digital sampling rate will affect the bandwidth. Aliasing can also be a factor in digital systems.

X3.1.2.3 On the opposite end of the spectrum long-term drift characteristics must be considered for extensometers to be used in long-term creep testing.

X3.2 *Qualitative Test of Dynamic Performance:*

X3.2.1 There are a number of methods that can be used to check the dynamic performance of an extensometer. These methods, if carefully implemented, would give quantitative information on the dynamic effects on the accuracy of the extensometer. This appendix is not intended to provide specific procedures for a dynamic calibration of an extensometer. An extensometer of known dynamic properties can be used in parallel with the device in question, and a comparison of the results can be made as a function of frequency. A strain-gaged specimen can be used as a reference, or a specimen with known properties could be used to verify the extensometer results.

X3.2.2 It is recommended, however, that as an absolute minimum the test illustrated in Fig. X3.1 be used to check the extensometer over the frequency range of interest. The test conditions (frequency and amplitude) should be applied to the extensometer attached to a single anvil as shown. Ideally, this test should result in zero output over the performance range of interest. Any output under these test conditions will likely cause deviations in the accuracy of the extensometer system as determined by the static verification described in Practice E 83.

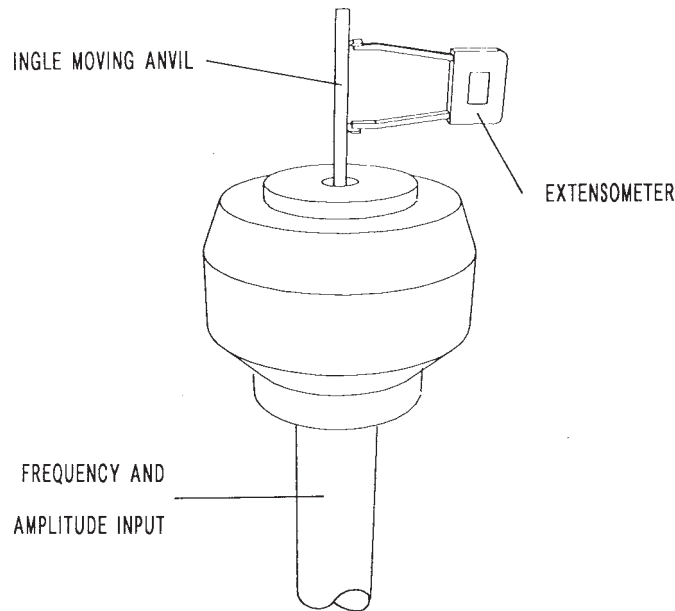

FIG. X3.1 Extensometer on a Single Moving Anvil

ASTM International takes no position respecting the validity of any patent rights asserted in connection with any item mentioned in this standard. Users of this standard are expressly advised that determination of the validity of any such patent rights, and the risk of infringement of such rights, are entirely their own responsibility.

This standard is subject to revision at any time by the responsible technical committee and must be reviewed every five years and if not revised, either reapproved or withdrawn. Your comments are invited either for revision of this standard or for additional standards and should be addressed to ASTM International Headquarters. Your comments will receive careful consideration at a meeting of the responsible technical committee, which you may attend. If you feel that your comments have not received a fair hearing you should make your views known to the ASTM Committee on Standards, at the address shown below.

This standard is copyrighted by ASTM International, 100 Barr Harbor Drive, PO Box C700, West Conshohocken, PA 19428-2959, United States. Individual reprints (single or multiple copies) of this standard may be obtained by contacting ASTM at the above address or at 610-832-9585 (phone), 610-832-9555 (fax), or service@astm.org (e-mail); or through the ASTM website (www.astm.org).