



Standard Test Method for Determining Residual Stresses by the Hole-Drilling Strain- Gage Method¹

This standard is issued under the fixed designation E 837; the number immediately following the designation indicates the year of original adoption or, in the case of revision, the year of last revision. A number in parentheses indicates the year of last reapproval. A superscript epsilon (ϵ) indicates an editorial change since the last revision or reapproval.

INTRODUCTION

The hole-drilling strain-gage method measures residual stresses near the surface of a material. The method involves attaching strain gages to the surface, drilling a hole in the vicinity of the gages, and measuring the relieved strains. The measured strains are then related to relieved principal stresses through a series of equations.

1. Scope

1.1 This test method covers the procedure for determining residual stresses near the surface of isotropic linearly-elastic materials. Although the concept is quite general, the test method described here is applicable in those cases where the stresses do not vary significantly with depth and do not exceed one half of the yield strength. The test method is often described as “semi-destructive” because the damage that it causes is very localized and in many cases does not significantly affect the usefulness of the specimen. In contrast, most other mechanical methods for measuring residual stress substantially destroy the specimen. Since the test method described here does cause some damage, it should be applied only in those cases either where the specimen is expendable or where the introduction of a small shallow hole will not significantly affect the usefulness of the specimen.

1.2 *This standard does not purport to address all of the safety concerns, if any, associated with its use. It is the responsibility of the user of this standard to establish appropriate safety and health practices and determine the applicability of regulatory limitations prior to use.*

2. Referenced Documents

2.1 ASTM Standards:

E 251 Test Methods for Performance Characteristics of Metallic Bonded Resistance Strain Gages²

¹ This test method is under the jurisdiction of ASTM Committee E-28 on Mechanical Testing and is the direct responsibility of Subcommittee E28.13 on Residual Stress Measurement.

Current edition approved Oct. 10, 1999. Published April 2000. Originally published as E 837 – 81. Last previous edition E 837 – 95.

² *Annual Book of ASTM Standards*, Vol 03.01.

3. Summary of Test Method

3.1 A strain gage rosette with three or more elements of the general type schematically illustrated in Fig. 1 is placed in the area under consideration. The numbering scheme for the strain gages follows a clockwise (CW) convention (**1**).³

NOTE 1—The gage numbering convention used for the rosette illustrated in Fig. 1 differs from the counter-clockwise (CCW) convention used for some designs of general-purpose strain gage rosettes and for some other types of residual stress rosette. If a strain gage rosette with CCW gage numbering is used, the residual stress calculation methods described in this test method still apply. The only change is a reversal in the assignment of the direction of the most tensile principal stress. This change is described in Note 7. All other aspects of the residual stress calculation are unaffected.

3.2 A hole is drilled at the geometric center of the strain gage rosette to a depth of about 0.4 of the mean diameter of the strain gage circle, D.

3.2.1 The residual stresses in the area surrounding the drilled hole relax. The relieved strains are measured with a suitable strain-recording instrument. Within the close vicinity of the hole, the relief is nearly complete when the depth of the drilled hole approaches 0.4 of the mean diameter of the strain gage circle, D.

3.3 Fig. 2 shows a schematic representation of the residual stress and a typical surface strain relieved when a hole is drilled into a material specimen. The surface strain relief is related to the relieved principal stresses by the following relationship:

$$\epsilon_r = (\bar{A} + \bar{B} \cos 2\beta)\sigma_{\max} + (\bar{A} - \bar{B} \cos 2\beta)\sigma_{\min} \quad (1)$$

³ The boldface numbers in parentheses refer to the list of references at the end of this test method.

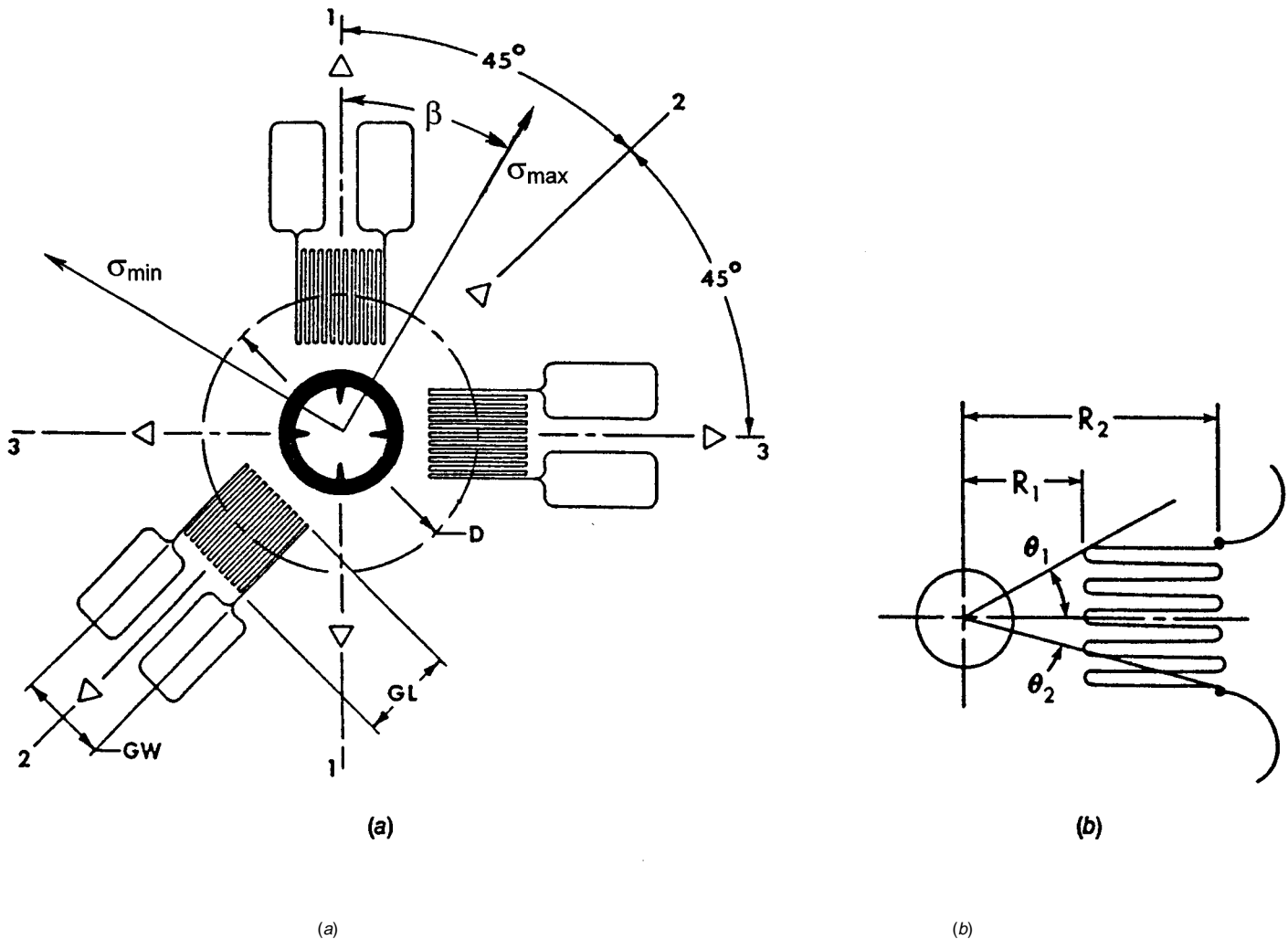

FIG. 1 Schematic Diagram Showing the Geometry of a Typical Three-Element Clockwise (CW) Strain Gage Rosette for the Hole-Drilling Method

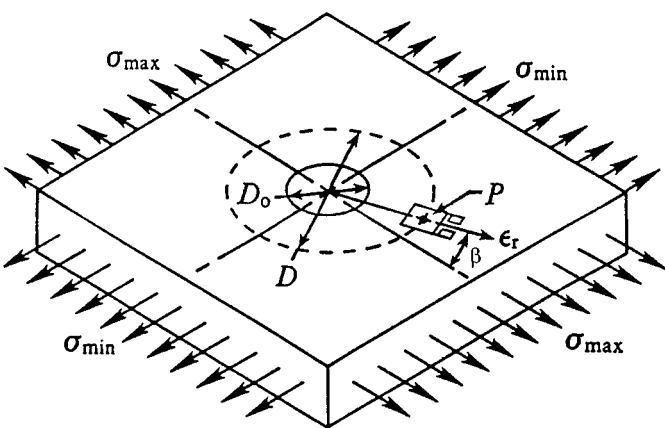

FIG. 2 Definitions of Symbols

where:
 ϵ_r = relieved strain measured by a radially aligned strain gage centered at P,
 \bar{A}, \bar{B} = calibration constants,
 σ_{max} = maximum (most tensile) and

σ_{min} = minimum (most compressive) principal stresses present at the hole location before drilling,
 β = angle measured clockwise from the direction of gage 1 to the direction of σ_{max} ,
 D = diameter of the gage circle,
 D_0 = diameter of the drilled hole.

3.3.1 The following equations may be used to evaluate the constants \bar{A} and \bar{B} for a material with given elastic properties:

$$\bar{A} = -\bar{a}(1+\nu)/(2E) \tag{2}$$

$$\bar{B} = -\bar{b}/(2E) \tag{3}$$

where:
 E = Young's modulus,
 ν = Poisson's ratio, and

\bar{a} and \bar{b} are dimensionless, almost material-independent constants (see Note 2). Slightly different values of these constants apply for a through-thickness hole made in a thin specimen and for a blind hole made in a thick specimen. The numerical values of these constants are provided in this test method.

NOTE 2—The dimensionless coefficients \bar{a} and \bar{b} vary with hole depth, as indicated in Table 1. They are both nearly material-independent. They do not depend on Young’s modulus, E , and they vary by less than 1 % for Poisson’s ratios in the range 0.28 to 0.33. For a through-hole in a thin plate, \bar{a} is independent of Poisson’s ratio.

3.3.2 The relieved strains ϵ_1 , ϵ_2 , and ϵ_3 are measured by three correspondingly numbered strain gages as shown in Fig. 1. For specialized applications, a rosette with three pairs of strain gages arranged in directions 1 - 2 - 3 may be used (see 5.2.3). Measurement of these three relieved strains provides sufficient information to calculate the principal stresses σ_{\max} and σ_{\min} and their orientation β .

3.3.3 For reasons of pictorial clarity in Fig. 2, the principal residual stresses σ_{\max} and σ_{\min} are shown as uniformly acting over the entire region around the hole location. In actuality, it is not necessary for the residual stresses to be uniform over such a large region. The relieved surface strains depend only on the principal stresses that originally existed at the boundaries of the hole (2). The stresses beyond the hole boundaries do not affect the relieved strains. Because of this, the hole-drilling method provides a very localized measurement of residual stresses.

3.3.4 It is assumed that the variations of the original stresses within the boundaries of the hole are small and that the variation with depth is negligible. It is not necessary for the original stresses outside of the hole location to be uniform.

4. Significance and Use

4.1 Residual stresses are present in almost all structures. They may be present as a result of manufacturing processes or they may occur during the life of the structure. In many cases residual stresses are a major factor in the failure of a structure, particularly one subjected to alternating service loads or corrosive environments. Residual stress may also be beneficial as, for example, compressive stresses produced by shot peening. The hole-drilling strain-gage technique is a practical method for determining residual stresses.

5. Strain Gages

5.1 A rosette comprising three single or pairs of strain gage grids shall be used.

NOTE 3—It is recommended that the gages be calibrated in accordance with Test Methods E 251.

5.1.1 The gages shall be arranged in a circular pattern,

TABLE 1 Numerical Values of Coefficients \bar{a} and \bar{b}

Rosette A	\bar{a}					\bar{b}				
Blind hole	Hole Diameter, D_0/D					Hole Diameter, D_0/D				
Depth/D	0.30	0.35	0.40	0.45	0.50	0.30	0.35	0.40	0.45	0.50
0.00	.000	.000	.000	.000	.000	.000	.000	.000	.000	.000
0.05	.027	.037	.049	.063	.080	.051	.069	.090	.113	.140
0.10	.059	.081	.108	.138	.176	.118	.159	.206	.255	.317
0.15	.085	.115	.151	.192	.238	.180	.239	.305	.375	.453
0.20	.101	.137	.177	.223	.273	.227	.299	.377	.459	.545
0.25	.110	.147	.190	.238	.288	.259	.339	.425	.513	.603
0.30	.113	.151	.195	.243	.293	.279	.364	.454	.546	.638
0.35	.113	.151	.195	.242	.292	.292	.379	.472	.566	.657
0.40	.111	.149	.192	.239	.289	.297	.387	.482	.576	.668
Through Hole	.090	.122	.160	.203	.249	.288	.377	.470	.562	.651
Rosette B	\bar{a}					\bar{b}				
Blind Hole	Hole Diameter, D_0/D					Hole Diameter, D_0/D				
Depth/D	0.30	0.35	0.40	0.45	0.50	0.30	0.35	0.40	0.45	0.50
0.00	.000	.000	.000	.000	.000	.000	.000	.000	.000	.000
0.05	.029	.039	.053	.068	.086	.058	.078	.102	.127	.157
0.10	.063	.087	.116	.148	.189	.134	.179	.231	.286	.355
0.15	.090	.123	.162	.205	.254	.203	.269	.343	.419	.504
0.20	.107	.145	.189	.236	.289	.256	.336	.423	.511	.605
0.25	.116	.156	.202	.251	.305	.292	.381	.476	.571	.668
0.30	.120	.160	.206	.256	.309	.315	.410	.509	.609	.707
0.35	.120	.160	.206	.256	.308	.330	.427	.529	.631	.730
0.40	.118	.158	.203	.253	.305	.337	.437	.541	.644	.743
Through Hole	.096	.131	.171	.216	.265	.329	.428	.531	.630	.725
Rosette C	\bar{a}					\bar{b}				
Blind Hole	Hole Diameter, D_0/D					Hole Diameter, D_0/D				
Depth/D	0.40	0.45	0.50	0.55	0.60	0.40	0.45	0.50	0.55	0.60
0.00	.000	.000	.000	.000	.000	.000	.000	.000	.000	.000
0.05	.065	.084	.106	.130	.157	.105	.132	.158	.185	.217
0.10	.147	.191	.238	.293	.361	.250	.314	.373	.440	.519
0.15	.218	.281	.347	.420	.506	.391	.484	.570	.658	.754
0.20	.270	.343	.421	.504	.595	.506	.617	.719	.816	.912
0.25	.302	.381	.465	.554	.648	.591	.712	.823	.923	1.015
0.30	.321	.403	.491	.583	.679	.650	.778	.893	.994	1.081
0.35	.331	.415	.505	.599	.698	.690	.822	.939	1.041	1.125
0.40	.336	.421	.512	.608	.709	.719	.851	.970	1.073	1.154
Through Hole	.316	.399	.494	.597	.707	.623	.723	.799	.847	.859

equidistant from the center of the rosette.

5.1.2 The principal gage axes shall be oriented in each of three directions, (1) a reference direction, (2) 45° or 135° to the reference direction, and (3) perpendicular to the reference direction. Direction (2) bisects directions (1) and (3), (see Fig. 1).

5.2 Several different standardized rosettes are available to meet a wide range of residual stress measurement needs.⁴ Fig. 3 shows three different rosette types.

5.2.1 Fig. 3 (a) shows the type A rosette, first introduced by Rendler and Vigness (3). This pattern is available in several different sizes, and is recommended for general-purpose use.

5.2.2 Fig. 3 (b) shows the type B rosette. This pattern has all strain gage grids located on one side. It is useful where measurements need to be made near an obstacle.

5.2.3 Fig. 3 (c) shows the type C rosette. This special-purpose pattern has three pairs of opposite strain gage grids that are to be connected as three half-bridges. It is useful where large strain sensitivity and high thermal stability are required (19).

NOTE 4—Standardized hole-drilling rosette patterns were first proposed by Rendler and Vigness (3). The use of standardized rosette designs greatly simplifies the calculation of the residual stresses.

5.3 The center of the gage circle shall be clearly identifiable both before and after the drilling operation.

5.4 The application of the strain gage (cementing, wiring, protective coating) shall closely follow the manufacturer's recommendations, and shall ensure the protection of the strain gage grid during the drilling operation.

5.5 The strain gages shall remain permanently connected and the stability of the installation shall be verified. A resistance to ground of at least 20 000 MΩ is preferable.

6. Instrumentation

6.1 The instrumentation for recording of strains shall have a strain resolution of $\pm 2 \times 10^{-6}$, and stability and repeatability of the measurement shall be at least $\pm 2 \times 10^{-6}$. The lead wires from each gage should be as short as practicable and a three-wire temperature-compensating circuit (4) should be used with rosette types A and B. Half-bridge circuits should be used with rosette type C, the resulting outputs of which are designated ϵ_1 , ϵ_2 , and ϵ_3 .

NOTE 5—In general, surface preparation should be restricted to those methods which have been demonstrated to induce no significant residual surface stresses.

7. Specimen Preparation

7.1 The surface preparation prior to cementing the strain gage shall conform to the recommendations of the manufacturer of the cement used to attach the strain gage.

7.1.1 A thorough cleaning and degreasing is required.

7.1.2 A smooth surface is usually necessary for strain gage application. However, abrading or grinding that could appreciably alter the surface stresses must be avoided.

Type A

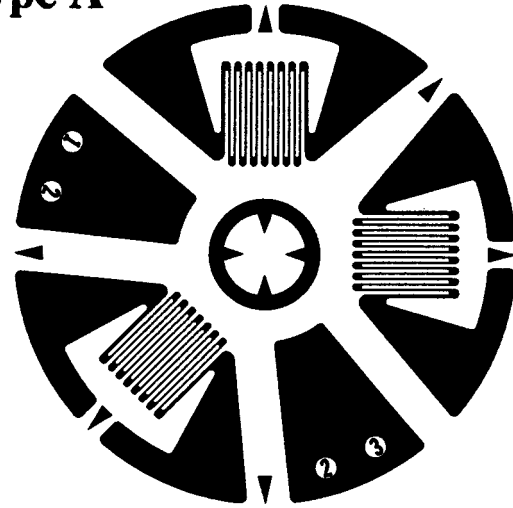

Type B

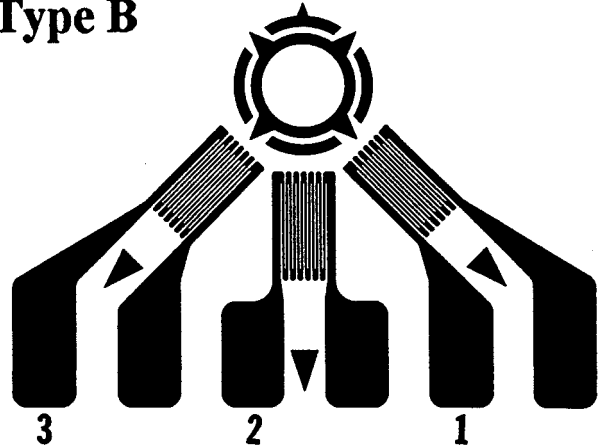

Type C

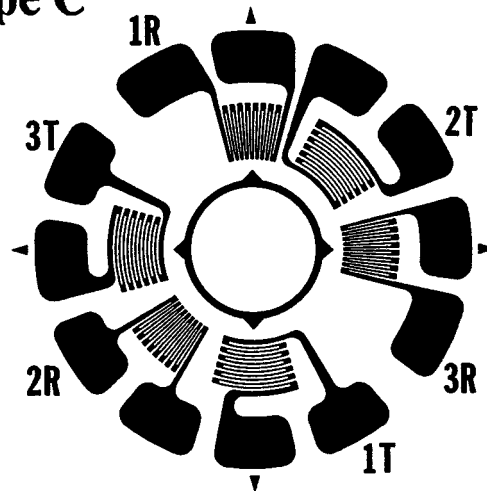

FIG. 3 Hole-Drilling Rosettes

⁴ Strain gage patterns of these designs are manufactured by Measurements Group, Wendell, NC.

8. Procedure

8.1 Drilling:

8.1.1 To protect the strain gage grids, a margin of at least 0.012 in. (0.30 mm) should be allowed between the hole boundary and the end loops of the strain gage grids. The need for this margin limits the maximum allowable diameter, D_0 of the drilled hole. The minimum recommended hole diameter is 60 % of the maximum allowable diameter. Table 2 lists the recommended hole diameter ranges for several common strain gage rosette types.

NOTE 6—As the ratio D_0 / D increases, the sensitivity of the method increases in approximate proportion to $(D_0 / D)^2$. In general, larger holes are recommended because of the increased sensitivity.

8.1.2 The center of the drilled hole shall coincide with the center of the strain gage circle to within either $\pm 0.004 D$ or ± 0.001 in. (± 0.025 mm), whichever is greater. Errors due to misalignment of the drilled hole could produce significant errors in the calculated stress. To avoid these errors, it is recommended that an optical device be used for centering the tool holder. A device suitable for this is shown in Fig. 4.⁵

8.1.3 Select the drilling operation and tool to minimize or eliminate the introduction of plastic deformation in the area surrounding the drilled hole.

8.1.3.1 Several drilling techniques have been investigated and reported to be suitable for the hole drilling method:

(1) Abrasive jet machining,⁶ a method for hole drilling in which a high-velocity stream of air containing fine abrasive particles is directed against the workpiece through a small-diameter nozzle, has been used successfully (5, 6). However, this technique may not be suitable for softer materials such as copper (7).

⁵ A device for centering the tool is manufactured by Measurements Group, Wendell, NC.

⁶ Tools for abrasive jet machining may be obtained from S. S. White, Piscataway, NJ.

(2) Drilling at very high speed (up to 400 000 rpm) with an air turbine has also been used successfully in this application (8). This technique is believed to be generally suitable except for extremely hard materials such as stellite (7).

(3) End mills, carbide drills, and modified end mills have been used successfully in a number of studies (3, 9, 10, 11). It appears, however, that low-speed drilling with an end mill may be less suitable than abrasive jet machining or high-speed drilling (7).

Since any residual stress created by the selected drilling method will adversely affect the accuracy of results, a verification of the selected process is recommended when no prior experience is available. Such verification could consist of applying a strain gage rosette, identical to the rosette used in the test, to a stress-free specimen of the same nominal composition, and then drilling a hole. If the drilling method is satisfactory, the stresses produced by drilling will be small.

NOTE 7—The most commonly used approach to obtaining stress-free specimens is the annealing heat treatment method (5, 6, 7, 15, 16). Recent research (18) suggests that electric discharge machining may also merit consideration as a means for removing small stress-free samples from bulk materials. As a general rule, the smaller the sample, the smaller the residual macrostresses that the sample will be able to sustain although it must, of course, be compatible with the size of the strain gage rosette.

NOTE 8—If the drilling method generates measurable levels of residual stress which are reproducible, experimental calibration should be considered (see 9.3).

8.1.3.2 When end mills are used, proceed with the drilling using very light axial thrust and slowly, to permit ample time for heat dissipation.

8.1.4 Carry out the hole drilling test at constant temperature.

8.2 Obtain zero readings from each gage before starting the drilling operation. Then, commence drilling using one of the following two procedures, depending on the thickness of the material specimen.

8.2.1 A specimen whose thickness is at least 1.2D is considered to be "thick." For such a specimen, obtain eight sets

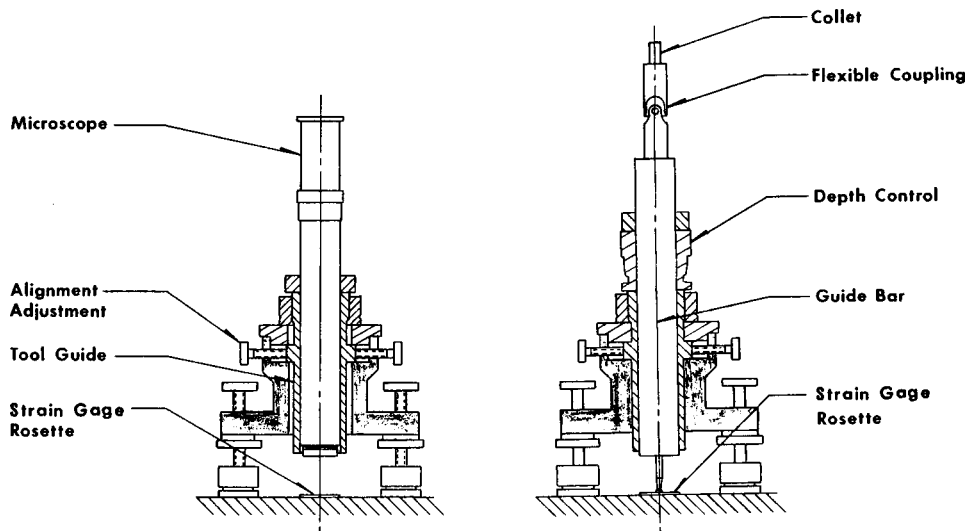

(a) Alignment—Tool guide aligned with the center of gage circle

(b) Hole Milling—After removing the alignment microscope, the drilling tool is introduced

FIG. 4 A Device for Centering the Tool Holder

TABLE 2 Rosette Dimensions and Recommended Hole Diameters^A

Rosette Type ^B	D	GL	GW	R ₁	R ₂	Min D ₀	Max D ₀ ^C
Type A Rosette							
Conceptual	D	0.309 D	0.309 D	0.3455 D	0.6545 D	0.6 Max D ₀	Max D ₀
1/32 in. nominal	0.101 (2.57)	0.031 (0.79)	0.031 (0.79)	0.035 (0.89)	0.066 (1.68)	0.024 (0.61)	0.040 (1.01)
1/16 in. nominal	0.202 (5.13)	0.062 (1.59)	0.062 (1.59)	0.070 (1.77)	0.132 (3.36)	0.060 (1.52)	0.100 (2.54)
1/8 in. nominal	0.404 (10.26)	0.125 (3.18)	0.125 (3.18)	0.140 (3.54)	0.264 (6.72)	0.132 (3.35)	0.220 (5.59)
Type B Rosette							
Conceptual	D	0.309 D	0.223 D	0.3455 D	0.6545 D	0.6 Max D ₀	Max D ₀
1/16 in. nominal	0.202 (5.13)	0.062 (1.59)	0.045 (1.14)	0.070 (1.77)	0.132 (3.36)	0.060 (1.52)	0.100 (2.54)
Type C Rosette							
Conceptual	D	0.176 D	30° sector	0.412 D	0.588 D	0.6 Max D ₀	Max D ₀
1/16 in. nominal	0.170 (4.32)	0.030 (0.76)	30° (30°)	0.070 (1.78)	0.100 (2.54)	0.060 (1.52)	0.100 (2.54)

^ADimensions are in inches. Dimensions in parentheses are in mm.

^BRosette dimensions defined in Fig. 1.

^CFrom 8.1.1.

of strain readings $\epsilon_1, \epsilon_2, \epsilon_3$, as the hole depth is increased in increments of 0.05D, up to a final hole depth of 0.4D. Other similar depth increments are acceptable; however, they are less convenient for calculations because they will require additional interpolation or extrapolation of the calibration constants in Table 1.

8.2.2 A specimen whose thickness is less than 0.4D is considered to be “thin.” For such a specimen, obtain one set of strain readings $\epsilon_1, \epsilon_2, \epsilon_3$, after a hole has been drilled through the entire thickness of the specimen.

8.2.3 The intermediate case when the specimen thickness is between 0.4D and 1.2D is not within the scope of this Standard Test Method. An approximate result can be obtained for such specimens by using a through hole and interpolating the “Blind Hole” and “Through-the-thickness Hole” calibration data given in Table 1. Residual stress results obtained in this way should be reported as “nonstandard” and “approximate.”

8.3 Compute the following combination strains for each set of measured strains $\epsilon_1, \epsilon_2, \epsilon_3$:

$$p = (\epsilon_3 + \epsilon_1) / 2 \quad (4)$$

$$q = (\epsilon_3 - \epsilon_1) / 2 \quad (5)$$

$$t = (\epsilon_3 + \epsilon_1 - 2 \epsilon_2) / 2 \quad (6)$$

8.3.1 When working with a “thick” specimen, a test should be made to check that the residual stresses are uniform within the hole depth. In this case, identify the numerically larger set of combination strains q or t . Express each set of combination strains p and the larger of q and t as a percentage of their values when the hole depth = 0.4 D. Plot these percent strains versus (hole depth/D). These graphs should yield data points very close to the curves shown in Fig. 5 (12). Data points that are removed from the curves in Fig. 5 by more than $\pm 3\%$ indicate either substantial stress nonuniformity through the material thickness, or strain measurement errors. In either case, the measured data are not acceptable for residual stress calcula-

tions using the procedure described here. Other publications, for example, Ref (21), give details of methods for evaluating nonuniform residual stresses from incremental hole-drilling strain data. However, such calculations do not fall within the scope of this test method.

NOTE 9—This graphical test is not a sensitive indicator of stress field uniformity. Specimens with significantly non-uniform stress fields can yield percentage relieved strain curves substantially similar to those shown in Fig. 5. The main purpose of the test is to identify grossly non-uniform stress fields and also strain measurement errors. This stress uniformity test is available only when working with “thick” specimens.

9. Computation of Stresses

9.1 Thin Specimen:

9.1.1 In the case of a “thin” specimen, only a single set of ϵ_1, ϵ_2 , and ϵ_3 measurements is needed to calculate the magnitude and directions of the principal residual stresses. These stresses are assumed to be uniform through the specimen thickness.

9.1.2 The more tensile (or less compressive) principal stress σ_{\max} is located at an angle β measured clockwise from the direction of gage 1 in Fig. 1. Similarly, the less tensile (or more compressive) principal stress σ_{\min} is located at an angle β measured clockwise from the direction of gage 3.

9.1.3 Compute the angle β from

$$\beta = \frac{1}{2} \arctan (t/q) \quad (7)$$

9.1.4 Direct calculation of the angle β using the common one-argument arctan function, such as is found on an ordinary calculator, can give an error of $\pm 90^\circ$. The correct angle can be found by using the two-argument arctan function (function ATAN2 in some computer languages), where the signs of the numerator and denominator are each taken into account. Alternatively, the result from the one-argument calculation can be adjusted by $\pm 90^\circ$ as necessary to place β within the

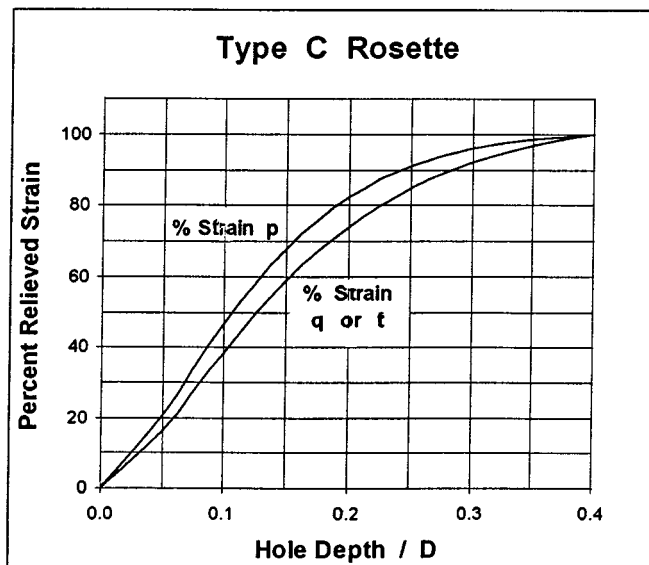
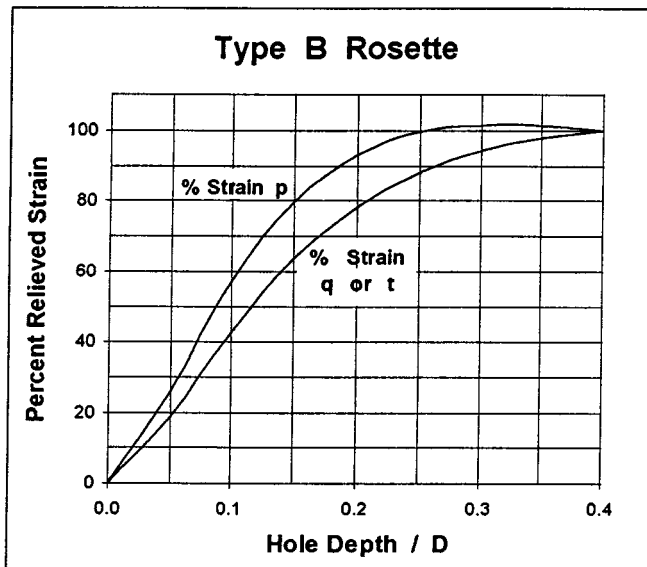
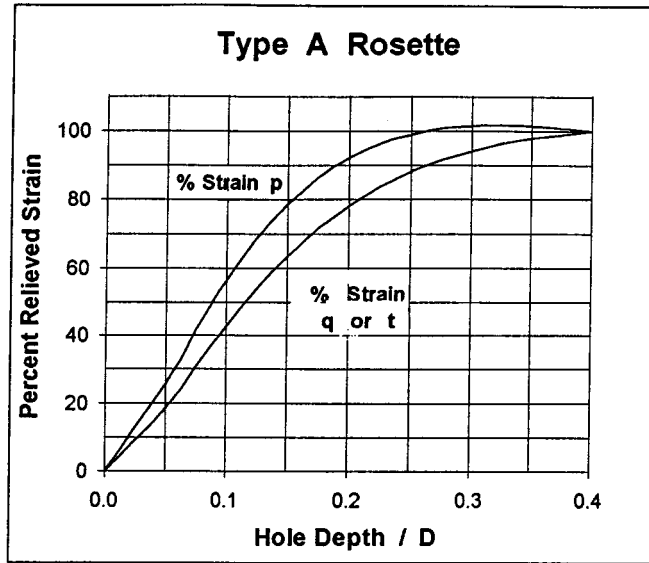

FIG. 5 Typical Plots of Percent of Strain versus Depth for Stress Uniform Through the Thickness, (a) Type A Rosette, (b) Type B Rosette, (c) Type C Rosette

appropriate range defined in the following table:

	$q = < 0$	$q = 0$	$q > 0$
$t > 0$	$45^\circ < \beta < 90^\circ$	45°	$0^\circ < \beta < 45^\circ$
$t = 0$	90°	undefined	0°
$t < 0$	$-90^\circ < \beta < -45^\circ$	-45°	$-45^\circ < \beta < 0^\circ$

9.1.5 A positive value of β , say $\beta = 30^\circ$, indicates that σ_{\max} lies 30° clockwise of the direction of gage 1. A negative value of β , say $\beta = -30^\circ$, indicates that σ_{\max} lies 30° counter-clockwise of the direction of gage 1.

9.1.6 In general, the direction of σ_{\max} will closely coincide with the direction of the numerically most negative (compressive) relieved strain. The case where both $q = 0$ and $t = 0$ corresponds to an equal biaxial stress field, for which the angle β has no meaning.

NOTE 10—The clockwise measurement direction for angle β defined in 9.1.2 applies only to a strain gage rosette with CW gage numbering, such as that illustrated in Fig. 1. The opposite measurement direction for β applies to a CCW strain gage rosette. In such a rosette the geometrical locations of gages 1 and 3 are interchanged relative to the CW case. The new gage 1 becomes the reference gage. For a CCW rosette, a positive value of β , say $\beta = 30^\circ$, indicates that σ_{\max} lies 30° counter-clockwise of the direction of gage 1. A negative value of β , say $\beta = -30^\circ$, indicates that σ_{\max} lies 30° clockwise of the direction of gage 1. All other aspects of the residual stress calculation are identical for both CW and CCW rosettes.

9.1.7 Compute the stresses σ_{\max} and σ_{\min} from

$$\sigma_{\min}, \sigma_{\max} = - [p/\bar{a}(1+\nu) \pm \sqrt{(q^2+t^2)/\bar{b}}]E \quad (8)$$

The negative square root in this equation is associated with σ_{\max} because the leading minus sign on the right of Eq 8. A tensile (+) residual stress will produce a compressive (–) relieved strain.

9.1.8 Use Table 1 to determine the numerical values of the calibration constants \bar{a} and \bar{b} corresponding to the hole diameter and type of rosette used.

9.2 “Thick” Specimen:

9.2.1 In the case of a “thick” specimen, all sets of $\epsilon_1, \epsilon_2, \epsilon_3$ measurements are used to calculate the magnitude and directions of the principal residual stresses. These stresses are assumed to be uniform throughout the hole depth.

NOTE 11—It is possible to do a calculation similar to that described in 9.1 using only one set of the $\epsilon_1, \epsilon_2, \epsilon_3$ measurements, say the values at 0.4D. Such a calculation could be useful to give a quick residual stress estimate; however, the averaging method described in 9.2 is preferred because it uses all the measured strain data, and it significantly reduces the effects of random strain measurement errors.

9.2.2 For each of the hole depths corresponding to the eight sets of $\epsilon_1, \epsilon_2, \epsilon_3$ measurements, use Table 1 to determine the numerical values of the calibration constants \bar{a} and \bar{b} corresponding to the hole diameter and type of rosette used. The numerical values in this table derive from finite element analyses (17) and are found to be in excellent agreement with experimental results.

9.2.3 Compute the three combination stresses P, Q and T corresponding to the three combination strains p, q , and t using the following formulas (20):

$$P = -E \times (\Sigma \bar{a} \cdot p) / (\Sigma \bar{a}^2) / (1 + \nu) \quad (9)$$

$$Q = -E \times (\Sigma \bar{b} \cdot q) / (\Sigma \bar{b}^2) \quad (10)$$

$$T = -E \times (\Sigma \bar{b} \cdot t) / (\Sigma \bar{b}^2) \quad (11)$$

where Σ indicates a summation of the indicated quantities for the eight hole depths.

9.2.4 Compute the angle β from:

$$\beta = \frac{1}{2} \arctan (-T / -Q) \quad (12)$$

$$= \frac{1}{2} \arctan (\Sigma \bar{b} \cdot t / \Sigma \bar{b} \cdot q)$$

Angle β can be placed in the correct quadrant by evaluating the “arctan” function in a manner analogous to that described in 9.1.3.

9.2.5 Compute the stresses σ_{\max} and σ_{\min} from:

$$\sigma_{\max}, \sigma_{\min} = P \pm \sqrt{Q^2 + T^2} \quad (13)$$

9.3 Experimental Calibration:

9.3.1 If required, the constants \bar{a} and \bar{b} relating the stresses σ_{\max} and σ_{\min} to the measured strains ϵ_i can be established using a calibration experiment.

When making calibrations for a “thin” specimen (thickness less than 0.4D), use the same thickness as the actual test specimen. When making calibrations for a “thick specimen”, a thickness, T , of 1.2D or greater is required.

9.3.2 Before drilling the hole, apply the calibration force in five equal steps up to the maximum force. This maximum force should not produce a stress σ_{cal} larger than one-third of the yield stress of the test material.

9.3.3 Compute the combination strains p, q , and t corresponding to the measured strains of ϵ_1, ϵ_2 and ϵ_3 using Eq 4-6. Plot graphs of p, q , and t versus the applied stresses. These graphs should be straight lines. Determine their gradients gp, gq , and gt .

9.3.4 When working with a “thin” specimen, drill a through-hole and repeat the strain measurements for a sequence of five equal loading steps up to the maximum force.

9.3.5 When working with a “thick” specimen, drill a blind hole in a series of eight hole depth increments of 0.05D up to a maximum of 0.4D. After each hole depth increment, repeat the strain measurements for a sequence of five equal loading steps up to the maximum force.

9.3.6 Subtract the p, q , and t gradients measured before any hole drilling from the corresponding gradients at each hole depth:

$$(gp)_{\text{cal}} = (gp)_{\text{hole}} - (gp)_{\text{before}} \quad (14)$$

$$(gq)_{\text{cal}} = (gq)_{\text{hole}} - (gq)_{\text{before}} \quad (15)$$

$$(gt)_{\text{cal}} = (gt)_{\text{hole}} - (gt)_{\text{before}} \quad (16)$$

The calibrated values of constants \bar{a} and \bar{b} for the eight depths to be used in equations (9) – (12) are:

$$\bar{a} = 2(gp)_{\text{cal}} \times E / (1 + \nu) \quad (17)$$

$$\bar{b} = 2 \sqrt{((gp)_{\text{cal}})^2 + (gt)_{\text{cal}}^2} \times E \quad (18)$$

10. Report

10.1 Report the following information:

10.1.1 Description of the test specimen,

10.1.1.1 Material,

10.1.1.2 Pertinent mechanical properties,

- 10.1.2 Location of strain gages,
- 10.1.3 Model and type of strain gages used,
 - 10.1.3.1 Strain gage geometry,
- 10.1.4 The method used to drill the hole,
- 10.1.5 Plot of strain versus depth for each gage,
- 10.1.6 Tabulation of strains ϵ_1 , ϵ_2 , and ϵ_3 at all locations, and
- 10.1.7 Tabulation of stresses and direction of stresses at all locations.

11. Precision and Bias

11.1 Bias:

11.1.1 Residual stresses determined by this method may be expected to exhibit a bias not exceeding $\pm 10\%$ provided that the conditions set forth in 1.1 apply and the drilling technique does not induce significant machining stresses in the material (6, 15). The most elusive of these conditions may be the requirement that the residual stresses not vary significantly with depth. Residual stresses are commonly induced by various working, forming, welding, and other manufacturing processes which involve the application of energy to and through the surface of the object. As a result, there are usually stress gradients near the surface, and a depthwise uniform residual stress is apt to be rarely encountered. If a significant nonuniform stress distribution goes unrecognized, the error may be much more than 10%, and will usually be in the direction of underestimating the maximum stress.

11.2 Precision:

11.2.1 A round-robin test program (16) was carried out on AISI 1018 carbon-steel specimens that had been subjected to a prior stress relief treatment. High-speed, low-speed, and air

abrasive drilling were used. In all, measurements were made by eight laboratories on eight nominally identical specimens, giving a standard deviation of 2.0 ksi (14 MPa) about the mean of all 26 measurements.

11.2.2 A round-robin test program (17) was carried out on type 304 stainless steel specimens that had been subjected to a prior stress relief treatment. In all, 46 nominally identical specimens were tested by 35 laboratories using a variety of methods. Forty-six residual stress measurements, made using high-speed drilling and air abrasive drilling, produced standard deviations that did not exceed 1.7 ksi (12 MPa) about the mean of either drilling technique. Results of six measurements made using low-speed drilling were not consistent.

11.2.3 The variability of results obtained on stressed specimens may be expected to be considerably greater than that observed on specimens that are relatively stress free. A round-robin test program on stressed stainless steel specimens is being planned by the Residual Stress Technical Division of the Society for Experimental Mechanics with participation by ASTM Subcommittee E28.13.

11.2.4 Evaluations of the precision of this test method as applied to carbon or stainless steels may not be applicable to other materials, which exhibit machineability characteristics that differ considerably from those of steel and even from each other. The high-speed hole drilling technique has been reported as being effective with such diverse materials as copper, aluminum, zirconium and stellite (7).

12. Keywords

12.1 hole-drilling; residual stress measurement; strain gages; stress analysis

REFERENCES

- (1) Perry, C. G. "Data-Reduction Algorithms for Strain-Gage Rosette Measurements," *Experimental Techniques*, Vol 12, No. 5, 1989, pp. 13–18.
- (2) Schajer, G. S., "Application of Finite Element Calculations to Residual Stress Measurements," *Journal of Engineering Materials and Technology, Transactions, ASME*, Vol 103, April 1981, pp. 157–163.
- (3) Rendler, N. J., and Vigness, I., "Hole-Drilling Strain Gage Method of Measuring Residual Stresses," *Experimental Mechanics*, Vol 6, No. 12, 1966, pp. 577–586.
- (4) Perry, C. C., and Lissner, H. R., *Strain Gage Primer*, McGraw-Hill Book Co., Inc., New York, NY, 1955
- (5) Bush, A. J., and Kromer, F. J., "Simplification of the Hole-Drilling Method of Residual Stress Measurements," *ISA Transaction*, Vol 112, No. 3, 1973, pp. 249–260.
- (6) Beaney, E. M., "Accurate Measurements of Residual Stress on Any Steel Using the Centre Hole Method," *Strain, Journal BSSM*, Vol 12, No. 3, 1976, pp. 99–106.
- (7) Flaman, M. T., and Herring, J. A., "Comparison of Four Hole-Producing Techniques for the Center-Hole Residual-Stress Measurement Method," *Experimental Techniques*, Vol 9, No. 8, 1985, pp. 30–32.
- (8) Flaman, M. T., "Investigation of Ultra-High Speed Drilling for Residual Stress Measurements by the Center Hole Method," *Experimental Mechanics*, Vol 22, No. 1, 1982, pp. 26–30.
- (9) Kelsey, R. A., "Measuring Non-Uniform Residual Stresses by the Hole Drilling Method," *Proceedings, SESA*, Vol 14, No. 1, 1956, pp. 181–194.
- (10) Sandifer, J. P., and Bowie, G. E., "Residual Stress by Blind Hole Method with Off-Center Hole," *Experimental Mechanics*, Vol 18, No. 5, 1978, pp. 173–179.
- (11) "Measurement of Residual Stresses by the Hole Drilling Strain Gage Method," *Tech Note TN-503-4*, Measurements Group, Raleigh, NC.
- (12) Schajer, G. S. "Judgment of Residual Stress Field Uniformity when Using the Hole-Drilling Method," *Proceedings of the International Conference on Residual Stresses II*, Nancy, France. November 23–25, 1988, pp. 71–77.
- (13) Redner, S., and Perry, C. C., "Factors Affecting the Accuracy of Residual Stress Measurements Using the Blind Hole Drilling Method," *Proceedings of 7th International Conference Experimental Stress Analysis*, August 1982, pp. 604–616.
- (14) Schajer, G. S. "Measurement of Non-Uniform Residual Stresses Using the Hole Drilling Method," *Journal of Engineering Materials and Technology*, Vol 110, No. 4, 1988, Part I: pp. 338–343, Part II: pp. 344–349.
- (15) Beaney, E. M., and Procter, E., "A Critical Evaluation of the Centre Hole Technique for the Measurement of Residual Stresses," *Strain*, Vol 10, No. 1, 1974, pp. 7–14, 52.
- (16) Yavelak, J. J. (compiler), "Bulk-Zero Stress Standard—AISI 1018 Carbon-Steel Specimens, Round Robin Phase 1," *Experimental Techniques*, Vol 9, No. 4, 1985, pp. 38–41.
- (17) Flaman, M. T., and Herring, J. A., "SEM/ASTM Round-Robin

Residual-Stress-Measurement Study—Phase 1, 304 Stainless-Steel Specimen,” *Experimental Techniques*, Vol 10, No. 5, 1986, pp. 23–25.

(18) Weng, C. C., Lin, Y. C., and Chou, C. P., “A Study on the Induced Drilling Stresses in the Centre Hole Method of Residual Stress Measurement,” *Strain*, Vol 28, 1992, pp. 45–51.

(19) Schajer, G. S., and Tootoonian, M., “A New Rosette Design for More

Reliable Hole-Drilling Residual Stress Measurements,” *Experimental Mechanics*, Vol 37, No. 3, 1997, pp. 299–306.

(20) Schajer, G. S., “Strain Data Averaging for the Hole-Drilling Method.” *Experimental Techniques*, Vol 15, No. 2, 1991, pp. 25–28.

(21) Lu, J. (ed.), “Handbook of Measurement of Residual Stresses,” *Society for Experimental Mechanics*, Fairmont Press, Lilburn, GA, 1996, Chapter 2.

The American Society for Testing and Materials takes no position respecting the validity of any patent rights asserted in connection with any item mentioned in this standard. Users of this standard are expressly advised that determination of the validity of any such patent rights, and the risk of infringement of such rights, are entirely their own responsibility.

This standard is subject to revision at any time by the responsible technical committee and must be reviewed every five years and if not revised, either reapproved or withdrawn. Your comments are invited either for revision of this standard or for additional standards and should be addressed to ASTM Headquarters. Your comments will receive careful consideration at a meeting of the responsible technical committee, which you may attend. If you feel that your comments have not received a fair hearing you should make your views known to the ASTM Committee on Standards, at the address shown below.

This standard is copyrighted by ASTM, 100 Barr Harbor Drive, PO Box C700, West Conshohocken, PA 19428-2959, United States. Individual reprints (single or multiple copies) of this standard may be obtained by contacting ASTM at the above address or at 610-832-9585 (phone), 610-832-9555 (fax), or service@astm.org (e-mail); or through the ASTM website (www.astm.org).