



Designation: E 92 – 82 (Reapproved 1997)<sup>ε3</sup>

## Standard Test Method for Vickers Hardness of Metallic Materials<sup>1</sup>

This standard is issued under the fixed designation E 92; the number immediately following the designation indicates the year of original adoption or, in the case of revision, the year of last revision. A number in parentheses indicates the year of last reapproval. A superscript epsilon (ε) indicates an editorial change since the last revision or reapproval.

*This standard has been approved for use by agencies of the Department of Defense.*

<sup>ε1</sup> NOTE—Section 27 was added editorially in October 1997.

<sup>ε2</sup> NOTE—The term *load* was changed to *force* editorially throughout in May 1999.

<sup>ε3</sup> NOTE—Table 4, Table 5 and Table 6 were editorially revised in April 2000.

### 1. Scope

1.1 This test method covers the determination of the Vickers hardness of metallic materials, using applied forces of 1 kgf to 120 kgf,<sup>2</sup> the verification of Vickers hardness testing machines (Part B), and the calibration of standardized hardness test blocks (Part C). Two general classes of standard tests are recognized:

1.1.1 *Verification, Laboratory, or Referee Tests*, where a high degree of accuracy is required.

1.1.2 *Routine Tests*, where a somewhat lower degree of accuracy is permissible.

1.2 *This standard does not purport to address all of the safety concerns, if any, associated with its use. It is the responsibility of the user of this standard to establish appropriate safety and health practices and determine the applicability of regulatory limitations prior to use.*

### 2. Referenced Documents

#### 2.1 ASTM Standards:

E 4 Practices for Force Verification of Testing Machines<sup>3</sup>

<sup>1</sup> This test method is under the jurisdiction of ASTM Committee E28 on Mechanical Testing and is the direct responsibility of Subcommittee E28.06 on Indentation Hardness Testing.

Current edition approved July 30, 1982. Published December 1982. Originally published as E 92 – 52 T. Last previous edition E 92 – 72 (1977).

<sup>2</sup> A procedure covering Vickers tests using applied forces of 1 gf to 1000 gf (1 kgf) may be found in Test Method E 384, Test Method for Microhardness of Materials, appearing in the *Annual Book of ASTM Standards*, Vol 03.01.

<sup>3</sup> *Annual Book of ASTM Standards*, Vol 03.01.

E 140 Hardness Conversion Tables for Metals (Relationship Between Brinell Hardness, Vickers Hardness, Rockwell Hardness, Rockwell Superficial Hardness, Knoop Hardness, and Scleroscope Hardness)<sup>3</sup>

E 384 Test Method for Microhardness of Materials<sup>3</sup>

### 3. Terminology

3.1 *Vickers hardness number, HV*—a number related to the applied force and the surface area of the permanent impression made by a square-based pyramidal diamond indenter having included face angles of 136° (see Fig. 1 and Table 1), computed from the equation:

$$HV = 2P \sin(\alpha/2)/d^2 = 1.8544P/d^2 \quad (1)$$

where:

$P$  = force, kgf,

$d$  = mean diagonal of impression, mm, and

$\alpha$  = face angle of diamond = 136°.

3.2 *Vickers hardness test*—an indentation hardness test using calibrated machines to force a square-based pyramidal diamond indenter having specified face angles, under a predetermined force, into the surface of the material under test and to measure the diagonals of the resulting impression after removal of the force.

3.2.1 Vickers hardness tests are made at test forces of 1 kgf to 120 kgf.

3.2.2 For practical purposes the Vickers hardness number is constant when a square-based diamond pyramid with a face angle of 136° is used with applied forces of 5 kgf and higher.

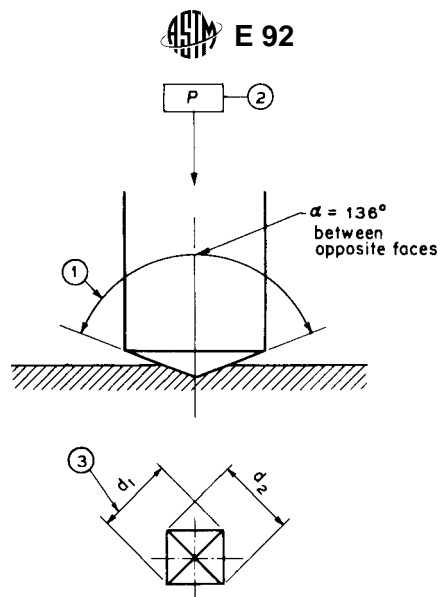

**FIG. 1 Vickers Hardness Test (see Table 1)**

**TABLE 1 Symbols and Designations Associated with Fig. 1**

| Number | Symbol   | Designation  |
|--------|----------|--|
| 1      | ...      | Angle at the vertex of the pyramidal indenter (136°)                                 |
| 2      | <i>P</i> | Test force in kilograms-force  |
| 3      | <i>d</i> | Arithmetic mean of the two diagonals <i>d</i> <sup>1</sup> and <i>d</i> <sup>2</sup> |

**TABLE 2 Vickers Hardness Numbers  
(Diamond, 136° Face Angle, force of 1 kgf)**

| Diagonal of Impression, mm | Vickers Hardness Number for Diagonal Measured to 0.0001 mm |        |        |        |        |        |        |        |        |        |
|----------------------------|--|--------|--------|--------|--------|--------|--------|--------|--------|--------|
|                            | 0.0000   | 0.0001 | 0.0002 | 0.0003 | 0.0004 | 0.0005 | 0.0006 | 0.0007 | 0.0008 | 0.0009 |
| 0.005                      | 74 170   | 71 290 | 68 580 | 66 020 | 63 590 | 61 300 | 59 130 | 57 080 | 55 120 | 53 270 |
| 0.006                      | 51 510   | 49 840 | 48 240 | 46 720 | 45 270 | 43 890 | 42 570 | 41 310 | 40 100 | 38 950 |
| 0.007                      | 37 840   | 36 790 | 35 770 | 34 800 | 33 860 | 32 970 | 32 100 | 31 280 | 30 480 | 29 710 |
| 0.008                      | 28 970   | 28 260 | 27 580 | 26 920 | 26 280 | 25 670 | 25 070 | 24 500 | 23 950 | 23 410 |
| 0.009                      | 22 890   | 22 390 | 21 910 | 21 440 | 20 990 | 20 550 | 20 120 | 19 710 | 19 310 | 18 920 |
| 0.010                      | 18 540   | 18 180 | 17 820 | 17 480 | 17 140 | 16 820 | 16 500 | 16 200 | 15 900 | 15 610 |
| 0.011                      | 15 330   | 15 050 | 14 780 | 14 520 | 14 270 | 14 020 | 13 780 | 13 550 | 13 320 | 13 090 |
| 0.012                      | 12 880   | 12 670 | 12 460 | 12 260 | 12 060 | 11 870 | 11 680 | 11 500 | 11 320 | 11 140 |
| 0.013                      | 10 970   | 10 810 | 10 640 | 10 480 | 10 330 | 10 170 | 10 030 | 9 880  | 9 737  | 9 598  |
| 0.014                      | 9 461  | 9 327  | 9 196  | 9 068  | 8 943  | 8 820  | 8 699  | 8 581  | 8 466  | 8 353  |
| 0.015                      | 8 242  | 8 133  | 8 026  | 7 922  | 7 819  | 7 718  | 7 620  | 7 523  | 7 428  | 7 335  |
| 0.016                      | 7 244  | 7 154  | 7 066  | 6 979  | 6 895  | 6 811  | 6 729  | 6 649  | 6 570  | 6 493  |
| 0.017                      | 6 416  | 6 342  | 6 268  | 6 196  | 6 125  | 6 055  | 5 986  | 5 919  | 5 853  | 5 787  |
| 0.018                      | 5 723  | 5 660  | 5 598  | 5 537  | 5 477  | 5 418  | 5 360  | 5 303  | 5 247  | 5 191  |
| 0.019                      | 5 137  | 5 083  | 5 030  | 4 978  | 4 927  | 4 877  | 4 827  | 4 778  | 4 730  | 4 683  |
| 0.020                      | 4 636  | 4 590  | 4 545  | 4 500  | 4 456  | 4 413  | 4 370  | 4 328  | 4 286  | 4 245  |
| 0.021                      | 4 205  | 4 165  | 4 126  | 4 087  | 4 049  | 4 012  | 3 975  | 3 938  | 3 902  | 3 866  |
| 0.022                      | 3 831  | 3 797  | 3 763  | 3 729  | 3 696  | 3 663  | 3 631  | 3 599  | 3 567  | 3 536  |
| 0.023                      | 3 505  | 3 475  | 3 445  | 3 416  | 3 387  | 3 358  | 3 329  | 3 301  | 3 274  | 3 246  |
| 0.024                      | 3 219  | 3 193  | 3 166  | 3 140  | 3 115  | 3 089  | 3 064  | 3 039  | 3 015  | 2 991  |
| 0.025                      | 2 967  | 2 943  | 2 920  | 2 897  | 2 874  | 2 852  | 2 830  | 2 808  | 2 786  | 2 764  |
| 0.026                      | 2 743  | 2 722  | 2 701  | 2 681  | 2 661  | 2 641  | 2 621  | 2 601  | 2 582  | 2 563  |
| 0.027                      | 2 544  | 2 525  | 2 506  | 2 488  | 2 470  | 2 452  | 2 434  | 2 417  | 2 399  | 2 382  |
| 0.028                      | 2 365  | 2 348  | 2 332  | 2 315  | 2 299  | 2 283  | 2 267  | 2 251  | 2 236  | 2 220  |
| 0.029                      | 2 205  | 2 190  | 2 175  | 2 160  | 2 145  | 2 131  | 2 116  | 2 102  | 2 088  | 2 074  |
| 0.030                      | 2 060  | 2 047  | 2 033  | 2 020  | 2 007  | 1 993  | 1 980  | 1 968  | 1 955  | 1 942  |
| 0.031                      | 1 930  | 1 917  | 1 905  | 1 893  | 1 881  | 1 869  | 1 857  | 1 845  | 1 834  | 1 822  |
| 0.032                      | 1 811  | 1 800  | 1 788  | 1 777  | 1 766  | 1 756  | 1 745  | 1 734  | 1 724  | 1 713  |
| 0.033                      | 1 703  | 1 693  | 1 682  | 1 672  | 1 662  | 1 652  | 1 643  | 1 633  | 1 623  | 1 614  |



**TABLE 2** *Continued*

| Diagonal of Impression, mm | Vickers Hardness Number for Diagonal Measured to 0.0001 mm |        |        |        |        |        |        |        |        |        |
|----------------------------|--|--------|--------|--------|--------|--------|--------|--------|--------|--------|
|                            | 0.0000   | 0.0001 | 0.0002 | 0.0003 | 0.0004 | 0.0005 | 0.0006 | 0.0007 | 0.0008 | 0.0009 |
| 0.034                      | 1 604  | 1 595  | 1 585  | 1 576  | 1 567  | 1 558  | 1 549  | 1 540  | 1 531  | 1 522  |
| 0.035                      | 1 514  | 1 505  | 1 497  | 1 488  | 1 480  | 1 471  | 1 463  | 1 455  | 1 447  | 1 439  |
| 0.036                      | 1 431  | 1 423  | 1 415  | 1 407  | 1 400  | 1 392  | 1 384  | 1 377  | 1 369  | 1 362  |
| 0.037                      | 1 355  | 1 347  | 1 340  | 1 333  | 1 326  | 1 319  | 1 312  | 1 305  | 1 298  | 1 291  |
| 0.038                      | 1 284  | 1 277  | 1 271  | 1 264  | 1 258  | 1 251  | 1 245  | 1 238  | 1 232  | 1 225  |
| 0.039                      | 1 219  | 1 213  | 1 207  | 1 201  | 1 195  | 1 189  | 1 183  | 1 177  | 1 171  | 1 165  |
| 0.040                      | 1 159  | 1 153  | 1 147  | 1 142  | 1 136  | 1 131  | 1 125  | 1 119  | 1 114  | 1 109  |
| 0.041                      | 1 103  | 1 098  | 1 092  | 1 087  | 1 082  | 1 077  | 1 072  | 1 066  | 1 061  | 1 056  |
| 0.042                      | 1 051  | 1 046  | 1 041  | 1 036  | 1 031  | 1 027  | 1 022  | 1 017  | 1 012  | 1 008  |
| 0.043                      | 1 003  | 998    | 994    | 989    | 985    | 980    | 975    | 971    | 967    | 962    |
| 0.044                      | 958  | 953    | 949    | 945    | 941    | 936    | 932    | 928    | 924    | 920    |
| 0.045                      | 916  | 912    | 908    | 904    | 900    | 896    | 892    | 888    | 884    | 880    |
| 0.046                      | 876  | 873    | 869    | 865    | 861    | 858    | 854    | 850    | 847    | 843    |
| 0.047                      | 839  | 836    | 832    | 829    | 825    | 822    | 818    | 815    | 812    | 808    |
| 0.048                      | 805  | 802    | 798    | 795    | 792    | 788    | 785    | 782    | 779    | 775    |
| 0.049                      | 772  | 769    | 766    | 763    | 760    | 757    | 754    | 751    | 748    | 745    |
| 0.050                      | 742  | 739    | 736    | 733    | 730    | 727    | 724    | 721    | 719    | 716    |
| 0.051                      | 713  | 710    | 707    | 705    | 702    | 699    | 696    | 694    | 691    | 688    |
| 0.052                      | 686  | 683    | 681    | 678    | 675    | 673    | 670    | 668    | 665    | 663    |
| 0.053                      | 660  | 658    | 655    | 653    | 650    | 648    | 645    | 643    | 641    | 638    |
| 0.054                      | 636  | 634    | 631    | 629    | 627    | 624    | 622    | 620    | 617    | 615    |
| 0.055                      | 613  | 611    | 609    | 606    | 604    | 602    | 600    | 598    | 596    | 593    |
| 0.056                      | 591  | 589    | 587    | 585    | 583    | 581    | 579    | 577    | 575    | 573    |
| 0.057                      | 571  | 569    | 567    | 565    | 563    | 561    | 559    | 557    | 555    | 553    |
| 0.058                      | 551  | 549    | 547    | 546    | 544    | 542    | 540    | 538    | 536    | 535    |
| 0.059                      | 533  | 531    | 529    | 527    | 526    | 524    | 522    | 520    | 519    | 516.8  |
| 0.060                      | 515.1  | 513.4  | 511.7  | 510.0  | 508.3  | 506.6  | 505.0  | 503.3  | 501.6  | 500.0  |
| 0.061                      | 498.4  | 496.7  | 495.1  | 493.5  | 491.9  | 490.3  | 488.7  | 487.1  | 485.5  | 484.0  |
| 0.062                      | 482.4  | 480.9  | 479.3  | 477.8  | 476.2  | 474.7  | 473.2  | 471.7  | 470.2  | 468.7  |
| 0.063                      | 467.2  | 465.7  | 464.3  | 462.8  | 461.3  | 459.9  | 458.4  | 457.0  | 455.6  | 454.1  |
| 0.064                      | 452.7  | 451.3  | 449.9  | 448.5  | 447.1  | 445.7  | 444.4  | 443.0  | 441.6  | 440.3  |
| 0.065                      | 438.9  | 437.6  | 436.2  | 434.9  | 433.6  | 432.2  | 430.9  | 429.6  | 428.3  | 427.0  |
| 0.066                      | 425.7  | 424.4  | 423.1  | 421.9  | 420.6  | 419.3  | 418.1  | 416.8  | 415.6  | 414.3  |
| 0.067                      | 413.1  | 411.9  | 410.6  | 409.4  | 408.2  | 407.0  | 405.8  | 404.6  | 403.4  | 402.2  |
| 0.068                      | 401.0  | 399.9  | 398.7  | 397.5  | 396.6  | 395.2  | 394.0  | 392.9  | 391.8  | 390.6  |
| 0.069                      | 389.5  | 388.4  | 387.2  | 386.1  | 385.0  | 383.9  | 382.8  | 381.7  | 380.6  | 379.5  |
| 0.070                      | 378.4  | 377.4  | 376.3  | 375.2  | 374.2  | 373.1  | 372.0  | 371.0  | 369.9  | 368.9  |
| 0.071                      | 367.9  | 366.8  | 365.8  | 364.8  | 363.7  | 362.7  | 361.7  | 360.7  | 359.7  | 358.7  |
| 0.072                      | 357.7  | 356.7  | 355.7  | 354.7  | 353.8  | 352.8  | 351.8  | 350.9  | 349.9  | 348.9  |
| 0.073                      | 348.0  | 347.0  | 346.1  | 345.1  | 344.2  | 343.3  | 342.3  | 341.4  | 340.5  | 339.6  |
| 0.074                      | 338.6  | 337.7  | 336.8  | 335.9  | 335.0  | 334.1  | 333.2  | 332.3  | 331.4  | 330.5  |
| 0.075                      | 329.7  | 328.8  | 327.9  | 327.0  | 326.2  | 325.3  | 324.5  | 323.6  | 322.7  | 321.9  |
| 0.076                      | 321.0  | 320.2  | 319.4  | 318.5  | 317.7  | 316.9  | 316.0  | 315.2  | 314.4  | 313.6  |
| 0.077                      | 312.8  | 312.0  | 311.1  | 310.3  | 309.5  | 308.7  | 307.9  | 307.2  | 306.4  | 305.6  |
| 0.078                      | 304.8  | 304.0  | 303.2  | 302.5  | 301.7  | 300.9  | 300.2  | 299.4  | 298.6  | 297.9  |
| 0.079                      | 297.1  | 296.4  | 295.6  | 294.9  | 294.1  | 293.4  | 292.7  | 291.9  | 291.2  | 290.5  |
| 0.080                      | 289.7  | 289.0  | 288.3  | 287.6  | 286.9  | 286.2  | 285.4  | 284.7  | 284.0  | 283.3  |
| 0.081                      | 282.6  | 281.9  | 281.2  | 280.6  | 279.9  | 279.2  | 278.5  | 277.8  | 277.1  | 276.5  |
| 0.082                      | 275.8  | 275.1  | 274.4  | 273.8  | 273.1  | 272.4  | 271.8  | 271.1  | 270.5  | 269.8  |
| 0.083                      | 269.2  | 268.5  | 267.9  | 267.2  | 266.6  | 266.0  | 265.3  | 264.7  | 264.1  | 263.4  |
| 0.084                      | 262.8  | 262.2  | 261.6  | 260.9  | 260.3  | 259.7  | 259.1  | 258.5  | 257.9  | 257.3  |
| 0.085                      | 256.7  | 256.1  | 255.5  | 254.9  | 254.3  | 253.7  | 253.1  | 252.5  | 251.9  | 251.3  |
| 0.086                      | 250.7  | 250.1  | 249.6  | 249.0  | 248.4  | 247.8  | 247.3  | 246.7  | 246.1  | 245.6  |
| 0.087                      | 245.0  | 244.4  | 243.9  | 243.3  | 242.8  | 242.2  | 241.6  | 241.1  | 240.6  | 240.0  |
| 0.088                      | 239.5  | 238.9  | 238.4  | 237.8  | 237.3  | 236.8  | 236.2  | 235.7  | 235.2  | 234.6  |
| 0.089                      | 234.1  | 233.6  | 233.1  | 232.5  | 232.0  | 231.5  | 231.0  | 230.5  | 230.0  | 229.4  |
| 0.090                      | 228.9  | 228.4  | 227.9  | 227.4  | 226.9  | 226.4  | 225.9  | 225.4  | 224.9  | 224.4  |
| 0.091                      | 223.9  | 223.4  | 222.9  | 222.5  | 222.0  | 221.5  | 221.0  | 220.5  | 220.0  | 219.6  |
| 0.092                      | 219.1  | 218.6  | 218.1  | 217.7  | 217.1  | 216.7  | 216.3  | 215.8  | 215.3  | 214.9  |
| 0.093                      | 214.4  | 213.9  | 213.5  | 213.0  | 212.6  | 212.1  | 211.7  | 211.2  | 210.8  | 210.3  |



**TABLE 2** *Continued*

| Diagonal of Impression, mm | Vickers Hardness Number for Diagonal Measured to 0.0001 mm |        |        |        |        |        |        |        |        |        |
|----------------------------|--|--------|--------|--------|--------|--------|--------|--------|--------|--------|
|                            | 0.0000   | 0.0001 | 0.0002 | 0.0003 | 0.0004 | 0.0005 | 0.0006 | 0.0007 | 0.0008 | 0.0009 |
| 0.094                      | 209.9  | 209.4  | 209.0  | 208.5  | 208.1  | 207.6  | 207.2  | 206.8  | 206.3  | 205.9  |
| 0.095                      | 205.5  | 205.0  | 204.6  | 204.2  | 203.8  | 203.3  | 202.9  | 202.5  | 202.1  | 201.6  |
| 0.096                      | 201.2  | 200.8  | 200.4  | 200.0  | 199.5  | 199.1  | 198.7  | 198.3  | 197.9  | 197.5  |
| 0.097                      | 197.1  | 196.7  | 196.3  | 195.9  | 195.5  | 195.1  | 194.7  | 194.3  | 193.9  | 193.5  |
| 0.098                      | 193.1  | 192.7  | 192.3  | 191.9  | 191.5  | 191.1  | 190.7  | 190.4  | 190.0  | 189.6  |
| 0.099                      | 189.2  | 188.8  | 188.4  | 188.1  | 187.7  | 187.3  | 186.9  | 186.6  | 186.2  | 185.5  |

At lower test forces the Vickers hardness may be force-dependent. In Table 2 are given the Vickers hardness numbers for a test force of 1 kgf. For obtaining hardness numbers when other test forces are used, the Vickers hardness number obtained from Table 2 is multiplied by the test force in kilograms-force (Table 3).

NOTE 1—The Vickers hardness number is followed by the symbol HV with a suffix number denoting the force and second suffix number

**TABLE 3** **Decimal Point Finder for Use with Table 2**

An example of determination of hardness numbers follows the table.

| Diagonal Length, mm | Vickers Hardness (HV), 1-kgf Force |
|---------------------|------------------------------------|
| 0.005               | 74 200                             |
| 0.006               | 51 500                             |
| 0.007               | 37 800                             |
| 0.008               | 29 000                             |
| 0.009               | 22 900                             |
| 0.010               | 18 540                             |
| 0.020               | 4 640                              |
| 0.030               | 2 060                              |
| 0.040               | 1 159                              |
| 0.050               | 742                                |
| 0.060               | 515                                |
| 0.070               | 378                                |
| 0.080               | 290                                |
| 0.090               | 229                                |
| 0.100               | 185.4                              |
| 0.200               | 46.4                               |
| 0.300               | 20.6                               |
| 0.400               | 11.6                               |
| 0.500               | 7.42                               |
| 0.600               | 5.15                               |
| 0.700               | 3.78                               |
| 0.800               | 2.90                               |
| 0.900               | 2.29                               |
| 1.000               | 1.85                               |
| 1.100               | 1.53                               |
| 1.200               | 1.29                               |
| 1.300               | 0.10                               |
| 1.400               | 0.946                              |
| 1.500               | 0.824                              |
| 1.600               | 0.724                              |
| 1.700               | 0.642                              |
| 1.800               | 0.572                              |
| 1.900               | 0.514                              |
| 2.000               | 0.464                              |

*Example*—Using a 50-kgf test force, the average measured diagonal length = 0.644 mm.

In Table 2 read:

$$HV = 447 \text{ at } 0.0644\text{-mm diagonal length at } 1\text{-kgf force.}$$

Using Table 3 determine:

$$HV = 4.47 \text{ at } 0.644\text{-mm diagonal length at } 1\text{-kgf force.}$$

$$50 \times 4.47 = 224 \text{ HV for } 50\text{-kg test force.}$$

indicating the duration of forcing when the latter differs from 10 to 15 s, which is the normal force time. *Example:*

440 HV 30 = Vickers hardness of 440 measured under a force of 30 kgf applied for 10 to 15 s.

440 HV 30/20 = Vickers hardness of 440 measured under a force of 30 kgf applied for 20 s.

3.3 *verification*—checking or testing to assure conformance with the specification.

3.4 *calibration*—determination of the values of the significant parameters by comparison with values indicated by a reference instrument or by a set of reference standards.

## A. GENERAL DESCRIPTION AND TEST PROCEDURE FOR VICKERS HARDNESS TESTS

### 4. Apparatus

4.1 *Testing Machine*—Equipment for Vickers hardness testing usually consists of a testing machine which supports the specimen and permits the indenter and the specimen to be brought into contact gradually and smoothly under a predetermined force, which is applied for a fixed period of time. The design of the machine should be such that no rocking or lateral movement of the indenter or specimen is permitted while the force is being applied or removed. A measuring microscope is usually mounted on the machine in such a manner that the impression in the specimen may be readily located in the optical field.

#### 4.2 Indenter:

4.2.1 The indenter shall be a highly polished, pointed, square-based pyramidal diamond with face angles of  $136^\circ \pm 30 \text{ min}$ .

4.2.2 All four faces of the indenter shall be equally inclined to the axis of the indenter (within  $\pm 30 \text{ min}$ ) and meet at a sharp point, that is, the line of junction between opposite faces shall not be more than 0.001 mm in length as shown in Fig. 2.

4.2.3 The diamond should be examined periodically and if it is loose in the mounting material, chipped, or cracked, it should be discarded or reconditioned.

NOTE 2—The condition of the point of the indenter is of considerable importance where the test force is light and the impression is small. It is recommended that the point be periodically checked by examining an impression made in a polished steel block. Under a magnification of  $600\times$  or more, using a vertical illuminator, any chipping or rounding of the point can be detected and the extent of the defect measured with a filar micrometer. It is recommended that a diamond pyramid indenter should not be used for tests in which the maximum length of such a defect exceeds 5% of the length of the impression diagonal.

4.3 *Measuring Microscope*—The divisions of the micrometer scale of the measuring microscope or other measuring

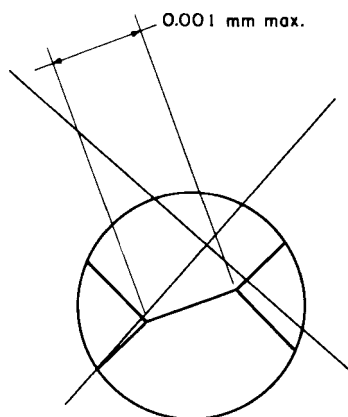

**FIG. 2 Junction of Indenter Faces**

device shall be so constructed that the length of the diagonals of an impression in a properly surface-finished specimen (see section 5.1.2) can be measured to within  $\pm 0.0005$  mm or  $\pm 0.5\%$ , whichever is larger.

### 5. Test Specimen

5.1 The Vickers hardness test is adaptable to a wide variety of test specimens ranging from large bars and rolled sections to minute pieces in metallographic mounts. In general the backs of the specimens shall be so finished or the specimens shall be so clamped that there is no possibility of their rocking or shifting under the test force. The specimens shall also conform to the requirements given in the following 5.1.1, 5.1.2, and 5.1.3.

5.1.1 *Thickness*—The thickness of the test specimen shall be such that no bulge or marking showing the effect of the force appears on the side of the specimen opposite the impression. In any event the thickness of the specimen shall be at least one and one half times the length of the diagonal. When laminated material is tested, the thickness of the individual component being tested shall be used for the thickness-diagonal length relationship.

5.1.2 *Finish*—The surface of the specimen should be so prepared that the ends of the diagonals are clearly defined and can be read with precision of  $\pm 0.0005$  mm or  $\pm 0.5\%$  of the length of the diagonals, whichever is larger. Care should be taken in specimen preparation to avoid tempering during grinding, or work-hardening the surface during polishing.

5.1.3 *Alignment*—The specimen should be so prepared or mounted that the surface is normal to the axis of the indenter within  $\pm 1^\circ$  of angle. This can readily be accomplished by surface grinding (or otherwise machining) the opposite side of the specimen to parallelism with the side to be tested.

5.1.4 *Radius of Curvature*—Until further investigative work is accomplished to determine the effect of the radius of curvature on readings, due caution should be used in interpreting or accepting the results of tests made on cylindrical surfaces.

NOTE 3—A method recommended by the International Organization for Standardization for correcting Vickers hardness readings taken on spherical or cylindrical surfaces is given in Table 4, Table 5, and Table 6.

NOTE 4—These tables give correction factors to be applied to Vickers hardness values obtained when tests are made on spherical or cylindrical

**TABLE 4 Correction Factors for Use in Vickers Hardness Tests Made on Spherical Surfaces**

| Convex Surface |                   | Concave Surface |                   |
|----------------|-------------------|-----------------|-------------------|
| $d/D^A$        | Correction Factor | $d/D^A$         | Correction Factor |
| 0.004          | 0.995             | 0.004           | 1.005             |
| 0.009          | 0.990             | 0.008           | 1.010             |
| 0.013          | 0.985             | 0.012           | 1.015             |
| 0.018          | 0.980             | 0.016           | 1.020             |
| 0.023          | 0.975             | 0.020           | 1.025             |
| 0.028          | 0.970             | 0.024           | 1.030             |
| 0.033          | 0.965             | 0.028           | 1.035             |
| 0.038          | 0.960             | 0.031           | 1.040             |
| 0.043          | 0.955             | 0.035           | 1.045             |
| 0.049          | 0.950             | 0.038           | 1.050             |
| 0.055          | 0.945             | 0.041           | 1.055             |
| 0.061          | 0.940             | 0.045           | 1.060             |
| 0.067          | 0.935             | 0.048           | 1.065             |
| 0.073          | 0.930             | 0.051           | 1.070             |
| 0.079          | 0.925             | 0.054           | 1.075             |
| 0.086          | 0.920             | 0.057           | 1.080             |
| 0.093          | 0.915             | 0.060           | 1.085             |
| 0.100          | 0.910             | 0.063           | 1.090             |
| 0.107          | 0.905             | 0.066           | 1.095             |
| 0.114          | 0.900             | 0.069           | 1.100             |
| 0.122          | 0.895             | 0.071           | 1.105             |
| 0.130          | 0.890             | 0.074           | 1.110             |
| 0.139          | 0.885             | 0.077           | 1.115             |
| 0.147          | 0.880             | 0.079           | 1.200             |
| 0.156          | 0.875             | 0.082           | 1.125             |
| 0.165          | 0.870             | 0.084           | 1.130             |
| 0.175          | 0.865             | 0.087           | 1.135             |
| 0.185          | 0.860             | 0.089           | 1.140             |
| 0.195          | 0.855             | 0.091           | 1.145             |
| 0.206          | 0.850             | 0.094           | 1.150             |

<sup>A</sup> $D$  = diameter of sphere.

$d$  = mean diagonal of impression in millimeters.

surfaces. The correction factors are tabulated in terms of the ratio of the mean diagonal  $d$  of the indentation to the diameter  $D$  of the sphere or cylinder. Examples of the use of these tables are:

*Example 1. Convex Sphere:*

Diameter of sphere,  $D$  = 10 mm  
 Load = 10 kgf  
 Mean diagonal of impression,  $d$  = 0.150 mm  
 $d/D = 0.150/10 = 0.015$   
 From Tables 2 and 3, HV = 824  
 From Table 4, by interpolation, correction factor = 0.983  
 Hardness of sphere =  $824 \times 0.983 = 810$  HV 10

*Example 2. Concave Cylinder, One Diagonal Parallel to Axis:*

Diameter of cylinder,  $D$  = 5 mm  
 Load = 30 kgf  
 Mean diagonal of impression,  $d$  = 0.415 mm  
 $d/D = 0.415/5 = 0.083$   
 From Tables 2 and 3, HV = 323  
 From Table 6, correction factor = 1.075  
 Hardness of cylinder =  $323 \times 1.075 = 347$  HV 30.

### 6. Verification of Apparatus

6.1 The hardness testing machine shall be verified as specified in Part B.

6.1.1 Two acceptable methods of verifying Vickers hardness testing machines are given in Part B.



**TABLE 5 Correction Factors for Use in Vickers Hardness Tests Made on Cylindrical Surfaces**  
(Diagonals at 45° to the axis)

| Convex Surface |                   | Concave Surface |                   |
|----------------|-------------------|-----------------|-------------------|
| $d/D^A$        | Correction Factor | $d/D^A$         | Correction Factor |
| 0.009          | 0.995             | 0.009           | 1.005             |
| 0.017          | 0.990             | 0.017           | 1.020             |
| 0.026          | 0.985             | 0.025           | 1.015             |
| 0.035          | 0.980             | 0.034           | 1.020             |
| 0.044          | 0.975             | 0.042           | 1.025             |
| 0.053          | 0.970             | 0.050           | 1.030             |
| 0.062          | 0.965             | 0.058           | 1.035             |
| 0.071          | 0.960             | 0.066           | 1.040             |
| 0.081          | 0.955             | 0.074           | 1.045             |
| 0.090          | 0.950             | 0.082           | 1.050             |
| 0.100          | 0.945             | 0.089           | 1.055             |
| 0.109          | 0.940             | 0.097           | 1.060             |
| 0.119          | 0.935             | 0.104           | 1.065             |
| 0.129          | 0.930             | 0.112           | 1.070             |
| 0.139          | 0.925             | 0.119           | 1.075             |
| 0.149          | 0.920             | 0.127           | 1.080             |
| 0.159          | 0.915             | 0.134           | 1.085             |
| 0.169          | 0.910             | 0.141           | 1.090             |
| 0.179          | 0.905             | 0.148           | 1.095             |
| 0.189          | 0.900             | 0.155           | 1.100             |
| 0.200          | 0.895             | 0.162           | 1.105             |
|                |                   | 0.169           | 1.110             |
|                |                   | 0.176           | 1.115             |
|                |                   | 0.183           | 1.120             |
|                |                   | 0.189           | 1.125             |
|                |                   | 0.196           | 1.130             |
|                |                   | 0.203           | 1.135             |
|                |                   | 0.209           | 1.140             |
|                |                   | 0.216           | 1.140             |
|                |                   | 0.222           | 1.150             |

<sup>A</sup> $D$  = diameter of cylinder.

$d$  = mean diagonal of impression in millimeters.

## 7. Procedure

7.1 *Magnitude of Test Force*—Test forces of 1 kgf to 120 kgf may be used, depending on the requirements of the test. Although tests on homogeneous materials indicate that the Vickers hardness number is nearly independent of the test force, this condition will not be present in cases where there is a hardness gradient from the specimen surface to the interior of the specimen. The magnitude of the test force should therefore be stated in the test report (Section 11).

7.2 *Application of Test Force*—Apply the test force and release smoothly without shock or vibration. The time of application of the full test force shall be 10 to 15 s, unless otherwise specified.

7.3 *Spacing of Indentations*—The center of the impression shall not be closer to any edge of the test specimen or to another impression than a distance equal to two and one half times the length of diagonal of the impression. When laminated material is tested, a bond surface shall be considered as an edge for spacing of indentation calculations.

## 8. Measurement of Impression

8.1 Both diagonals of the impression shall be measured and

**TABLE 6 Correction Factors for Use in Vickers Hardness Tests Made on Cylindrical Surfaces**  
(One diagonal parallel to axis)

| Convex Surface |                   | Concave Surface |                   |
|----------------|-------------------|-----------------|-------------------|
| $d/D^A$        | Correction Factor | $d/D^A$         | Correction Factor |
| 0.009          | 0.995             | 0.048           | 1.035             |
| 0.019          | 0.990             | 0.053           | 1.040             |
| 0.029          | 0.985             | 0.058           | 1.045             |
| 0.041          | 0.980             | 0.063           | 1.050             |
| 0.054          | 0.975             | 0.067           | 1.055             |
| 0.068          | 0.970             | 0.071           | 1.060             |
| 0.085          | 0.965             | 0.076           | 1.065             |
| 0.104          | 0.960             | 0.079           | 1.070             |
| 0.126          | 0.955             | 0.083           | 1.075             |
| 0.153          | 0.950             | 0.087           | 1.080             |
| 0.189          | 0.945             | 0.090           | 1.085             |
| 0.243          | 0.940             | 0.093           | 1.090             |
|                |                   | 0.097           | 1.095             |
|                |                   | 0.100           | 1.100             |
|                |                   | 0.103           | 1.105             |
|                |                   | 0.105           | 1.110             |
|                |                   | 0.108           | 1.115             |
|                |                   | 0.111           | 1.120             |
|                |                   | 0.113           | 1.125             |
|                |                   | 0.116           | 1.130             |
|                |                   | 0.118           | 1.135             |
|                |                   | 0.120           | 1.140             |
|                |                   | 0.123           | 1.145             |
|                |                   | 0.125           | 1.150             |

<sup>A</sup> $D$  = diameter of cylinder.

$d$  = mean diagonal of impression in millimeters.

their mean value used as a basis for calculation of the Vickers hardness number. It is recommended that the measurement be made with the impression centered as nearly as possible in the field of the microscope.

8.2 In the case of anisotropic materials, for example materials that have been heavily cold worked, there may be a difference between the lengths of the two diagonals of the impression. In such cases, the test specimen should be reoriented so that the diagonals of a new impression are approximately of equal length.

## 9. Accuracy

9.1 The accuracy of the Vickers hardness method is a function of the accuracies of the test force, indenter, and measuring device. The condition of the test and support surfaces and support of the test piece during application of the test force also affect accuracy. Under optimum conditions of these factors the accuracy that can be expected is the equivalent of 4% of the Vickers hardness number of the standardized reference hardness test blocks (see section 18.2). Under less than ideal conditions the reduction in accuracy, when required, can be established empirically by employing statistical methods.

## 10. Conversion to Other Hardness Scales or Tensile Strength Values

10.1 There is no general method for converting accurately Vickers hardness numbers to other hardness scales or tensile strength values. Such conversions are, at best, approximations and therefore should be avoided, except for special cases where a reliable basis for the approximate conversions has been obtained by comparison tests.

NOTE 5—Standard E 140 give approximate conversion values for specific materials such as steel, nickel and high-nickel alloys, and cartridge brass.

## 11. Report

- 11.1 The report shall include the following information:
  - 11.1.1 The Vickers hardness number,
  - 11.1.2 The test force used (see 3.2.2, Note 1), and
  - 11.1.3 The force application time, if other than 10 to 15 s (see 3.2.2, Note 1).

## 12. Precision and Bias

12.1 Due to the wide variety of materials tested by this method and the possible variations in test specimens, the precision of this method has not been established. The accepted practice is to utilize the information in 9.1 when establishing hardness tolerances for specific applications. The precision of this method, whether involving a single operator, multiple operators, or multiple laboratories, can be established by employing statistical methods.

## B. VERIFICATION OF VICKERS HARDNESS TESTING MACHINES

### 13. Scope

13.1 Part B covers two procedures for the verification of Vickers hardness testing machines and a procedure that is recommended for use to confirm that the machine has not become maladjusted in the intervals between the periodical routine checks. The two methods of verification are:

13.1.1 Separate verification of force application, indenter, and measuring microscope.

13.1.2 Verification by standardized test block method.

13.2 The first procedure (13.1.1) is mandatory for new and rebuilt machines.

13.3 The second procedure (13.1.2) shall be used for verifying machines in service.

### 14. General Requirements

14.1 Before a Vickers hardness testing machine is verified the machine shall be examined to ensure that:

14.1.1 The machine is properly set up.

14.1.2 The indenter holder is mounted normally in the plunger.

14.1.3 The force can be applied and removed without shock or vibration in such a manner that the readings are not influenced.

14.2 If the measuring device is integral with the machine, the machine shall be examined to ensure that:

14.2.1 The change from forceing to measuring does not influence the readings.

14.2.2 The method of illumination does not affect the readings.

14.2.3 The center of the impression is in the center of the field of view.

### 15. Verification

15.1 *Separate Verification of Force Application, Indenter, and Measuring Microscope:*

15.1.1 *force Application*—The applied force shall be checked by the use of dead weights and proving levers, or by an elastic calibration device or springs in the manner described in Practices E 4. Such dead weights or other forceing devices shall be accurate to  $\pm 0.2\%$ . Vickers hardness testing machines shall be verified at a minimum of three applied forces including the test force specified. A minimum of three readings should be taken at each force. A Vickers hardness testing machine is acceptable for use over a forceing range within which the machine error does not exceed  $\pm 1\%$ .

15.1.2 *Indenter*—The form of the diamond indenter shall be verified by direct measurement of its shape or by measurements of its projection on a screen. The angle between opposite faces of the pyramid shall be  $136^\circ \pm 30$  min. All four faces shall be equally inclined to the axis of the pyramid within  $\pm 30$  min. The four faces of indenters used for laboratory, or routine tests, shall meet at a point no more than 0.001 mm in length (see Fig. 2). The four faces of indenters used in calibrating standardized hardness test blocks, shall meet at a point in which the line of junction between opposite faces is no more than 0.0005 mm in length (see Fig. 3). The quadrilateral that would be formed by the intersection of the four faces with a plane perpendicular to the axis of the indenter shall have angles of  $90^\circ \pm 12$  min.

15.1.3 *Measuring Microscope*—The measuring microscope or other device for measuring the diagonals of the impression shall be calibrated against an accurately ruled line scale (stage micrometer). The errors of the line scale shall not exceed 0.05  $\mu\text{m}$  (0.00005 mm) or 0.05% of any interval, whichever is greater. The measuring microscope shall be calibrated throughout its range of use and a calibration factor chosen such that the error shall not exceed  $\pm 0.5\%$ . It may be necessary to divide the complete range of the micrometer microscope into several subranges, each having its own factor.

15.2 *Verification by Standardized Test Block Method:*

15.2.1 A Vickers hardness testing machine used only for routine testing may be checked by making a series of impressions on standardized hardness test blocks (Part C).

15.2.2 A minimum of five Vickers hardness readings shall be taken on at least three blocks having different levels of hardness using a test force or forces as specified by the user with the test force applied for 12 s.

15.2.3 Vickers hardness testing machines shall be considered verified if the mean diagonal for five hardness impressions meets the requirements of 17.2.

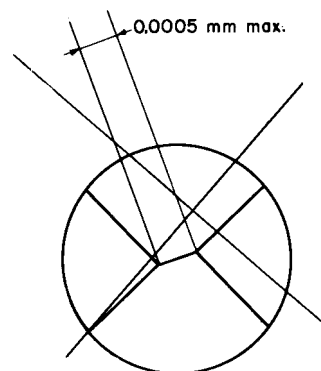

**FIG. 3 Junction of Indenter Faces**

## 16. Procedure for Periodic Checks by the User

16.1 Verification by the standardized test block method (15.2.2) is too lengthy for daily use. Instead the following is recommended:

16.1.1 Make at least one routine check each day that the testing machine is used.

16.1.2 Before making the check, verify that the zero reading of the measuring apparatus is correctly adjusted.

16.1.3 Make at least five hardness readings on a standardized hardness test block on the scale and at the hardness level at which the machine is being used. If the values fall within the range of the standardized hardness test block the machine may be regarded as satisfactory; if not the machine should be verified as described in 15.2.2.

## 17. Repeatability and Error

### 17.1 Repeatability:

17.1.1 For each standardized block, let  $d_1, d_2, \dots, d_5$  be the arithmetic means of the two diagonals of the indentations, arranged in increasing order of magnitude.

17.1.2 The repeatability of the machine under the particular verification conditions is expressed by the quantity  $d_5 - d_1$ .

### 17.2 Error:

17.2.1 The error of the machine under the particular verification conditions is expressed by the quantity  $\bar{d} - d$ , where  $\bar{d} = (d_1 + d_2 + \dots + d_5)/5$ , and  $d$  is the reported mean diagonal of impressions on the standardized hardness test block.

## 18. Assessment of Verification

18.1 *Repeatability*—The repeatability of the machine verified is considered satisfactory if it satisfies the conditions given in Table 7.

18.2 *Error*—The mean diagonal for five impressions should not differ from the mean diagonal corresponding to the Vickers hardness of the standardized test block by more than 2% or 0.5  $\mu\text{m}$  (0.0005 mm), whichever is greater.

## C. CALIBRATION OF STANDARD HARDNESS TEST BLOCKS FOR VICKERS HARDNESS MACHINES

### 19. Scope

19.1 Part C covers the calibration of standardized hardness test blocks for the verification of Vickers hardness testing machines as described in Part B.

### 20. Manufacture

20.1 Each metal block to be standardized shall be not less than 1/4 in. (6 mm) in thickness.

20.2 Each block shall be specially prepared and heat treated to give the necessary homogeneity and stability of structure.

20.3 Each block, if of steel, shall be demagnetized by the manufacturer and maintained demagnetized by the user.

20.4 The lower surface of the test block shall have a fine ground finish.

20.5 The test (upper) surface shall be polished and free of scratches which would interfere with measurements of the diagonals of the impression.

20.5.1 The mean surface roughness height rating shall not exceed 4  $\mu\text{in.}$  (0.0001 mm) center line average.

20.6 To ensure that no material is subsequently removed from the test surface of the standardized test block, an official mark or the thickness at the time of calibration shall be marked on the test surface to an accuracy of  $\pm 0.005$  in. ( $\pm 0.1$  mm).

## 21. Standardizing Procedure

21.1 The standardized hardness test blocks shall be calibrated on a Vickers hardness testing machine verified in accordance with the requirements of 13.1.1.

21.2 The mechanism that controls the application of force should either:

21.2.1 Employ a device such as a spring to reduce the velocity of indentation of the indenter during the period of indentation, or

21.2.2 Employ a device to maintain a constant velocity of indentation of the indenter.

21.3 The full test force shall be applied for 12 s.

## 22. Number of Indentations

22.1 At least five and preferably ten randomly distributed indentations shall be made on each test block.

## 23. Measurement of the Diagonals of the Indentation

23.1 The illuminating system of the measuring microscope shall be adjusted to give uniform intensity over the field of view and maximum contrast between the indentation and the undistributed surface of the block.

23.2 The measuring microscope shall be graduated to read 0.001 mm with estimates made to the nearest  $\pm 0.0002$  mm.

23.3 The measuring microscope shall be checked by a stage micrometer, or by other suitable means, to ensure that the difference between readings corresponding to any two divisions of the instrument is correct within  $\pm 0.0005$  mm.

23.4 It is recommended that each indentation be measured by two observers.

## 24. Repeatability

24.1 Let  $d_1, d_2, \dots, d_n$  be the mean values of the measured diagonals as determined by one observer, arranged in increasing order of magnitude.

24.2 The repeatability of the hardness readings on the block is defined as  $(d_{10} - d_1)$ , when ten readings have been made or  $1.32(d_5 - d_1)$  when five readings are taken on the block.

## 25. Uniformity of Hardness

25.1 Unless the repeatability of hardness readings as measured by the mean diagonals of five or ten impressions is within the limits given in Table 8, the block cannot be regarded as sufficiently uniform for standardization purposes.

**TABLE 7 Repeatability of Machines**

| Range of Standardized Hardness of Test Blocks | The Repeatability of the Machine Should be Less Than: | Examples of Equivalents in Hardness Units |
|---|---|---|
| 100 to 240, incl                              | 4 % of $d^{A,B}$                                      | 8 at 100 HV; 16 at 200 HV                 |
| Over 240 to 600, incl                         | 3 % of $d^{A,B}$                                      | 18 at 300 HV; 36 at 600 HV                |
| Over 600                                      | 2 % of $d^{A,B}$                                      | 28 at 700 HV                              |

<sup>A</sup> $d = (d_1 + d_2 + \dots + d_5)/5$ .

<sup>B</sup>In all cases the repeatability is the percentage given or 1  $\mu\text{m}$  (0.001 mm), whichever is the greater.





**TABLE 8 Repeatability of Hardness Readings**

| Range of Standardized Hardness of Test Block | The Repeatability of the Test Block Readings Shall be Less Than: |
|--|--|
| 100 to 240, incl                             | 3 % of $d^{A,B}$   |
| Over 240 to 600, incl                        | 2 % of $d^{A,B}$   |
| Over 600                                     | 1.5 % of $d^{A,B}$   |

<sup>A</sup> $d = (d_1 + d_2 + \dots + d_n)/n$ .

<sup>B</sup>In all cases the repeatability is the percentage given or 1  $\mu\text{m}$  (0.001 mm), whichever is the greater.

## 26. Marking

26.1 Each block shall be marked with the following:

26.1.1 Arithmetic mean of the hardness values found in the

standardization test (see also 3.2.2, Note 1).

26.1.2 The name or mark of the supplier,

26.1.3 The serial number of the block, and

26.1.4 The thickness of the test block or an official mark on the top surface (see section 19.6).

NOTE 6—All of the markings except the official mark or thickness should be placed on the side of the block, the markings being upright when the test surface is the upper face.

## 27. Keywords

27.1 metallic; Vickers hardness

*ASTM International takes no position respecting the validity of any patent rights asserted in connection with any item mentioned in this standard. Users of this standard are expressly advised that determination of the validity of any such patent rights, and the risk of infringement of such rights, are entirely their own responsibility.*

*This standard is subject to revision at any time by the responsible technical committee and must be reviewed every five years and if not revised, either reapproved or withdrawn. Your comments are invited either for revision of this standard or for additional standards and should be addressed to ASTM International Headquarters. Your comments will receive careful consideration at a meeting of the responsible technical committee, which you may attend. If you feel that your comments have not received a fair hearing you should make your views known to the ASTM Committee on Standards, at the address shown below.*

*This standard is copyrighted by ASTM International, 100 Barr Harbor Drive, PO Box C700, West Conshohocken, PA 19428-2959, United States. Individual reprints (single or multiple copies) of this standard may be obtained by contacting ASTM at the above address or at 610-832-9585 (phone), 610-832-9555 (fax), or service@astm.org (e-mail); or through the ASTM website (www.astm.org).*