



Designation: G 31 – 72 (Reapproved 1999)

Standard Practice for Laboratory Immersion Corrosion Testing of Metals¹

This standard is issued under the fixed designation G 31; the number immediately following the designation indicates the year of original adoption or, in the case of revision, the year of last revision. A number in parentheses indicates the year of last reapproval. A superscript epsilon (ϵ) indicates an editorial change since the last revision or reapproval.

1. Scope

1.1 This practice² describes accepted procedures for and factors that influence laboratory immersion corrosion tests, particularly mass loss tests. These factors include specimen preparation, apparatus, test conditions, methods of cleaning specimens, evaluation of results, and calculation and reporting of corrosion rates. This practice also emphasizes the importance of recording all pertinent data and provides a checklist for reporting test data. Other ASTM procedures for laboratory corrosion tests are tabulated in the Appendix.

NOTE 1—**Warning:** In many cases the corrosion product on the reactive metals titanium and zirconium is a hard and tightly bonded oxide that defies removal by chemical or ordinary mechanical means. In many such cases, corrosion rates are established by mass gain rather than mass loss.

1.2 The values stated in SI units are to be regarded as the standard. The values given in parentheses are for information only.

1.3 *This standard does not purport to address all of the safety concerns, if any, associated with its use. It is the responsibility of the user of this standard to establish appropriate safety and health practices and determine the applicability of regulatory limitations prior to use.*

2. Referenced Documents

2.1 ASTM Standards:

- A 262 Practices for Detecting Susceptibility to Intergranular Attack in Austenitic Stainless Steels³
- E 8 Test Methods for Tension Testing of Metallic Materials⁴
- G 1 Practice for Preparing, Cleaning, and Evaluating Corrosion Test Specimens⁵
- G 4 Guide for Conducting Corrosion Coupon Tests in Field Applications⁵
- G 16 Guide for Applying Statistics to Analysis of Corrosion Data⁵

¹ This practice is under the jurisdiction of ASTM Committee G-1 on Corrosion of Metals and is the direct responsibility of Subcommittee G01.05 on Laboratory Corrosion Tests.

Current edition approved May 30, 1972. Published July 1972.

² This practice is based upon NACE Standard TM-01-69, "Test Method—Laboratory Corrosion Testing of Metals for the Process Industries", with modifications to relate more directly to Practices G 1 and G 31 and Guide G 4.

³ Annual Book of ASTM Standards, Vol 01.03.

⁴ Annual Book of ASTM Standards, Vol 03.01.

⁵ Annual Book of ASTM Standards, Vol 03.02.

G 46 Guide for Examination and Evaluation of Pitting Corrosion⁵

3. Significance and Use

3.1 Corrosion testing by its very nature precludes complete standardization. This practice, rather than a standardized procedure, is presented as a guide so that some of the pitfalls of such testing may be avoided.

3.2 Experience has shown that all metals and alloys do not respond alike to the many factors that affect corrosion and that "accelerated" corrosion tests give indicative results only, or may even be entirely misleading. It is impractical to propose an inflexible standard laboratory corrosion testing procedure for general use, except for material qualification tests where standardization is obviously required.

3.3 In designing any corrosion test, consideration must be given to the various factors discussed in this practice, because these factors have been found to affect greatly the results obtained.

4. Interferences

4.1 The methods and procedures described herein represent the best current practices for conducting laboratory corrosion tests as developed by corrosion specialists in the process industries. For proper interpretation of the results obtained, the specific influence of certain variables must be considered. These include:

4.1.1 Metal specimens immersed in a specific hot liquid may not corrode at the same rate or in the same manner as in equipment where the metal acts as a heat transfer medium in heating or cooling the liquid. If the influence of heat transfer effects is specifically of interest, specialized procedures (in which the corrosion specimen serves as a heat transfer agent) must be employed (**1**).⁶

4.1.2 In laboratory tests, the velocity of the environment relative to the specimens will normally be determined by convection currents or the effects induced by aeration or boiling or both. If the specific effects of high velocity are to be studied, special techniques must be employed to transfer the environment through tubular specimens or to move it rapidly past the plane face of a corrosion coupon (**2**). Alternatively, the

⁶ The boldface numbers in parentheses refer to the list of references at the end of this practice.

coupon may be rotated through the environment, although it is then difficult to evaluate the velocity quantitatively because of the stirring effects incurred.

4.1.3 The behavior of certain metals and alloys may be profoundly influenced by the presence of dissolved oxygen. If this is a factor to be considered in a specific test, the solution should be completely aerated or deaerated in accordance with 8.7.

4.1.4 In some cases, the rate of corrosion may be governed by other minor constituents in the solution, in which case they will have to be continually or intermittently replenished by changing the solution in the test.

4.1.5 Corrosion products may have undesirable effects on a chemical product. The amount of possible contamination can be estimated from the loss in mass of the specimen, with proper application of the expected relationships among (1) the area of corroding surface, (2) the mass of the chemical product handled, and (3) the duration of contact of a unit of mass of the chemical product with the corroding surface.

4.1.6 Corrosion products from the coupon may influence the corrosion rate of the metal itself or of different metals exposed at the same time. For example, the accumulation of cupric ions in the testing of copper alloys in intermediate strengths of sulfuric acid will accelerate the corrosion of copper alloys, as compared to the rates that would be obtained if the corrosion products were continually removed. Cupric ions may also exhibit a passivating effect upon stainless steel coupons exposed at the same time. In practice, only alloys of the same general type should be exposed in the testing apparatus.

4.1.7 Coupon corrosion testing is predominantly designed to investigate general corrosion. There are a number of other special types of phenomena of which one must be aware in the design and interpretation of corrosion tests.

4.1.7.1 Galvanic corrosion may be investigated by special devices which couple one coupon to another in electrical contact. The behavior of the specimens in this galvanic couple are compared with that of insulated specimens exposed on the same holder and the galvanic effects noted. It should be observed, however, that galvanic corrosion can be greatly affected by the area ratios of the respective metals, the distance between the metals and the resistivity of the electrolyte. The coupling of corrosion coupons then yields only qualitative results, as a particular coupon reflects only the relationship between these two metals at the particular area ratio involved.

4.1.7.2 Crevice corrosion or concentration cell corrosion may occur where the metal surface is partially blocked from the corroding liquid as under a spacer or supporting hook. It is necessary to evaluate this localized corrosion separately from the overall mass loss.

4.1.7.3 Selective corrosion at the grain boundaries (for example, intergranular corrosion of sensitized austenitic stainless steels) will not be readily observable in mass loss measurements unless the attack is severe enough to cause grain dropping, and often requires microscopic examination of the coupons after exposure.

4.1.7.4 Dealloying or “parting” corrosion is a condition in which one constituent is selectively removed from an alloy, as in the dezincification of brass or the graphitization of cast iron.

Close attention and a more sophisticated evaluation than a simple mass loss measurement are required to detect this phenomenon.

4.1.7.5 Certain metals and alloys are subject to a highly localized type of attack called pitting corrosion. This cannot be evaluated by mass loss alone. The reporting of nonuniform corrosion is discussed below. It should be appreciated that pitting is a statistical phenomenon and that the incidence of pitting may be directly related to the area of metal exposed. For example, a small coupon is not as prone to exhibit pitting as a large one and it is possible to miss the phenomenon altogether in the corrosion testing of certain alloys, such as the AISI Type 300 series stainless steels in chloride contaminated environments.

4.1.7.6 All metals and alloys are subject to stress-corrosion cracking under some circumstances. This cracking occurs under conditions of applied or residual tensile stress, and it may or may not be visible to the unaided eye or upon casual inspection. A metallographic examination may confirm the presence of stress-corrosion cracking. It is imperative to note that this usually occurs with no significant loss in mass of the test coupon, although certain refractory metals are an exception to these observations. Generally, if cracking is observed on the coupon, it can be taken as positive indication of susceptibility, whereas failure to effect this phenomenon simply means that it did not occur under the duration and specific conditions of the test. Separate and special techniques are employed for the specific evaluation of the susceptibility of metals and alloys to stress corrosion cracking (see Ref. (3)).

5. Apparatus

5.1 A versatile and convenient apparatus should be used, consisting of a kettle or flask of suitable size (usually 500 to 5000 mL), a reflux condenser with atmospheric seal, a sparger for controlling atmosphere or aeration, a thermowell and temperature-regulating device, a heating device (mantle, hot plate, or bath), and a specimen support system. If agitation is required, the apparatus can be modified to accept a suitable stirring mechanism, such as a magnetic stirrer. A typical resin flask setup for this type test is shown in Fig. 1.

5.2 The suggested components can be modified, simplified, or made more sophisticated to fit the needs of a particular investigation. The suggested apparatus is basic and the apparatus is limited only by the judgment and ingenuity of the investigator.

5.2.1 A glass reaction kettle can be used where the configuration and size of the specimen will permit entry through the narrow kettle neck (for example, 45/50 ground-glass joint). For solutions corrosive to glass, suitable metallic or plastic kettles may be employed.

5.2.2 In some cases a wide-mouth jar with a suitable closure is sufficient when simple immersion tests at ambient temperatures are to be investigated.

5.2.3 Open-beaker tests should not be used because of evaporation and contamination.

5.2.4 In more complex tests, provisions might be needed for continuous flow or replenishment of the corrosive liquid, while simultaneously maintaining a controlled atmosphere.

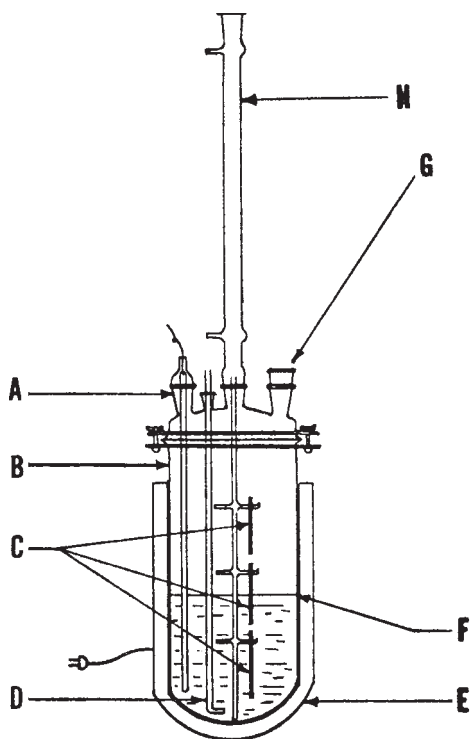

NOTE 1—The flask can be used as a versatile and convenient apparatus to conduct simple immersion tests. Configuration of top to flask is such that more sophisticated apparatus can be added as required by the specific test being conducted. A = thermowell, B = resin flask, C = specimens hung on supporting device, D = air inlet, E = heating mantle, F = liquid interface, G = opening in flask for additional apparatus that may be required, and H = reflux condenser.

FIG. 1 Typical Resin Flask

6. Sampling

6.1 The bulk sampling of products is outside the scope of this practice.

7. Test Specimen

7.1 In laboratory tests, uniform corrosion rates of duplicate specimens are usually within $\pm 10\%$ under the same test conditions. Occasional exceptions, in which a large difference is observed, can occur under conditions of borderline passivity of metals or alloys that depend on a passive film for their resistance to corrosion. Therefore, at least duplicate specimens should normally be exposed in each test.

7.2 If the effects of corrosion are to be determined by changes in mechanical properties, untested duplicate specimens should be preserved in a noncorrosive environment at the same temperature as the test environment for comparison with the corroded specimens. The mechanical property commonly used for comparison is the tensile strength. Measurement of percent elongation is a useful index of embrittlement. The procedures for determining these values are shown in detail in Test Methods E 8.

7.3 The size and shape of specimens will vary with the purpose of the test, nature of the materials, and apparatus used. A large surface-to-mass ratio and a small ratio of edge area to total area are desirable. These ratios can be achieved through

the use of square or circular specimens of minimum thickness. Masking may also be used to achieve the desired area ratios but may cause crevice corrosion problems. Circular specimens should preferably be cut from sheet and not bar stock, to minimize the exposed end grain. Special coupons (for example, sections of welded tubing) may be employed for specific purposes.

7.3.1 A circular specimen of about 38-mm (1.5-in.) diameter is a convenient shape for laboratory corrosion tests. With a thickness of approximately 3 mm (0.125-in.) and an 8-mm ($\frac{5}{16}$ -in.) or 11-mm ($\frac{7}{16}$ -in.) diameter hole for mounting, these specimens will readily pass through a 45/50 ground-glass joint of a distillation kettle. The total surface area of a circular specimen is given by the following equation:

$$A = \pi/2(D^2 - d^2) + t\pi D + t\pi d \quad (1)$$

where:

t = thickness,

D = diameter of the specimen, and

d = diameter of the mounting hole.

7.3.1.1 If the hole is completely covered by the mounting support, the last term ($t\pi d$) in the equation is omitted.

7.3.2 Strip coupons 50 by 25 by 1.6 or 3 mm (2 by 1 by $\frac{1}{16}$ or $\frac{1}{8}$ in.) may be preferred as corrosion specimens, particularly if interface or liquid line effects are to be studied by the laboratory tests (see Fig. 1), but the evaluation of such specific effects are beyond the scope of this practice.

7.3.3 All specimens should be measured carefully to permit accurate calculation of the exposed areas. A geometric area calculation accurate to $\pm 1\%$ is usually adequate.

7.4 More uniform results may be expected if a substantial layer of metal is removed from the specimens to eliminate variations in condition of the original metallic surface. This can be done by chemical treatment (pickling), electrolytic removal, or by grinding with a coarse abrasive paper or cloth such as No. 50, using care not to work harden the surface (see section 5.7). At least 0.0025 mm (0.0001 in.) or 0.0155 to 0.0233 mg/mm² (10 to 15 mg/in.²) should be removed. (If clad alloy specimens are to be used, special attention must be given to ensure that excessive metal is not removed.) After final preparation of the specimen surface, the specimens should be stored in a desiccator until exposure, if they are not used immediately. In special cases (for example, for aluminum and certain copper alloys), a minimum of 24 h storage in a desiccator is recommended. The choice of a specific treatment must be considered on the basis of the alloy to be tested and the reasons for testing. A commercial surface may sometimes yield the most significant results. Too much surface preparation may remove segregated elements, surface contamination, etc., and therefore not be representative.

7.5 Exposure of sheared edges should be avoided unless the purpose of the test is to study effects of the shearing operation. It may be desirable to test a surface representative of the material and metallurgical conditions used in practice.

7.6 The specimen can be stamped with an appropriate identifying mark. If metallic contamination of the stamped area may influence the corrosion behavior, chemical cleaning must be employed to remove any traces of foreign particles from the

surface of the coupon (for example, by immersion of stainless steel coupons in dilute nitric acid following stamping with steel dies).

7.6.1 The stamp, besides identifying the specimen, introduces stresses and cold work in the specimen that could be responsible for localized corrosion or stress-corrosion cracking, or both.

7.6.2 Stress-corrosion cracking at the identifying mark is a positive indication of susceptibility to such corrosion. However, the absence of cracking should not be interpreted as indicating resistance (see 4.1.7.6).

7.7 Final surface treatment of the specimens should include finishing with No. 120 abrasive paper or cloth or the equivalent, unless the surface is to be used in the mill finished condition. This resurfacing may cause some surface work hardening, to an extent which will be determined by the vigor of the surfacing operation, but is not ordinarily significant. The surface finish to be encountered in service may be more appropriate for some testing.

7.7.1 Coupons of different alloy compositions should never be ground on the same cloth.

7.7.2 Wet grinding should be used on alloys which work harden quickly, such as the austenitic stainless steels.

7.8 The specimens should be finally degreased by scrubbing with bleach-free scouring powder, followed by thorough rinsing in water and in a suitable solvent (such as acetone, methanol, or a mixture of 50 % methanol and 50 % ether), and air dried. For relatively soft metals (such as aluminum, magnesium, and copper), scrubbing with abrasive powder is not always needed and can mar the surface of the specimen. Proper ultrasonic procedures are an acceptable alternate. The use of towels for drying may introduce an error through contamination of the specimens with grease or lint.

7.9 The dried specimens should be weighed on an analytical balance to an accuracy of at least ± 0.5 mg. If cleaning deposits (for example, scouring powder) remain or lack of complete dryness is suspected, then recleaning and drying is performed until a constant mass is attained.

7.10 The method of specimen preparation should be described when reporting test results, to facilitate interpretation of data by other persons.

7.11 The use of welded specimens is sometimes desirable, because some welds may be cathodic or anodic to the parent metal and may affect the corrosion rate.

7.11.1 The heat-affected zone is also of importance but should be studied separately, because welds on coupons do not faithfully reproduce heat input or size effects of full-size weldments.

7.11.2 Corrosion of a welded coupon is best reported by description and thickness measurements rather than a millimetre per year (mils per year) rate, because the attack is normally localized and not representative of the entire surface.

7.11.3 A complete discussion of corrosion testing of welded coupons or the effect of heat treatment on the corrosion resistance of a metal is not within the scope of this practice.

8. Test Conditions

8.1 Selection of the conditions for a laboratory corrosion test will be determined by the purpose of the test.

8.1.1 If the test is to be a guide for the selection of a material for a particular purpose, the limits of the controlling factors in service must be determined. These factors include oxygen concentration, temperature, rate of flow, pH value, composition, and other important characteristics of the solution.

8.2 An effort should be made to duplicate all pertinent service conditions in the corrosion test.

8.3 It is important that test conditions be controlled throughout the test in order to ensure reproducible results.

8.4 The spread in corrosion rate values for duplicate specimens in a given test probably should not exceed ± 10 % of the average when the attack is uniform.

8.5 Composition of Solution:

8.5.1 Test solutions should be prepared accurately from chemicals conforming to the Specifications of the Committee on Analytical Reagents of the American Chemical Society⁷ and distilled water, except in those cases where naturally occurring solutions or those taken directly from some plant process are used.

8.5.2 The composition of the test solutions should be controlled to the fullest extent possible and should be described as completely and as accurately as possible when the results are reported.

8.5.2.1 Minor constituents should not be overlooked because they often affect corrosion rates.

8.5.2.2 Chemical content should be reported as percentage by weight of the solutions. Molarity and normality are also helpful in defining the concentration of chemicals in some test solutions.

8.5.3 If problems are suspected, the composition of the test solutions should be checked by analysis at the end of the test to determine the extent of change in composition, such as might result from evaporation or depletion.

8.5.4 Evaporation losses may be controlled by a constant level device or by frequent addition of appropriate solution to maintain the original volume within ± 1 %. Preferably, the use of a reflux condenser ordinarily precludes the necessity of adding to the original kettle charge.

8.5.5 In some cases, composition of the test solution may change as a result of catalytic decomposition or by reaction with the test coupons. These changes should be determined if possible. Where required, the exhausted constituents should be added or a fresh solution provided during the course of the test.

8.5.6 When possible, only one type of metal should be exposed in a given test (see 4.1.6).

8.6 Temperature of Solution:

8.6.1 Temperature of the corroding solution should be controlled within $\pm 1^\circ\text{C}$ ($\pm 1.8^\circ\text{F}$) and must be stated in the report of test results.

⁷ *Reagent Chemicals, American Chemical Society Specifications*, American Chemical Society, Washington, DC. For suggestions on the testing of reagents not listed by the American Chemical Society, see *Analar Standards for Laboratory Chemicals*, BDH Ltd., Poole, Dorset, U.K., and the *United States Pharmacopeia and National Formulary*, U.S. Pharmacopeial Convention, Inc. (USPC), Rockville, MD.

8.6.2 If no specific temperature, such as boiling point, is required or if a temperature range is to be investigated, the selected temperatures used in the test, and their respective duration, must be reported.

8.6.3 For tests at ambient temperature, the tests should be conducted at the highest temperature anticipated for stagnant storage in summer months. This temperature may be as high as from 40 to 45°C (104 to 113°F) in some areas. The variation in temperature should be reported also (for example, 40 ± 2°C).

8.7 *Aeration of Solution:*

8.7.1 Unless specified, the solution should not be aerated. Most tests related to process equipment should be run with the natural atmosphere inherent in the process, such as the vapors of the boiling liquid.

8.7.2 If aeration is employed, the specimen should not be located in the direct air stream from the sparger. Extraneous effects can be encountered if the air stream impinges on the specimens.

8.7.3 If exclusion of dissolved oxygen is necessary, specific techniques are required, such as prior heating of the solution and sparging with an inert gas (usually nitrogen). A liquid atmospheric seal is required on the test vessel to prevent further contamination.

8.7.4 If oxygen saturation of the test solution is desired, this can best be achieved by sparging with oxygen. For other degrees of aeration, the solution should be sparged with air or synthetic mixtures of air or oxygen with an inert gas. Oxygen saturation is a function of the partial pressure of oxygen in the gas.

8.8 *Solution Velocity:*

8.8.1 The effect of velocity is not usually determined in normal laboratory tests, although specific tests have been designed for this purpose.

8.8.2 Tests at the boiling point should be conducted with the minimum possible heat input, and boiling chips should be used to avoid excessive turbulence and bubble impingement.

8.8.3 In tests below the boiling point, thermal convection generally is the only source of liquid velocity.

8.8.4 In test solutions with high viscosity, supplemental controlled stirring with a magnetic stirrer is recommended.

8.9 *Volume of Test Solution:*

8.9.1 The volume of the test solution should be large enough to avoid any appreciable change in its corrosivity during the test, either through exhaustion of corrosive constituents or by accumulation of corrosion products that might affect further corrosion.

8.9.2 Two examples of a minimum “solution volume-to-specimen area” ratio are 0.20 mL/mm² (125 mL/in.²) of specimen surface (Practice A 262), and 0.40 mL/mm² (250 mL/in.²).

8.9.3 When the test objective is to determine the effect of a metal or alloy on the characteristics of the test solution (for example, to determine the effects of metals on dyes), it is desirable to reproduce the ratio of solution volume to exposed metal surface that exists in practice. The actual time of contact of the metal with the solution must also be taken into account. Any necessary distortion of the test conditions must be considered when interpreting the results.

8.10 *Method of Supporting Specimens:*

8.10.1 The supporting device and container should not be affected by or cause contamination of the test solution.

8.10.2 The method of supporting specimens will vary with the apparatus used for conducting the test, but should be designed to insulate the specimens from each other physically and electrically and to insulate the specimens from any metallic container or supporting device used within the apparatus.

8.10.3 Shape and form of the specimen support should assure free contact of the specimen with the corroding solution, the liquid line, or the vapor phase as shown in Fig. 1. If clad alloys are exposed, special procedures will be required to ensure that only the cladding is exposed, unless the purpose is to test the ability of the cladding to protect cut edges in the test solution.

8.10.4 Some common supports are glass or ceramic rods, glass saddles, glass hooks, fluorocarbon plastic strings, and various insulated or coated metallic supports.

8.11 *Duration of Test:*

8.11.1 Although duration of any test will be determined by the nature and purpose of the test, an excellent procedure for evaluating the effect of time on corrosion of the metal and also on the corrosiveness of the environment in laboratory tests has been presented by Wachter and Treseder (4). This technique is called the “planned interval test,” and the procedure and evaluation of results are given in Table 1. Other procedures that require the removal of solid corrosion products between exposure periods will not measure accurately the normal changes of corrosion with time.

8.11.2 Materials that experience severe corrosion generally do not ordinarily need lengthy tests to obtain accurate corrosion rates. However, there are cases where this assumption is not valid. For example, lead exposed to sulfuric acid corrodes at an extremely high rate at first, while building a protective film; then the rates decrease considerably so that further corrosion is negligible. The phenomenon of forming a protective film is observed with many corrosion-resistant materials. Therefore, short tests on such materials would indicate a high corrosion rate and be completely misleading.

8.11.3 Short-time tests also can give misleading results on alloys that form passive films, such as stainless steels. With borderline conditions, a prolonged test may be needed to permit breakdown of the passive film and subsequent more rapid attack. Consequently, tests run for long periods are considerably more realistic than those conducted for short durations. This statement must be qualified by stating that corrosion should not proceed to the point where the original specimen size or the exposed area is drastically reduced or where the metal is perforated.

8.11.4 If anticipated corrosion rates are moderate or low, the following equation gives the suggested test duration:

$$\text{Hours} = 2000 / (\text{corrosion rate in mpy}) \quad (2)$$

where mpy = mils per year (see 11.2.1 and Note 2 for conversion to other units).

8.11.4.1 *Example*—Where the corrosion rate is 0.25 mm/y (10 mpy), the test should run for at least 200 h.

8.11.4.2 This method of estimating test duration is useful only as an aid in deciding, after a test has been made, whether

TABLE 1 Planned Interval Corrosion Test

(Reprinted by permission from Chemical Engineering Progress, June 1947)

Identical specimens all placed in the same corrosive fluid. Imposed conditions of the test kept constant for entire time $t + 1$. Letters, A_1 , A_t , A_{t+1} , B , represent corrosion damage experienced by each test specimen. A_2 is calculated by subtracting A_t from A_{t+1} .

Occurrences During Corrosion Test		Criteria
Liquid corrosiveness	unchanged	$A_1 = B$
	decreased	$B < A_1$
	increased	$A_1 < B$
Metal corrodibility	unchanged	$A_2 = B$
	decreased	$A_2 < B$
	increased	$B < A_2$

Combinations of Situations		
Liquid corrosiveness	Metal corrodibility	Criteria
1. unchanged	unchanged	$A_1 = A_2 = B$
2. unchanged	decreased	$A_2 < A_1 = B$
3. unchanged	increased	$A_1 = B < A_2$
4. decreased	unchanged	$A_2 = B < A_1$
5. decreased	decreased	$A_2 < B < A_1$
6. decreased	increased	$A_1 > B < A_2$
7. increased	unchanged	$A_1 < A_2 = B$
8. increased	decreased	$A_1 < B > A_2$
9. increased	increased	$A_1 < B < A_2$

Example; Conditions: Duplicate strips of low-carbon steel, each 19 by 76 mm ($\frac{3}{4}$ by 3 in.), immersed in 200 mL of 10 % $AlCl_3$ -90 % $SbCl_3$ mixture through which dried HCl gas was slowly bubbled at atmospheric pressure. Temperature 90°C.

	Interval, days	Mass Loss, mg	Penetration, mm (mils)	Apparent Corrosion Rate, mm/y (mpy)
A_1	0-1	1080	.043 (1.69)	15.7 (620)
A_t	0-3	1430	.057 (2.24)	6.9 (270)
A_{t+1}	0-4	1460	.058 (2.29)	5.3 (210)
B	3-4	70	.003 (0.11)	1.0 (40)
A_2	calc. 3-4	30	.001 (0.05)	0.5 (18)

Example: $A_2 < B < A_1$
 $.001 < .003 < .043$ ($0.05 < 0.11 < 1.69$)

Therefore, liquid markedly decreased in corrosiveness during test, and formation of partially protective scale on the steel was indicated.

or not it is desirable to repeat the test for a longer period. The most common testing periods are 48 to 168 h (2 to 7 days).

8.11.5 In some cases, it may be necessary to know the degree of contamination caused by the products of corrosion. This can be accomplished by analysis of the solution after corrosion has occurred. The corrosion rate can be calculated from the concentration of the matrix metal found in the solution and it can be compared to that determined from the mass loss of the specimens. However, some of the corrosion products usually adhere to the specimen as a scale and the corrosion rate calculated from the metal content in the solution is not always correct.

8.12 The design of corrosion testing programs is further discussed in Guide G 16.

9. Methods of Cleaning Specimens after Test

9.1 Before specimens are cleaned, their appearance should be observed and recorded. Location of deposits, variations in types of deposits, or variations in corrosion products are

extremely important in evaluating localized corrosion, such as pitting and concentration cell attack.

9.2 Cleaning specimens after the test is a vital step in the corrosion test procedure and if not done properly, can cause misleading results.

9.2.1 Generally, the cleaning procedure should remove all corrosion products from specimens with a minimum removal of sound metal.

9.2.2 Set rules cannot be applied to specimen cleaning, because procedures will vary, depending on the type of metal being cleaned and on the degree of adherence of corrosion products.

9.3 Cleaning methods can be divided into three general categories: mechanical, chemical, and electrolytic.

9.3.1 Mechanical cleaning includes scrubbing, scraping, brushing, mechanical shocking, and ultrasonic procedures. Scrubbing with a bristle brush and mild abrasive is the most popular of these methods. The others are used principally as a supplement to remove heavily encrusted corrosion products before scrubbing. Care should be used to avoid the removal of sound metal.

9.3.2 Chemical cleaning implies the removal of material from the surface of the specimen by dissolution in an appropriate chemical solution. Solvents such as acetone, carbon tetrachloride, and alcohol are used to remove oil, grease, or resin and are usually applied prior to other methods of cleaning. Chemicals are chosen for application to a specific material. Methods for chemical cleaning after testing of specific metals and alloys are described in Practice G 1.

9.3.3 Electrolytic cleaning should be preceded by scrubbing to remove loosely adhering corrosion products. A method of electrolytic cleaning is described in Practice G 1.

9.3.3.1 Precautions must be taken to ensure good electrical contact with the specimen, to avoid contamination of the solution with easily reducible metal ions, and to ensure that inhibitor decomposition has not occurred.

9.4 Whatever treatment is used to clean specimens after a corrosion test, its effect in removing metal should be determined and the mass loss should be corrected accordingly. A "blank" specimen should be weighed before and after exposure to the cleaning procedure to establish this mass loss (see also Practice G 1). Careful observation is needed to ensure that pitting does not occur during cleaning.

9.4.1 Following removal of all scale, the specimen should be treated as discussed in 5.8.

9.4.2 The description of the cleaning method should be included with the data reported.

10. Interpretation of Results

10.1 After corroded specimens have been cleaned, they should be reweighed with an accuracy corresponding to that of the original weighing. The mass loss during the test period can be used as the principal measure of corrosion.

10.2 After the specimens have been reweighed, they should be examined carefully for the presence of any pits. If there are any pits, the average and maximum depths of pits are determined with a pit gage or a calibrated microscope which can be focused first on the edges and then on the bottoms of the pits. The degree of lateral spreading of pits may also be noted.

10.2.1 Pit depths should be reported in millimeters or thousandths of an inch for the test period and not interpolated or extrapolated to millimeters per year, thousandths of an inch per year, or any other arbitrary period because rarely, if ever, is the rate of initiation or propagation of pits uniform.

10.2.2 The size, shape, and distribution of pits should be noted. A distinction should be made between those occurring underneath the supporting devices (concentration cells) and those on the surfaces that were freely exposed to the test solution (see Guide G 46).

10.3 If the material being tested is suspected of being subject to dealloying forms of corrosion such as dezincification or to intergranular attack, a cross section of the specimen should be microscopically examined for evidence of such attack.

10.4 The specimen may be subjected to simple bending tests to determine whether any embrittlement attack has occurred.

10.5 It may be desirable to make quantitative mechanical tests, comparing the exposed specimens with uncorroded specimens reserved for the purpose, as described in 7.2.

11. Calculating Corrosion Rates

11.1 Calculating corrosion rates requires several pieces of information and several assumptions:

11.1.1 The use of corrosion rates implies that all mass loss has been due to general corrosion and not to localized corrosion, such as pitting or intergranular corrosion of sensitized areas on welded coupons. Localized corrosion is reported separately.

11.1.2 The use of corrosion rates also implies that the material has not been internally attacked as by dezincification or intergranular corrosion.

11.1.3 Internal attack can be expressed as a corrosion rate if desired. However, the calculations must not be based on mass loss (except in qualification tests such as Practices A 262), which is usually small but on microsections which show depth of attack.

11.2 Assuming that localized or internal corrosion is not present or is recorded separately in the report, the average corrosion rate can be calculated by the following equation:

$$\text{Corrosion rate} = (K \times W)/(A \times T \times D) \quad (3)$$

where:

- K = a constant (see below)
- T = time of exposure in hours to the nearest 0.01 h,
- A = area in cm^2 to the nearest 0.01 cm^2 ,
- W = mass loss in g, to nearest 1 mg (corrected for any loss during cleaning (see 9.4)), and
- D = density in g/cm^3 , (see Appendix X1 of Practice G 1).

11.2.1 Many different units are used to express corrosion rates. Using the above units for T , A , W , and D , the corrosion rate can be calculated in a variety of units with the following appropriate value of K :

Corrosion Rate Units Desired	Constant (K) in Corrosion Rate Equation
mils per year (mpy)	3.45×10^6
inches per year (ipy)	3.45×10^3
inches per month (ipm)	2.87×10^2

millimetres per year (mm/y)	8.76×10^4
micrometres per year ($\mu\text{m}/\text{y}$)	8.76×10^7
picometres per second (pm/s)	2.78×10^6
grams per square metre per hour ($\text{g}/\text{m}^2\text{-h}$)	$1.00 \times 10^4 \times D^A$
milligrams per square decimetre per day (mdd)	$2.40 \times 10^6 \times D^A$
micrograms per square metre per second ($\mu\text{g}/\text{m}^2\text{-s}$)	$2.78 \times 10^6 \times D^A$

^A Density is not needed to calculate the corrosion rate in these units. The density in the constant K cancels out the density in the corrosion rate equation.

NOTE 2—If desired, these constants may also be used to convert corrosion rates from one set of units to another. To convert a corrosion rate in units X to a rate of units Y , multiply by K_Y/K_X for example:

$$\begin{aligned} 15 \text{ mpy} &= 15 \times [(2.78 \times 10^6)/(3.45 \times 10^6)] \text{ pm/s} \\ &= 12.1 \text{ pm/s} \end{aligned} \quad (4)$$

12. Report

12.1 The importance of reporting all data as completely as possible cannot be overemphasized.

12.2 Expansion of the testing program in the future or correlating the results with tests of other investigators will be possible only if all pertinent information is properly recorded.

12.3 The following checklist is a recommended guide for reporting all important information and data.

12.3.1 Corrosive media and concentration (any changes during test).

12.3.2 Volume of test solution.

12.3.3 Temperature (maximum, minimum, average).

12.3.4 Aeration (describe conditions or technique).

12.3.5 Agitation (describe conditions or technique).

12.3.6 Type of apparatus used for test.

12.3.7 Duration of each test.

12.3.8 Chemical composition or trade name of metals tested.

12.3.9 Form and metallurgical conditions of specimens.

12.3.10 Exact size, shape, and area of specimens.

12.3.11 Treatment used to prepare specimens for test.

12.3.12 Number of specimens of each material tested, and whether specimens were tested separately or which specimens tested in the same container.

12.3.13 Method used to clean specimens after exposure and the extent of any error expected by this treatment.

12.3.14 Initial and final masses and actual mass losses for each specimen.

12.3.15 Evaluation of attack if other than general, such as crevice corrosion under support rod, pit depth and distribution, and results of microscopical examination or bend tests.

12.3.16 Corrosion rates for each specimen.

12.4 Minor occurrences or deviations from the proposed test program often can have significant effects and should be reported if known.

12.5 Statistics can be a valuable tool for analyzing the results from test programs designed to generate adequate data. Excellent references for the use of statistics in corrosion studies include Ref. (5-7) and in Guide G 16.

13. Keywords

13.1 accelerated; immersion; laboratory; mass loss; metals; pitting

REFERENCES

- (1) Fisher, A. O., and Whitney, Jr., F. L., "Laboratory Methods for Determining Corrosion Rates Under Heat Flux Conditions," *Corrosion*, Vol 15, No. 5, May 1959, p. 257t.
- (2) U.S. Patent 3,228,236, 1969.
- (3) "Stress Corrosion Test Environments and Test Durations," *Symposium on Stress Corrosion Testing, ASTM STP 425*, ASTM, 1967.
- (4) Wachter, A., and Treseder, R. S., "Corrosion Testing Evaluation of Metals for Process Equipment," *Chemical Engineering Progress*, Vol 43, June 1947, pp. 315–326.
- (5) Mickley, H. S., Sherwood, T. K., and Reed, C. E. editors, *Applied Mathematics in Chemical Engineering* 2nd Edition, McGraw-Hill Book Co., New York, NY 1957.
- (6) Youden, W. J., *Experimentation and Measurement*, National Science Teachers Assn., Washington, DC, 1962.
- (7) Booth, F. F., and Tucker, G. E. G., "Statistical Distribution of Endurance in Electrochemical Stress-Corrosion Tests," *Corrosion*, Vol 21, No. 5, May 1965, pp. 173–177.
- (8) Champion, F. A., *Corrosion Testing Procedures*, 2nd Edition, John Wiley & Sons, Inc., New York, NY, 1965.

The American Society for Testing and Materials takes no position respecting the validity of any patent rights asserted in connection with any item mentioned in this standard. Users of this standard are expressly advised that determination of the validity of any such patent rights, and the risk of infringement of such rights, are entirely their own responsibility.

This standard is subject to revision at any time by the responsible technical committee and must be reviewed every five years and if not revised, either reapproved or withdrawn. Your comments are invited either for revision of this standard or for additional standards and should be addressed to ASTM Headquarters. Your comments will receive careful consideration at a meeting of the responsible technical committee, which you may attend. If you feel that your comments have not received a fair hearing you should make your views known to the ASTM Committee on Standards, 100 Barr Harbor Drive, West Conshohocken, PA 19428.

This standard is copyrighted by ASTM, 100 Barr Harbor Drive, West Conshohocken, PA 19428-2959, United States. Individual reprints (single or multiple copies) of this standard may be obtained by contacting ASTM at the above address or at 610-832-9585 (phone), 610-832-9555 (fax), or service@astm.org (e-mail); or through the ASTM website (<http://www.astm.org>).