



Standard Practice for Evaluating Stress-Corrosion-Cracking Resistance of Metals and Alloys in a Boiling Magnesium Chloride Solution¹

This standard is issued under the fixed designation G 36; the number immediately following the designation indicates the year of original adoption or, in the case of revision, the year of last revision. A number in parentheses indicates the year of last reapproval. A superscript epsilon (ϵ) indicates an editorial change since the last revision or reapproval.

1. Scope

1.1 This practice describes a procedure for conducting stress-corrosion cracking tests in a boiling magnesium chloride solution. Although this test may be performed using various concentrations of magnesium chloride, this procedure covers a test solution held at a constant boiling temperature of $155.0 \pm 1.0^\circ\text{C}$ ($311.0 \pm 1.8^\circ\text{F}$). The boiling points of aqueous magnesium chloride solutions at one atmosphere pressure as a function of concentration are shown graphically in Fig. 1.² A suggested test apparatus capable of maintaining solution concentration and temperature within the prescribed limits for extended periods of time is also described herein.³

1.2 The boiling magnesium chloride test is applicable to wrought, cast, and welded stainless steels and related alloys. It is a method for detecting the effects of composition, heat treatment, surface finish, microstructure, and stress on the susceptibility of these materials to chloride stress corrosion cracking.⁴

1.3 This practice is concerned primarily with the test solution, which may be used with a variety of stress corrosion test specimens, surface finishes, and methods of applying stress.

1.4 *This standard does not purport to address all of the safety concerns, if any, associated with its use. It is the responsibility of the user of this standard to establish appropriate safety and health practices and determine the applicability of regulatory limitations prior to use.* See Section 7 for specific safety precautions.

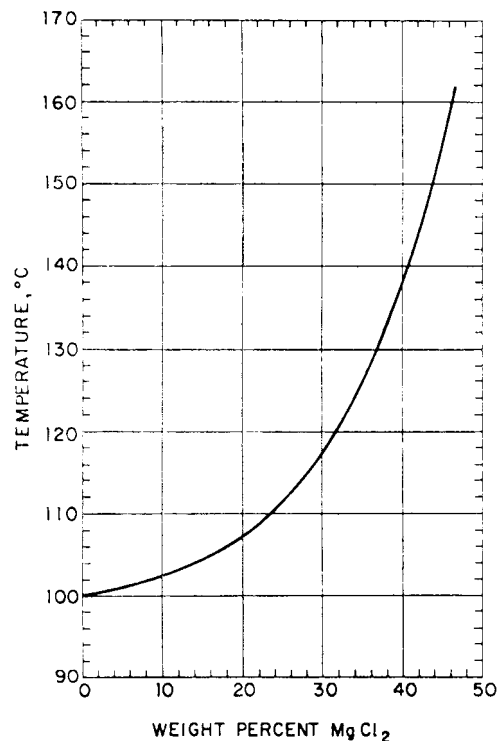

FIG. 1 Boiling Points of Aqueous Magnesium Chloride Solutions at One Atmosphere as a Function of Concentration²

2. Referenced Documents

2.1 ASTM Standards:

D 1193 Specification for Reagent Water⁵

G 1 Practice for Preparing, Cleaning, and Evaluating Corrosion Test Specimens⁶

G 15 Terminology Relating to Corrosion and Corrosion Testing⁶

G 30 Practice for Making and Using U-Bend Stress-Corrosion Test Specimens⁵

3. Terminology

3.1 *Definitions:* For definitions of terms used in this practice see Terminology G 15.

¹ This practice is under the jurisdiction of ASTM Committee G-1 on Corrosion of Metals, and is the direct responsibility of Subcommittee G01.06 on Stress Corrosion Cracking and Corrosion Fatigue.

Current edition approved Feb. 15, 1994. Published April 1994. Originally published as G 36 – 73. Last previous edition G 36 – 87.

² Available data on the relationship of concentrations and boiling points of magnesium chloride solutions are critically reviewed and supplemented by I. B. Casale in "Boiling Points of Magnesium Chloride Solutions—Their Application in Stress Corrosion Studies," *Corrosion*, Vol 23, 1967, pp. 314–17.

³ The apparatus and test procedures for maintaining constant boiling temperatures of magnesium chloride solutions for stress corrosion tests are described by M. A. Streicher and A. J. Sweet in *Corrosion*, Vol 25, 1969, pp. 1–6.

⁴ The use of concentrated magnesium chloride solutions for determining the susceptibility to stress corrosion cracking of austenitic and ferritic stainless steels and related nickel-base alloys was first described by M. A. Scheil, *Symposium on Stress Corrosion Cracking of Metals*, ASTM STP 64, ASTM, 1945, p. 395. (Although currently out of print, copies may be obtained from University Microfilms, Inc., 300 North Zeeb Rd., Ann Arbor, MI 48106.)

⁵ *Annual Book of ASTM Standards*, Vol 11.01.

⁶ *Annual Book of ASTM Standards*, Vol 03.02.

4. Summary of Practice

4.1 A predetermined quantity of reagent grade magnesium chloride and some distilled water are added to a container. The container and contents, with thermometer and condenser affixed, are placed on a source of heat. When the magnesium chloride solution boils, it is adjusted to maintain the desired concentration and boiling point through the addition of small quantities of either water or salt.

4.2 After the solution has stabilized at the desired boiling point for the test, the stressed specimens are added. Depending upon the intent of the test, the specimens should be given periodic inspections. If the duration of test exceeds 7 days, the solution should either be changed or the suggested or similar test apparatus used.

5. Significance and Use

5.1 For most applications, this environment provides an accelerated method of ranking the relative degree of stress-corrosion cracking susceptibility for stainless steels and related alloys in aqueous chloride-containing environments. Materials that normally provide acceptable resistance in hot chloride service may crack in this test. The test may not be relevant to stress-corrosion cracking in polythionic acid or caustic environments.

5.2 Resistance to stress-corrosion cracking in boiling magnesium chloride (155.0°C (311.0°F)) should, where possible, be correlated to resistance in service for the materials of interest. However, such correlations may not always be possible.

5.3 Boiling magnesium chloride may also cause pitting of many stainless alloys. This leads to the possibility of confusing stress-corrosion failures with mechanical failures induced by corrosion-reduced net cross sections. This danger is particularly great when small cross section samples, high applied stress levels, long exposure periods, stress-corrosion resistant alloys, or a combination thereof are being used. Careful examination is recommended for correct diagnosis of the cause of failure.

6. Apparatus

6.1 Any inert, transparent apparatus with provisions for a thermometer and water-cooled condenser can be used, provided that it has been designed to contain the stressed specimen while maintaining a constant temperature and concentration of the magnesium chloride solution by minimizing or preventing losses of condensate and water vapor during prolonged periods of test. Small losses of water from a solution of magnesium chloride will lead to large increases in the boiling point of the solution with a reduction in the time to failure of a specimen by stress corrosion cracking. A suggested apparatus, shown in Fig. X1.1, meets these requirements. Design details of this apparatus are given in Appendix X1.

7. Reagents

7.1 *Purity of Reagents*—Reagent grade chemicals shall be used in all tests. Unless otherwise indicated, it is intended that all reagents shall conform to the specifications of the Committee on Analytical Reagents of the American Chemical Society,

where such specifications are available.⁷ Other grades may be used, provided it is first ascertained that the reagent is of sufficiently high purity to permit its use without lessening the accuracy of the determination.

7.2 *Purity of Water*—Reagent water Type IV (Specification D 1193) shall be used to prepare the test solutions.

7.3 *Magnesium Chloride* (MgCl₂·6H₂O)—A solution of magnesium chloride that boils at 155.0 ± 1.0°C (311.0 ± 1.8°F) is used in this test. A second 25 weight percent solution of magnesium chloride is required for the trap if the test duration exceeds seven days without a solution change and the suggested apparatus is used.

7.3.1 To prepare about 400 mL of the test solution for use in a 1-L Erlenmeyer flask or other container, weigh 600 g of reagent grade MgCl₂·6H₂O and add this to the flask containing a thermometer along with 15 mL of reagent water.

7.3.2 Add 10 to 15 boiling chips or other boiling aids.

7.3.3 Heat by placing the flask on a hot plate or other suitable source of heat and put the condenser in place, leaving off the trap. Hook up the cooling water supply to the condenser.

7.3.4 When the solution boils vigorously and there is no more dripping of condensate, slowly add small quantities (4 to 5 mL) of reagent water at the top of the condenser to reduce the temperature to 155.0°C (311.0°F). Use extreme caution when adding the water to the boiling magnesium chloride solution. Cool water can form a layer on top of the magnesium chloride, and when it reaches the bottom of the flask, bumping can occur. Use a protective shield.

NOTE 1—If too much water has been added, add some crystals of MgCl₂·6H₂O through the condenser until a temperature of 155.0°C (311.0°F) is attained.

7.4 To prepare the 25 weight percent solution for the trap (Fig. X1.3), place 53.4 g of MgCl₂·6H₂O and 46.6 mL of reagent water in a flask and allow the crystals to dissolve at room temperature.

8. Safety Precautions

8.1 When cold, magnesium chloride can be handled with the minimum protective equipment of rubber gloves and goggles. Maximum protective measures should be taken to prevent boiling magnesium chloride from coming into contact with the skin. Severe burns can result as the hot magnesium chloride adheres to the skin forming a crust which causes deep burns. The severity of the burns can be reduced by taking proper and immediate first aid measures and by contacting a physician.

8.1.1 In the advent of a spill or accident, *the hot magnesium chloride should be quickly flushed from the skin with large quantities of cold water to minimize the burning, followed by immediate first aid and medical attention.*

8.1.2 All heating or boiling of magnesium chloride should be done in a shielded area with protection by hood or shield, or both.

⁷ *Reagent Chemicals, American Chemical Society Specifications*, American Chemical Society, Washington, DC. For suggestions on the testing of reagents not listed by the American Chemical Society, see *Analar Standards for Laboratory Chemicals*, BDH Ltd., Poole, Dorset, U.K., and the *United States Pharmacopoeia and National Formulary*, U.S. Pharmacopoeial Convention, Inc. (USPC), Rockville, MD.

8.1.3 Minimum personal protective equipment for handling boiling magnesium chloride should include safety glasses or goggles, face shield, laboratory coat, and rubber gloves with cotton inner gloves.

8.1.4 Disposal of the magnesium chloride should be accomplished in accordance with the material safety data supplied with the chemical or by the chemical manufacturer or supplier.

8.1.5 *Do not* remelt the solidified magnesium chloride. Localized melting adjacent to the heat source and below the solid layer of magnesium chloride can cause sufficient stresses through volume expansion to crack the containing vessel.

9. Test Specimens

9.1 Any type of stress corrosion test specimen can be used with this test solution.⁸ See Practice G 1 and G 30.

9.2 The test specimen must be thick enough so that the applied stress does not cause mechanical rupture when the cross section is reduced by pitting or general corrosion.

9.3 Whenever possible, only one specimen should be tested in each flask. If more than one specimen is tested in a flask, the specimens should be of the same alloy in order to avoid the possible deleterious effects of the corrosion products of one alloy on the performance of the other alloy.

9.4 The test specimens must be kept from direct contact with heated surfaces by glass supports. Metal specimen holders used for stressing specimens should also be supported on glass rods or tubes. The design for two types of test specimens that can be used with the suggested apparatus can be found in footnote 3.

10. Procedure

10.1 Collect the apparatus and test specimens in preparation for the test. If the suggested test apparatus is used, assemble as

⁸ For a comprehensive discussion of the various types of test specimens available, see "Stress Corrosion Testing Methods," *Stress Corrosion Testing, ASTM STP 425*, ASTM. (Although currently out of print, copies may be obtained from University Microfilms, Inc., 300 North Zeeb Rd., Ann Arbor, MI 48106.) See also Section 2 of this practice.

outlined in Appendix X1.

10.2 Prepare the test solution by adding a known quantity of reagent grade $MgCl_2 \cdot 6H_2O$, reagent water, and some boiling aids to the container fitted with a thermometer and water-cooled condenser. After applying heat, adjust the concentration of the solution by slowly adding small quantities (4 to 5 mL) of distilled water until the solution reaches the constant-boiling temperature of $155 \pm 1.0^\circ C$ ($311.0 \pm 1.8^\circ F$). Now place the previously prepared test specimens in the container.

11. Report

11.1 Record starting time, type of specimen, stress, and type exposure. A clear distinction must be made in the type of exposure; that is, complete immersion, vapor phase exposure, or a combination of immersion and exposure to the vapor phase. The time required to initiate cracks, the rate of crack growth, and the time to failure may be of importance, depending upon the purpose of the test.

11.1.1 Periodic removal of the specimen from the solution may be necessary to determine the time when cracks first appear and the rate of crack propagation. Microscopic examination of polished surfaces is required to detect crack initiation. All stressed surfaces should be examined at magnifications up to $20\times$. Metallographic examination of exposed surfaces and of polished and etched cross sections at higher magnifications are necessary at the end of the test to establish the type of cracking: transgranular, intergranular, or mixed.

11.1.2 Ruptured specimens should also be examined for evidence of mechanical failure resulting from the action of applied stress on specimens whose cross sections have been reduced by general or pitting corrosion, or both. Such failures usually show evidence of ductility. Duplicate tests with thicker specimens should be made in case of doubt.

12. Keywords

12.1 accelerated test; apparatus; boiling magnesium chloride; glassware; nickel containing alloy; stainless steels; stress-corrosion cracking

APPENDIX

(Nonmandatory Information)

X1. TEST APPARATUS

X1.1 The following test apparatus is suggested for its ability to maintain a constant temperature and solution concentration over a long period of time. Use of this apparatus is not mandatory and is presented here only as a guide.

X1.2 The suggested test apparatus is shown in Fig. X1.1 and the design details are given below:

X1.2.1 *Flask*—the 1-L Erlenmeyer flask (Fig. X1.2) has a ground-glass 45/50 outer joint at the mouth and a 10/30 ground-glass outer joint to hold the thermometer.

NOTE X1.1—Other flasks or containers may be used. For tests requiring a larger container, a 3-L round bottom flask with a 71/60 ground-glass

outer joint can also be used. The height of the condenser (X1.2.2) and the dimensions of the trap (Fig. X1.3) can be the same as for the 1-L Erlenmeyer flask.

X1.2.2 *Condenser* (Fig. X1.4)—a modified Allihn condenser with a 45/50 ground-glass inner joint. In place of the drip tip on the conventional condenser, the exit must be formed as shown in Fig. X1.4. A smooth exit on the condenser is essential to prevent dripping. The water jacket of the condenser should be at least 250 mm long. At the top of the condenser, a 29/26 ground-glass outer joint is required to hold the trap in place.

NOTE X1.2—Dripping of condensate into hot magnesium chloride

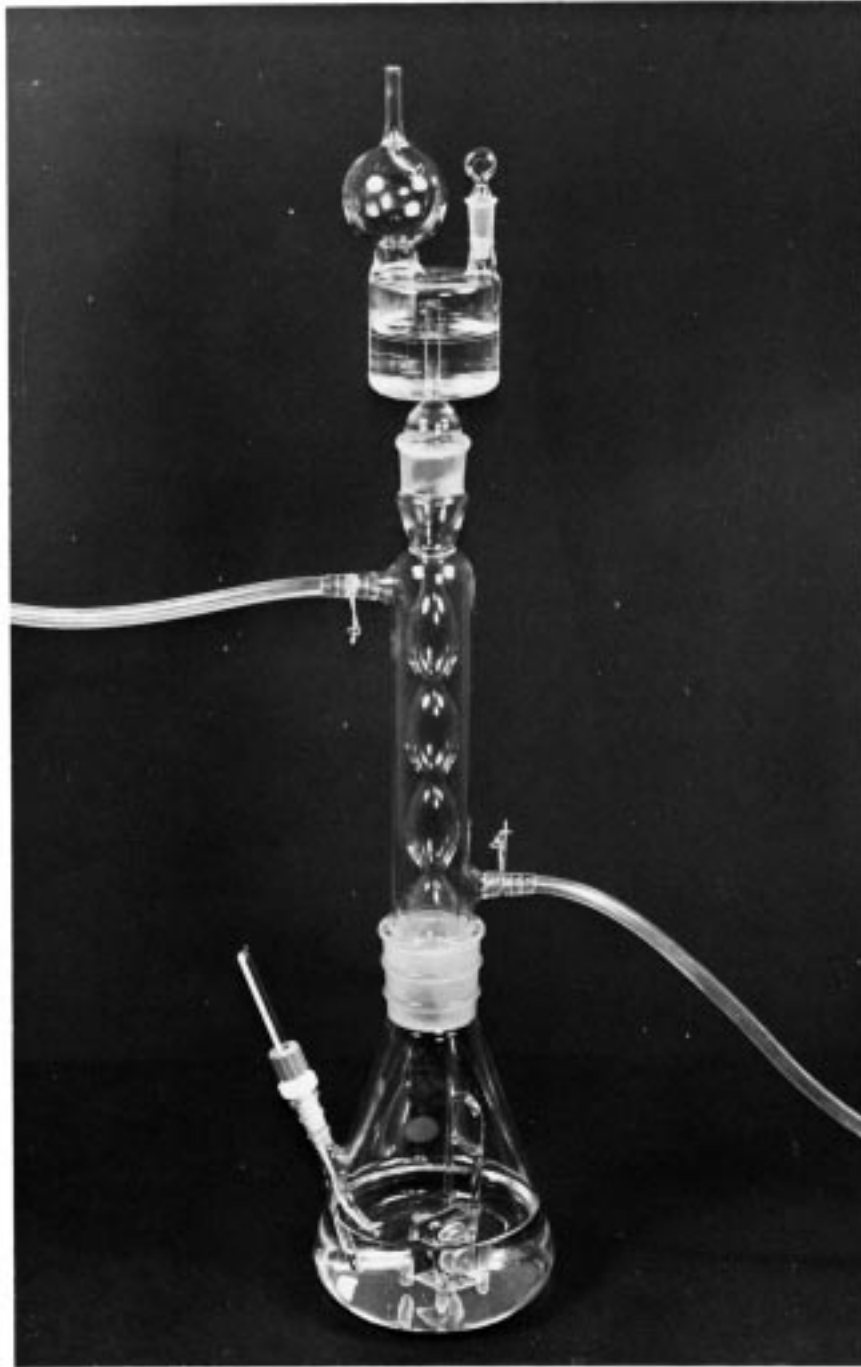

FIG. X1.1 Assembly of Glass Apparatus for Stress-Corrosion Test in Boiling Magnesium Chloride with U-Bend Specimen in Place

solution from the “drip tip” of a conventional Allihn condenser results in a pulsating generation of water vapor. These pressure waves lead to the loss of water vapor at the top of the condenser. Initially, there may be some dripping from the condenser until there is complete wetting of the walls of the flask by the condensate.

X1.2.3 Trap—containing a 25 weight percent solution of magnesium chloride (Fig. X1.3), and affixed to the top of the condenser to eliminate vapor losses by diffusion during tests in excess of 7 days. The trap is joined to the condenser by a 29/26 ground glass inner joint.

X1.2.4 Thermometer—required to adjust the boiling point,

and thereby the concentration of the magnesium chloride solution when it is prepared, and to monitor the solution temperature throughout the test. The graduations must clearly show 1°C increments in the range of 130 to 170°C (266 to 338°F). When the specially designed thermometer of Fig. X1.5 is used in the 1-L Erlenmeyer flask of Fig. X1.2, no more space is needed on hot plates than that taken up by the flasks themselves. A modified ASTM Thermometer 86D with a temperature range from 95 to 170°C (203 to 338°F) in 1°C subdivisions can also be used with this apparatus.

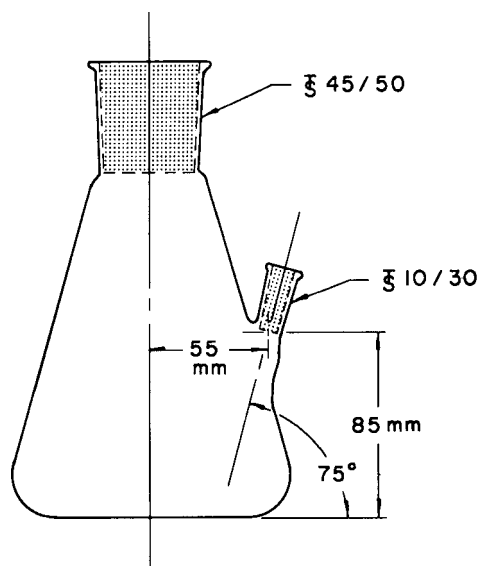

FIG. X1.2 Modified Erlenmeyer Flask (1000 mL)

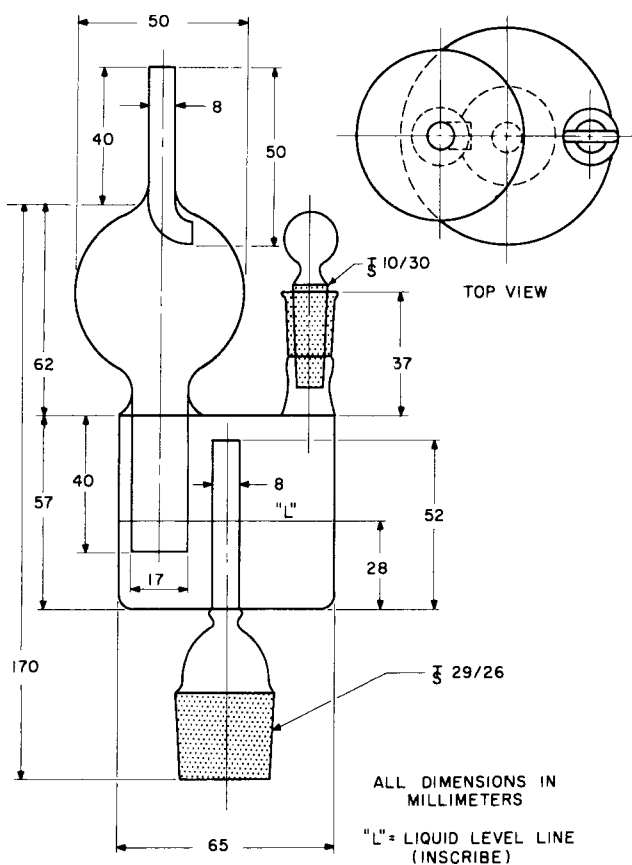

FIG. X1.3 Trap for Top of Condenser to Prevent Loss of Vapor

NOTE X1.3—The thermometer should be checked for the presence of gas bubbles before each use. These can be removed by cooling the lower part of the bulb (dry ice) and gently tapping the thermometer. Storage of a thermometer in a vertical position will prevent appearance of bubbles.

X1.2.5 *Adapter*—a fluorocarbon resin adapter containing a rubber O-ring seal for a 10/30 ground-glass outer joint must be used to hold the thermometer in place in the flask.

NOTE X1.4—Use of a thermometer with a ground-glass inner joint in

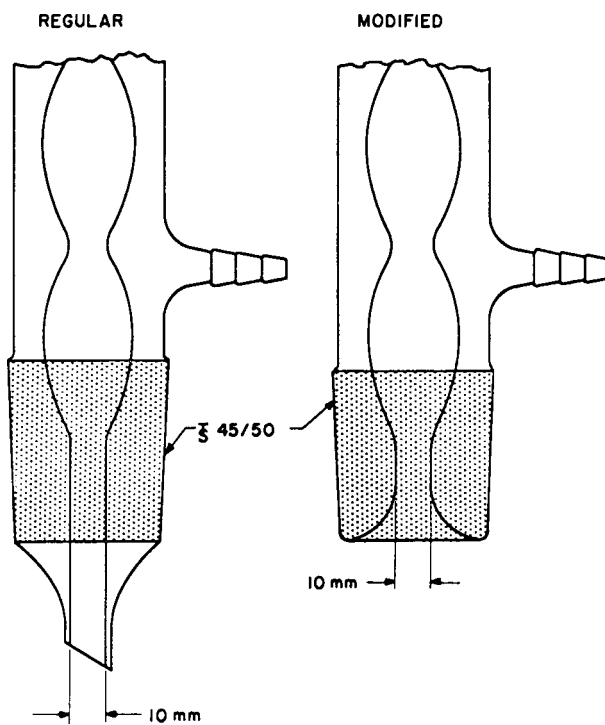

FIG. X1.4 Modification of Allihn Condenser to Prevent Loss of Vapor

place of the adapter results in appreciable loss of water vapor at this hot joint.

X1.2.6 When assembling the above components, *do not* use any lubricants on any of the ground-glass joints.

X1.3 *Assembly:*

X1.3.1 The thermometer along with its adapter is inserted into the side arm of the Erlenmeyer flask and positioned so that the bulb is located about 7.5 mm ($\frac{5}{16}$ in.) from the bottom of the flask. The adapter is tightened to prevent the loss of water during the test and the $MgCl_2 \cdot 6H_2O$, reagent water, and boiling

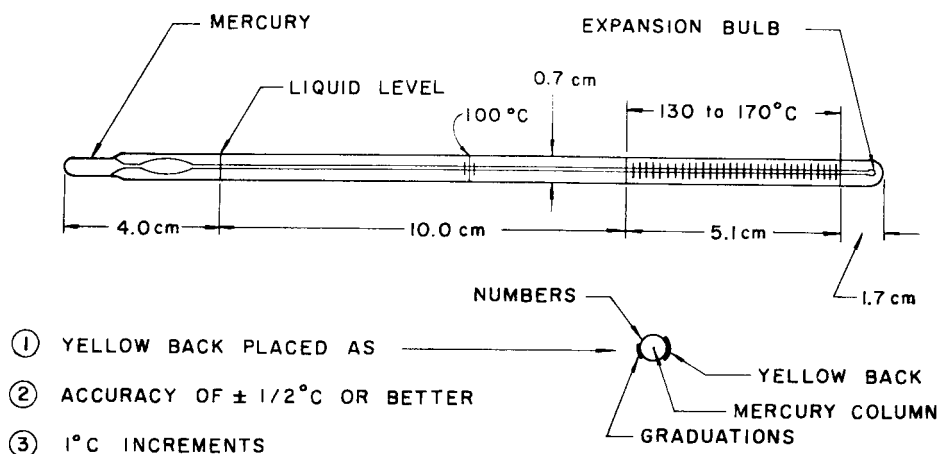

FIG. X1.5 Design of Thermometer for Use in Flask of Fig. X1.2

aids are added to the flask. After positioning the water-cooled condenser on top of the flask, the whole assembly is placed on a hot plate or other suitable source of heat. Do not attach the trap at this time.

X1.3.2 The solution concentration is adjusted by slowly adding small portions (4 to 5 mL) of reagent water until the constant boiling temperature of $155 \pm 1^\circ\text{C}$ ($311.0 \pm 1.8^\circ\text{F}$) is attained. The previously prepared test specimens and holder are now ready to be placed in the flask. This is accomplished by removing the condenser from the flask, immersing the specimen and specimen holder in the boiling solution (with caution), and quickly replacing the condenser.

X1.3.3 Cut a 50 by 450-mm (2 by 18-in.) strip of commercial aluminum foil. Wrap this foil around the outside of the joint between the condenser and the flask and press the foil against the glass so that the joint is well covered and none of the foil is in contact with the hot flask below the joint.

NOTE X1.5—The purpose of the aluminum foil is to prevent loss of condensate by evaporation where the top of the ground-glass surface of the joint is exposed to the air. Condensate rises by capillary action in the

joint and evaporates in the warm air.

X1.3.4 If the period of exposure exceeds 7 days, a liquid trap is required at the top of the condenser to maintain the constant boiling point of $155.0 \pm 1.0^\circ\text{C}$ ($311.0 \pm 1.8^\circ\text{F}$) without new additions of water to the boiling MgCl_2 solution. Fill the trap to the liquid level line with a 25% solution of MgCl_2 (see 7.4). As soon as the condensate stops dripping from the condenser and flows down the wall of the Erlenmeyer flask in a continuous stream, place the trap on top of the condenser.

NOTE X1.6—Whenever the trap is needed, it must be used with the modified condenser because the pressure pulses generated by “drip tip” condensers exceed the capacity of the trap to absorb sudden changes in pressure within the flask.

X1.3.5 During long-time tests, there may be a slow drop in the level of liquid in the trap because of evaporation of water at the top of the trap from the 25% MgCl_2 solution. This level should be brought up to the liquid level line by additions of reagent water every 7 to 14 days.

The American Society for Testing and Materials takes no position respecting the validity of any patent rights asserted in connection with any item mentioned in this standard. Users of this standard are expressly advised that determination of the validity of any such patent rights, and the risk of infringement of such rights, are entirely their own responsibility.

This standard is subject to revision at any time by the responsible technical committee and must be reviewed every five years and if not revised, either reapproved or withdrawn. Your comments are invited either for revision of this standard or for additional standards and should be addressed to ASTM Headquarters. Your comments will receive careful consideration at a meeting of the responsible technical committee, which you may attend. If you feel that your comments have not received a fair hearing you should make your views known to the ASTM Committee on Standards, at the address shown below.

This standard is copyrighted by ASTM, 100 Barr Harbor Drive, PO Box C700, West Conshohocken, PA 19428-2959, United States. Individual reprints (single or multiple copies) of this standard may be obtained by contacting ASTM at the above address or at 610-832-9585 (phone), 610-832-9555 (fax), or service@astm.org (e-mail); or through the ASTM website (www.astm.org).