



Designation: **G 4 – 9501**

Standard Guide for Conducting Corrosion-Coupon Tests in Field Applications¹

This standard is issued under the fixed designation G 4; the number immediately following the designation indicates the year of original adoption or, in the case of revision, the year of last revision. A number in parentheses indicates the year of last reapproval. A superscript epsilon (ε) indicates an editorial change since the last revision or reapproval.

1. Scope

1.1 This guide covers procedures for conducting corrosion-coupon tests in plant equipment or systems under operating conditions to evaluate the corrosive attack upon corrosion resistance of engineering materials. It does not cover electrochemical methods for determining corrosion rates.

1.1.1 While intended primarily for immersion tests, general guidelines provided can be applicable for exposure of test-coupons specimens in plant atmospheres, provided that placement and orientation of the coupons test specimens is non-restrictive to air circulation.

1.2 The values stated in SI units are to be regarded as the standard. The values given in parentheses are for information only.

1.3 *This standard does not purport to address all of the safety concerns, if any, associated with its use. It is the responsibility of the user of this standard to establish appropriate safety and health practices and determine the applicability of regulatory limitations prior to use.* See also 10.4.2.

2. Referenced Documents

2.1 ASTM Standards:

A 262 Practices for Detecting Susceptibility to Intergranular Attack in Austenitic Stainless Steels²

¹ This guide is under the jurisdiction of ASTM Committee G-1 G01 on Corrosion of Metals and is the direct responsibility of Subcommittee G01.12 on In-Plant Corrosion Tests.

Current edition approved Jan. 15, 1995; Oct. 10, 2001. Published March 1995; December 2001. Originally issued as A224-39. Last previous edition G4-84, G4-95.

E 3 Practice for Preparation of Metallographic Specimens³

G 1 Practice for Preparing, Cleaning, and Evaluating Corrosion Test Specimens⁴

G 15 Terminology Relating to Corrosion and Corrosion Testing⁴

G 16 Guide for Applying Statistics to Analysis of Corrosion Data⁴

G 30 Practice for Making and Using U-Bend Stress Corrosion Test Specimens⁴

~~G 36 Practice for Performing Evaluating Stress-Corrosion-Cracking-T Resistance of Metals and Alloys in a Boiling Magnesium Chloride Solution~~⁴

~~G 37 Practice for Use of Mattsson's Solution of pH 7.2 to Evaluate the Stress-Corrosion Cracking Susceptibility of Copper-Zinc Alloys~~⁴

G 41 Practice for Determining Cracking Susceptibility of Metals Exposed Under Stress to a Hot Salt Environment⁴

~~G 44 Practice for Evaluating Stress Corrosion Cracking Resistance Exposure of Metals and Alloys by Alternate Immersion in Neutral 3.5 % Sodium Chloride Solution~~⁴

~~G 46 Practice 46 Guide~~ for Examination and Evaluation of Pitting Corrosion⁴

G 47 Test Method for Determining Susceptibility to Stress-Corrosion Cracking of ~~High-Strength~~ 2XXX and 7XXX Aluminum Alloy Products⁴

G 58 Practice for Preparation of Stress-Corrosion Test Specimens for Weldments⁴

G 78 Guide for Crevice Corrosion Testing of Iron-Base and Nickel-Base Stainless Alloys in Seawater and Other Chloride-Containing Aqueous Environments⁴

3. Significance and Use ⁵

3.1 Observations and data derived from ~~coupon~~ corrosion testing are used to determine the average rate of corrosion and/or other types of attack (see Terminology G 15) that occur during the exposure interval. The data may be used as part of an evaluation of ~~potential candidate~~ materials of construction for use in similar service or for replacement materials in existing facilities.

3.2 The data developed from ~~this guide~~ in-plant tests may also be used as guide lines to the behavior of existing plant materials for the purpose of scheduling maintenance and repairs.

3.3 Corrosion rate data derived from a single exposure generally do not provide information on corrosion rate change versus time. Corrosion rates may increase, decrease, or remain constant, depending on the nature of the corrosion products and the effects of incubation time required at the onset of pitting or crevice corrosion.

4. Limitations

4.1 Metal specimens immersed in a specific liquid may not corrode at the same rate or in the same manner as in equipment in which the metal acts as a heat transfer medium in heating or cooling the liquid. In certain services, the corrosion of heat-exchanger tubes may be quite different from that of the shell or heads. This phenomenon also occurs on specimens exposed in gas streams from which water or other corrodents condense on cool surfaces. Such factors must be considered in both design and interpretation of plant tests.

4.2 Effects caused by high velocity, abrasive ingredients, etc. (which may be emphasized in pipe elbows, pumps, etc.) may not be easily reproduced in ~~coupon~~ simple corrosion tests.

4.3 The behavior of certain metals and alloys may be profoundly influenced by the presence of dissolved oxygen. It is essential that the test ~~coupons~~ specimens be placed in locations representative of the degree of aeration normally encountered in the process.

4.4 Corrosion products from the test specimens may have undesirable effects on the process stream and should be evaluated before the test.

4.5 Corrosion products from the plant equipment may influence the corrosion of one or more of the test metals. For example, when aluminum specimens are exposed in copper-containing systems, corroding copper will exert an adverse effect on the corrosion of the aluminum. On the contrary, stainless steel specimens may have their corrosion resistance enhanced by the presence of the oxidizing cupric ions.

4.6 The accumulation of corrosion products can sometimes have harmful effects. For example, copper corroding in intermediate strengths of sulfuric acid will have its corrosion rate increased as the cupric ion concentration in the acid increases.

~~4.7 Coupon corrosion testing is~~

4.7 Tests covered by this guide are predominantly designed to investigate general corrosion; however, other forms of corrosion may be ~~evaluated with coupons.~~ evaluated.

4.7.1 Galvanic corrosion may be investigated by special devices that couple one ~~coupon~~ specimen to another in electrical contact. It should be observed, however, that galvanic corrosion can be greatly affected by the area ratios of the respective metals.

4.7.2 Crevice or concentration cell corrosion may occur when the metal surface is partially blocked from the bulk liquid, as under a spacer. An accumulation of bulky corrosion products between ~~coupons~~ specimens can promote localized corrosion of some

² Annual Book of ASTM Standards, Vol 01.03.

³ Annual Book of ASTM Standards, Vol 03.01.

⁴ Annual Book of ASTM Standards, Vol 03.02.

⁵ This guide is consistent with NACE document RP0497, Standard Recommended Practice "Field Corrosion Evaluation Using Metallic Test Specimens".

alloys or affect the general corrosion rates of others. Such accumulation should be reported.

4.7.3 Selective corrosion at the grain boundaries (for example, intergranular corrosion of sensitized austenitic stainless steels) will not be readily observable in mass loss measurements and often requires microscopic examination of the ~~coupons~~ specimens after exposure.

4.7.4 Parting or dealloying is a condition in which one constituent is selectively removed from an alloy, as in the dezincification of brass or the graphitic corrosion of cast iron. Close attention and a more sophisticated evaluation than a simple mass loss measurement are required to detect this phenomenon.

4.7.5 Pitting corrosion cannot be evaluated by mass loss. It is possible to miss the phenomenon altogether when using small test specimens since the occurrence of pitting is often a statistical phenomenon and its incidence can be directly related to the area of metal exposed.

4.7.6 Stress-corrosion cracking (SCC) may occur under conditions of tensile stress and it may or may not be visible to the naked eye or on casual inspection. A metallographic examination (Practice E 3) will confirm this mechanism of attack. SCC usually occurs with no significant loss in mass of the ~~test-coupon, specimen,~~ specimen, except in some refractory metals.

4.7.7 A number of reactive metals, most notably titanium and zirconium, develop strongly adherent corrosion product films in corrosive environments. In many cases, there is no acceptable method to remove the film without removing significant uncorroded metal. In these cases, the extent of corrosion can best be measured as a mass gain rather than mass loss.

4.7.8 Some materials may suffer accelerated corrosion at liquid to atmospheric transition zones. The use of small test specimens may not adequately cover this region.

5. ~~Test-Coupon~~ Specimen Design

5.1 Before the size, shape, and finish of ~~test-coupons~~ specimens are specified, the objectives of the test program should be determined, taking into consideration any restrictions that might dictate fabrication requirements. The duration, cost, confidence level, and expected results affect the choice of the shape, finish, and cost of the ~~coupons-specimen.~~

5.1.1 ~~Test-coupons~~ specimens are generally fabricated into disks or rectangular shapes. Other shapes such as balls, cylinders, and tubes are used, but to a much lesser extent.

5.1.2 Disks are normally made by one of three methods: (1) by punching from sheet material, (2) by slicing from a bar, or (3) by trepanning by a lathe or mill. Punched disks are by far the least expensive and should be considered if material thickness is not a limitation. Some of the positive characteristics of disks are: (1) the surface area can be minimized where there is restricted space, such as in pipeline applications, (2) disks can be made inexpensively if a polished or machined surface finish is not required, and (3) edge effects are minimized for a given total surface area. Some negative characteristics are: (1) disks are very costly to fabricate if a ground finish and machined edges are required, (2) disks fabricated from sheet material result in a considerable amount of scrap material, and (3) disks sliced from a bar present a surface orientation that can result in extensive end-grain attack. Using a bar is undesirable unless end-grain effects are to be evaluated.

5.2 Rectangular ~~coupons~~ specimens are fabricated by either punching, shearing, or saw cutting. Punched ~~coupons~~ disk shaped specimens are the most economical if the quantity is sufficiently high to justify the initial die cost. Fabrication is more cost-effective for rectangular ~~coupons~~ specimens than for disks when ground finished and machined sides are required, and they can be made using very few shop tools. In some cases, rectangular ~~coupons~~ specimens are more awkward to mount.

5.3 Material availability and machinability also affect the cost of producing all types of ~~coupons-specimens.~~ Before the shape and size are specified, the corrosion engineer should determine the characteristics of the proposed materials.

6. Test Specimens

6.1 The size and shape of test specimens are influenced by several factors and cannot be rigidly defined. Sufficient thickness should be employed to minimize the possibility of perforation of the specimen during the test exposure. The size of the specimen should be as large as can be conveniently handled, the limitation being imposed by the capacity of the available analytical balance and by the problem of effecting entry into operating equipment.

6.2 A convenient size for a standard corrosion ~~coupon~~ disk shaped specimen is 38 mm (1.5 in.) in diameter and 3 mm (0.125 in.) in thickness with an 11 mm (0.438 in.) hole in the center of the ~~round-coupon, specimen.~~ This size was arrived at as being the maximum size that could easily effect entry through a normal 38 mm nozzle. However, it is also convenient for larger size nozzle entries as well as for laboratory corrosion testing. A convenient standard ~~coupon~~ specimen for spool-type racks measures 25 by 50 by 3 mm (1 by 2 by 0.125 in.) or 50 by 50 by 3 mm (2 by 2 by 0.125 in.). A round ~~coupon~~ specimen of 53 by 3 mm (2 by 0.125 in.) or 55 by 1.5 mm (2 by 0.062 in.) is sometimes employed. These last three measure about 0.005 dm² in surface area.

6.3 Other sizes, shapes, and thicknesses of specimens can be used for special purposes or to comply with the design of a special type of corrosion rack. Special ~~coupons~~ designs should be reduced to a few in number in preliminary tests; special ~~coupons~~ designs should be employed to consider the effect of such factors of equipment construction and assembly as heat treatment, welding, soldering, and cold-working or other mechanical stressing.

6.4 Since welding is a principal method of fabricating equipment, welded ~~coupons~~ specimens should be included as much as possible in the test programs.

6.4.1 Aside from the effects of residual stresses, the main items of interest in a welded ~~coupon~~ specimen are the corrosion

resistance of the weld bead and the heat affected zone. Galvanic effects between weld metal and base metal can also be evaluated. The weld and heat affected zone regions are relatively small; therefore, welded ~~coupons~~ specimens should be made slightly larger than the normal size ~~coupon~~ non-welded specimens when possible, for example, 50 mm by 75 mm (2 in. by 3 in.). The optimum method of welding ~~coupons~~ corrosion test specimens is to join the two halves using a single vee or double vee groove with full penetration and multiple passes. Double vee joint preparation is used for very thick samples. Machining the weld flush is optional, depending on how closely the sample will be examined afterward (see practice G58).

6.4.2 The welding process and number of passes influence the heat input and, consequently, the width and location of the heat affected zone. For example, gas tungsten arc welding has lower heat input than oxygen fuel welding and causes a narrower heat affected zone, which is also closer to the weld bead.

7. Preparation of Test Specimens

7.1 Controversy exists as to whether the test ~~coupon~~ specimen edges should be machined. The cold-worked area caused by shearing or punching ~~coupons~~ operations can provide valuable information on alloy susceptibility to stress corrosion cracking. Also, the ability to compare information among ~~coupons~~ specimens of different materials can be affected by the amount of cold work performed on the material. Therefore, the decision to machine ~~test coupons~~ and to test ~~coupons~~ specimens with/without the residual stresses associated with cold work should be made on a case-to-case basis.

7.1.1 The depth of cold work associated with punching and shearing operations typically extends back from the cut edge to a distance equal to the ~~coupon~~ specimen thickness. Removal of the cold worked areas can be performed by grinding or careful machining the ~~coupon~~ specimen edges.

7.1.2 Ideally, the surface finish of the ~~test coupon~~ specimen should be identical with replicate that of the surface finish of the material to be used for equipment fabrication. However, this is often difficult because the finish on materials varies between mills, between sheet and plate and even between heat treatments. The mill scale and the amount of oxides on the surface can vary as well. Also, surface finishes are difficult to apply to edges that have been distorted by punching or shearing. Since the primary requirement is usually to determine the corrosion resistance of the material itself, a clean metal surface is most often used. The purpose of the test dictates the required finish of the ~~coupon~~ specimen. For instance, for water treating applications, relative changes of weights of ~~coupons~~ specimens are usually compared to optimize inhibitor additions. The ~~coupon~~ specimens are generally punched or sheared and finished by blasts with glass beads. This is one of the most economical ways of preparing corrosion test specimens. Manufacturing variables in ~~coupon~~ specimen preparation that can be removed reasonably should be eliminated. A standard surface finish facilitates the comparison of results among test samples.

7.2 Some of the available finishes are:

7.2.1 Mill finish (pickled, bright annealed, or shot blasted),

7.2.2 Electrolytic polished, (Note that electrolytic polishing can produce a surface layer enriched in some alloying elements while depleted in others. For example, chromium is enriched on stainless surfaces and sulfur is depleted.)

7.2.3 Blasted with sand or steel shot, (Note that blasting many metals with sand can cause embedded sand particles and steel shot can cause surface contamination with iron or iron oxide. Glass beads are better, but not if broken pieces are allowed to be used in the blasting.)

7.2.4 Sanded with abrasive cloth or paper, for example, SiC,

7.2.5 Machine finished, and

7.2.6 Passivation of stainless steel with nitric acid to remove surface iron contamination and other chemical cleaning methods used, for example, after welding.

7.3 The surface finish most widely used is produced by sanding with an abrasive cloth or paper. Sanding removes the mill scale and oxides as well as other defects in the material such as scratches, pits, etc., that ~~can~~ could produce misleading results when the data are being analyzed.

7.3.1 A 120 grit finish is generally acceptable and is readily produced without the need for specialized equipment. Other surface finishes may be obtained through the appropriate use of abrasive papers and cloth. In order to prevent metallurgical changes that could affect the corrosion resistance, the test sample should be cooled during fabrication. Wet sanding is one method of preventing specimens from heating up. In many cases, it is necessary to begin sanding with coarse abrasives and progressively move to finer abrasives.

7.3.2 Clean polishing belts should be used to avoid contamination of the metal surface, particularly when widely dissimilar metals are being finished. For example, a belt used to sand brass should not be used to sand aluminum. Particles of one metal could become imbedded in the other, resulting in erroneous data.

7.4 Test specimens should be cleaned and the initial mass determined (see Practice G 1).

7.5 A pre-exposure inspection of test specimens should be conducted in order to identify any pits, mechanical scratches, or residual surface treatment artifacts that could influence the corrosion behavior of the specimen.

8. Number of Test Specimens

8.1 In general, at least duplicate specimens should be tested. If possible, in cases in which confidence limits are required for corrosion rate measurement, then somewhere between 5 and 10 replicates should be run, depending on the scope of the program. The confidence level can be established by the procedures shown in Guide G 16. The duplicate samples should be widely separated

on the test rack rather than adjacent to one another. The results for the samples should also be reported separately.

9. Identification of Test Specimens

9.1 Although it may be necessary in special instances to notch the edge of the specimens for identification, it is preferable that they be stamped with a code number. The stamped number has an additional advantage in that, should a specimen show a preferential attack at the stamped area, a warning is given that the material is susceptible to corrosion when cold worked. It is also possible in some instances to detect stress-corrosion cracking emanating from the stamped areas. Note, however, that although the presence of such localized attacks is a positive indication, absence of attack is not a guarantee of immunity from attack in operating equipment.

9.1.1 A map sheet identifying the location of the test specimens on the test rack described below is useful.

10. Test Rack Design and Test Location

10.1 The purpose of the rack is to support ~~test-coupons~~ specimens in the process environment at the proper location and orientation. To accomplish this, the corrosion engineer should first determine the number, size, and spacing of the ~~coupons~~ specimens to be tested and then establish the proper location and orientation of the rack. With this accomplished, the type of rack can be selected.

10.1.1 ~~Coupons~~

10.1.1 Specimens are usually electrically isolated from one another and the rack unless special effects, such as galvanic corrosion, are under study. Insulation is achieved by sleeving all metal parts in contact with the ~~coupons~~ specimens and separating the ~~coupons~~ them with washers. The sleeves and washers should be made from a nonconductive material such as polytetrafluoroethylene (PTFE) fluorocarbon or ceramic material.

10.2 The rack should be as simple as possible, but it also should be sturdy and constructed of materials resistant to the test environment. Bolts should be spot welded or double nuts used to prevent loosening during exposure. Occasionally an insulated bolt is all that is necessary to suspend the test specimens. Handling this assembly requires a few more precautions than some other mounting systems but is cost effective in many instances. Another method is to suspend the ~~test-coupons~~ specimens by an insulated wire. This system can be used in a storage tank or other nonagitated vessels; for example, as used in chemical cleaning operations.

10.2.1 A flat bar rack is usually made of rigid material, such as 6 mm (.0250 in.) thick plate, and is approximately 25 mm (1 in.) wide by 305 mm (12 in.) long. With a few mounting holes at one end, a flat bar rack is capable of supporting several specimens. The other end is attached in the process location either by welding, bolting, or clamping. See Fig. 1.

10.2.2 ~~A spool rack, with adjustable end plates, can be used to mount up to 36 coupons. Typical~~

10.2.2 Typical racks are approximately 305 mm (12 in.) long with 15 mm (0.625 in.) spacing between specimens. A spool rack, with adjustable plates, can be used to mount up to 36 specimens. With the support bars on the sides, the rack can be handled without touching the ~~coupons~~ specimens. The rack can be easily mounted by strips that are attached to the top and bottom. These strips can be welded, bolted, or clamped in place. See Fig. 2.

10.2.3 A pipeline rack is designed to fit between the flanges in a pipeline. It can also be used at a nozzle. Because of the cantilever support and pipe diameter, the number of ~~coupons~~ specimens that can be mounted on this system is restricted. Design modification can be made in order to increase the number of ~~coupons~~ specimens. A potential problem with the pipeline rack is the flow restriction in the pipeline. See Fig. 3.

10.3 One of the most common reasons for the failure of test racks is selecting fasteners that do not resist the environment. Since the bolting hardware is usually highly stressed and contains crevices, corrosive attack on fasteners can occur rapidly. Another common reason for failure is defective welding of the test rack components or of the test rack to the vessel. Full-penetration welds should be used, and the area to be welded should be thoroughly cleaned. Fatigue failures caused by equipment vibration or high flow rates is another leading cause of rack failures. With proper design, a rack can be built that will eliminate these failures.

10.3.1 Problems caused by failure of a mounting system also should be considered in designing the test rack. In many cases, such as with agitated vessels, pumps, etc., a loose test rack could do extensive damage. (Test racks should be inserted after the pumps to prevent damage to the impeller in case of rack failure.)

10.4 Retractable ~~coupon~~ specimen holders overcome the greatest limitation of most forms of ~~coupon~~ in-plant testing, which is the need to shut down in order to remove the test rack from the process. The arrangement consists of a 50 mm (2 in.) or larger

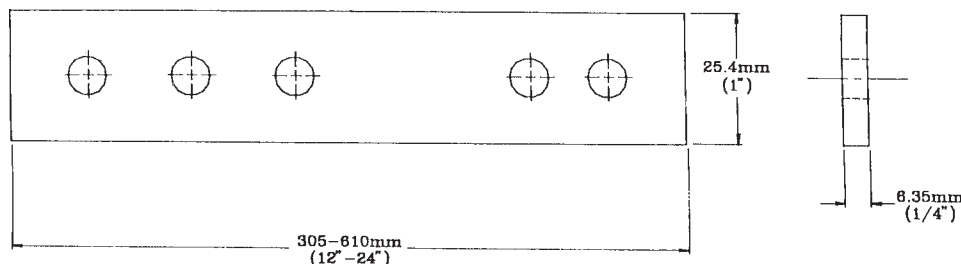

FIG. 1 Flat Bar Rack

MATERIAL: Any Material
Resistant To Corrosive Environment.

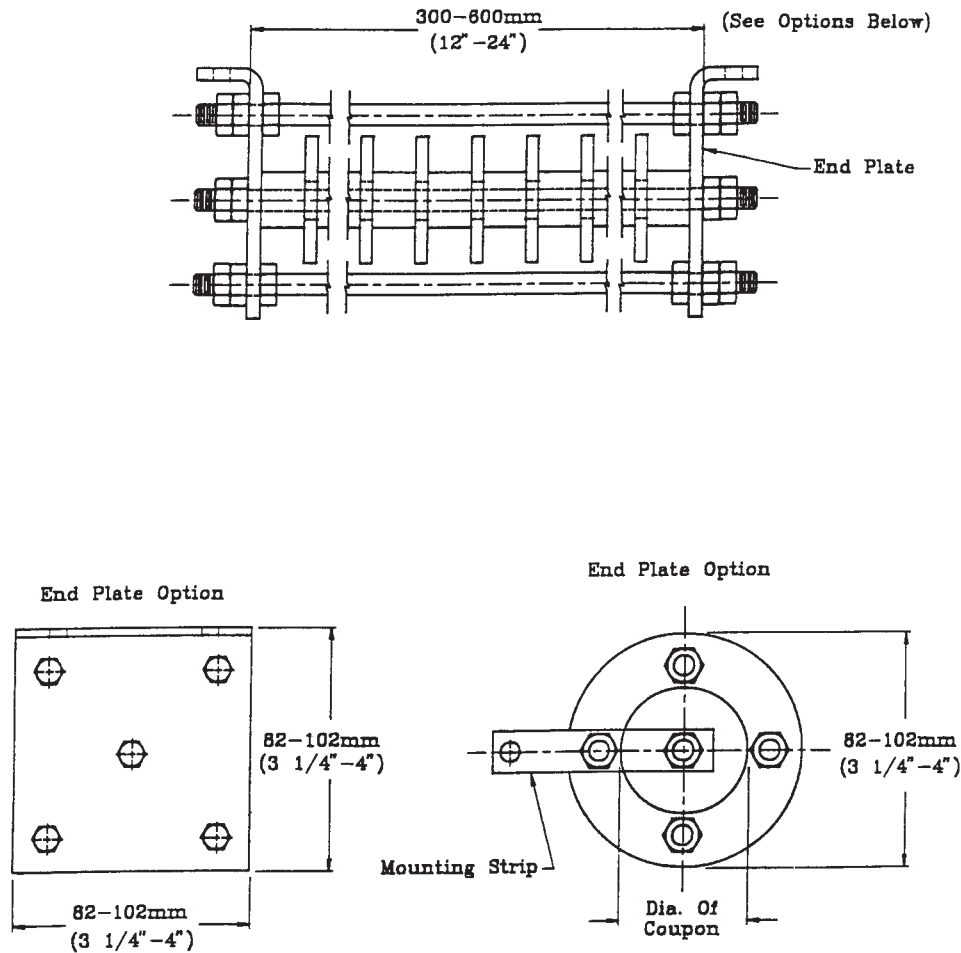

FIG. 2 Typical Spool Rack

nozzle that is fitted with a fully opening gate or plug valve. The rod-shaped coupon specimen holder is contained in a retraction chamber, which is flanged to the valve, and is fitted additionally with a drain valve (see Fig. 3). The other end of the retraction chamber contains a packing gland through which the coupon specimen holder passes. The test coupons specimens are mounted on the rod in the extended position and are then drawn into the retraction chamber. The chamber is bolted to the gate or plug valve, which is then opened up to allow the coupons specimens to be moved into the operating environment. The sequence is reversed to remove the coupons specimens and the process is cleared from the retraction chamber before disconnecting it to access the coupons. See specimens, see Fig. 4.

10.4.1 All components of retractable coupon specimen holders must be suitably corrosion resistant and fabricated to standards that comply with the equipment design code. The consequences of a process leak must be carefully considered. Retractable coupon specimen holders are best considered in low pressure systems, that is, 1 MPa (about 150 psi) or less. However, commercially available probes and retrieval tools are available for service in systems up to 20 MPa (3000 psi).

NOTE 1—**Caution:** In using retractable coupon specimen holders on-line with either hot, pressurized fluids or hazardous fluids, or both, the possibility of a serious leak (or blowout) at the packing gland must be considered and appropriate precautions taken. Provisions should be made to purge and dispose of the process fluid from the cavity where the specimens are held before they are removed from the system. Restraining devices must be used when removing specimens while the internal system is pressurized.

10.5 Selection of the process location is critical to obtaining meaningful data. The three basic process locations are (see Fig. 4): (1) immersed stagnant, for example, the boot of the filter where deaerated conditions, solid settlements prevail, (2) immersed flowing, for example, in piping where aeration, gas and solids entrainment, and turbulence or velocity exert effects, (3) splash, waterline, or liquid level where the conditions simulate partial immersion or spray. When calculating corrosion rates, the test time is not reduced to compensate for partial immersion conditions.

10.6 In certain situations, process conditions (in addition to the three basic locations) must be considered. For example:

10.6.1 Velocity effects should be considered if the coupons specimens are laid out flat and parallel to the flow. If the coupons

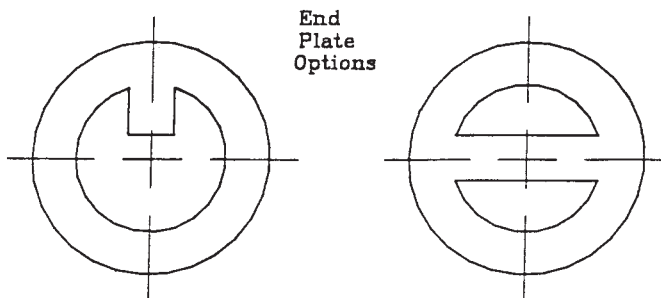
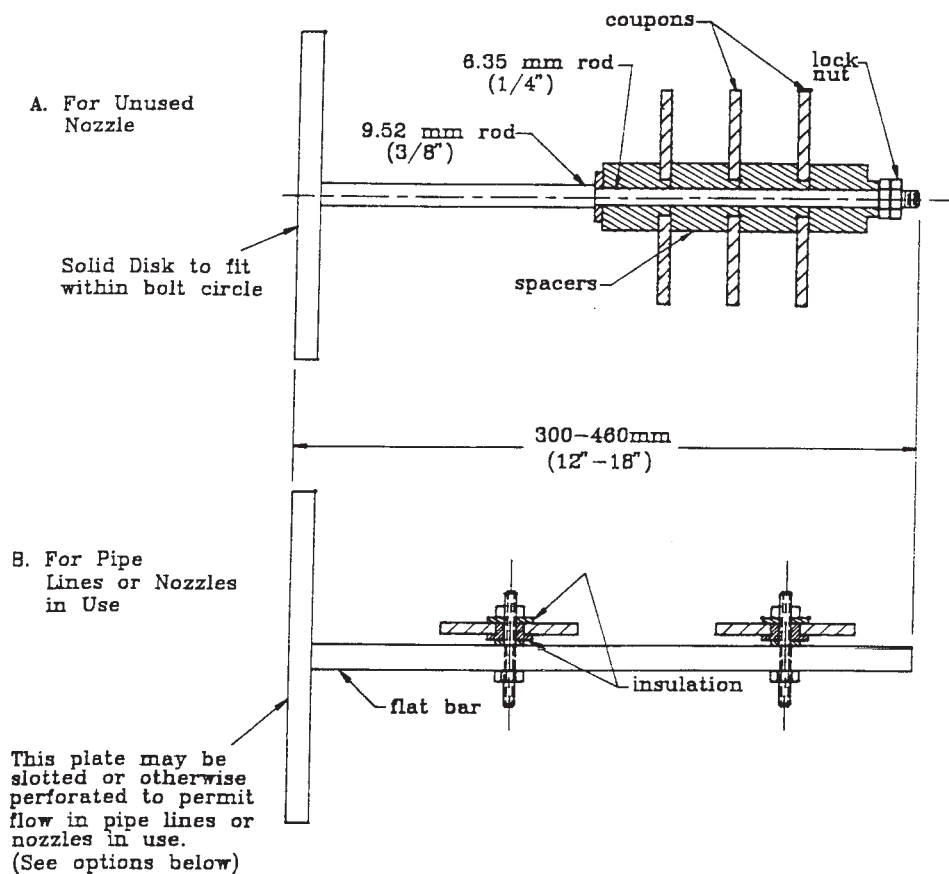

FIG. 3 Pipe Insertion Rack

specimens are arranged any other way, they tend to shield one another from the turbulence. The location of the coupons specimens is critical in simulating the turbulence experienced, for example, at a pipe wall.

10.6.2 Condensation (dew point or *cold finger*) effects should be considered. The coupons test specimens represent a different mass effect from a pipe, vessel wall, tube sheet, tube, etc. It may be necessary to expose several sets of coupons specimens in a line to determine the optimum condition that duplicates condensation in the equipment.

10.6.3 The effects of heat transfer (for example, when the tube wall is heated) are impossible to duplicate with conventional coupons specimens.

11. Selection of Materials for Evaluation

11.1 The following materials, at least, should be considered for inclusion as controls:

11.1.1 The material currently used in the process equipment in which the test is being run or in the equipment of interest.

11.1.2 A material that would be expected to incur the type of corrosion of immediate concern, for example, stress corrosion, cracking, pitting, crevice corrosion, and

11.1.3 One or more materials likely to be resistant to the environment.

12. Initial Coupon Specimen Measurements

12.1 After the coupon specimen has been cut to size and the final surface finish applied (if other than mill finish), it should be

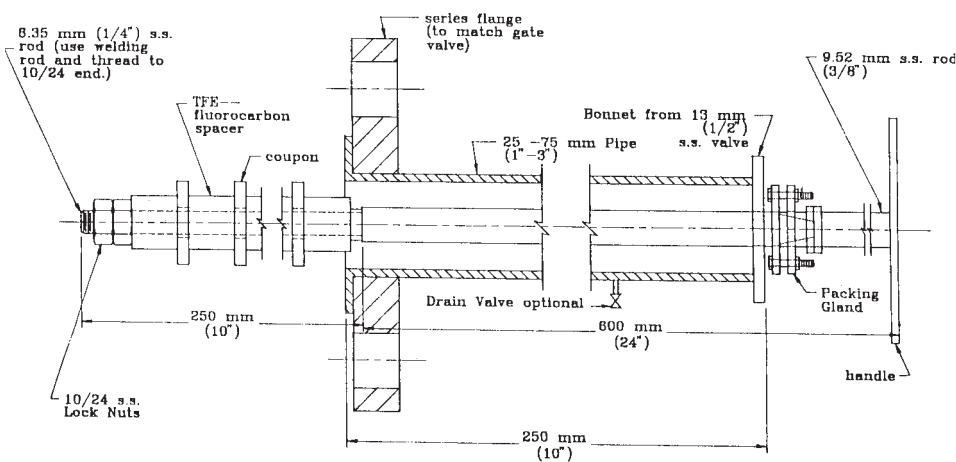

MATERIAL: Any Material Resistant to Corrosive Environment.

FIG. 4 Retractable "Slip-In" Cou Specimen Holder

cleaned in an organic solvent and the mass determined to the nearest 0.1 mg on an analytical balance. The total surface area is also determined to an accuracy of $\pm 1\%$. These measurements are filed for later use in the corrosion rate calculations.

12.2 During fabrication, each coupon specimen should be stamped with a code number for identification. The record of the details of the test exposure (dimensions, weight, location, method of mounting, location on rack, etc.) should be kept in a permanent, bound log book. Responsibility for properly maintaining the records in this log book throughout the test should be specifically assigned to one individual.

12.3 For coupons specimens of materials that cannot be stamped (for example, too hard or brittle), a system of notches can be used to identify individual coupons specimens. Notches may be formed by filing or grinding.

13. Installation of Specimen Holder

13.1 The location of the test specimens in the operating equipment will be governed by the information that is desired. This may require tests at more than one location in the same piece of equipment, such as below the level of the test liquid, at the level of the liquid, or in the vapor phase.

13.2 It is desirable to have the specimen holder securely fixed in place. The preferred position of the holder is with the long axis horizontal so as to prevent drippage of corrosion products from one specimen to the other. Preferably, the specimen should be so placed that any flow of liquid will be against the edges of the specimens. The same condition of agitation of the liquid should then be encountered by all specimens.

14. Duration of Exposure

14.1 The duration of exposure may be based on known rates of deterioration of the materials in use. More often, it is governed by the convenience with which plant operations may be interrupted to introduce and remove test specimens. In many tests, some materials may show little or no attack while other materials may be completely destroyed. In general, the duration of the test should be as long as possible, commensurate with the resistance of the materials under test. In special cases, the duration may be established in regard to some specific phase of the operation, for example, to study corrosion in one step of a batch process. Possible changes in the rate of corrosion may be studied either by successive exposures or by the installation of several sets of specimens at the same time, which can be removed one set at a time at different intervals. The minimum duration of the test in hours is approximately 50, divided by the expected corrosion rate expressed in millimetres per year (or 2000 divided by the corrosion rate in mils per year). It is desirable to run the test with various time intervals so that the changes in corrosion rate with exposure time can be evaluated.

15. Removal of Specimens from Test

15.1 The condition and appearance of the holder and specimens after removal from equipment should be noted and recorded. In removing the specimens from the holder, exercise care to keep them in proper sequence relative to each other so that any specimen may be identified from the original record of its position on the holder. That is important if corrosion has been so severe that identification marks have been removed.

15.2 A record should be made of the appearance and adhesion of any coatings or films on the surface of the specimens after washing. It may be desirable to photograph the specimens. Color photographs may be of value. Samples of any products or films resulting from corrosion may be preserved for future study.

16. Cleaning and Weighing of Test Specimens

16.1 Specimens should be cleaned as soon as possible after removal from test.

16.2 The procedures for cleaning and weighing specimens are described in Practice G 1.

17. Examination of Specimen Surface

17.1 The specimen should be carefully examined using low-power magnification as needed for type and uniformity of surface attack such as etching, pitting, dealloying or parting, tarnishing, filming, scaling, etc. If pitting is observed, the number, size and distribution, and the general shape and uniformity of the pits should be noted (see Practice Guide G 46). The maximum and minimum depth of the pits can be measured with a calibrated microscope or by the use of the depth gage. Photographs of the cleaned specimens will serve as an excellent record of the surface appearance.

17.2 Detection of certain effects, such as stress corrosion cracking, dealloying, or intergranular attack, will require low-power microscopic examination. However, in some cases, higher resolution and magnification examinations may be necessary. This could include, but is not limited to, scanning electron microscopy or high-power optical microscopy, or both, of metallographically prepared specimens. Mass loss is often used to evaluate intergranular corrosion (see Practices A 262).

17.3 A distinction should be made between localized corrosion occurring under the insulating spacers and occurring on the boldly exposed surface. As previously noted, corrosion at or under the insulating spacers is an indication of susceptibility of the material to crevice corrosion (see Guide G 78) in the specific environment. Pitting on the surface is indicative of the pitting tendency of the environment on the boldly exposed surfaces of the specific alloy and specimens to be evaluated.

17.4 In the case of pitting of the specimen, the mass loss is of little value and the study of the number, size, and distribution of the pits will be of much more importance. Sometimes pitting is initiated but is self-healing and stops. (Additional information is provided in Practice Guide G 46.)

17.5 If an alloy is known to be susceptible to localized corrosion on a microscale, such as the phenomenon of intergranular corrosion in stainless steel, dezincification in brass, or stress-corrosion cracking of any kind, the specimen should be bent after the previously outlined examination is completed, and any cracks that develop on the surface noted. Use caution when bending materials susceptible to hydrogen embrittlement. The results should be compared with those obtained on similar bend tests on unexposed specimens from the same lot of material. Metallographic examination (Practice E 3) is also a useful means of characterizing these phenomena.

17.6 The behavior of the coupons individual specimens in galvanic couples can be compared with that of corresponding insulated specimens exposed at the same time, and any galvanic effects can be observed. In a galvanic couple, the corrosion on one coupon specimen will be accelerated while the other will be decelerated. As mentioned earlier, such tests are only qualitative, as the extent of the galvanic corrosion is influenced by the area ratio between the anodic and cathodic members of the galvanic couple, the relative potential difference between the dissimilar metals, and the solution conductivity. The results will apply directly only to assemblies in which the ratio of areas used in making the tests is similar to the ratio of areas anticipated in the fabricated assembly.

18. Localized Corrosion

18.1 Metals often perform differently in aerated versus nonaerated environments, depending on how strongly oxygen reduction (cathodic depolarization) controls the cathodic reaction. The presence of other oxidizers, such as ferric or cupric ions, also can have an effect. Other factors that can affect crevice corrosion behavior include, for example, crevice former material and size, the resulting gap produced by tightening, and the area ratio of the shield to exposed surfaces. Some variables influence the initiation of attack while others may impact both initiation and propagation. In process equipment containing crevices, such as under gaskets or scale deposits, variable corrosion behavior may occur.

18.2 Several types of crevice corrosion spacers can be substituted for the normal flat washer to study crevice corrosion in more detail (see Guide G 78). Coupons Test specimens should be photographed to document the location and overall affected area of crevice attack. Although the presence of crevice corrosion on test coupons specimens is a positive indication, its absence does not guarantee the immunity of equipment to failure.

18.3 Pitting can occur on an unshielded metal surface and can lead to failure of equipment displaying a low general corrosion rate. Pitting can occur in passive type materials such as some grades of aluminum and stainless steel; it may also affect some copper base and nickel base alloys. The environment usually contains an aggressive ion, such as chloride, which is made more aggressive if the conditions are oxidizing. Pitting can occur on usually nonpassive metals, such as steel, if, for example, a filming inhibitor breaks down locally.

18.3.1 Pitting test data should include a measurement of the maximum pit depth during the test period and it should encompass a description of the following characteristics of the pit: (1) shape—jagged, circular, elongated, (2) section—shallow, deep, rounded, conical, undercut, and (3) amount—superficial, scattered, profuse, isolated.

18.4 Guidelines for evaluating pitting are contained in Practice Guide G 46. The statistical nature of pitting indicates that it is more likely to occur within large coupons specimens and is dependent on the surface finish of the test coupon specimen. Therefore, evaluation of pitting must use the largest practical size coupon specimen and a standardized surface finish and preparation technique.

18.5 Properly conceived laboratory tests (see, for example, Practices G 30, G 36, G 37, G 41, G 44, and Test Method G 47, etc.) are valuable tools for investigating factors affecting stress corrosion cracking of engineering alloys. However, in-plant corrosion tests for stress corrosion cracking susceptibility come closer to representing the environmental variables that could affect alloy

behavior in service. The limitations of both laboratory tests and in-plant corrosion should be recognized. For example, simple exposure of stressed specimens in an operating flow stream may not take heat transfer, if present in service, into account.

19. Report

19.1 In reporting results of corrosion tests, the conditions of the test should be described in complete detail with special attention being given to the following:

- 19.1.1 Corrosive medium and concentration,
- 19.1.2 Type of equipment in which test was made,
- 19.1.3 Process carried out in the operating equipment,
- 19.1.4 Location and configuration of specimens in the operating equipment,
- 19.1.5 Temperature of corrosive media (maximum, minimum, or average),
- 19.1.6 Oxidizing or reducing nature of corrosive media,
- 19.1.7 Amount and nature of aeration and agitation of corrosive media,
- 19.1.8 Duration and type of test (if equipment was operated intermittently during the tests, the actual hours of operation should be stated as well as the total time of the test),
- 19.1.9 Surface condition of specimen (mill finished, polished, machined, pickled, 120 grit, etc.)

19.2 The form of corrosion that is documented should be reported, together with any observations on corrosion products or scales. The extent of each corrosive form should be quantified as described in 16.

19.2.1 Penetration damage should be expressed in millimetres and corrosion rates in millimetres per year (mm/y) for uniform or general corrosion (see Practice G 1). An evaluation based on mass loss is also sometimes used when corrosion has been substantially uniform in distribution over the surface of specimens; it is expressed as mass loss per square meter per day ($\text{g}/\text{m}^2/\text{day}$). The use of mass loss data to estimate corrosion penetration will be subject to error to the extent to which nonuniform distribution of corrosion and changes of corrosion rate with time occur.

19.2.2 The depth of pitting or crevice corrosion should be reported to the nearest 0.01 mm (0.0005 in.) for the test period and not interpolated or extrapolated to thousandths of an inch per year or any arbitrary period. The size, shape, and distribution of the pits should be noted. The surface area of the specimen and the area of the crevices should be recorded if crevice corrosion occurs.

The maximum depth of crevice corrosion that exists beneath the ~~coupon~~ specimen spacer must be reported.

20. Accuracy of Results

20.1 The reproducibility of plant corrosion tests is dependent on a number of factors, including the alloys tested, the variability of the environment, and the nature of the corrosion process. Accordingly, it is impossible to provide a general statement that will apply to all circumstances. In general, however, a variation of $\pm 20\%$ from the mean would be considered normal, while a variation of $\pm 50\%$ might be expected in some circumstances.

20.2 The ability of ~~coupons~~ corrosion test specimens to simulate the performance of the materials of construction of a process plant is largely dependent on the design of the program and the understanding of the corrosive process involved. A well-designed ~~coupon~~ test program should give results that correlate to the existing materials of construction within the limits mentioned in 20.1.

21. Keywords

21.1 ~~corrosive coupons; test specimens;~~ forms of corrosion; general corrosion rate; in-plant exposures; localized attack; specific size and surface conditions; test duration; test racks

ASTM International takes no position respecting the validity of any patent rights asserted in connection with any item mentioned in this standard. Users of this standard are expressly advised that determination of the validity of any such patent rights, and the risk of infringement of such rights, are entirely their own responsibility.

This standard is subject to revision at any time by the responsible technical committee and must be reviewed every five years and if not revised, either reapproved or withdrawn. Your comments are invited either for revision of this standard or for additional standards and should be addressed to ASTM International Headquarters. Your comments will receive careful consideration at a meeting of the responsible technical committee, which you may attend. If you feel that your comments have not received a fair hearing you should make your views known to the ASTM Committee on Standards, at the address shown below.

This standard is copyrighted by ASTM International, 100 Barr Harbor Drive, PO Box C700, West Conshohocken, PA 19428-2959, United States. Individual reprints (single or multiple copies) of this standard may be obtained by contacting ASTM at the above address or at 610-832-9585 (phone), 610-832-9555 (fax), or service@astm.org (e-mail); or through the ASTM website (www.astm.org).