



Standard Test Method for Measuring Abrasion Using the Dry Sand/Rubber Wheel Apparatus¹

This standard is issued under the fixed designation G 65; the number immediately following the designation indicates the year of original adoption or, in the case of revision, the year of last revision. A number in parentheses indicates the year of last reapproval. A superscript epsilon (ε) indicates an editorial change since the last revision or reapproval.

e¹ NOTE—This standard was previously named in error as G 65–00a

1. Scope

1.1 This test method covers laboratory procedures for determining the resistance of metallic materials to scratching abrasion by means of the dry sand/rubber wheel test. It is the intent of this test method to produce data that will reproducibly rank materials in their resistance to scratching abrasion under a specified set of conditions.

1.2 Abrasion test results are reported as volume loss in cubic millimetres for the particular test procedure specified. Materials of higher abrasion resistance will have a lower volume loss.

NOTE 1—In order to attain uniformity among laboratories, it is the intent of this test method to require that volume loss due to abrasion be reported only in the metric system as cubic millimetres. $1 \text{ mm}^3 = 6.102 \times 10^{-5} \text{ in}^3$.

1.3 This test method covers five recommended procedures which are appropriate for specific degrees of wear resistance or thicknesses of the test material.

1.3.1 *Procedure A*—This is a relatively severe test which will rank metallic materials on a wide volume loss scale from low to extreme abrasion resistance. It is particularly useful in ranking materials of medium to extreme abrasion resistance.

1.3.2 *Procedure B*—A short-term variation of Procedure A. It may be used for highly abrasive resistant materials but is particularly useful in the ranking of medium- and low-abrasive-resistant materials. Procedure B should be used when the volume-loss values developed by Procedure A exceeds 100 mm³.

1.3.3 *Procedure C*—A short-term variation of Procedure A for use on thin coatings.

1.3.4 *Procedure D*—This is a lighter load variation of Procedure A which is particularly useful in ranking materials of low-abrasion resistance. It is also used in ranking materials of

a specific generic type or materials which would be very close in the volume loss rates as developed by Procedure A.

1.3.5 *Procedure E*—A short-term variation of Procedure B that is useful in the ranking of materials with medium- or low-abrasion resistance.

1.4 *This standard does not purport to address the safety concerns, if any, associated with its use. It is the responsibility of the user of this standard to establish appropriate safety and health practices and determine the applicability of regulatory limitations prior to use.*

2. Referenced Documents

2.1 ASTM Standards:

D 2240 Test Method for Rubber Property—Durometer Hardness²

E 11 Specification for Wire-Cloth Sieves for Testing Purposes³

E 122 Practice for Choice of Sample Size to Estimate a Measure of Quality for a Lot or Process³

E 177 Practice for Use of the Terms Precision and Bias in ASTM Test Methods³

G 40 Terminology Relating to Wear and Erosion⁴

2.2 *American Foundrymen's Society Standards:*
AFS Foundry Sand Handbook, 7th Edition⁵

3. Terminology

3.1 Definition:

3.1.1 *abrasive wear*—wear due to hard particles or hard protuberances forced against and moving along a solid surface (Terminology G 40).

NOTE 2—This definition covers several different wear modes or mechanisms that fall under the abrasive wear category. These modes may

¹ This test method is under the jurisdiction of ASTM Committee G02 on Wear and Erosion and is the direct responsibility of Subcommittee G02.30 on Abrasive Wear.

Current edition approved Oct. 10, 2000. Published November 2000. Originally published as G 65 – 80. Last previous edition G 65 – 94 (2000)^{e1}.

² *Annual Book of ASTM Standards*, Vol 09.01.

³ *Annual Book of ASTM Standards*, Vol 14.02.

⁴ *Annual Book of ASTM Standards*, Vol 03.02.

⁵ Available from American Foundrymen's Society, Golf and Wolf Roads, Des Plaines, IL 60016.

degrade a surface by scratching, cutting, deformation, or gouging (1 and 6).⁶

4. Summary of Test Method

4.1 The dry sand/rubber wheel abrasion test (Fig. 1) involves the abrading of a standard test specimen with a grit of controlled size and composition. The abrasive is introduced between the test specimen and a rotating wheel with a chlorobutyl rubber tire or rim of a specified hardness. This test specimen is pressed against the rotating wheel at a specified force by means of a lever arm while a controlled flow of grit abrades the test surface. The rotation of the wheel is such that its contact face moves in the direction of the sand flow. Note that the pivot axis of the lever arm lies within a plane which is approximately tangent to the rubber wheel surface, and normal to the horizontal diameter along which the load is applied. The test duration and force applied by the lever arm is varied as noted in Procedure A through E. Specimens are weighed before and after the test and the loss in mass recorded. It is necessary to convert the mass loss to volume loss in cubic millimetres, due to the wide differences in the density of materials. Abrasion is reported as volume loss per specified procedure.

5. Significance and Use (1-7)

5.1 The severity of abrasive wear in any system will depend upon the abrasive particle size, shape, and hardness, the magnitude of the stress imposed by the particle, and the frequency of contact of the abrasive particle. In this practice these conditions are standardized to develop a uniform condition of wear which has been referred to as scratching abrasion (1 and 2). The value of the practice lies in predicting the relative ranking of various materials of construction in an abrasive environment. Since the practice does not attempt to

⁶ The boldface numbers in parentheses refer to the list of references at the end of this test method.

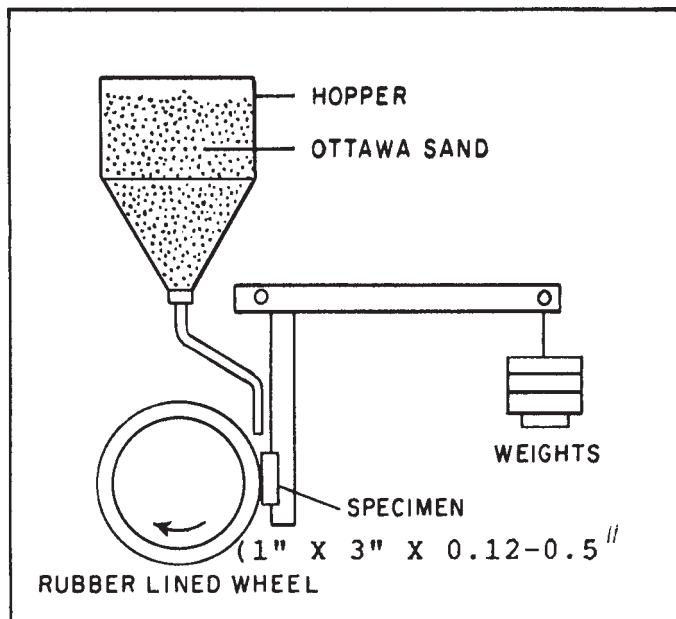

FIG. 1 Schematic Diagram of Test Apparatus

duplicate all of the process conditions (abrasive size, shape, pressure, impact, or corrosive elements), it should not be used to predict the exact resistance of a given material in a specific environment. Its value lies in predicting the ranking of materials in a similar relative order of merit as would occur in an abrasive environment. Volume loss data obtained from test materials whose lives are unknown in a specific abrasive environment may, however, be compared with test data obtained from a material whose life is known in the same environment. The comparison will provide a general indication of the worth of the unknown materials if abrasion is the predominant factor causing deterioration of the materials.

6. Apparatus and Material⁷

6.1 Fig. 2 shows a typical design and Fig. 3 and Fig. 4 are photographs of the test apparatus which may be constructed from readily available materials. Also, see Ref (2). Several elements are of critical importance to ensure uniformity in test results among laboratories. These are the type of rubber used on the wheel, the type of abrasive and the shape, positioning and the size opening of the sand nozzle, and a suitable lever arm system to apply the required force.

6.2 *Rubber Wheel*—The wheel shown in Fig. 5 shall consist of a steel disk with an outer layer of chlorobutyl rubber molded to its periphery. Uncured rubber shall be bonded to the rim and fully cured in a steel mold. The optimum hardness of the cured rubber is Durometer A-60. A range from A58 to 62 is acceptable. At least four hardness readings shall be taken on the rubber approximately 90° apart around the periphery of the wheel using a Shore A Durometer tester in accordance with Test Method D 2240. The gage readings shall be taken after a dwell time of 5 s. The recommended composition of the rubber and a qualified molding source is noted in Table 1. (See 9.9 for preparation and care of the rubber wheel before and after use and see Fig. 2 and Fig. 5.)

6.3 *Abrasive*—The type of abrasive shall be a rounded quartz grain sand as typified by AFS 50/70 Test Sand (Fig. 6).⁸ The moisture content shall not exceed 0.5 weight %. Sand that has been subjected to dampness or to continued high relative humidity may take on moisture, which will affect test results. Moisture content may be determined by measuring the weight loss after heating a sample to approximately 120°C (250°F) for 1 h minimum. If test sand contains moisture in excess of 0.5 % it shall be dried by heating to 100°C (212°F) for 1 h minimum and the moisture test repeated. In high-humidity areas sand may be effectively stored in constant temperature and humidity rooms or in an enclosed steel storage bin equipped with a 100-W electric bulb. Welding electrode drying ovens, available from welding equipment suppliers are also suitable. Multiple use of the sand may affect test results and is not recommended. AFS 50-70 Test Sand is controlled to the following size range using U.S. sieves (Specification E 11).

⁷ Original users of this test method fabricated their own apparatus. Machines are available commercially from several manufacturers of abrasion testing equipment.

⁸ Available from U.S. Silica Co., P.O. Box 577, Ottawa, IL 61350. Sand from other sources was not used in the development of this test method and may give different results.

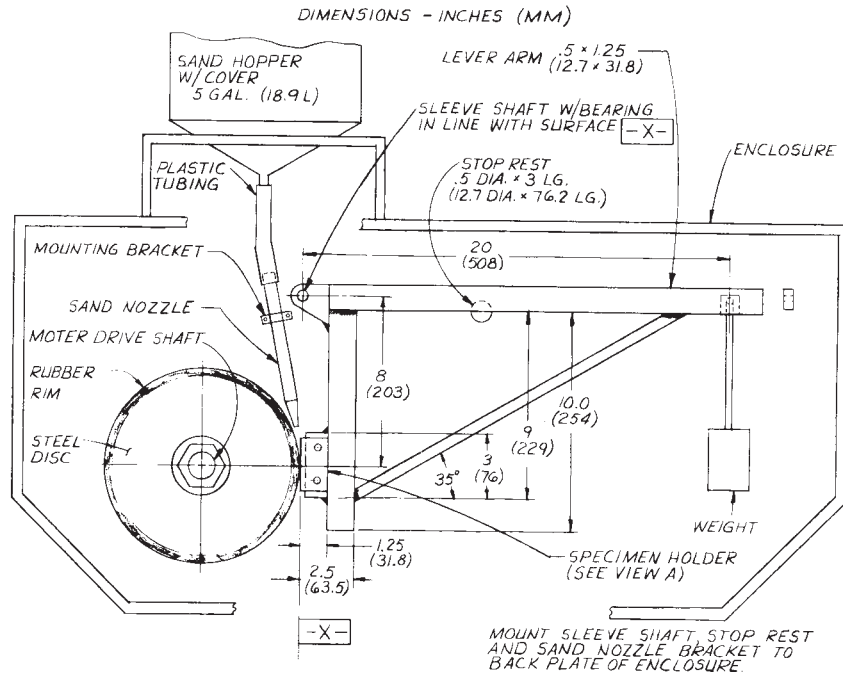
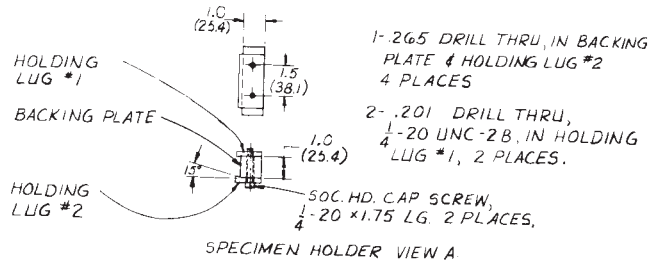

FIG. 2 Dry Sand/Rubber Wheel Abrasion Test Apparatus

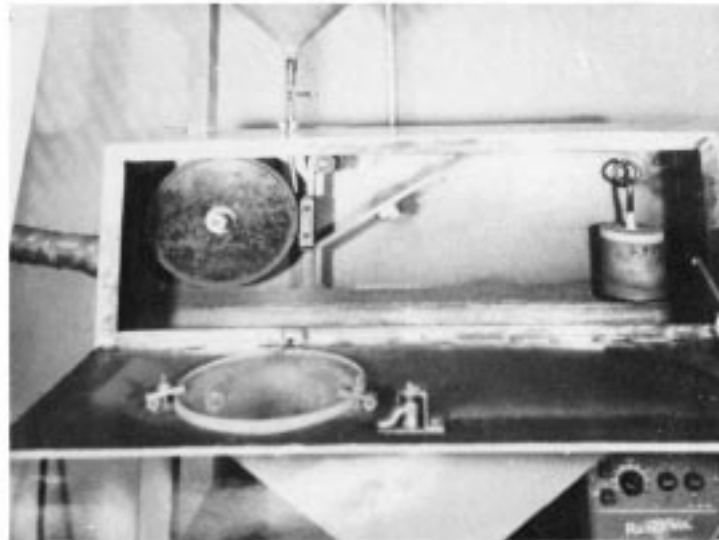

FIG. 3 Wheel and Lever Arm

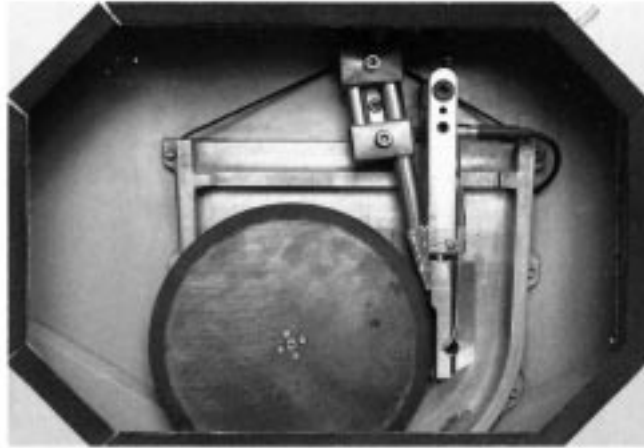

FIG. 4 Enclosure Frame

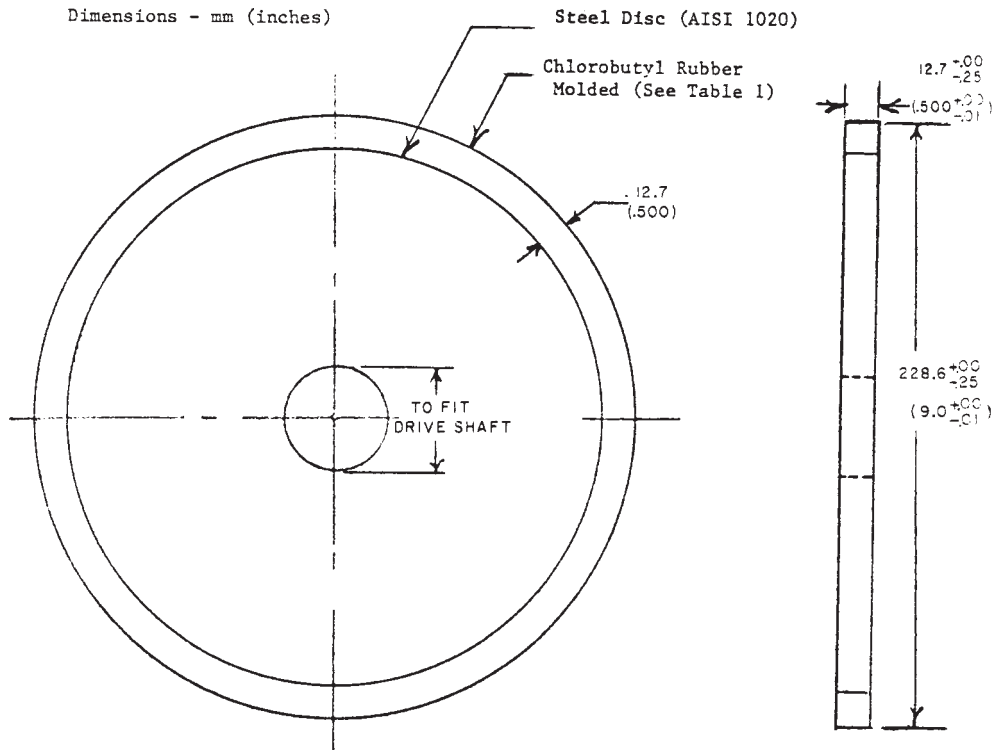

FIG. 5 Rubber Wheel

U.S. Sieve Size	Sieve Opening	% Retained on Sieve
40	425 μm (0.0165 in.)	none
50	300 μm (0.0117 in.)	5 max
70	212 μm (0.0083 in.)	95 min
100	150 μm (0.0059 in.)	none passing

6.4 *Sand Nozzle*—Fig. 7 shows the fabricated nozzle design which was developed to produce an accurate sand flow rate and proper shape of sand curtain for test procedures. The nozzle may be of any convenient length that will allow for connection to the sand hopper using plastic tubing. In new nozzles, the rate of sand flow is adjusted by grinding the orifice of the nozzle to increase the width of the opening to develop a sand flow rate of 300 to 400 g/min. During use, the nozzle opening must be positioned as close to the junction of the test specimen and the rubber wheel as the design will allow. (See Fig. 8.)

6.4.1 Any convenient material of construction that is available as welded or seamless pipe may be used for the construction of the fabricated nozzle. Stainless steel is preferred because of its corrosion resistance and ease of welding. Copper and steel are also used successfully.

6.4.2 *Formed Nozzle*—Nozzles formed from tubing may be used only when they duplicate the size and shape (rectangular orifice and taper), and the sand flow characteristics (flow rate and streamlined flow) of the fabricated nozzle. (See Fig. 7 and Fig. 9.)

6.4.3 *Sand Flow*—The nozzle must produce a sand flow rate of 300 to 400 g/min (0.66 to 0.88 lb/min).

6.4.4 *Sand Curtain*—Fig. 9 shows the proper stream-lined flow and the narrow shape of the sand curtain as it exits from

TABLE 1 Formula for Chlorobutyl Rubber^A

NOTE 1—Specific gravity of mix: 1.15. Pressure cure: 20 min at 160°C (320°F).

Materials	Proportions by Weight
Chlorobutyl No. HT 10-66 (Enjay Chemical)	100
Agerite Staylite-S	1
HAF black	60
Circolight oil	5
Stearic acid	1
Zinc oxide	5
Ledate	2

^A The sole source of supply known to the committee at this time is Action Rubber Co., Inc., 601 Fame Rd., Dayton, OH 45449. If you are aware of alternative suppliers, please provide this information to ASTM Headquarters. Your comments will receive careful consideration at a meeting of the responsible technical committee, which you may attend.

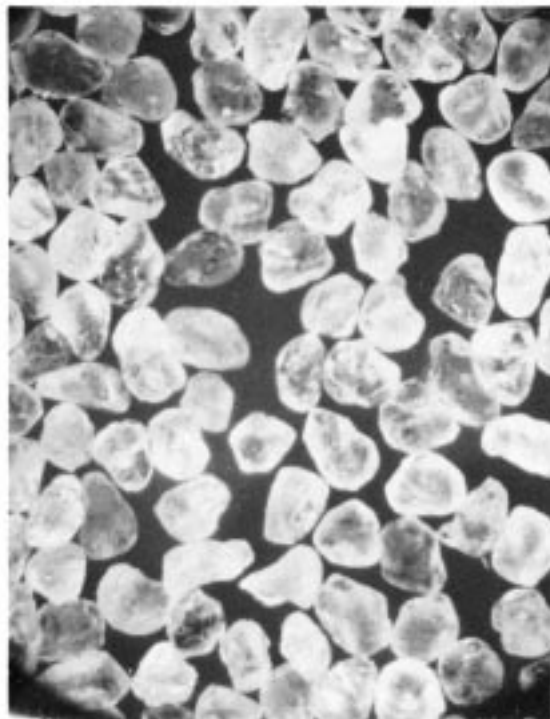

FIG. 6 25X Magnification AFS 50/70 Test Sand Ottawa Silica Co.

the sand nozzle. A turbulent sand flow as depicted in Fig. 10 will tend to produce low and inconsistent test results. It is intended that the sand flows in a streamlined manner and passes between the specimen and rubber wheel.

6.5 Motor Drive—The wheel is driven by a nominally 0.7-kW (1-hp) d-c motor through a 10/1 gear box to ensure that full torque is delivered during the test. The rate of revolution (200 ± 10 rpm) must remain constant under load. Other drives producing 200 rpm under load are suitable.

6.6 Wheel Revolution Counter—The machine shall be equipped with a revolution counter that will monitor the number of wheel revolutions as specified in the procedure (Section 9). It is recommended that the incremental counter have the ability to shut off the machine after a preselected number of wheel revolutions or increments up to 12 000 revolutions is attained.

6.7 Specimen Holder and Lever Arm—The specimen holder is attached to the lever arm to which weights are added, so that a force is applied along the horizontal diametral line of the wheel. An appropriate number of weights must be available to apply the appropriate force (Table 2) between the test specimen and the wheel. The actual weight required should not be calculated, but rather should be determined by direct measurement by noting the load required to pull the specimen holder away from the wheel. A convenient weight system is a can filled with sand (see Fig. 2).

6.8 Analytical Balance—The balance used to measure the loss in mass of the test specimen shall have a sensitivity of 0.001 g. Procedure C requires a sensitivity of 0.0001 g.

6.9 Enclosure, Frame, and Abrasive Hopper—Fig. 3 and Fig. 4 are photographs of a typical test apparatus. The size and shape of the support elements, enclosure, and hopper may be varied according to the user’s needs.

7. Specimen Preparation and Sampling

7.1 Materials—It is the intent of this test method to allow for the abrasion testing of any material form, including wrought metals, castings, forgings, gas or electric weld overlays, plasma spray deposits, powder metals, metallizing, electroplates, cermets, ceramics etc. The type of material will, to some extent, determine the overall size of the test specimen.

7.2 Typical Specimen, a rectangular shape 25 by 76 mm (1.0 by 3.0 in.) and between 3.2 and 12.7 mm (0.12 and 0.50 in.) thick. The size may be varied according to the user’s need with the restriction that the length and width be sufficient to show the full length of the wear scar as developed by the test. The test surface should be flat within 0.125 mm (0.005 in.) maximum.

7.3 Wrought, Cast, and Forged Metal—Specimens may be machined to size directly from the raw material.

7.4 Electric or Gas Weld Deposits are applied to one flat surface of the test piece. Double-weld passes are recommended to prevent weld dilution by the base metal. The heat of welding may distort the test specimen. When this occurs, the specimen may be mechanically straightened or ground, or both. In order to develop a suitable wear scar, the surface to be abraded must be ground flat to produce a smooth, level surface at least 63.4 mm (2.50 in.) long and 19.1 mm (0.75 in.) for the test. (See 7.5.) Note that the welder technique, heat input of welds, and the flame adjustment of gas welds will have an effect on the abrasion resistance of a weld deposit.

7.5 Finish—Test specimens should be smooth, flat, and free of scale. Surface defects such as porosity and roughness may bias the test results, and such specimens should be avoided unless the surface itself is under investigation. Typical suitable surfaces are mill-rolled surfaces such as are present on cold-rolled steel, electroplated and similar deposits, ground surfaces, and finely machined or milled surfaces. A ground surface finish of approximately 0.8 μm (32 μin.) or less is acceptable. The type of surface or surface preparation shall be stated in the data sheet.

FABRICATED SAND NOZZLE

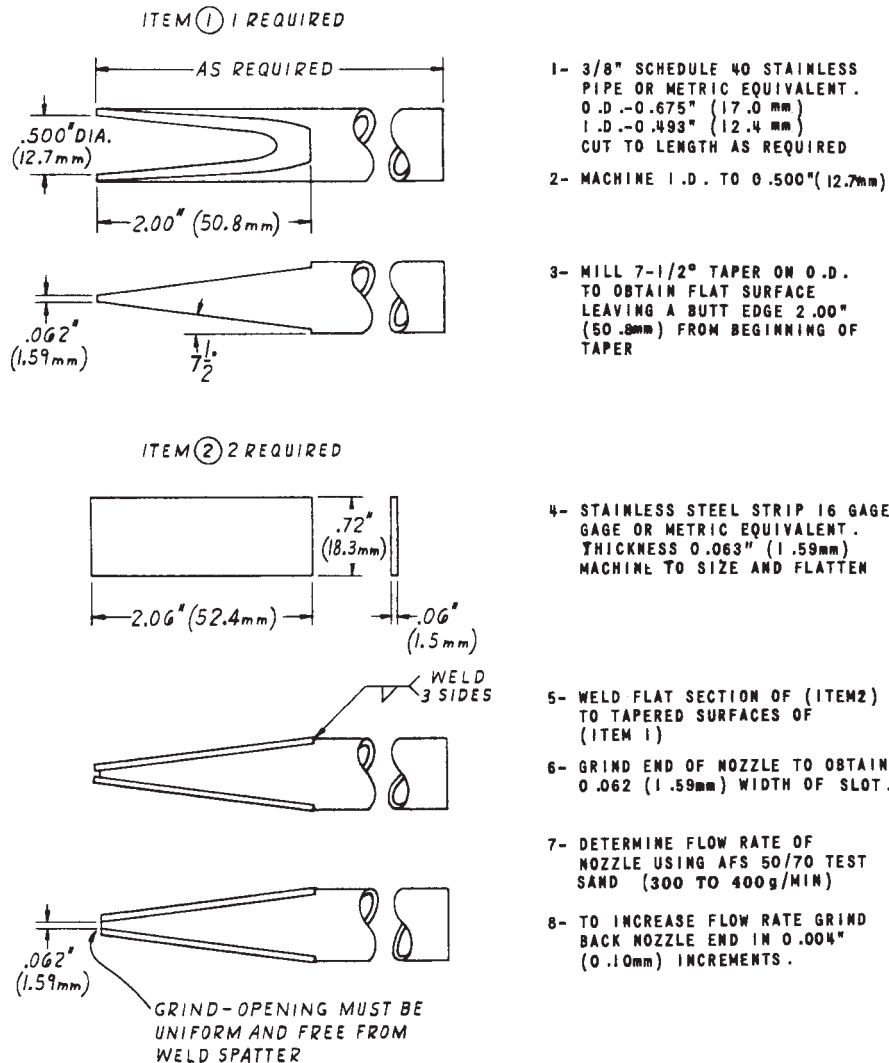

FIG. 7 Sand Nozzle

8. Test Parameters

8.1 Table 2 indicates the force applied against the test specimen and the number of wheel revolutions for test Procedures A through E.

8.2 Sand Flow—The rate of sand flow shall be 300 to 400 g/min (0.66 to 0.88 lb/min).

8.3 Time—The time of the test will be about 30 min for Procedures A and D, 10 min for Procedure B, 5 min for Procedure E, and 30 s for Procedure C, depending upon the actual wheel speed. In all cases the number of wheel revolutions and not the time shall be the controlling parameter.

8.4 Lineal Abrasion—Table 2 shows the lineal distance of scratching abrasion developed using a 228.6-mm (9-in.) diameter wheel rotating for the specified number of revolutions. As the rubber wheel reduces in diameter the number of wheel revolutions shall be adjusted to equal the sliding distance of a new wheel (Table 2) or the reduced abrasion rate shall be taken into account by adjusting the volume loss produced by the worn wheel to the normalized volume loss of a new wheel. (See 10.2.)

9. Procedure

9.1 Cleaning—Immediately prior to weighing, clean the specimen with a solvent or cleaner and dry. Take care to remove all dirt or foreign matter or both from the specimen. Dry materials with open grains (some powder metals or ceramics) to remove all traces of the cleaning solvent, which may have been entrapped in the material. Steel specimens having residual magnetism should be demagnetized or not used.

9.2 Weigh the specimen to the nearest 0.001 g (0.0001 g for Procedure C).

9.3 Seat the specimen securely in the holder and add the proper weights to the lever arm to develop the proper force pressing the specimen against the wheel. This may be measured accurately by means of a spring scale which is hooked around the specimen and pulled back to lift the specimen away from the wheel. A wedge should be placed under the lever arm so that the specimen is held away from the wheel prior to start of test. (See Fig. 2.)



FIG. 8 Position of Sand Nozzle

9.4 Set the revolution counter to the prescribed number of wheel revolutions.

9.5 *Sand Flow and Sand Curtain*—The rate of sand flow through the nozzles shall be between 300 g (0.66 lb)/min and 400 g (0.88 lb)/min. Do not start the wheel rotation until the proper uniform curtain of sand has been established (see Fig. 9 and Note 3).

9.5.1 The dwell time between tests shall be the time required for the temperature of the rubber wheel to return to room temperature. For Procedure B the dwell time shall be at least 30 min.

9.6 Start the wheel rotation and immediately lower the lever arm carefully to allow the specimen to contact the wheel.

9.7 When the test has run the desired number of wheel revolutions, lift the specimen away from the wheel and stop the sand flow and wheel rotation. The sand flow rate should be measured before and after a test, unless a consistent flow rate has been established.

9.8 Remove the specimen and reweigh to the nearest 0.001 g (0.0001 g for Procedure C).

9.8.1 *Wear Scar*—Observe the wear scar and compare it to the photographs of uniform and nonuniform wear scars in Fig. 11. A nonuniform pattern indicates improper alignment of the rubber rim to the test specimen or an unevenly worn rubber wheel. This condition may reduce the accuracy of the test.

9.9 *Preparation and Care of Rubber Wheels*—Dress the periphery of all new rubber wheels and make concentric to the bore of the steel disk upon which the rubber is mounted. The concentricity of the rim shall be within 0.05 mm (0.002 in.) total indicator reading on the diameter. Follow the same dressing procedure on used wheels that develop grooves or that

wear unevenly so as to develop trapezoidal or uneven wear scars on the test specimen (Fig. 11). The intent is to produce a uniform surface that will run tangent to the test specimen without causing vibration or hopping of the lever arm. The wear scars shall be rectangular in shape and of uniform depth at any section across the width. The rubber wheel may be used until the diameter wears to 215.9 mm (8.50 in.). New rubber rims may be mounted on steel disks by the qualified source (6.2).

9.10 *Wheel Dressing Procedure*—The preferred dressing procedure for the periphery of the rubber rim is to mount a diamond-cut file⁹ in place of the specimen in the holder and run the machine with load until the wheel is clean. Another dressing procedure for the periphery of the rubber rim is to mount the wheel on a lathe, and machine the surface with a tool bit especially ground for rubber applications. Grind a carbide or high-speed steel tool bit to very deep rake angles (Fig. 12). Feed the tool across the rubber surface in the opposite direction from that normally used for machining steel. This allows the angular surface of the tool bit to shear away thin layers of rubber without tearing or forming grooves in the rubber as would occur when using the pointed edges of the tool. The recommended machining parameters are: *Feed*—25 mm/min (1.0 in./min); *Speed*—200 rpm; *Depth of Cut*—0.254 mm (0.010 in.) to 0.762 mm (0.030 in.). The dressed wheel should be first used on a soft carbon steel test specimen (AISI 1020 or equivalent) using Procedure A. This results in a smooth, uniform, non-sticky surface. An alternative dressing method involves the use of a high-speed grinder on the tool post of a lathe. Take great care since grinding often tends to overheat and smear the rubber, leaving a sticky surface. Such a surface will pick up and hold sand particles during testing. If the grinding method is used, not more than 0.05 mm (0.002 in.) may be ground from the surface at one time so as to prevent overheating.

10. Calculating and Reporting Results

10.1 The abrasion test results should be reported as volume loss in cubic millimetres in accordance with the specified procedure used in the test. For example, ___mm³ per ASTM___ Procedure ___. While mass loss results may be used internally in test laboratories to compare materials of equivalent densities, it is essential that all users of this test procedure report their results uniformly as volume loss in publications or reports so that there is no confusion caused by variations in density. Convert mass loss to volume loss as follows:

$$\text{Volume loss, mm}^3 = \frac{\text{mass loss (g)}}{\text{density (g/cm}^3\text{)}} \times 1000 \quad (1)$$

10.2 *Adjusting the Volume Loss*—As the rubber wheel decreases in diameter the amount of scratching abrasion developed in a given practice will be reduced accordingly. The actual volume loss produced by these slightly smaller wheels

⁹ The sole source of supply known to the committee at this time is Falex Corp., 1020 Airpark Dr., Sugar Grove, IL 60554. If you are aware of alternative suppliers, please provide this information to ASTM Headquarters. Your comments will receive careful consideration at a meeting of the responsible technical committee, which you may attend.

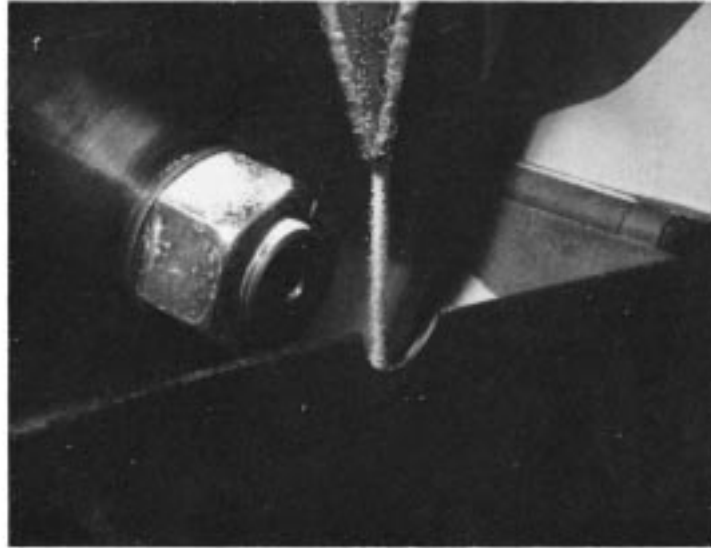

FIG. 9 Sand Flow—Streamlined



FIG. 10 Sand Flow—Turbulence

TABLE 2 Test Parameters

Specified Procedure	Force Against Specimen, ^B N (lb)	Wheel Revolutions	Lineal Abrasion ^A m (ft)
A	130 (30)	6000	4309 (14 138)
B	130 (30)	2000	1436 (4 711)
C	130 (30)	100	71.8 (236)
D	45 (10.1)	6000	4309 (14 138)
E	130 (30)	1000	718 (2 360)

^A See 8.4.

N = Newton (SI metric term for force)

1 lbf = 4.44822 N

1 Kgf = 9.806650 N

^B Force tolerance is ±3 %.

will, therefore, be inaccurate. The “adjusted volume loss” value takes this into account and indicates the actual abrasion rate that would be produced by a 228.6-mm (9.00-in.) diameter wheel. Calculate the adjusted volume loss (AVL) as follows:

$$AVL = \text{measured volume loss} \times \frac{228.6 \text{ mm (9.00 in.)}}{\text{wheel diameter after use}} \quad (2)$$

10.3 *Reporting Test Results*—All significant test parameters and test data as noted in Tables 2 and 3 shall be reported. Any variation from the recommended procedure must be noted in the comments. The report shall include a statement of the current precision and accuracy of the test apparatus as qualified by the testing of Reference Materials (11.6). The volume loss data developed by the initial qualification tests (11.4) or the volume loss data developed by the periodic re-qualification tests (11.4.3) should be listed on the data sheet (Table 3).

11. Precision and Bias

11.1 The precision and bias of the measurements obtained with this test method will depend upon strict adherence to the

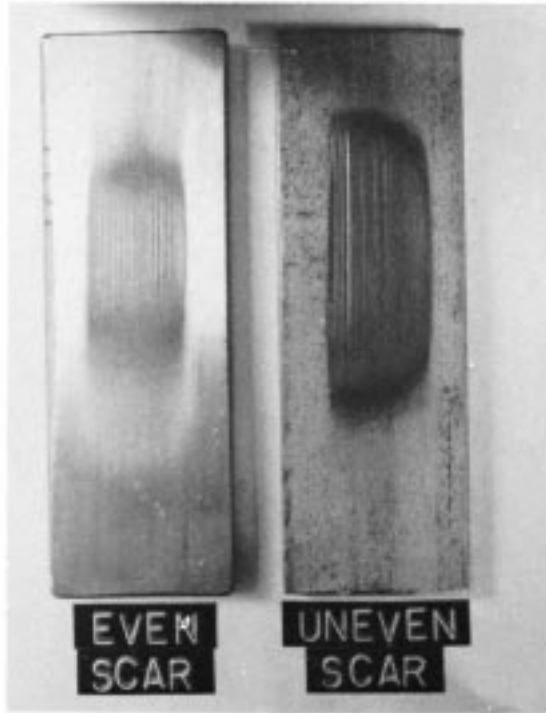

FIG. 11 Typical Wear Scars Uneven and Nonuniform Wear Scars Indicate Improper Alignment or Wear of Rubber Wheel

stated test parameters and maintenance of the proper sand flow rate and sand curtain throughout the duration of the test.

11.2 The degree of agreement in repeated tests on the same material will depend upon material homogeneity, machine and material interaction, and close observation of the test by a competent machine operator.

11.3 Normal variations in the abrasive, rubber wheel characteristics, and procedure will tend to reduce the accuracy of this test method as compared to the accuracy of such material property tests as hardness or density.

11.4 *Initial Machine Operation and Qualification*—The number of tests to establish precision and bias of the apparatus for initial machine operation shall be at least five. After initial qualification, a minimum of three tests may be used to periodically monitor precision and bias. These tests shall be made using Reference Materials (11.6) and the statistical calculations made, using formulas described in Practice E 122.

11.4.1 Tables X1.1 and X1.2 show representative coefficients of variation or standard deviations, or both, which were obtained in the interlaboratory tests. The coefficient of variation or the standard deviation, or both, for reference materials shall not exceed the values reported. If this value is exceeded, the machine operation shall be considered out of control and steps taken to eliminate erratic results.

11.4.2 The coefficient of variation tends to be higher for materials with volume losses in the range from 1 to 5 mm³. In such cases, the coefficient of variation is about 20 %.

11.4.3 In any test series all data must be considered in the calculation including outliers (data exceeding the obvious

range). For example, an exceedingly high- or low-volume loss must not be disregarded except in the case of observed faulty machine operation.

11.4.4 *Re-Qualification of Apparatus*—After the test apparatus has been initially qualified, it is required that one or more standard reference materials be periodically tested to ensure the accuracy of the data generated by the apparatus. This is particularly necessary when new test operators are involved or when the apparatus is not used on a regular basis. Re-qualification is also required for interlaboratory testing and for the qualification of materials as specified in customer and vendor contracts.

11.5 While two or more laboratories may develop test data that is within the acceptable coefficient of variation for their own individual test apparatus, their actual averages may be relatively far apart. The selection of sample size and the method for establishing the significance of the difference in averages shall be agreed upon between laboratories and shall be based on established statistical methods in Practices E 122, E 177, and Manual MNL 7.¹⁰

11.6 *Reference Materials*—Reference materials¹¹ may be used for periodic monitoring of the test apparatus and procedures in individual laboratories.

11.6.1 While any of the four test procedures (Table 2) may be used on reference materials, it is recommended that Procedure A be used for the more abrasion-resistant materials such as AISI D-2 Tool Steel. When Procedure A volume loss values exceed 100 mm³ in materials such as annealed low-carbon steel, greater accuracy in material ranking can be obtained by using Procedures B or D.

11.6.2 *Three Types of Reference Materials:*

11.6.2.1 *AISI D-2 Tool Steel (Nonfree-Machining Type)*—This is Reference Material No. 1 for Procedure A.¹²

- (a) (a) Harden 1010°C (1850°F)—25 min at temperature.
- (b) (b) Air cool to room temperature.
- (c) (c) Temper at 205°C (400°F)—1 h at temperature.
- (d) (d) Air Cool Hardness 59–60 HRC.
- (e) (e) Procedure A, qualifying volume loss range— 36 ± 5 mm³.

11.6.2.2 *AISI H-13 Tool Steel*—This is Reference Material No. 2 for Procedure B.¹³

- (a) (a) Harden 1010/1024°C (1850/1875°F) in neutral salt bath 25 min at temperature.
- (b) (b) Air cool to room temperature.
- (c) (c) Double temper at 593°C (1100°F) for 2 h and 2 h. Air cool between tempers. Hardness 47–48 HRC.

¹⁰ Manual on Presentation of Data and Control Chart Analysis, ASTM MNL 7, ASTM.

¹¹ Contact the Office of Standard Reference Materials, National Institute of Standards and Technology, Gaithersburg, MD 20899, or ASTM Headquarters.

¹² For information on D02 Tool Steel, Standard Reference Material No. 1857, contact the Office of Standard Reference Materials, National Institute of Standards and Technology, Gaithersburg, MD 20899.

¹³ For information on H-13 Tool Steel and 4340 steel contact ASTM Headquarters, Subcommittee G02.30. A qualified source for test specimen is 1020 Airpark Dr., Sugar Grove, IL 60554.

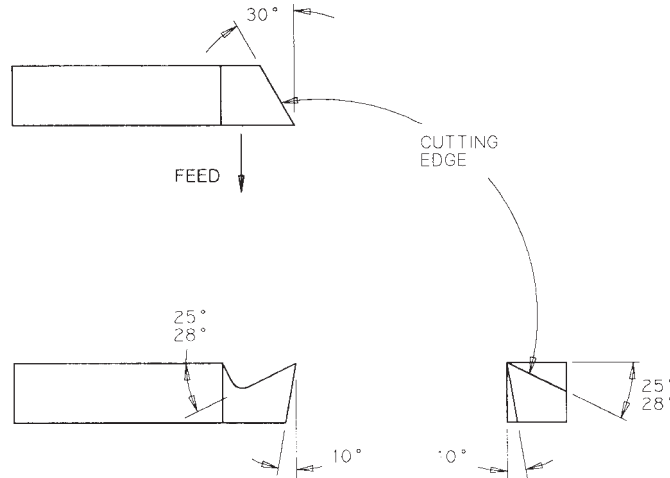

FIG. 12 Typical Wheel Dressing Tool

TABLE 3 Data Sheet

Dry Sand/Rubber Wheel Test ASTM G-65 Procedure _____						
Qualification of Apparatus (11.4):					Date _____	
Reference Materials _____					Quantity _____	
Adjusted Volume Loss (avg) _____ mm ³ Coefficient of Variation _____					%	
Test Data						
Material Description: _____					Wheel diameter: _____	
Heat Treatment: _____					Wheel width: _____	
Hardness: _____					Wheel hardness: _____	
Surface Preparation _____						
Test No.						
Test load						
Wheel revolutions						
Sand flow, g/min						
Initial mass, g						
Final mass, g						
Mass loss, g						
Density, g/cm ^{3A}						
Volume loss, mm ³ (mass loss/density) × 1000						
Adjusted volume loss, mm ³						
Comments: _____						
Company Name _____			Tested by _____		Date _____	

^A Density of materials may be obtained from *ASM Metals Handbook*, Vol 1, 8th ed. or suppliers of materials.

(d) (d) Procedure B, qualifying volume loss range—56 ± 4 mm³.

11.6.2.3 *AISI 4340 Steel*—This is Reference Material No. 3 for Procedures B or E.

(a) (a) Normalizing heat treatment.

(b) (b) Hardness 31-33 HRC.

(c) (c) Procedure E, qualifying volume loss range—49 ± 3 mm³.

(d) (d) Procedure B, qualifying volume loss range—91 ± 5 mm³.

11.6.3 Volume loss values for reference materials are developed in interlaboratory testing by the Abrasive Wear Task Group of ASTM Subcommittee G02.30.¹⁴ (See X1.3 for typical volume loss values of other materials.) It is the intent of Subcommittee G02.30 to develop several reference materials for abrasive wear testing.

¹⁴ Supporting data available from ASTM Headquarters. Request RR: G02-1006.

APPENDIX
(Nonmandatory Information)
X1. SOME STATISTICAL CONSIDERATIONS IN ABRASION TESTING
X1.1 Background

X1.1.1 The Dry Sand/Rubber and Wheel Abrasion Test as developed and described by Haworth, Avery, and others (1-7) has been in various stages of evolution and use since 1960. A number of variations of this test procedure have been used by several research and industrial laboratories in the United States who were faced with the problem of evaluating hard surfacing alloys, castings, and wrought products for their resistance to abrasive wear. Individual laboratories set their own test parameters with the goal being the generation of reproducible test data within the laboratory. As the need for standardization became apparent, Subcommittee G02.30 formed a task group to study the effect of each test parameter on the overall results within individual laboratories and among all laboratories as a group. While standardization of test parameters was attained, it became evident that the variability or experimental error inherent in each laboratory was a factor that must be considered. Not only must the test method, apparatus, and individual operator generate repeatable results, but the test results must be consistently reproducible within an acceptable range. Another important consideration in establishing repeatable and reproducible test results was the selection of an adequate sample size. More specifically this was the need for laboratories to agree on the number of times a test should be repeated on a given homogeneous material in order to obtain a meaningful average result. While single test results and simple arithmetic averaging may in some few cases be useful in individual laboratories, it is essential that statistical techniques and multiple testing of specimens be utilized for the qualification of each test apparatus, and for the comparison of materials. Further information on statistical methods may be found in Practice E 122, MNL 7, and in the references.

X1.2 Statistical Equations

X1.2.1 Several equations for the calculation of standard deviation and coefficient of variation are used in the statistical analysis of data shown in Table X1.1. To ensure uniformity among laboratories using the dry sand/rubber wheel test, the

standard deviation and coefficient of variation of results produced from a series of tests should be calculated by the following equations:

$$S_r = \sqrt{\frac{1}{p} (\sum S_j^2)} \quad (X1.1)$$

- d = deviations from average, $(\bar{x}_j - \bar{x})$
- $S_{\bar{x}}$ = $\sqrt{\frac{\sum(d^2)/p - 1}{p}}$
- S_L = $\sqrt{(S_{\bar{x}}^2) - (S_r^2)}$; $S_L = 0$ if the quantity under the root sign is negative.
- S_R = $\sqrt{(S_r^2) + (S_L^2)}$, is the reproducibility standard deviation of the test method for the parameter measured.
- $V_r(\%)$ = $100(S_r)/(\bar{x})$, the estimated relative standard deviation or coefficient of variation within a laboratory for the parameter measured (repeatability).
- $V_L(\%)$ = $100(S_L)/(\bar{x})$, the estimated relative standard deviation or coefficient of variation between laboratories for the parameter measured (reproducibility).

where:

- p = number of laboratories,
- n = number of replicate tests,
- \bar{x}_j = average of n number of replicate tests of each, laboratory of parameter j ,
- S_j = standard deviation,
- \bar{x} = average of \bar{x}_j 's for all laboratories of each parameter,
- S_r = estimated repeatability standard deviation within, and a laboratory for each parameter measured.

X1.3 Typical Volume Loss Values

X1.3.1 Procedure A of the Dry Sand/Rubber Wheel Test will produce volume losses in metallic materials ranging from 0.25 to 250 mm³. The more abrasion-resistant materials will develop the least volume loss. Table X1.2 shows typical volume loss ranges that may be expected in the metals listed. They are offered as guidelines only and not as purchasing specifications or as standard reference specimens. Any material

TABLE X1.1 Statistical Analyses of Interlaboratory Test Results

Round-Robin Test Conditions	Specified Procedure	Number of Samples	Average, mm ³	Standard Deviation Within, mm ³	Standard Deviation Between, mm ³	Coefficient of Variation Within, %	Coefficient of Variation Between, %	Coefficient of Variation Total, %	Standard Deviation Total, mm ³
RR No. 15 4340 steel	E	3	51.63	1.67	0.75	3.2	1.5	3.5	1.83
RR No. 14A and 14B 4340 steel	E	3	47.74	1.84	2.46	3.9	5.2	6.04	3.07
RR No. 14A and 14B 4340 steel	B	3	91.08	2.18	4.98	2.4	3.5	6	5.44
RR No. 12 WC-14 weight % CO 0.010 in. thick	A	4	2.18	0.14	0.42	6.4	19.3	20.4	0.44
RR No. 14 hard-chrome plating 0.010 in. thick	C	3	1.33	0.1	0.25	7.4	19.1	20.5	0.27

TABLE X1.2 Volume Loss Range

	Standard Values (Mean ± Standard Deviation) ^A				
	Practice A, mm ³	Practice B, mm ³	Practice C, mm ³	Practice D, mm ³	Practice E, mm ³
AISI Tool Steel D-2 Reference Material No. 1 ^B	35.6 ± 5.2
AISI Tool Steel H-13 Reference Material No. 2 ^B	...	55.6 ± 4.2
AISI 4340 Steel Reference Material No. 3 ^B	91.1 ± 5.4	49.2 ± 2.9
	Nonstandard Values				
316 stainless bar annealed RB-80	260 ± 20	58.5 ± 26.6	...
AISI 1090 plate-normalized 900°C (1600°F) air-cooled 24-26 HRC	80.7 ± 8.0	33.0 ± 6.0	...
17-4PH stainless-aged 500°C (925°F)-4 h at temperature, air-cooled-43 HRC	220 ± 20	122.1 ± 15.3	...	70.9 ± 6.1	...
Stellite 1016 hard surfacing overlay 57-58 HRC applied by oxyacetylene welding process (35 flame)	17 ± 4
Sintered tungsten carbide (Kennametal K-714, Valenite 2889)	1.9 ± 0.3
WC-Co flame spray coatings	2.2 ± 0.4
Hard-chrome plating	1.3 ± 0.3

^A The mean values and standard deviation for volume loss reported were calculated from the values in Research Report RR:G02.1006.

^B See 11.6.2 for heat treat.

specifications involving this test method must be by agreement between the seller and the purchaser. When volume losses exceed 100 mm³, greater accuracy in material ranking is obtained by using Procedure D (see Table 2). Procedure A

should be used for the more abrasion-resistant materials. Procedure E or B can be used for materials with volume losses in the range from 50 to 100 mm.⁵

REFERENCES

- (1) Avery, H. S., "The Nature of Abrasive Wear," *SAE Preprint 750822*, Society of Automotive Engineers, Warrendale, PA, 1975.
- (2) Tucker, R. C., and Miller, A. E., *Low Stress Abrasive and Adhesive Wear Testing, ASTM STP 615*, Philadelphia, PA, 1975, pp. 68–90.
- (3) Avery, H. S., "The Measurement of Wear Resistance," *Wear*, Vol 4, No. 6, November/December 1961, pp. 427–449.
- (4) "Report of Iron and Steel Technical Committee," *Abrasive Wear*, J965, Society of Automotive Engineers, 1966.
- (5) Borik, F., "Rubber Wheel Abrasion Test," *SAE Preprint 700687*, Society of Automotive Engineers, 1970.
- (6) Avery, H. S., "Classification and Precision of Abrasion Tests," *Source Book on Wear Control Technology*, American Society for Metals, Metals Park, OH, 1978.
- (7) Haworth, R. D., Jr., "The Abrasion Resistance of Metals," *Transactions American Society for Metals*, Vol 41, 1949, pp. 819–854.

ASTM International takes no position respecting the validity of any patent rights asserted in connection with any item mentioned in this standard. Users of this standard are expressly advised that determination of the validity of any such patent rights, and the risk of infringement of such rights, are entirely their own responsibility.

This standard is subject to revision at any time by the responsible technical committee and must be reviewed every five years and if not revised, either reapproved or withdrawn. Your comments are invited either for revision of this standard or for additional standards and should be addressed to ASTM International Headquarters. Your comments will receive careful consideration at a meeting of the responsible technical committee, which you may attend. If you feel that your comments have not received a fair hearing you should make your views known to the ASTM Committee on Standards, at the address shown below.

This standard is copyrighted by ASTM International, 100 Barr Harbor Drive, PO Box C700, West Conshohocken, PA 19428-2959, United States. Individual reprints (single or multiple copies) of this standard may be obtained by contacting ASTM at the above address or at 610-832-9585 (phone), 610-832-9555 (fax), or service@astm.org (e-mail); or through the ASTM website (www.astm.org).