



Standard Guide for Evaluating Characteristics of Ultrasonic Search Units¹

This standard is issued under the fixed designation E 1065; the number immediately following the designation indicates the year of original adoption or, in the case of revision, the year of last revision. A number in parentheses indicates the year of last approval. A superscript epsilon (ϵ) indicates an editorial change since the last revision or reapproval.

1. Scope

1.1 This guide covers measurement procedures for evaluating certain characteristics of ultrasonic search units (also known as “transducers”) that are used with ultrasonic examination instrumentation. This guide describes means for obtaining performance data that may be used to define the acoustic and electric responses of ultrasonic search units.

1.2 The procedures are designed to measure search units as individual components (separate from the ultrasonic test instrument) using commercial search unit characterization systems or using laboratory instruments such as signal generators, pulsers, amplifiers, oscilloscopes, and waveform analyzers.

1.3 The procedures are applicable to manufacturing acceptance and incoming inspection of new search units or to periodic performance evaluation of search units throughout their service life.

1.4 The procedures in Annex A1-Annex A6 are generally applicable to ultrasonic search units operating within the 0.4 to 10 MHz range. Annex A7 is applicable to higher frequency immersion search unit evaluation. Annex A8 describes a guide for measuring sound beam profiles in metals from contact straight-beam search units. Additional Annexes, such as sound beam profiling for angle-beam search units in metal and alternate means for search unit characterization, will be added when developed.

1.5 The values stated in inch-pound units are to be regarded as standard.

1.6 *This standard does not purport to address all of the safety concerns, if any, associated with its use. It is the responsibility of the user of this standard to establish appropriate safety and health practices and determine the applicability of regulatory limitations prior to use.*

2. Referenced Documents

2.1 ASTM Standards:

E 1316 Terminology for Nondestructive Examinations²

2.2 Other Document:

¹ This guide is under the jurisdiction of ASTM Committee E07 on Nondestructive Testing and is the direct responsibility of Subcommittee E07.06 on Ultrasonic Method.

Current edition approved July 10, 2003. Published September 2003. Originally approved in 1985. Last previous edition approved in 1999 as E 1065 – 99.

² *Annual Book of ASTM Standards*, Vol 03.03.

Standard Methods for Testing Single Element Pulse-Echo Ultrasonic Transducers³

3. Terminology

3.1 *Definitions*—For definitions of terms used in this guide, see Terminology E 1316.

3.2 Definitions of Terms Specific to This Standard:

3.2.1 *aperture*—the dimension(s) of the active area of the piezoelectric element of the search unit as established by experimentation.

3.2.2 *bandwidth (BW)*—that portion of the frequency response that falls within given limits. In this text, the limits used are the -6 dB level, as measured from the peak of the frequency response. The equation used for *BW* is:

$$BW = (f_u - f_l)/f_c \times 100 \quad (1)$$

where:

f_u = upper frequency,

f_l = lower frequency, and

f_c = center frequency.

Bandwidth is expressed as a percentage.

3.2.3 *center frequency (f_c)*—the frequency value calculated to be at the center of the bandwidth limits.

3.2.4 *depth of field (F_D)*—as measured on the on-axis profile of a focused search unit, that portion of the sound beam that falls within given limits.

3.2.5 *focal length (F_L)*—for focused search units, the distance from the lens to the focal point.

3.2.6 *focal point (F_p)*—for focused search units, the point along the acoustic axis of the beam in water at which the peak (maximum) pulse-echo amplitude response is recorded from a ball target reflector.

3.2.7 *frequency response*—the pulse-echo response of the search unit measured as a function of frequency. (This term also referred to as frequency spectrum.)

3.2.8 *nominal frequency (f_{nom})*—the frequency stated on the label supplied by the manufacturer.

3.2.9 *on-axis profile*—a sequence of measurements made along the acoustic axis of the beam of the search unit.

3.2.10 *peak frequency (f_p)*—the frequency value at the maximum amplitude of the frequency response.

³ Available from the American Institute of Ultrasonics in Medicine, 14750 Sweitzer Lane, Suite 100, Laurel, MD 20707-5906.

3.2.11 *pulse duration*—the length of the sinusoidal burst used to excite the search unit as expressed in time or number of cycles (sometimes referred to as tone-burst).

3.2.12 *pulse echo sensitivity*—a measurement that compares the amplitude of the applied voltage with the amplitude of the pulse-echo voltage recorded from a specified target.

3.2.13 *shock excitation*—a short electrical impulse that is applied to the search unit. The impulse is typically a negative-going voltage spike of fast rise time and short duration.

3.2.14 *transverse profile*—sequence of measurements made along a line perpendicular to the acoustic axis of the beam of the search unit.

3.2.15 *waveform duration*—the time interval or duration over which the unrectified signal or echo from a specified target exceeds a selected amplitude level as related to the maximum amplitude of the signal or echo (for example, -20 or -40 dB).

4. Summary of Guide

4.1 The acoustic and electrical characteristics which can be described from the data obtained by procedures outlined in this guide are described as follows:

4.1.1 *Frequency Response*—The frequency response may be obtained from one of two procedures: (a) shock excitation and (b) sinusoidal burst. Annex A1 describes procedures for obtaining frequency response for immersion and zero-degree contact search units. Annex A2 describes the procedure for obtaining bandwidth characteristics.

4.1.2 *Relative Pulse-Echo Sensitivity (S_{rel})*—The relative pulse-echo sensitivity may be obtained from the frequency response data obtained using the sinusoidal burst procedure described in Annex A1. The value is obtained from the relationship of the amplitude of the voltage applied to the search unit and the amplitude of the pulse-echo signal received from a specified target. Annex A3 describes the procedure for obtaining pulse-echo sensitivity.

NOTE 1—Values for applied and received *power*, from which *insertion loss* might be determined are not covered with procedures described in this guide.

4.1.3 *Time Response*—The time response provides a means for describing the radio frequency (rf) response of the waveform. A shock excitation, pulse-echo procedure is used to obtain the response. The time or waveform responses are recorded from specific targets that are chosen for the type of search unit under evaluation (for example, immersion, contact straight beam, or contact angle beam). Annex A4 describes the procedures for measuring time response.

4.1.4 *Electrical Impedance*:

4.1.4.1 *Complex Electrical Impedance*—The complex electrical impedance may be obtained with commercial impedance measuring instrumentation, and these measurements may be used to provide the magnitude and phase of the impedance of the search unit over the operating frequency range of the unit. These measurements are generally made under laboratory conditions with minimum cable lengths or external accessories and in accordance with the instructions of the instrument manufacturer. The value of the magnitude of the complex

electrical impedance may also be obtained using values recorded from the sinusoidal burst techniques as outlined in Annex A5.

4.1.4.2 *d-c Resistance*—The d-c resistance of the search unit may provide information regarding the electrical tuning elements. Measurements are made across the terminals of the unit.

4.1.5 *Sound Field Measurements*—The objective of these measurements is to establish parameters such as the on-axis and transverse sound beam profiles for immersion flat and focused search units.

4.1.5.1 Annexes A6 and A8 of this guide describe ways for making sound field measurements for both immersion flat and focused search units in water and contact straight-beam search units in metal. The literature discusses several ways for making these measurements, but the techniques described are relatively simple and easily performed.

4.1.5.2 Means are recommended for making measurements in an immersion tank, thereby allowing either pulse-echo (ball target) or hydrophone receiver techniques to be followed. The goal is to provide measurements to evaluate the characteristics of search units or to identify changes that may occur as a function of time or use, or both.

4.1.5.3 None of the measurements of sound beam patterns are intended to define limits of performance. They are designed to provide a common means for making measurements that may be used to define the initial and inservice performance.

NOTE 2—No procedure is given for measuring sound beam profile characteristics for angle-beam search units. Several potential approaches are being considered, but have not yet gained subcommittee agreement (1).⁴

NOTE 3—*Frequency Response Displays*. The frequency responses in Fig. 1 and Fig. 2 and throughout the text are displayed as a linear amplitude (not logarithmic) response as a function of frequency. The recording or line drawing shows only the positive component or envelope of the responses. While this is the normal display for a spectrum analyzer, the sinusoidal burst response is shown as only one-half of the actual sinusoidal wave.

5. Significance and Use

5.1 This guide is intended to provide standardized procedures for evaluating ultrasonic search units. It is not intended to define performance and acceptance criteria, but rather to provide data from which such criteria may be established.

5.2 These procedures are intended to evaluate the characteristics of single-element piezoelectric search units.

5.3 Implementation may require more detailed procedural instructions in a format of the using facility.

5.4 The measurement data obtained may be employed by users of this guide to specify, describe, or provide a performance criteria for procurement and quality assurance, or service evaluation of the operating characteristics of ultrasonic search units. All or portions of the guide may be used as determined by the user.

⁴ The boldface numbers in parentheses refer to a list of references at the end of this test method.

Shock Excitation —
Frequency and Time Responses

User May Add Other Data About Search Unit, e.g. MFG, Style Type, Serial No., Cable Target etc.

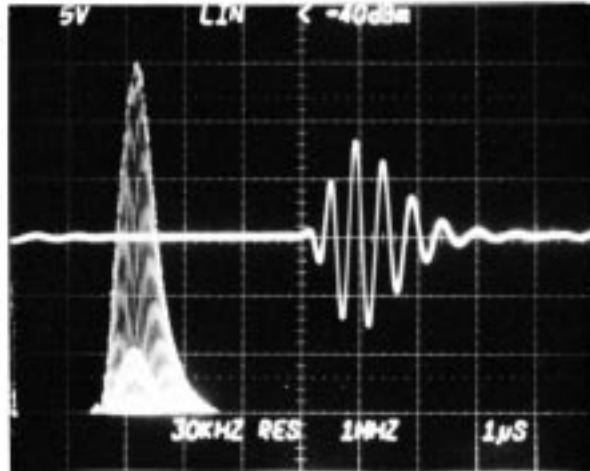

Peak Frequency ----- f_p	2.2 MHz	Bandwidth --- BW	32%
Center Frequency ----- f_c	2.15 MHz	Waveform Duration:	
Upper Frequency @ -6dB f_u	2.5 MHz	@ -20dB level	3 μ sec
Lower Frequency @ -6dB f_l	1.8 MHz	@ -40dB level	3.7 μ sec

FIG. 1 Test Data Available from Shock Excitation Procedure

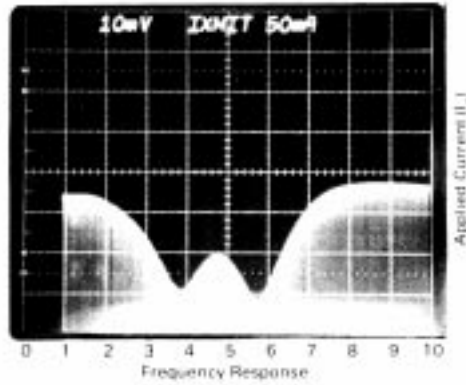
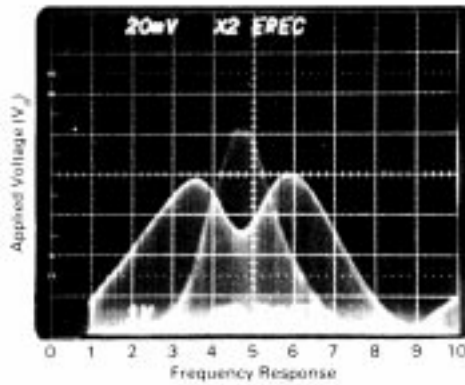

User May Add Other Data About Search Unit e.g. MFG, Style, Type, Serial No., Cable, Target etc.

Peak Frequency ----- f_p	4.7 MHz	Bandwidth ----- BW	43%
Center Frequency ----- f_c	4.7 MHz	Relative Sensitivity -- Srel	-27dB
Upper Frequency @ -6dB f_u	5.7 MHz	Electrical Impedance (mag)	52 Ω
Lower Frequency @ -6dB f_l	3.7 MHz		

FIG. 2 Test Data Available from Sinusoidal Burst Technique

5.5 The measurements are made primarily under pulse-echo conditions. To determine the relative performance of a search unit as either a transmitter or a receiver may require additional tests.

5.6 While these procedures relate to many of the significant parameters, others that may be important in specific applications may not be treated. These might include power handling

capability, breakdown voltage, wear properties of contact units, radio-frequency interference, and the like.

5.7 Care must be taken to ensure that comparable measurements are made and that users of the guide follow similar procedures. The conditions specified or selected (if optional) may affect the test results and lead to apparent differences.

5.8 Interpretation of some test results, such as the shape of the frequency response curve, may be subjective. Small irregularities may be significant. Interpretation of the test results is beyond the scope of this guide.

5.9 Certain results obtained using the procedures outlined may differ from measurements made with ultrasonic test instruments. These differences may be attributed to differences in the nature of the experiment or the electrical characteristics of the instrumentation.

5.10 The pulse generator used to obtain the frequency response and time response of the search unit must have a rise time, duration, and spectral content sufficient to excite the search unit over its full bandwidth, otherwise time distortion and erroneous results may result.

6. Typical Results Obtainable from Tests Described in Annex A1-Annex A5

6.1 Fig. 1 illustrates some of the typical results that may be obtained using shock excitation techniques. Values for fre-

quency response, peak frequency, bandwidth, bandwidth center frequency, and time response may be obtained.

6.2 Fig. 2 illustrates the typical results obtained using the sinusoidal burst technique. Values may be obtained for frequency response, peak frequency, bandwidth, bandwidth center frequency, relative pulse-echo sensitivity, and magnitude of the electrical impedance from the data recorded with this technique.

7. Keywords

7.1 aperture; bandwidth; characterization; contact testing; depth of field; focal point; frequency response; immersion testing; peak frequency; search unit; sound beam profile; time response; ultrasound

ANNEXES

(Mandatory Information)

A1. MEASUREMENT OF FREQUENCY RESPONSE

A1.1 *Introduction*—The frequency response (also known as frequency spectrum) is a measure of the amplitude of the pulse-echo response from a given target as a function of frequency. This response is used as the basis for establishing other operating parameters of the search unit including peak frequency, center frequency (see Annex A1), bandwidth (see Annex A2) and sensitivity (see Annex A3). Sketches of typical response curves are shown in Fig. A1.1. These sketches are used to describe two conditions: (a) a response that is symmetrical about a center frequency, and (b) a condition in which the frequency response is asymmetrical.

A1.1.1 Two means are described for obtaining the frequency response: (a) shock excitation, and (b) sinusoidal burst. The responses obtained using these procedures provide similar results; however, reproducibility is dependent on factors such as generator driving impedance, search unit impedance, pulse shape, and measurement systems. The measurement system to be used for search unit evaluation should be established by users of the guide.

A1.2 *Shock Excitation Technique*—The shock excitation technique for obtaining frequency response is based on the principle that a shock pulse applied to the search unit produces a broad spectrum of energies and that the echo from a given target reflects the frequency distribution that is characteristic of that search unit. Measurements may be made using either the analog or digitized rf waveform. Fig. A1.2 describes typical components used to measure frequency response of an rf analog waveform. The system consists of a search unit, shock pulse generator (pulser), preamplifier (receiver), electronic gate that can be adjusted to capture the echo waveform, display

oscilloscope, and spectrum analyzer. Fig. A1.3 describes typical components used to measure the frequency response of a digitized rf waveform. The system consists of a search unit, pulser, receiver, gate that can be adjusted to capture the echo waveform, analog to digital converter (digitizer), Fourier transform calculator, and display. To make the measurement, an excitation pulse is applied to the search unit and an echo is obtained from a specific target. The gated echo is monitored on an oscilloscope to ensure that only the desired rf waveform is analyzed. The gated analog rf waveform is input to the spectrum analyzer, (see Fig. A1.2). The gated digitized waveform is input to the Fourier transform calculator and displayed, (see Fig. A1.3). The resultant spectrum describes the frequency response of the search unit.

NOTE A1.1—*Special Notice for Frequency Response Measurements.* With correct settings, the results from the shock excitation and sinusoidal burst procedures will produce similar results. However, because of the multiple variables associated with electronic components and adjustments, some differences may result. Users of the guide must identify the parameters that will be used to make the measurements.

NOTE A1.2—Pulser generators used for shock excitation of search units are designed to have low driving or *on* impedances and high *off* impedances. Generally, the duration of the pulse can be adjusted to provide a maximum energy transfer to a search unit. As the pulse duration and the output impedance of the generator may influence the actual spectrum delivered to the search unit, care must be exercised to ensure that the spectrum of energies applied is sufficient to accurately describe the frequency response of the search unit. Operating parameters of the pulser should be established by users of the guide. The electrical impedance of the receiver used can have an influence on the frequency response. The input impedance of the receiver should be high (500 ohms or higher) to reduce the potential adverse influence.

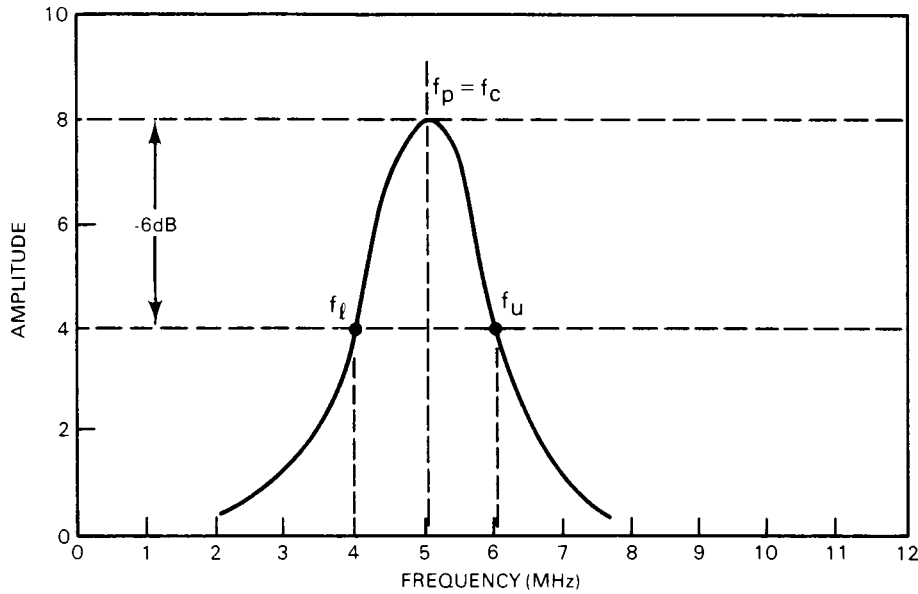

(a) Symmetrical-Response Curve

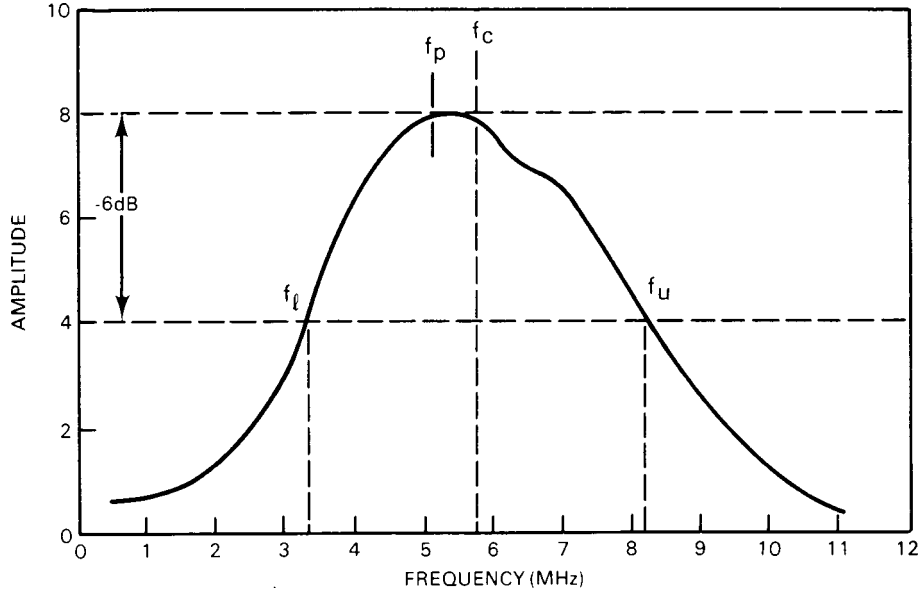

(b) Asymmetrical-Response Curve

FIG. A1.1 Frequency-Response Curves

NOTE A1.3—For measurement of frequency response, a digitizer capable of providing a minimum of ten samples per cycle at the nominal frequency of the search unit is recommended. A sufficient number of cycles should be sampled to reliably reproduce the spectrum of the echo waveform. Averaging a number of waveforms increases the reliability of measurements. Specific requirements may be established between the supplier and user.

NOTE A1.4—When using the shock excitation technique, the returning echo should be gated such that the gate is wider than the echo to ensure that the rising and decaying portions of the waveform are included in the frequency response analysis. If a portion of the time response is excluded from the frequency response, this should be clearly documented by showing the gate position and width relative to the waveform.

A1.3 *Sinusoidal Burst Technique*—The principle is to apply a sinusoidal burst of a known voltage and frequency to the

search unit and determine its pulse-echo response. By varying the frequency of the sinusoidal burst across the operating range of the search unit and recording the echo response at each frequency, a plot of the acoustic frequency is obtained (2).

A1.3.1 Fig. A1.4 is a block diagram for a system designed for displaying and recording the frequency response. The function generator is adjusted to produce sinusoidal bursts across the range of frequencies anticipated for the operating frequency of the search unit (for example, 1 to 5 MHz for 2.5 MHz, 1 to 10 MHz for 5 MHz, etc.). The generator pulse width is adjusted to provide a minimum pulse duration of 15 cycles at the lowest measurement frequency. The sinusoidal burst (see Fig. A1.4, Position A) is applied to the search unit and the

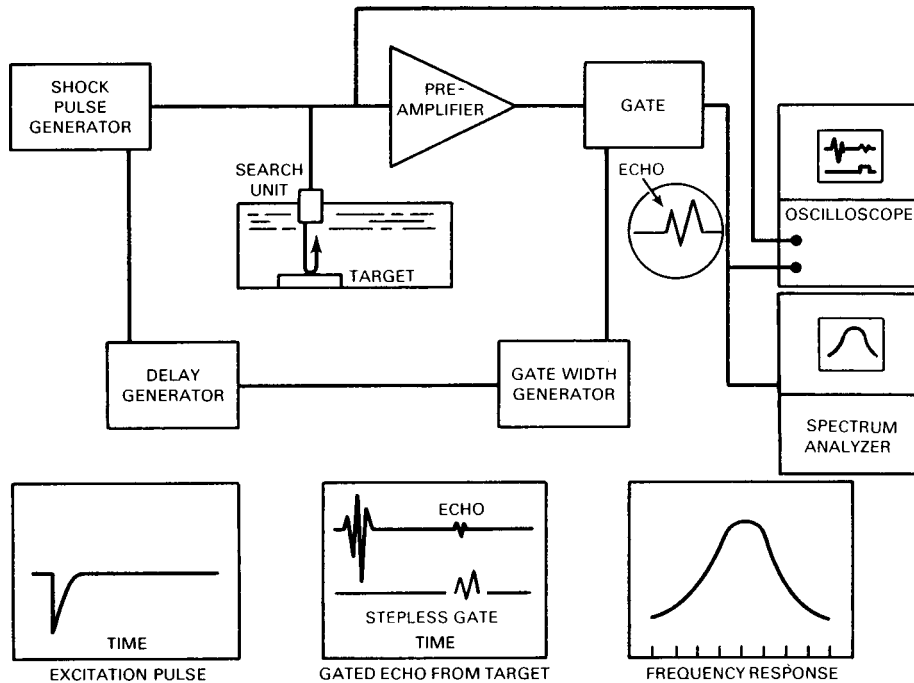

FIG. A1.2 Block Diagram of Shock Excitation System Used to Obtain Analog rf Waveform Information

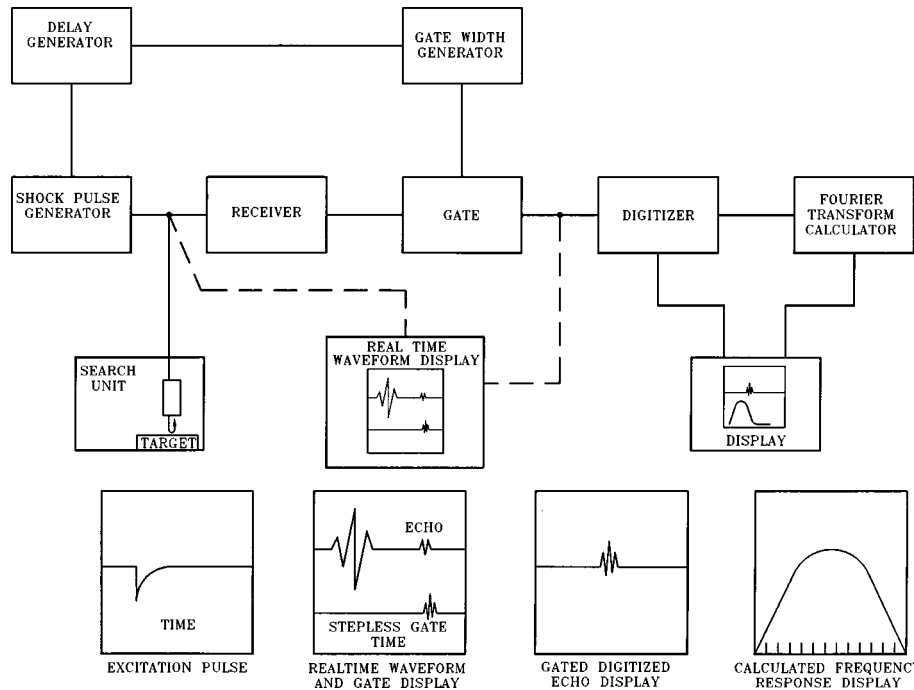

FIG. A1.3 Block Diagram of Shock Excitation System Used to Obtain Digitized rf Waveform Information

pulse-echo response from a given target is recorded for a specific frequency. The frequency of the bursts is stepped through the frequency range and the pulse-echo voltage response is recorded at each frequency. The returning echo is gated (Position B) to the center one-half of the echo response to ensure that transients from the generator or electronics do not influence the measurements. Both the amplitude of the applied voltage and the amplitude of the echo response are plotted as a function of frequency (Position C).

A1.3.2 Influence of Generator Output—Commercial sinusoidal burst generators typically are designed to provide a constant-voltage output into a 50-ohm resistance load. When these generators are loaded by an ultrasonic search unit, the output driving voltage may vary with frequency, depending on the impedance of the search unit.

A1.3.2.1 Recording Procedure—The initial step in the sinusoidal burst recording procedure is to terminate the generator with a 50-ohm resistive load and establish that the output

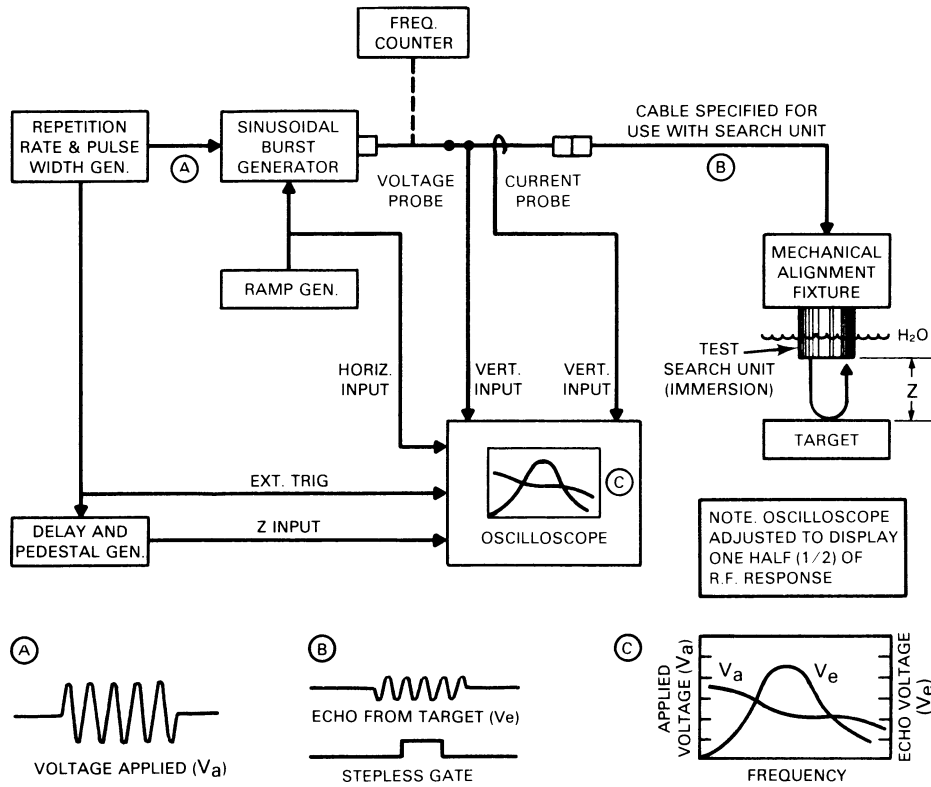

FIG. A1.4 Block Diagram of a Sinusoidal Burst System (Frequency Response)

voltage is constant over the frequency range of interest. Once this is established, the 50-ohm resistor is removed and the search unit is connected. The frequency response is obtained without further adjustment of the generator drive voltage. The frequency response and the applied voltage are recorded, thereby showing the influence of the electrical impedance of the search unit:

A1.4 *Specific Procedures*—The sinusoidal burst and shock excitation procedures are applicable to nearly all types of search units. The procedures for evaluating the characterization of various styles are outlined as follows:

A1.4.1 *Immersion*—Fig. A1.5 shows the test setup for obtaining frequency response for immersion units.

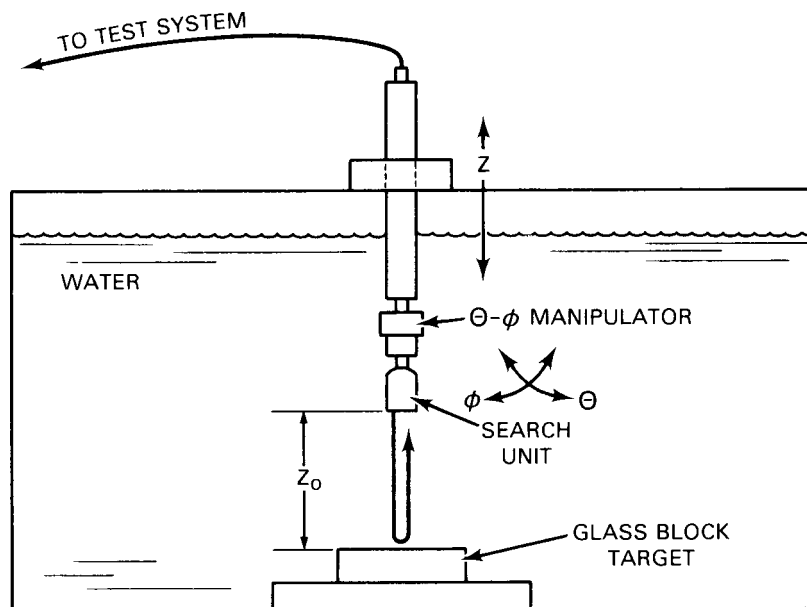

FIG. A1.5 Test Setup for Immersion Search Units

A1.4.1.1 *Flat Search Units*—Flat or nonfocused search units are adjusted so that the distance from the face of the search unit to the target (Z_0) is 2 in. (50 mm). A flat and smooth glass block with dimensions not smaller than 2 by 2 in. (50 by 50 mm) by 1 in. (25 mm) thick is recommended as the target. A manipulator is used to adjust for a maximum amplitude response from the target.

(a) (a) Thinner blocks may be used for higher frequency search units. Thicker blocks may be used for lower frequency or larger diameter search units, or both, as agreed upon by users of this guide.

(b) (b) All targets or test blocks must have a material thickness that is greater than the sinusoidal burst pulse duration of the excitation voltage.

NOTE A1.5—The frequency response of flat search units with bandwidths less than 100 % is essentially independent of the distance from the target. The 2-in. (50-mm) distance is chosen as a compromise to accommodate a variety of frequencies and sizes of search units. Shorter water path distances may be used for high-frequency search units. Distances are to be established by users of the guide. Other materials may be used as reflectors provided material and surface finishes are agreed upon.

A1.4.1.2 *Focused Search Units*—A ball target should be used to obtain the frequency response of focused search units. The ball should have a diameter that is at least 10 wavelengths in water (for example, $\frac{5}{8}$ inch [15 mm] at 1 MHz in water). The

distance Z_0 should be adjusted for maximum amplitude response from the target. Care must be taken to ensure that no internal reflections from the ball or creeping wave signals around the ball are included in the recorded response as these can distort the response.

A1.4.2 *Contact Straight Beam*—Measurements for contact straight-beam search units are made with the unit coupled to the test block. Couplant shall be machine oil or other specified fluid. Fig. A1.6 shows the test setup for contact straight-beam search units. A $1\frac{1}{2}$ -in. (38-mm) flat (32- μ in.) aluminum block, or a block of other suitable material and dimension, may be used for the frequency response measurements. The back surface of the block is used as the target and the echo response from this surface is recorded.

A1.4.2.1 Thinner blocks may be used for higher frequency search units. Thicker blocks may be used for lower frequency or larger diameter search units, or both, as agreed upon by users of this guide.

A1.4.2.2 All targets or test blocks must have a material thickness that is greater than the sinusoidal burst pulse duration of the excitation voltage.

NOTE A1.6—**Caution:** The immersion procedure is *not* valid for evaluating contact straight-beam search units that incorporate a hard wear-face plate.

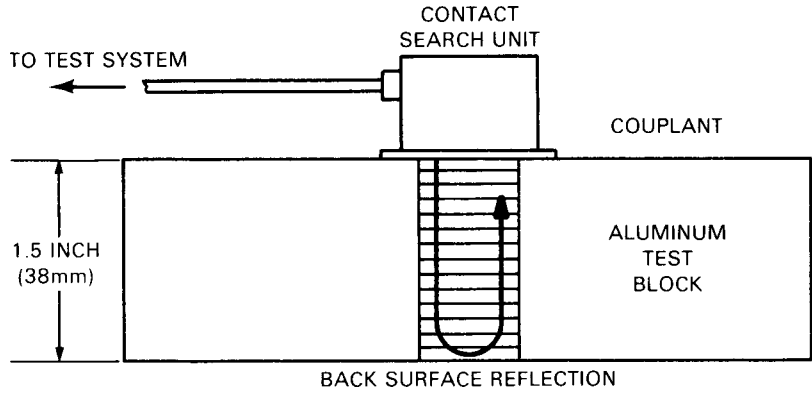

FIG. A1.6 Test Setup for Contact Straight-Beam Search Units

A2. BANDWIDTH MEASUREMENTS

A2.1 The bandwidth (*BW*) (sometimes referred to as functional or operational bandwidth) of a search unit is a selected portion of the frequency response of the search unit.

A2.2 The lower and upper frequency values (f_l and f_u respectively) of the bandwidth are defined as the values at which the amplitude of the pulse-echo response has fallen 6 dB below the peak of the frequency response curve (f_p) (see Fig. A1.1). The peak is chosen as the reference even though it may not be at the center frequency (f_c). Bandwidth measurements are determined by locating the peak response and then selecting the f_l and f_u values.

A2.3 Bandwidth calculations are based on determining the center frequency, f_c , in MHz, of the bandwidth as described as follows:

$$f_c = \frac{f_l + f_u}{2} \tag{A2.1}$$

A2.4 Bandwidth is then calculated as follows:

$$BW = (f_u - f_l)/f_c \times 100 \text{ (percentage)} \tag{A2.2}$$

A2.5 By way of example, the bandwidth for the frequency responses shown in Fig. A1.1 (a) and (b) are as follows:

A2.5.1 *Symmetrical Curve* (Fig. A1.1 (a)):

$$f_c = (4.0 + 6.1)/2 = 5.05 \text{ MHz} \tag{A2.3}$$

$$BW = (6.1 - 4.0)/5.05 \times 100 = 42 \% \tag{A2.4}$$

A2.5.2 *Asymmetrical Curve* (Fig. A1.1 (b)):

$$f_c = (3.4 + 8.2)/2 = 5.8 \text{ MHz} \tag{A2.5}$$

$$BW = (8.2 - 3.4)/5.8 \times 100 = 83 \% \tag{A2.6}$$

A3. RELATIVE PULSE-ECHO SENSITIVITY

A3.1 Relative pulse-echo sensitivity (S_{rel}) is defined as follows:

$$S_{rel} = 20 \log V_e/V_a \text{ (expressed in dB)} \tag{A3.1}$$

where V_e is the peak-to-peak voltage response of the echo from the specific reflector as defined in Annex A1, and V_a is the peak-to-peak voltage applied to the search unit. Both V_a and V_e are measured at the nominal frequency (f_{nom}), as stated by the manufacturer’s label.

A3.1.1 *Sinusoidal Burst Procedure*—Fig. A3.1 describes the data for establishing S_{rel} from the test results obtained with the sinusoidal burst procedure. The value for S_{rel} is established at f_{nom} . In the example shown:

Example A:

$$f_{nom} = f_p \quad V_a = 2.0 \text{ V} \tag{A3.2}$$

$$V_e = 200 \text{ mV}$$

$$S_{rel} = 20 \log (0.2/2.0) = -20 \text{ db}$$

Example B:

$$f_{nom} \neq f_p \quad V_a = 2.0 \text{ V} \tag{A3.3}$$

$$V_e = 0.1 \text{ V}$$

$$S_{rel} = 20 \log (0.1/2.0) = -26 \text{ db}$$

NOTE A3.1—Relative pulse-echo sensitivity measurements may be made with either analog or digitized rf echo waveforms.

NOTE A3.2—No procedure is given in this guide for determining sensitivity using shock excitation procedures.

A3.2 Search unit sensitivity comparisons made with ultrasonic instruments may vary from the values obtained with this procedure and they may vary between types of flaw detectors. Search unit responses are influenced by the impedance of the pulser, impedance of the search unit and coaxial cable, and the input impedance of the receiver.

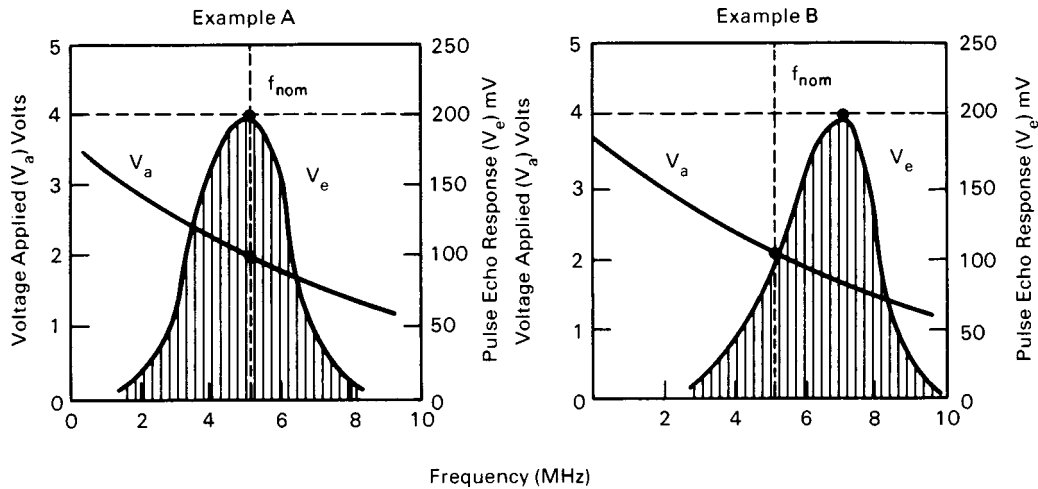

FIG. A3.1 Measurement of Sensitivity from Sinusoidal Burst Frequency Response Curve

A4. MEASUREMENT OF TIME RESPONSE⁵

A4.1 *Time Response*—The time response of a search unit is established from the rf waveform of the echo received from a given target using the pulse-echo procedure. This response is used as the basis for evaluating other operating and recovery parameters of the search unit such as waveform duration and damping (Standard Methods for Testing Single Element Pulse-Echo Ultrasonic Transducers). Typical examples of waveform duration are shown in Fig. A4.1.

A4.2 *Procedure*—The procedure for measuring the time response employs the shock excitation techniques defined in A1.2 and the procedures outlined in A1.4. Fig. A1.2 and Fig. A1.3 illustrate the setup for pulse-echo procedure. Fig. A1.5 and Fig. A1.6 illustrate the test configuration for immersion and contact straight-beam search units.

A4.3 *Time Response Terms and Parameters*—A photograph or printout of the rf waveform from the CRT can be used to described the time response of the search unit. This record should provide a scaled time base from which the measurement can be defined. Examples are shown in Fig. 1 and Fig. 2. The

terms and parameters selected in the quantitative description of waveforms (for example, waveform duration, resolution, and damping) should be defined and agreed upon by users of this guide. Waveform duration may be measured as a level either 20 or 40 dB below the peak of the pulse-echo response. As the time response can be influenced by the input electronics and impedance of the receiver, care must be taken to ensure that the receiver input is not saturated and that the impedance is high enough (for example, 500 ohms or greater) to accurately record the echo signal.

NOTE A4.1—This guide does not describe a procedure for obtaining “time response” using the sinusoidal burst excitation procedure.

NOTE A4.2—For accurate measurement of the time response of a digitized rf waveform, an 8-bit digitizer is needed. A sufficient number of samples per cycle should be taken that a curve through the sampled values provides a smooth waveform that resembles the original analog waveform. For reliable measurement of peak or low-level waveforms, a minimum sampling of 36 samples per cycle is recommended. An 8-bit digitizer is inherently limited to displaying 48 dB of dynamic range and only half of this range is usable for evaluating an rf waveform, to evaluate low level signals may require increasing the gain of the amplifier. Averaging a number of waveforms increases the reliability. Specific requirements may be established between the supplier and user.

⁵ See AIUM Standard Methods (2.2).

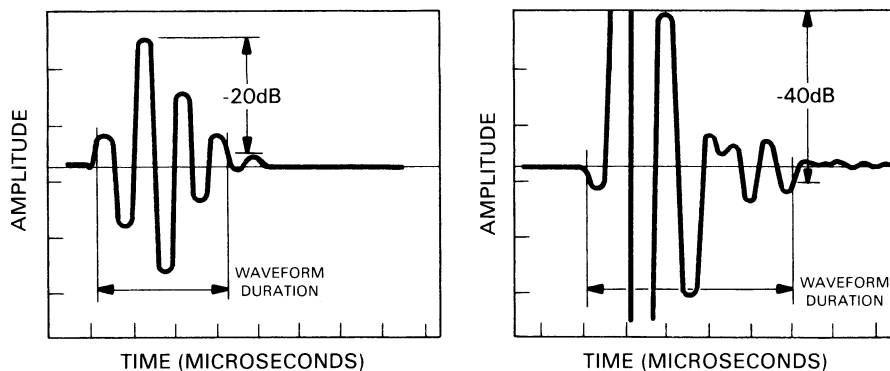

FIG. A4.1 Time Responses (Waveform Duration)

A5. ELECTRICAL IMPEDANCE MEASUREMENTS

A5.1 The magnitude and phase of the electrical impedance of a search unit may be determined using an impedance meter. The magnitude of the electrical impedance of the search unit may be determined using the sinusoidal burst technique and measuring the voltage and current applied to the search unit.

A5.1.1 *Electrical Impedance to be Measured with an Impedance Meter*—Refer to the instruction manual for the impedance meter being used for procedures to obtain the magnitude and phase angle of the complex impedance of the unit being measured.

A5.1.2 *Electrical Impedance to be Measured with Sinusoidal Burst Technique*—Fig. A1.4 describes the block diagram used for measuring the frequency response of a search unit. The same electrical setup may be used for measuring the magnitude of the electrical impedance of the search unit. The voltage probe provides a measurement of the applied voltage as a function of frequency. The current probe provides a measure-

ment of the applied current as a function of frequency. The value for the magnitude of the electrical impedance is determined at the nominal frequency of the search unit (f_{nom}).

$$|Z| = V_a/I_a \quad (\text{A5.1})$$

where V_a is the applied voltage and I_a is the applied current at f_{nom} . Fig. A5.1 shows a sketch of the responses from which the impedance measurements are measured. For using the sinusoidal burst technique, measurements shall be made with a coaxial cable attached to the search unit. For purposes of this guide, a 4 ft long cable is recommended.

NOTE A5.1—All impedance measurements are to be made under conditions that apply appropriate loading to the face of the search unit. As examples, immersion units should be measured in water; contact units should be coupled to a metal block. Precautions should be made to ensure that no standing wave interference occurs in the water tank or test block.

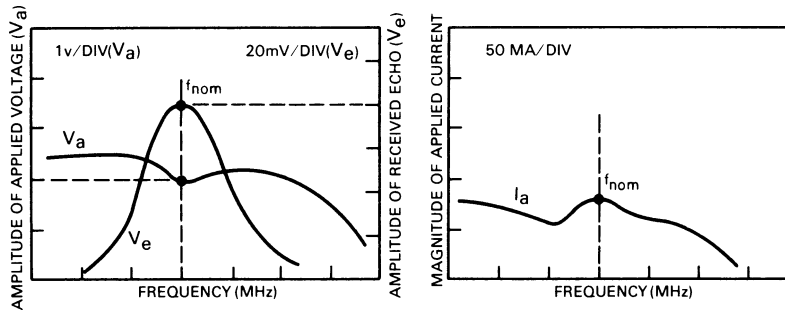

FIG. A5.1 Typical Voltage and Current Recordings for Determining Magnitude of Search Unit Impedance

A6. MEASUREMENT OF SOUND FIELD PARAMETERS

A6.1 Introduction—This section describes procedures for measuring sound field parameters of immersion flat and focused search units. Either analog or digital equipment may be used.

A6.2 Test Setup—This procedure outlines a means for employing a pulse-echo technique using a ball target reflector. A second procedure using a hydrophone receiver is also described. For purposes of this guide, the transmission pattern and the reception patterns of search units are considered identical and reciprocal. The search unit may be excited with a shock excitation pulse or with a sinusoidal burst at center frequency, f_c .

A6.2.1 For users of the guide, the test setup for pulse-echo measurements is shown in Fig. A6.1. The test setup for hydrophone measurements is shown in Fig. A6.2. The setup includes a pulse generator, preamplifier, echo gate that can be adjusted to capture the echo, search unit, target or hydrophone, a peak detector, and a XY recorder. The peak detector output is the Y-axis input. The X-axis input is the analog output from the

X-Y-Z manipulator of the bridge carriage and immersion tank scanning and indexing equipment.

A6.2.2 Ball Target— The ball target chosen for the pulse-echo procedure should be a small smooth sphere (for example, a diameter equal to 10 wavelengths (λ) in water).

A6.2.3 Hydrophone— Two types of hydrophones may be employed. The most desirable is the hydrophone that has an active element with a diameter less than 2λ of the center frequency, f_c , of the search unit as measured in water. If the element is larger than this dimension, a correction factor must be added to include the directivity function of the hydrophone. Frequency response of the hydrophone must be sufficiently broad so that no adverse response is introduced by the hydrophone. A hydrophone may be a miniature search unit with a small piezoelectric element or may be constructed using appropriate commercial immersion search units by attaching a sound-absorbing mask (for example, cork) which has a small center pinhole to the face of the search unit. Fig. A6.3 describes the hydrophone with the sound-absorbing mask.

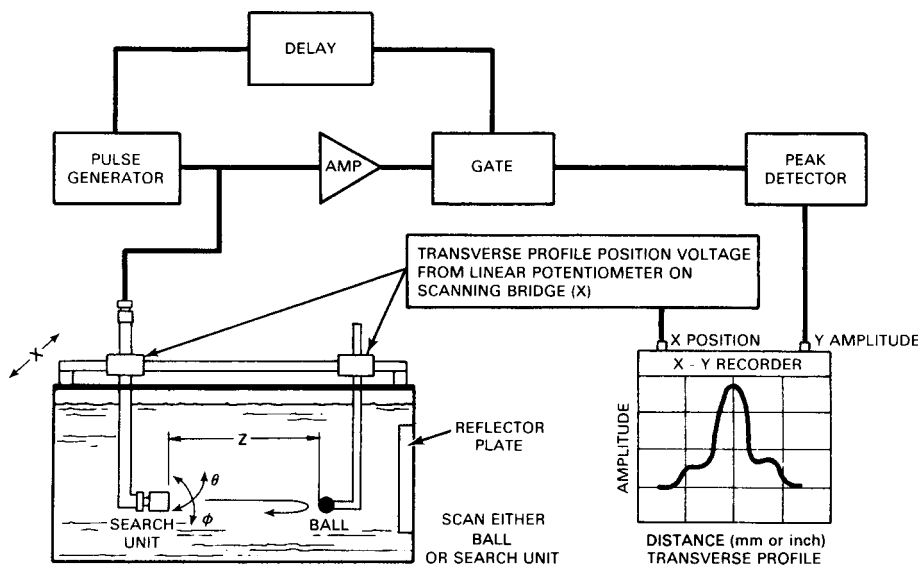

FIG. A6.1 Test Setup for Measuring Sound Field Patterns with Pulse-Echo Technique Using Ball Target Reflector

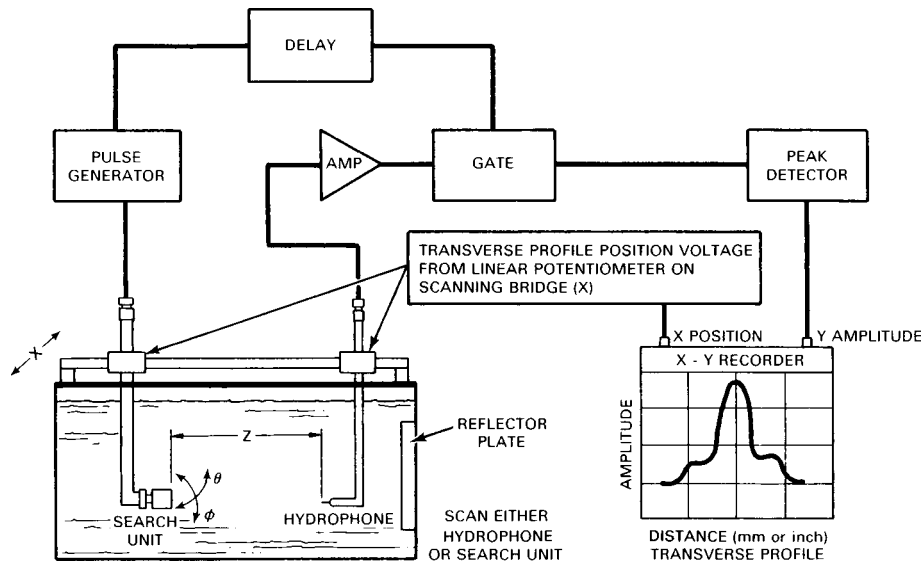

FIG. A6.2 Test Setup for Measuring Sound Field Patterns Using Hydrophone Procedure

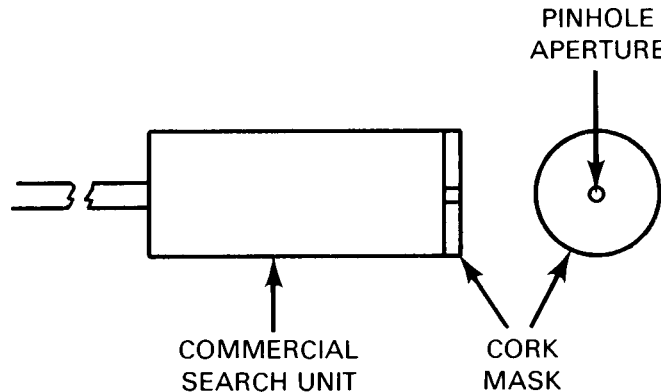

FIG. A6.3 Cork Mask for Adapting Commercial Search Units to Small Hydrophone

A6.3 Immersion Flat (Nonfocused) Search Units—Four parameters are identified as important for evaluating the characteristics of immersion flat search units: (a) aperture size, (b) traverse profile, (c) on-axis profile, and (d) sound beam spread.

A6.3.1 Ball Target Measurements:

A6.3.1.1 The sketch in Fig. A6.1 shows a setup for obtaining sound-field parameters using the pulse-echo reflection from a ball target reflector. As the sound beam transmitted from the search unit is assumed to be identical to the sound beam pattern of the search unit in a receiving mode, the pulse-echo response is the product of the two sound beams. Accordingly, various parameters such as aperture size and sound beam spread are measured to different levels on the response curve depending on the technique employed. As an example, when using the ball target, pulse-echo technique, measurements are made to a level that is -6 dB below the peak of the response. With use of the hydrophone technique, the measurements are made to a level that is -3 dB below peak of the response. Commercial systems are available for making such measurements.

A6.3.1.2 An example of the procedure for obtaining sound beam parameters using ball target measurements is as follows (see Fig. A6.1):

(a) Place a flat target that is perpendicular to the bridge carriage in the tank and adjust the θ and ϕ axis of the manipulator holding the search unit to obtain maximum pulse-echo response from the target.

(b) Place the ball target in the tank at a fixed location and position the search unit so that it is located at a distance that is in the far field (beyond peak response for focused units). Adjust the X-Y-Z manipulator to obtain maximum response from the ball target. (Alternatively, the search unit may be fixed and the ball target moved.)

A6.3.1.3 Aperture Size— To obtain aperture size (see Fig. A6.4 (c) Position 1), move the search unit close to the ball target (for example, $\frac{1}{16}$ in. (1.5 mm)) and scan the target. Care must be exercised to ensure that the echo in the gate contains only the energy from the ball target. The aperture size is defined as the dimension of the pressure pattern as measured to the -6 dB level below the average response across the center portion of the search unit.

A6.3.1.4 Transverse Profiles—Transverse profiles are obtained by scanning the ball target through the sound beam at selected distances away from the face of the search unit (see Fig. A6.4). Selection of theoretical positions such as the near-far-field transition, Z_n , or other points such as $Z_n/2$, $Z_n/3$,

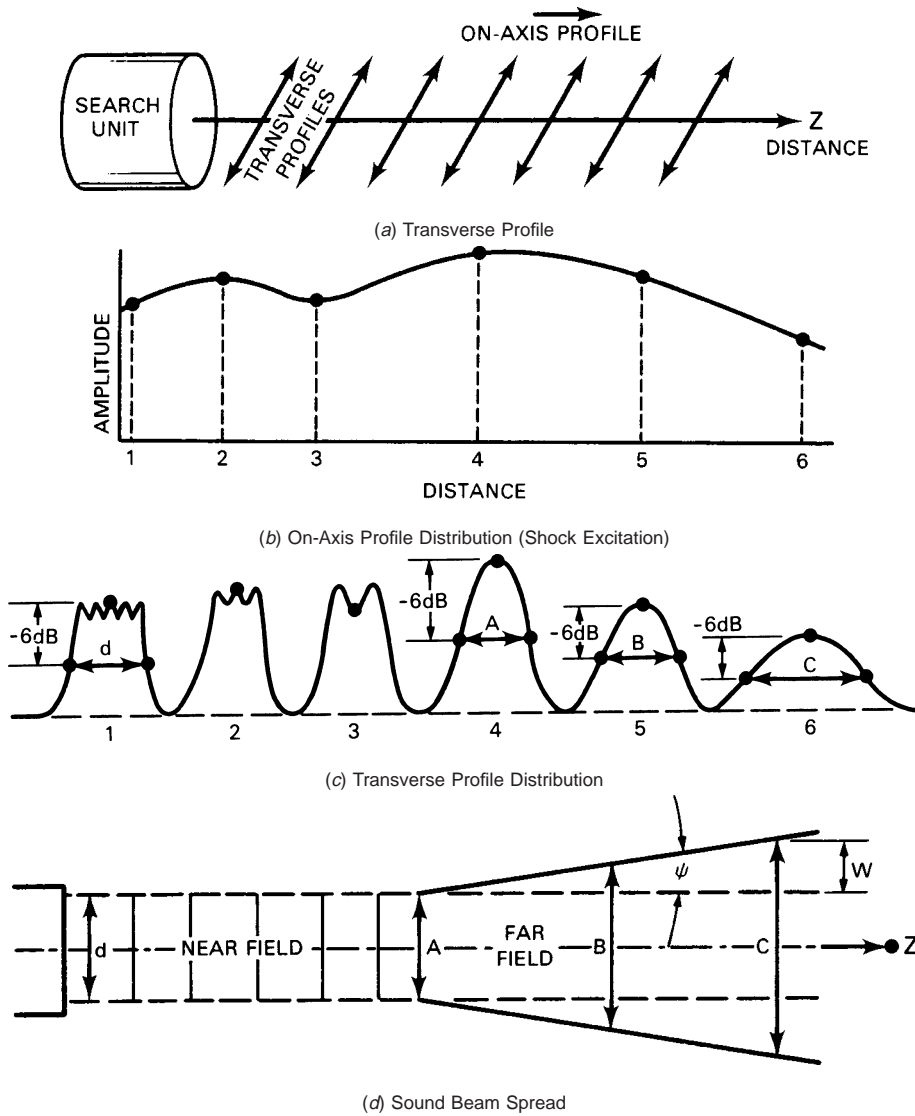

FIG. A6.4 Sound Field Patterns for Establishing Search Unit Performance Parameters

or $2Z_n$, may be appropriate if a sinusoidal burst excitation is employed. For shock excitation, it may be more appropriate to use specific distances (for example, 1, 3, 5, etc. in (25, 75, 125, etc. mm)). For reference purposes, the near-far-field transitions for various aperture sizes may be calculated from the following:

$$\text{Circular Piston, } Z_n = d^2 / 4\lambda \quad (\text{A6.1})$$

where:

- Z_n = distance from search unit face to far field transition,
- λ = wavelength, and
- d = aperture.

$$\text{Square element (A} \times \text{A Dimension)} \quad (\text{A6.2})$$

$$Z_n = 1.35 A^2 / 4\lambda$$

(See Ref (3).)

To establish beam patterns or beam symmetry, the beam should be plotted in two orthogonal directions at the near-far field transition or other selected distances, or both, as agreed by the users.

A6.3.1.5 On-Axis Profiles—On-axis profile is obtained from the transverse profile by recording the amplitude of the center of the transverse plots as a function of distance, Z , from the face of the search unit (see Fig. A6.4). Alternatively, if the center of the beam can be established, the ball target may be moved along the axis of the beam and record the on-axis pressure response as a function of distance. This procedure is more difficult as it is hard to maintain the central axis of the beam as the ball target is moved away from the face of the search unit.

A6.3.1.6 *Beam Spread*— Beam spread is a measure of the beam divergence as a function of distance beyond the near-far field transition (see Fig. A6.4). Beam spread may be determined from the transverse plots or by measuring the sound field pattern at two or more locations in the far field. The procedure is to establish the width of the sound beam at a specific dB value below peak response at that position. For ball target measurements, the responses are measured to a level -6 dB below peak response. The beam spread (2ψ) is then calculated as follows:

$$2\psi = 2 \text{Arctan } W/(Z_c - Z_a) \quad (\text{A6.3})$$

(See Fig. A6.4.)

where:

Z_a = distance beyond the near-far field transition,

Z_c = selected distance beyond Z_a , and

W = measured increase in sound field width.

A6.3.2 *Hydrophone Measurements*—Fig. A6.4 shows sketches of typical results for flat immersion search units. A procedure for obtaining these parameters with hydrophone measurements is as follows (see Fig. A6.2):

(a) (a) Place a flat target that is perpendicular to the bridge carriage in the tank and adjust the ϕ and θ axis of the manipulator holding the search unit to obtain maximum pulse-echo response from the target. This ensures that scanning and indexing will be normal and parallel to the axis of the sound field.

(b) (b) Place the hydrophone on the scanning bridge and center the hydrophone by placing it in the far field and adjust the hydrophone to obtain maximum or peak response (alternatively, the hydrophone may be fixed and the search unit moved).

A6.3.2.1 *Aperture Size*— To obtain aperture size, move the hydrophone close to the face of the search unit (for example, $1/16$ in. (1.5 mm)) and scan the beam. The aperture size of the sound beam is defined as the dimension of the pressure pattern as measured to the -3 dB level below the average response across the center portion of the search unit minus the radius of the hydrophone. See Fig. A6.4(c), Position 1.

A6.3.2.2 *Transverse Profiles*—Transverse profiles are obtained by recording the response from the hydrophone as

measured at selected distances away from the face of the search unit. The same conditions apply to hydrophone measurements as applied for the ball target measurements (see A6.3.1.4).

A6.3.2.3 *On-Axis Profiles*—On-axis profiles are obtained in a manner similar to that followed for ball target measurements (see A6.3.1.5). As with other hydrophone measurements, care must be taken to ensure that the response from the hydrophone falls within the gate. (Assuming a gated receiver is used.)

A6.3.2.4 *Beam Spread*— Beam spread is measured in the same manner as described for the ball target measurements (see A6.3.1.6). The basic difference is that beam spread is measured at a level of -3 dB below the peak response obtained at the position measured instead of the 6 dB level as followed for the ball target measurements.

A6.4 *Focused Immersion Search Units*—For focused immersion search units the parameters to be measured include aperture size (d), focal length (F_L), depth of field (F_D), and sound beam diameter at the peak response (d_{FL}).

A6.4.1 *Focal Length and Depth of Field*—Fig. A6.5 describes the on-axis plot of the sound field of a focused search unit. A ball target is used to obtain values for peak response (F_p), and depth of field (F_D). Once the maximum amplitude response is obtained from the target, the search unit is moved toward the target until the amplitude drops 6 dB (50 %) below the peak. This distance is noted as the lower position of the depth of field. The search unit is then moved through the peak and beyond until the amplitude drops 6 dB below the peak. The distance between these two positions (F_1 through F_2) defines the depth of field (F_D) of focused search units. When making these measurements, care must be taken to ensure that the target remains directly on the axis of the search unit. Misalignment can result in erroneous measurements.

A6.4.1.1 The depth of field is defined as the distance $F_2 - F_1$. The values for F_1 and F_2 may be obtained using a pulse-echo response from a ball target reflector or in a transmission mode using the hydrophone technique. However, if the hydrophone technique is used, the depth of field, F_D , is measured to the -3 dB below the amplitude at peak response instead of -6 dB below the amplitude at peak response as used in pulse-echo procedures.

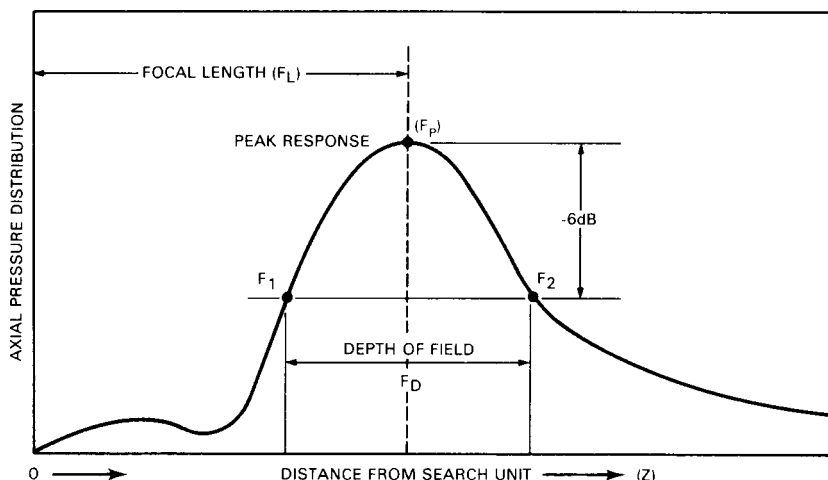

FIG. A6.5 On-Axis Profile Parameters from Focused Search Unit

A6.4.2 *Diameter at Focal Point*—The diameter at the focal point, d_{FP} , of a search unit may be obtained using either the pulse-echo response from a ball target or by using the hydrophone technique. The initial step in this procedure is to locate the focal peak. After the peak is located, a cross-axial plot provides the diameter at the focal point. When using the pulse-echo, ball target technique, the diameter at the focal point is defined as the width of the sound beam measured to the -6 dB level. When the hydrophone technique is used, the diameter at the focal point is defined as the width of the sound beam measured to the -3 dB level. Fig. A6.6 shows typical patterns obtained with this procedure.

A6.4.3 *Transverse Profiles for Focused Search Units*—Transverse profiles are obtained by scanning the ball target through the sound beam at selected distances from the face of the search unit. Profiles made at the search unit’s focal point provide information relating to the diameter of the beam.

A6.4.3.1 *Beam Symmetry*— To establish the sound beam symmetry, transverse profiles should be plotted in two orthogonal directions at the distance corresponding to the focal length. Such profiles are commonly called the *X* and *Y* beam profiles.

A6.5 *Measurement of the Included Angle of the Beam from a Focused Immersion Search Unit:*

A6.5.1 *Introduction*—Knowledge of the included angle of the beam from a focused search unit, measured as described in this section, is of importance in determining examination coverage, especially in cylindrical material (9), and in predicting the degree of linearity of signal amplitude versus target area to be expected with various combinations of examination parameters (10).

A6.5.1.1 The purpose of this section is to provide a common procedure for measuring the effective included beam angle of focused sound fields and to define common parameters for making the measurements.

A6.5.1.2 The included beam angle measurement described herein is based on transverse beam profile measurements made on either spherically or cylindrically focused search units. The on-axis and transverse profiles of a spherically focused search unit are essentially identical to those shown in Fig. A6.4(b) and Fig. A6.4(c) for a “flat” search unit, except that the distances

are decreased by the focusing means. The point of maximum on-axis amplitude may be taken to represent the focal length (FL) of the unit. A thin wire target may be used as an alternative to the ball target described in A6.2 and A6.3. This offers certain advantages in set-up simplicity, signal strength, and reproducibility (11).

A6.5.2 *Geometrical Beam Representation*—A simple representation of a cross section of the near field of a focused beam is shown in Fig. A6.7. This represents any cross section of a spherically focused beam. For a cylindrically focused beam it represents a cross section in the transverse (width) direction only. Some previous attempts at defining a beam included angle have considered only the geometrical factors shown in the figure. When this is done the included angle might be erroneously expressed approximately by the following equation derived from the figure.

$$\alpha \approx 2 \tan^{-1} \frac{W/2}{FL} \tag{A6.4}$$

where:

- α = beam included angle,
- W = search unit element diameter (or width), and
- FL = focal length of search unit.

A6.5.2.1 This simple approach does not take into account the decrease in pressure amplitude from beam center to edges of a transmitting focused search unit, nor the corresponding reduction in sensitivity from beam center to edges of a receiving search unit. When the pulse-echo examination technique is employed both sources of decreasing off-center response act to cause the effective angular width of the beam to be smaller than would be obtained from the previous equation. For this reason, although the beam representation of Fig. A6.7 is useful in visualizing the convergence of a focused beam, it is not recommended that quantitative calculations be based on it.

A6.5.2.2 *Transverse Beam Profiles*—Fig. A6.6 shows the transverse profile of a spherically focused beam at the focal distance from the search unit. A cylindrically focused beam also has a profile like this when taken in the “width” direction, that is, perpendicular to the “beam length” direction. However when the profile of a cylindrically focused search unit is

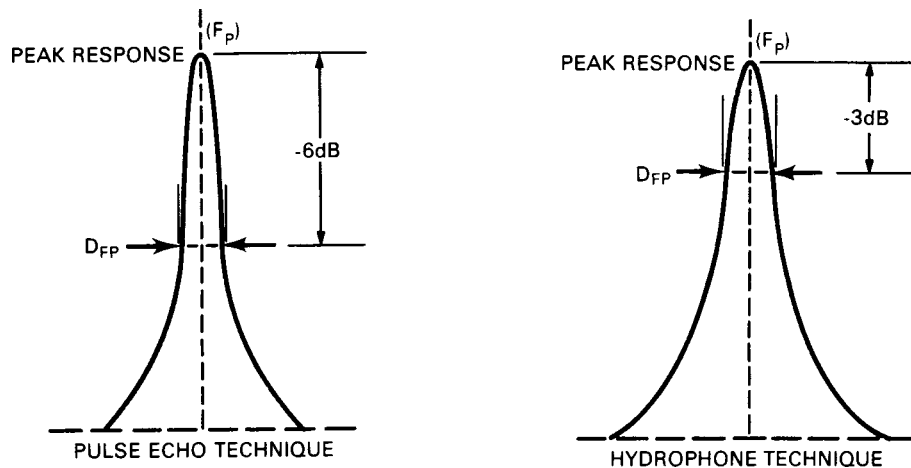

FIG. A6.6 Measurement of Sound Beam Diameter of Focused Search Unit

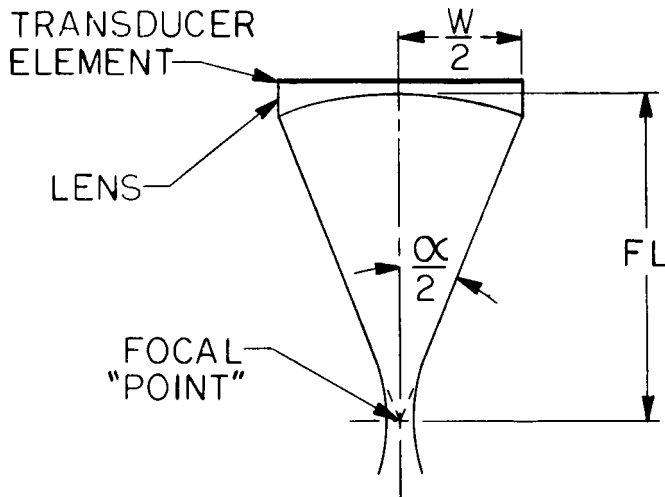

FIG. A6.7 Cross Section of a Focused Beam

$$\alpha = 2 \tan^{-1} \frac{PW_{FL/2} - PW_{FL}}{FL} \quad (A6.5)$$

where:

$PW_{FL/2}$ = -6 dB profile width at half focal length, and

PW_{FL} = -6 dB profile width at focal length.

A6.5.3.1 Procedure—An example of a detailed procedure for making measurements for use in the above equation is as follows:

(a) (a) If the focal length of the search unit is not known, it is measured in the pulse-echo mode as described in A6.4.1 using either a ball target, or preferably for cylindrically focused units, a small diameter wire (11).

(b) (b) Transverse profiles are measured in water in the pulse-echo mode as described in A6.4.3 at water path distances from search unit face to target equal to the focal length and to half that length. The peak amplitude of the response at each distance is set on the display to a convenient, high percentage of full screen height (FSH) which is below the vertical linearity limit of the instrument (for example, 80 % FSH). More gain will be required to achieve this level for the profile at half focal length because of the reduced beam pressure at this distance. The width of the profile at an amplitude of 50 % (-6 dB) of the peak value (for example, 40 % FSH) is to be recorded for each profile.

(c) (c) The -6 dB profile widths measured in (b) are then used in the above equation as PW_{FL} and $PW_{FL/2}$ to calculate the value of the beam included angle, α .

A6.5.4 Comparison Example of Beam Angle Determined from Profiles and from Search Unit Geometry—An example is given below of calculations of α for a typical search unit by both the “geometrical” equation first given above and by the more accurate second equation that uses measured profile widths.

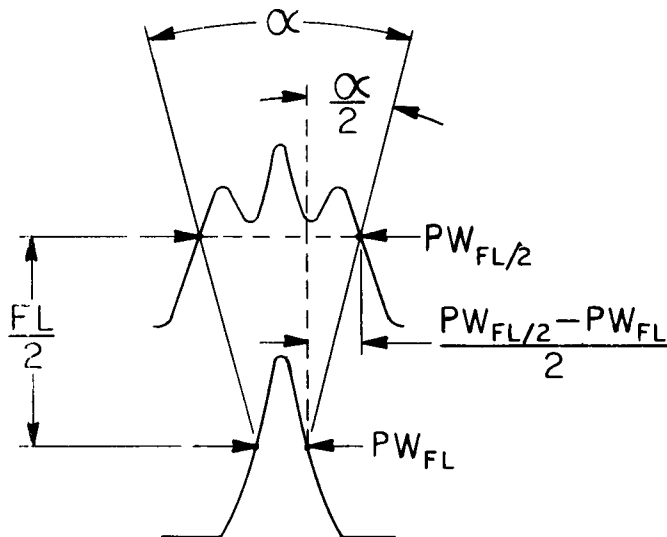

FIG. A6.8 Determination of Included Angle from Transverse Beam Profiles

Search Unit Characteristics

Frequency	5.0 MHz
Diameter	0.5 in.
Focal Length	2.05 in.
Measured $PW_{FL/2}$	0.169 in. (at -6 dB)
Measured PW_{FL}	0.031 in. (at -6 dB)

A6.5.4.1 Calculation From Search Unit “Geometry”:

$$\alpha = 2 \tan^{-1} \frac{0.5/2}{2.05} = 2 \tan^{-1} 0.122 = 13.9^\circ \quad (A6.6)$$

A6.5.4.2 Calculation From Measured Profile Widths:

$$\alpha = 2 \tan^{-1} \frac{0.169 - 0.031}{2.05} = 2 \tan^{-1} 0.067 = 7.7^\circ \quad (A6.7)$$

A6.5.4.3 The significantly lower value of beam included angle obtained from the second calculation is much more in line with values of this angle successfully used when comparing calculated and measured results of beam coverage and area-amplitude linearity with similar search units in studies based on Refs (9) and (10).

A7. SPECIAL TECHNIQUES FOR HIGH-FREQUENCY BROADBAND IMMERSION SEARCH UNITS

A7.1 Introduction—At high frequencies, water significantly attenuates ultrasound and may cause a measurable downshift of the return echo peak frequency for broadband immersion search units. The frequency downshift may also shorten the measured focal length of focused search units. This Annex provides approximate methods for calculating the effect of attenuation on the operating characteristics of immersion search units, provides a sample guideline table of maximum water paths for various frequency and bandwidth search units, and suggests techniques for characterizing the frequency and focus of high-frequency broadband immersion search units.

A7.1.1 Attenuation causes the decrease in measured signal amplitude with increasing propagation distance in the sound transmitting material, and is a function of frequency. Neglecting other losses such as diffraction, amplitude can be expressed as an exponential equation of the form:

$$A = A_o e^{-\alpha f^n Z} \tag{A7.1}$$

where:

- Z = propagation distance in cm,
- f = frequency in Hz,
- n = exponent of frequency dependence,
- α = frequency dependent amplitude attenuation coefficient of the medium in nepers/cm/Hzⁿ,
- A_o = unattenuated amplitude,
- A = attenuated amplitude, and
- e = 2.71828...

NOTE A7.1—Attenuation in terms of dB/cm at a specific frequency is obtained from

$$\text{dB/cm} = -8.6859 \alpha f^n \tag{A7.2}$$

A7.2 Theory:

A7.2.1 An approximate expression for the downshifted peak frequency when the exponent of frequency dependence is n = 2, as in water, is given by Ophir and Jaeger: (4)

$$f_p = \frac{f_o}{2\alpha Z \sigma^2 + 1} \tag{A7.3}$$

where:

- f_o = unattenuated peak frequency in Hz,
- α = amplitude attenuation coefficient in nepers/cm/Hz²,
- Z = propagation distance in cm,
- σ = (f_o × % BW/236), and
- % BW = percent bandwidth (−6dB) of the unattenuated spectrum.

NOTE A7.2—Propagation distance is the round trip distance from the search unit to the target and back to the search unit, and bandwidth refers to the double transduction pulse-echo spectrum under shock excitation.

NOTE A7.3—Attenuation in terms of dB/cm/MHz² is obtained from

$$\text{dB/cm/MHz}^2 = -8.6859 \times 10^{12} \alpha \tag{A7.4}$$

A7.2.1.1 Using (Eq 3), the round trip water path that causes a 5 % peak frequency downshift in water is:

$$Z = \frac{1465}{\alpha f_o^2 (\% BW)^2} \tag{A7.5}$$

A sample calculation for water is:

- α = 36 × 10^{−17} neper/cm/Hz²,
- f_o = 25 × 10⁶ Hz,
- % BW = 50 %, and
- Z = 2.6 cm (1.02 in.)

A7.2.1.2 The sample guidelines of Table A7.1 have been calculated in this manner. The table shows the round trip water path that is expected to produce a 5 % downshift in peak frequency for various bandwidth and unattenuated peak frequency search units for this assumed attenuation coefficient. Actual attenuation coefficients depend on water temperature and purity.

NOTE A7.4—Calculations can use decibels/cm/MHz² for the attenuation coefficient, and MHz for frequency if (Eq. 5) is multiplied by −8.6859. Then

$$Z = \frac{-1.273 \times 10^4}{(\text{dB/cm/MHz}^2)(\text{MHz})^2(\% BW)^2} \tag{A7.6}$$

and the sample calculation for water becomes:

dB/cm/MHz² = −3.127 × 10^{−3} (See Note A7.5.)

- MHz = 25,
- % BW = 50 %, and
- Z = 2.6 cm (1.02 in.).

NOTE A7.5—The coefficient 3.127 × 10^{−3} was experimentally derived from studies of frequency shift data. Other values have been noted. [See for example, Refs (5-8).]

A7.3 Methods—The greater the bandwidth at a given frequency, the shorter the permissible water path. If the

TABLE A7.1 Sample Guideline: Total Maximum Water Path (cm (in.)) Resulting in 5 % Peak Frequency Downshift^A

MHz	Bandwidth							
	30 %	40 %	50 %	60 %	70 %	80 %	90 %	100 %
	cm (in.)							
3.5					67.8	51.9	41.0	33.2
					26.7	20.4	16.2	13.1
5.0			65.1	45.2	33.2	25.4	20.1	16.3
			25.6	17.8	13.1	10.0	7.9	6.4
7.5		45.2	28.9	20.1	14.8	11.3	8.9	7.2
		17.8	11.4	7.9	5.8	4.5	3.5	2.8
10.0	45.2	25.4	16.3	11.3	8.3	6.4	5.0	4.07
	17.8	10.0	6.4	4.5	3.3	2.5	2.0	1.60
15.0	20.1	11.3	7.2	5.0	3.69	2.83	2.23	1.81
	7.9	4.5	2.8	2.0	1.45	1.11	0.88	0.71
20.0	11.3	6.4	4.07	2.83	2.08	1.59	1.26	1.02
			1.60	1.11	0.82	0.63	0.49	0.40
25.0	4.5	2.5						
	7.2	4.07	2.61	1.81	1.33	1.02	0.80	0.65
	2.8	1.60	1.03	0.71	0.52	0.40	0.32	0.26
30.0	5.0	2.83	1.81	1.26	0.92	0.71	0.558	0.452
	2.0	1.11	0.71	0.49	0.36	0.28	0.220	0.178
40.0	2.83	1.59	1.02	0.71	0.519	0.398	0.314	0.254
	1.11	0.63	0.40	0.28	0.204	0.157	0.124	0.100
	1.81	1.02	0.65	0.452	0.332	0.254	0.201	0.163
50.0	0.71	0.40	0.26	0.178	0.131	0.100	0.079	0.064

^ALeaders signify > 76 cm (30 in.). Divide indicated water paths by 2 to get one way distance in water (distance between search unit and target). Calculated for α = −3.127 × 10^{−3} dB/cm/MHz².

combination of center frequency, bandwidth and focal length are beyond the limits indicated in a guideline table such as Table A7.1, the focal length and frequency response should be determined by other methods such as those schematically presented in Fig. A7.1.

A7.3.1 The principle shown in insets *a*, *b*, *c*, and *d* of Fig. A7.1 is to replace water with a high-velocity, low-attenuation second material such as fused silica. This shortens the sound travel distance through water. The acoustic axis of the beam of the search unit is directed at normal incidence to the second material.

A7.3.1.1 *Focal Length*—The methods shown in insets *a*, *b*, and *c* of Fig. A7.1 are approaches that could approximately measure ball target focal length as defined in 3.2.5 and 3.2.6 of this guide.

(a) Inset *a* uses a ball target in water. The second material merely displaces some of the water between the search unit and the ball.

(b) Inset *b* uses a spherical reflector embedded in the second material. An example would be a bubble inside fused silica.

(c) Inset *c* uses a hemispherical target ground into the backwall of the high-velocity, low-attenuation second material.

NOTE A7.6—Focal length measurement is based on the maximum positive or negative (whichever is larger) peak half cycle amplitude in pulse-echo operation off a reflecting target. The result obtained with a planar reflector is the flat plate focus. The result obtained with a spherical reflector is the ball target focus. The two results are necessarily different.

A7.3.1.2 *Frequency Response*—The method shown in inset *d* of Fig. A7.1 maximizes the backwall echo and approximates

the frequency response measurement conditions (See A1.4.1.2). The schematic representation of the sound field in inset *d* is intended to emphasize that the sound path length determined by this method is different from the ball target focal length defined in 3.5 and 3.6. The ratio between the sound path length for maximum pulse-echo amplitude from a ball target and that from a flat plate target is graphed in Fig. A7.2.

A7.3.2 *Focal Length and Frequency Response*—The principal shown in inset *e* of Fig. A7.1 has been applied to high-frequency focused immersion delay line search units, such as 50 MHz, 0.635 cm (0.25 in.) diameter $F_L = 1.27$ cm (0.5 in.) to measure both focal length and frequency response. The method assumes a spherical wave front and uses the surface of a ball as an equal phase reflector to shorten the water path. The focal point (F_p) is inferred to be at the geometric center of the ball. The method of adding half of the ball diameter to the one way water path is not directly applicable to situations where the focal length is diffraction limited.

A7.4 *Calculations*—Calculations are illustrated for the frequency response method schematically illustrated in inset *d* of Fig. A7.1. Similar calculations would apply to insets *a*, *b*, and *c* of Fig. A7.1. The partitioning of the sound path when it is to be comprised of two materials of different sound velocities, such as water and fused silica, is calculated from:

$$Z_{TM} = [Z'_F - Z_W] \left(\frac{C_W}{C_{TM}} \right) \quad (A7.7)$$

$$Z_W = Z'_F - Z_{TM} \left(\frac{C_{TM}}{C_W} \right) \quad (A7.8)$$

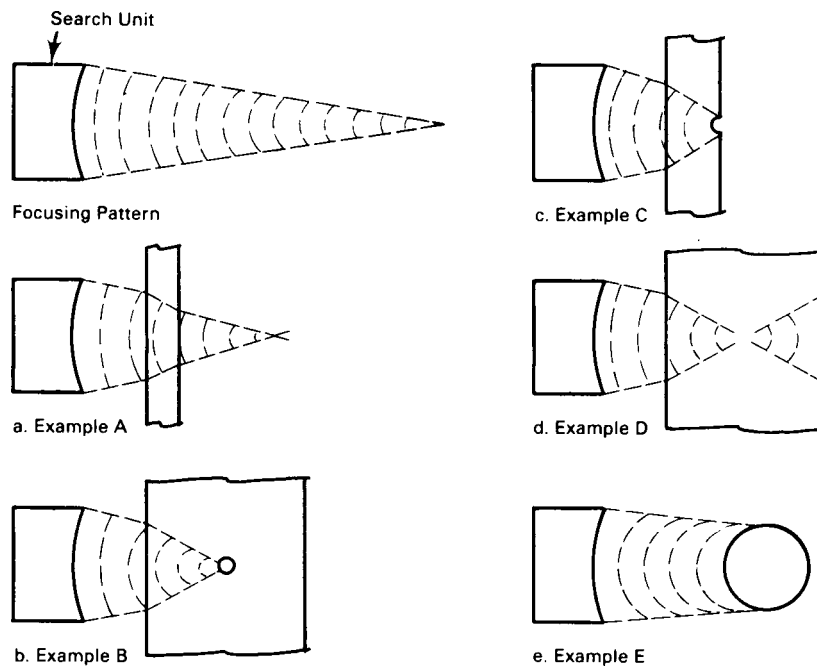

FIG. A7.1 Focal Length Measurements

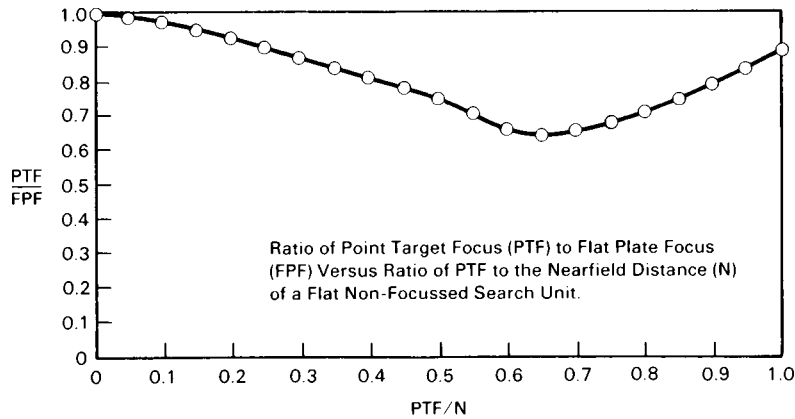

FIG. A7.2 Ratio of Point Target to Flat Plate Focus

where:

Z'_F = theoretical flat plate maximum (distance for maximum echo amplitude from a flat plate in water in the absence of frequency downshift),

Z_W = one way water path between the search unit and the entry surface of the second material of lower attenuation,

Z_{TM} = thickness of the second material (in this case the thickness that maximizes the backwall echo),

C_W = speed of sound in water, and

C_{TM} = speed of sound in the second material

Example—Design frequency response measurement conditions for a 10-MHz search unit with 80 % bandwidth and a theoretical flat plate maximum of 10.0 cm. Table A7.1 suggests that the maximum round trip water path should be less than 5.1 cm (2 in.). Assume that the second material is fused silica with $C_{TM} = 0.594$ cm/ μ s, and that $C_W = 0.148$ cm/ μ sec. With $Z'_F = 1.0$ cm, and $Z_W \leq 2.5$ cm, then

$$Z_{TM} = [100 - 25] \left(\frac{1.48}{5.94} \right) = 1.87 \text{ cm (0.74 in.)} \quad (A7.9)$$

Suppose that a 2.0 cm (0.79 in.) thick piece of fused silica were available. The one-way water path is then predicted to be

$$Z_W = [100 - 2.0] \left(\frac{5.94}{1.48} \right) = 1.97 \text{ cm (0.078 in.)} \quad (A7.10)$$

Accordingly the maximum echo amplitude from the back side of a 2.0 cm thick fused silica plate should occur with a 1.97 cm water path and the frequency response should peak at 10 MHz within normal tolerances.

A7.5 Reports—The search unit characterization report should record the one-way water path to the second material, record the type and thickness of the second material, and state the type of reflector used. For focal length measurements that use a second material to displace water, calculate the equivalent focal length in water from

$$F_L = Z_W + Z_{TM} \left(\frac{C_{TM}}{C_W} \right) \quad (A7.11)$$

Example—A one-way water path of 2.2 cm maximizes the echo from a bubble located 1.9 cm from the entry surface in a plate of fused silica. The equivalent focal length in water is

$$F_L = 2.2 + (1.9) \left(\frac{5.94}{1.48} \right) = 9.83 \text{ cm (3.87 in.)} \quad (A7.12)$$

A8. Measurement of Sound Beam Patterns in Metal from Ultrasonic Straight-Beam, Contact Search Units

A8.1 Introduction—The sound field patterns that propagate from ultrasonic straight-beam, contact search units vary with frequency, size, shape, and design. These search units may be designed with single or dual, circular or rectangular piezoelectric elements and configured to propagate columnar, divergent, or focused beam patterns. Measuring the beam pattern in metal from ultrasonic search units is important in establishing parameters such as beam spread (or focus) and ultrasonic response (echo amplitude) from targets at different depths. These parameters are valuable in selecting a search unit for specific applications and analyzing the received data.

A8.1.1 —Annex A8 describes a means for measuring sound beam patterns in metal using the pulse-echo response from a series of side-drilled holes (SDHs) machined at different depths below the surface of the reference block. Requisites for developing sound beam patterns in metal include: (1) means

for characterizing the ultrasonic search and ultrasonic flaw detection instrument with appropriate signal gating capability, (2) metal block containing side drilled holes, (3) mechanical means for traversing the search unit along the test block, (4) ultrasonic couplant for coupling the ultrasonic energy from the search unit into the metal block, (5) procedure for obtaining cross-axis profiles, and (6) analysis of the recorded responses.

A8.2 Search Unit Characterization and Ultrasonic Instrumentation—Characterization of the search unit to establish operational frequency and bandwidth prior to measurement of beam patterns is a basic requirement (see Annex A1 and Annex A2 of this guide). Once search unit characteristics are defined and agreed between users, a pulse-echo flaw detection instrument with appropriate signal gating capability (see A6.2.1) may be used to record the sound beam patterns. The

flaw detection instrument should be able to record signal responses from selected SDHs as the search unit is traversed along the block. Since the SDHs in the test block are at different depths, the recorded responses provide information that describes beam patterns in the metal block.

A8.3 Metal Test Block—The selection of the size of the metal block and the number and depth of the SDHs should be based on the design of the search unit. The series of SDHs, located at different depths below the surface, provide the targets from which the information describing the sound beam pattern, beam spread or focus and signal amplitude response may be obtained (12). A metal block that is 12-in. (300-mm) long, 4-in. (100-mm) high, and has a width of 1.25 to 1.5 in. (32 mm to 38 mm) is typical of test blocks for evaluating contact search units in the 2-to 15-MHz frequency range. The holes drilled through the thickness of the block must be straight and perpendicular to the side of the block so as to provide a constant reflecting surface to the sound beam. Hole diameters are typically 1/16 in. (1.6 mm). Distances from the top surface are spaced at intervals from 0.25 in. (6.35 mm) to 0.5 in. (12.7 mm) or greater depending on the size and frequency of the search unit.

NOTE A8.1—Inch (English) units are considered standard for this Annex. Appropriate metric values are included (in parenthesis) for convenience of the users.

NOTE A8.2—Block dimensions are not intended to be restricted to those listed above. Alternate dimensions and designs may be chosen by agreement between users.

A8.4 Mechanical Traversing Mechanism—Several types of mechanical traversing mechanisms, such as C-scan bridges, may be used to record the sound beam patterns from the SDHs.

Nonmechanical (manual) procedures are not recommended as they are subject to inaccuracies caused by factors such as couplant variations and inconsistent pressure between the search unit and the test block surface. Fig. A8.1 functionally describes one type of scanner for obtaining sound beam patterns. The figure shows the test block with SDHs. A spring-loaded holding fixture provides a constant pressure between the search unit and the block's surface. A spring-load pressure between 3 and 5 lbs. has been found to be sufficient to obtain reliable and repeatable results. The spatial position of the search unit is obtained from an encoder or micrometer dial/slide attached to the drive motor. From this information, the amplitude response from the SDHs can be correlated with the position of the search unit on the block. Care must be taken to ensure that the search unit is parallel to the surface of the block and is free from cant, skew or wobble as this can degrade the responses from the SDHs.

A8.5 Coupling of Ultrasonic Energy—A variety of coupling agents such as oil, glycerin, water or other ultrasonic couplant materials may be used. It is necessary to cover the top surface of the test block with the couplant, maintain it on the surface throughout the measurements and apply a constant pressure between the search unit and the surface of the block. If water is used, it is recommended that the block and the face of the search unit be immersed. Care must be taken to ensure SDHs are clear of any contamination (corrosion, couplant, etc.) that might affect the measurements.

A8.6 Cross-Axis Sound Beam Patterns—This Annex covers search units designed with single or dual, circular or rectangular piezoelectric elements. Patterns from these units must be measured in two orthogonal directions. The procedure is to

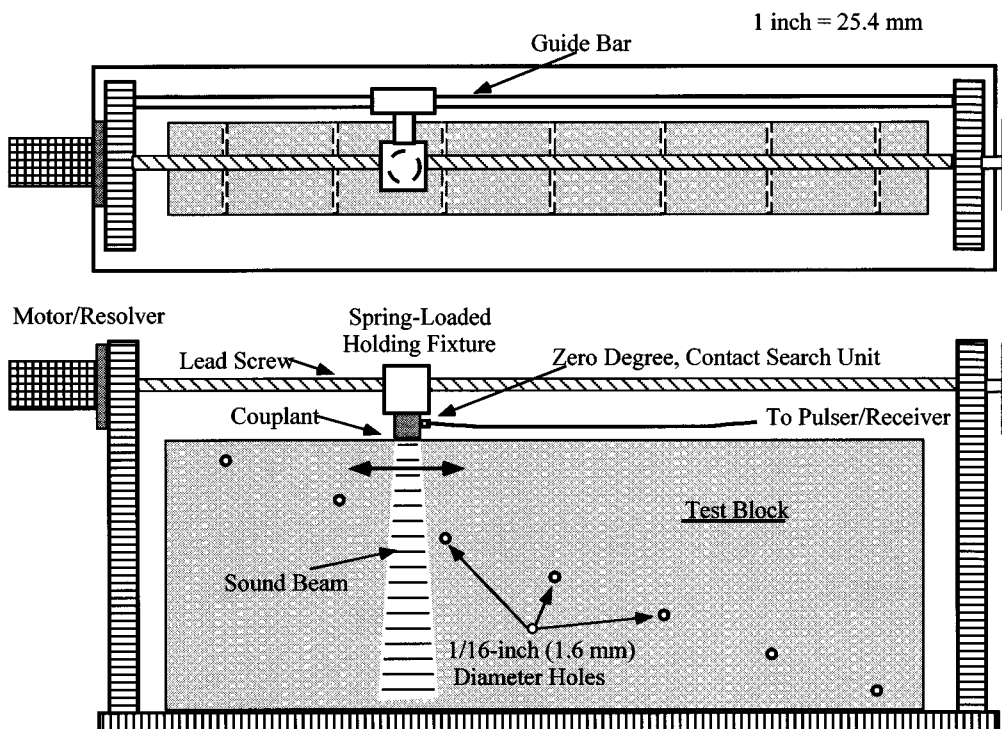

FIG. A8.1 Traversing Mechanism for Obtaining Straight Beam Sound Beam Patterns in Metal

record the pattern with the search unit placed in one orientation, then to rotate the search unit 90° and repeat the measurement. By comparing the records from the two measurements, parameters such as beam symmetry in two axes, beam divergence, dual search unit response and focus (if any) can be evaluated. Search units made with rectangular piezoelectric elements will have different beam patterns in the two orthogonal directions.

A8.7 Recorded Response—The ultrasonic beam pattern from a series of SDHs using a 3/8 in. diameter, 5 MHz search unit is shown in Fig. A8.2. An automated mechanical C-scan bridge was used to obtain these data. The search unit and block were immersed in water and the unit was spring-loaded to the block with approximately 3 lbs. of force. The block used for this example was made of aluminum and was 10-in. (250 mm) long, 5-in. (125 mm) high and 1-in. (25.4 mm) wide. The electronic gate was set wide enough to record signals from every depth of SDH without changing gate settings. The figure shows the ultrasonic beam pattern and amplitude from six SDHs spaced 1.0 in. (25.4 mm) apart and at depths ranging from 1.0 to 3.5 in. (25.4 to 89 mm). The pattern on the left is from the 1.0-in. (25.4 mm) deep hole while the one on the right is from the 3.5-in. (89 mm) deep hole. In the figure, the first four profiles are clearly separated but the last two do not have

the desired separation. This may indicate interference from adjacent holes, the side of the block, or from confounding multiple SDH signals in the gate. For accurate measurement of beam spread, the profiles from the SDHs should be clearly separated. These data can be used to estimate the beam spread at the -3, -6, -10 and -20 dB levels by measuring the beam width at two different depths and calculating the beam spread angle. Direct caliper measurements from the first and third patterns at -20dB on the record shows the width of the first beam pattern is approximately 0.3 in. and the width of the third pattern is approximately 0.45 in. or a difference of 0.15 in. To estimate the half-angle beam spread, the 0.15 value is divided in half. Since the distance between the holes is 1.0 in., the approximate beam spread can be calculated using the arctangent of $0.075 \div 1 = 4.28^\circ$. More precise measurements can be obtained using electronic time gating.

A8.7.1 The size of the block, depth of SDHs and separation between holes should be selected based on the size and frequency of the search unit being characterized to ensure that there is no interference between adjacent holes and reflections from the sides of the block. Calculations of the beam spread half-angles can verify the predicted beam spread and this information can be used to ensure that no interference is present.

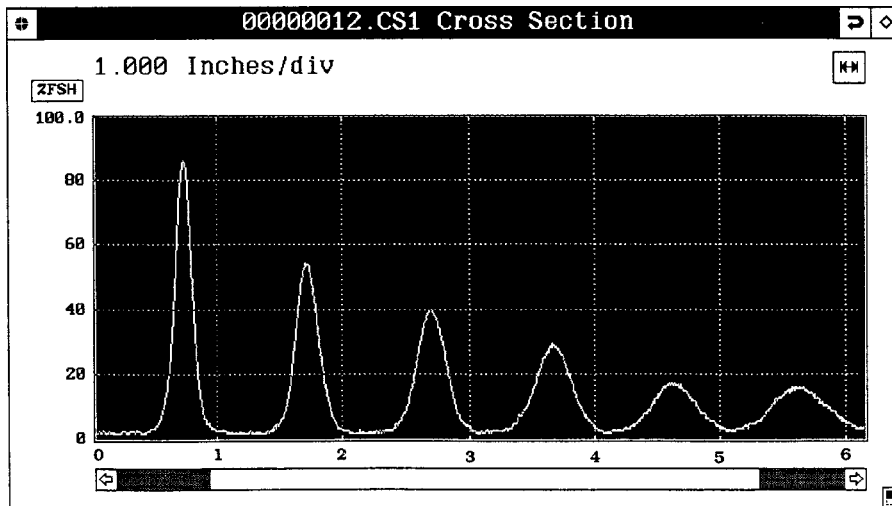

FIG. A8.2 Ultrasonic Response from SDHs in a Reference Block

REFERENCES

- (1) Busse, L. J., et al., "Characterization Methods for Ultrasonic Test Systems," U.S. Nuclear Regulatory Commission, NUREG/CR-2264/PNL-4215, July 1982.
- (2) Erickson, K. R., "Tone-Burst Testing of Pulse-Echo Transducers," *IEEE Sonics and Ultrasonics*, SU-26, No. 1, 1979.
- (3) Krautkramer, J., et al., *Ultrasonic Testing of Materials*, 2nd ed., Springer-Verlag, NY, 1977, p. 72.
- (4) Ophir, J., and Jaeger, D., "Spectral Shifts of Ultrasonic Propagation through Media with Nonlinear Dispersive Attenuation," *Ultrasonic Imaging* 4, 1982, pp. 282–289.
- (5) Kinsler, L. E., and Frey, A. R., *Fundamentals of Acoustics*, 2nd ed., John Wiley & Sons, Inc. 1962, p. 226.
- (6) Markham, J. J., Beyer, R. T., and Lindsay, R. B., "Absorption of Sound in Fluids," *Reviews of Modern Physics*, Vol 23, No. 4, 1951, pp. 353–411, (p. 396 op.cit.).
- (7) Sette, Daniele, "Dispersion and Absorption of Sound Waves in Liquids and Mixtures of Liquids," *Encyclopedia of Physics*, (Flügge, S., ed.), Vol XI/I, Acoustics I, Springer-Verlag (Berlin), 1961, pp. 275–360, (pp. 318–321 op.cit.).
- (8) Tschiegg, C. E., Greenspan, Martin, and Eitzen, D. G., "Ultrasonic Continuous-Wave Beam-Power Measurements; International Inter-comparison," *Journal of Research of the National Bureau of Standards*, Vol 88, No. 2, 1983, pp. 91–103, (p. 102 op.cit.).
- (9) Beck, K. H., "Ultrasonic Transducer Focusing for Inspection of Cylindrical Material," *Materials Evaluation*, Vol 49, No. 7, July 1991, pp. 875–882.
- (10) Beck, K. H., "Ultrasonic Area-Amplitude Linearity Limitations," *Materials Evaluation*, Vol 50, No. 8, August 1992, pp. 978–985.
- (11) Chaskelis, H. H., and Hart, S. D., "The Significance of Target Geometry on Far Field Beam Patterns," *Proc. 10th Symposium on NDE*, San Antonio, April 1975, ASNT and SRI.
- (12) ISO/DIS - 18375, *Nondestructive Testing* "Characterization of Search Unit and Sound Field," Rev 11, September 1995.

ASTM International takes no position respecting the validity of any patent rights asserted in connection with any item mentioned in this standard. Users of this standard are expressly advised that determination of the validity of any such patent rights, and the risk of infringement of such rights, are entirely their own responsibility.

This standard is subject to revision at any time by the responsible technical committee and must be reviewed every five years and if not revised, either reapproved or withdrawn. Your comments are invited either for revision of this standard or for additional standards and should be addressed to ASTM International Headquarters. Your comments will receive careful consideration at a meeting of the responsible technical committee, which you may attend. If you feel that your comments have not received a fair hearing you should make your views known to the ASTM Committee on Standards, at the address shown below.

This standard is copyrighted by ASTM International, 100 Barr Harbor Drive, PO Box C700, West Conshohocken, PA 19428-2959, United States. Individual reprints (single or multiple copies) of this standard may be obtained by contacting ASTM at the above address or at 610-832-9585 (phone), 610-832-9555 (fax), or service@astm.org (e-mail); or through the ASTM website (www.astm.org).