

This document is not an ASTM standard and is intended only to provide the user of an ASTM standard an indication of what changes have been made to the previous version. Because it may not be technically possible to adequately depict all changes accurately, ASTM recommends that users consult prior editions as appropriate. In all cases only the current version of the standard as published by ASTM is to be considered the official document.



Designation: E 1118 – 95



Standard Practice for Acoustic Emission Examination of Reinforced Thermosetting Resin Pipe (RTRP)¹

This standard is issued under the fixed designation E 1118; the number immediately following the designation indicates the year of original adoption or, in the case of revision, the year of last revision. A number in parentheses indicates the year of last reapproval. A superscript epsilon (ε) indicates an editorial change since the last revision or reapproval.

¹ This practice is under the jurisdiction of ASTM Committee E-7 E07 on Nondestructive Testing and is the direct responsibility of Subcommittee E07.04 on Acoustic Emission.

Current edition approved Jan. 15, 1995; Dec. 10, 2000. Published March 1995; Feb. 2001. Originally published as E 1118 – 86. Last previous edition E 1118 – 895.

1. Scope

1.1 This practice covers acoustic emission (AE) examination or monitoring of reinforced thermosetting resin pipe (RTRP) to determine structural integrity. It is applicable to lined or unlined pipe, fittings, joints, and piping systems.

1.2 This practice is applicable to pipe that is fabricated with fiberglass and carbon fiber reinforcements with reinforcing contents greater than 15 % by weight. The suitability of these procedures must be demonstrated before they are used for piping that is constructed with other reinforcing materials.

1.3 This practice is applicable to tests below pressures of 35 MPa absolute (5000 psia).

1.4 This practice is limited to pipe up to and including 0.6 m (24 in.) in diameter. Larger diameter pipe can be examined with AE, however, the procedure is outside the scope of this practice.

1.5 This practice applies to examinations of new or in-service RTRP.

1.6 The values stated in SI units are to be regarded as the standard. The values given in parentheses are for information only.

1.7 *This standard does not purport to address all of the safety concerns, if any, associated with its use. It is the responsibility of the user of this standard to establish appropriate safety and health practices and to determine the applicability of regulatory limitations prior to use.* For more specific safety precautionary information see 8.1.

2. Referenced Documents

2.1 ASTM Standards:

D 883 Terminology Relating to Plastics²

E 650 Guide for Mounting Piezoelectric Acoustic Emission Sensors³

E 750 Practice for ~~Measuring Operating Characteristics of~~ Characterizing Acoustic Emission Instrumentation³

E 976 Guide for Determining the Reproducibility of Acoustic Emission Sensor Response³

E 1316 Terminology for Nondestructive Examinations³

2.2 ASNT Standards:⁴

ANSI/ASNT CP-189 Personnel Qualification and Certification in Nondestructive Testing

ASNT SNT-TC-1A Personnel Qualification and Certification in Nondestructive Testing

2.3 Military Standards:⁵

MIL-STD-410 Nondestructive Testing Personnel Qualification and Certification

NAS-410 Certification and Qualification of Nondestructive Test Personnel

3. Terminology

3.1 Complete glossaries of terms related to plastics and acoustic emission will be found in Terminologies D 883 and E 1316.

3.2 Definitions of Terms Specific to This Standard:

3.2.1 *component and assembly proof testing*—a program of tests on RTRP components designed to assess product quality in a manufacturer's plant, at the installation site, or when taken out of service for retesting. An assembly is a shippable unit of factory-assembled components.

² Annual Book of ASTM Standards, Vol 08.01.

³ Annual Book of ASTM Standards, Vol 03.03.

⁴ Pentel 0.3 (2H) lead or its equivalent has been found satisfactory.

⁴ Available from American Society for this purpose: Nondestructive Testing, 1711 Arlingate Plaza, P.O. Box 28518, Columbus, OH 43228-0518.

⁵ Available from Standardization Documents Order Desk, Bldg. 4 Section D, 700 Robbins Ave., Philadelphia, PA 19111-5094, Attn: NPODS.

3.2.2 *count value* N_c —an evaluation criterion based on the total number of AE counts. (See A2.5.)

3.2.3 *diameter to thickness ratio* (d/t)—equal to $\frac{D_o + D_i}{2t}$

where (D_o) is the outside pipe diameter, (D_i) is the inside pipe diameter, and (t) is the wall thickness, as measured in a section of straight pipe.

3.2.4 *high-amplitude threshold*—a threshold for large amplitude events. (See A2.3.)

3.2.5 *in-service systems testing*—a program of periodic tests during the lifetime of an RTRP system designed to assess its structural integrity.

3.2.6 *low-amplitude threshold*—the threshold above which AE counts (N) are measured. (See A2.2.)

3.2.7 *manufacturers qualification testing*—a comprehensive program of tests to confirm product design, performance acceptability, and fabricator capability.

3.2.8 *operating pressure*—pressure at which the RTRP normally operates. It should not exceed design pressure.

3.2.9 *qualification test pressure*—a test pressure which is set by agreement between the user, manufacturer, or test agency, or combination thereof.

3.2.10 *rated pressure*—a nonstandard term used by RTRP pipe manufacturers as an indication of the maximum operating pressure.

3.2.11 *RTRP*—Reinforced Thermosetting Resin Pipe, a tubular product containing reinforcement embedded in or surrounded by cured thermosetting resin.

3.2.12 *RTRP system*—a pipe structure assembled from various components that are bonded, threaded, layed-up, etc., into a functional unit.

3.2.13 *signal value* M —a measure of the AE signal power (energy/unit time) which is used to indicate adhesive bond failure in RTRP cemented joints. (See A2.4.)

3.2.14 *summing amplifier* (*summer, mixer*)—an operational amplifier that produces an output signal equal to a weighted sum of the input signals.

3.2.15 *system proof testing*—a program of tests on an assembled RTRP system designed to assess its structural integrity prior to in-service use.

4. Summary of Practice

4.1 This practice consists of subjecting RTRP to increasing or cyclic pressure while monitoring with sensors that are sensitive to acoustic emission (transient stress waves) caused by growing flaws. Where appropriate, other types of loading may be superposed or may replace the pressure load, for example, thermal, bending, tensile, etc. The instrumentation and techniques for sensing and analyzing AE data are described.

4.2 This practice provides guidelines to determine the location and severity of structural flaws in RTRP.

4.3 This practice provides guidelines for AE examination of RTRP within the pressure range stated in 1.2. Maximum test pressure for RTRP will be determined upon agreement among user, manufacturer, or test agency, or combination thereof. The test pressure will normally be 1.1 multiplied by the maximum operating pressure.

5. Significance and Use

5.1 The AE examination method detects damage in RTRP. The damage mechanisms detected in RTRP are as follows: resin cracking, fiber debonding, fiber pullout, fiber breakage, delamination, and bond or thread failure in assembled joints. Flaws in unstressed areas and flaws which are structurally insignificant will not generate AE.

5.2 This practice is convenient for on-line use under operating conditions to determine structural integrity of in-service RTRP usually with minimal process disruption.

5.3 Flaws located with AE should be examined by other techniques; for example, visual, ultrasound, and dye penetrant, and may be repaired and retested as appropriate. Repair procedure recommendations are outside the scope of this practice.

6. Basis of Application

6.1 Personnel Qualification

6.1.1 If specified in the contractual agreement, personnel performing examinations to this standard shall be qualified in accordance with a nationally recognized NDT personnel qualification practice or standard such as ANSI/ASNT-CP-189, SNT-TC-1A, MIL-STD-410, NAS-410, or a similar document and certified by the employer or certifying agency, as applicable. The practice or standard used and its applicable revision shall be identified in the contractual agreement between the using parties.

6.2 Qualification of Nondestructive Agencies—If specified in the contractual agreement, NDT agencies shall be qualified personnel. Qualification and evaluated as described in E-543. The applicable edition of E-543 shall be based on a documented program that certifies personnel capable specified in the contractual agreement.

6.3 Timing of conducting acoustic emission examinations Examination—The timing of RTRP. The documented program examination shall be in accordance with paragraph 11 unless otherwise specified.

6.4 Extent of Examination—The extent of examination shall be in accordance with paragraph 9.4 unless otherwise specified.

6.5 Reporting Criteria/Acceptance Criteria—Reporting criteria for the following general topics:

6.1.1 ~~Basic technology examination results shall be in accordance with paragraph 12 unless otherwise specified. Since acceptance criteria are not specified in this standard, they shall be specified in the contractual agreement.~~

~~6.6 Reexamination of acoustic emission:~~

~~6.1.2 Failure mechanisms Repaired/Reworked Items—Reexamination of reinforced plastics:~~

~~6.1.3 Acoustic emission instrumentation:~~

~~6.1.4 Instrumentation check out:~~

~~6.1.5 Loading requirements:~~

~~6.1.6 Data collection repaired/reworked items is not addressed in this standard and interpretation:~~

~~6.1.7 Examination report, if required shall be specified in the contractual agreement.~~

7. Instrumentation

7.1 The AE instrumentation consists of sensors, signal processors, and recording equipment. Additional information on AE instrumentation can be found in Practice E 750.

7.2 Instrumentation shall be capable of recording AE counts and AE events above the low-amplitude threshold. It shall also record events above the high-amplitude threshold as well as signal value *M* within specific frequency ranges, and have sufficient channels to localize AE sources in real time. It may incorporate (as an option) peak amplitude detection. An AE event amplitude measurement is recommended for sensitivity verification (see Annex A2). Amplitude distributions are recommended for flaw characterization. It is preferred that the AE instrumentation acquire and record count, event, amplitude, and signal value *M* information on a per channel basis. The AE instrumentation is further described in Annex A1.

7.3 Capability for measuring parameters such as time and pressure shall be provided. The pressure-load shall be continuously monitored to an accuracy of $\pm 2\%$ of the maximum test value.

8. Test Preparations

8.1 *Safety Precautions*—All plant safety requirements unique to the test location shall be met.

8.1.1 Protective clothing and equipment that is normally required in the area in which the test is being conducted shall be worn.

8.1.2 A fire permit may be needed to use the electronic instrumentation.

8.1.3 Precautions shall be taken against the consequences of catastrophic failure when testing, for example, flying debris and impact of escaping liquid.

8.1.4 Pneumatic testing is extremely dangerous and shall be avoided if at all possible.

8.2 *RTRP Conditioning*:

8.2.1 If the pipe has not been previously loaded, no conditioning is required.

8.2.2 If the pipe has been previously loaded, one of two methods shall be used. For both methods, the maximum operating pressure-load in the pipe since the previous examination must be known. If more than one year has elapsed since the last examination, the maximum operating pressure-load during the past year can be used. (See 11.2.3.)

8.2.2.1 Option I requires that the test shall be run from 90 up to 110 % of the maximum operating pressure-load. In this case no conditioning is required. (See Fig. 7.) If it is not possible to achieve over 100 % of the maximum operating pressure-load, Option II may be used.

8.2.2.2 Option II requires that the operating pressure-load be reduced prior to testing in accordance with the schedule shown in Table 1. In this case, the maximum pressure-load need be only 100 % of the operating pressure (see Fig. 8).

8.3 *RTRP Pressurizing-Loading*—Arrangements should be made to pressurize the RTRP to the appropriate pressure-load. Liquid is the preferred pressurizing medium. Holding pressure-load levels is a key aspect of an acoustic emission examination. Accordingly, provision shall be made for holding the pressure-load at designated check points.

8.4 *RTRP Support*—The RTRP system shall be properly supported.

8.5 *Environmental*—The normal minimum acceptable RTRP wall temperature is 4°C (40°F).

8.6 *Noise Reduction*—Noise sources in the examination frequency and amplitude range, such as malfunctioning pumps or valves, movement of pipe on supports, or rain, must be minimized since they mask the AE signals emanating from the pipe.

8.7 *Power Supply*—A stable grounded power supply, meeting the specification of the instrumentation, is required at the test site.

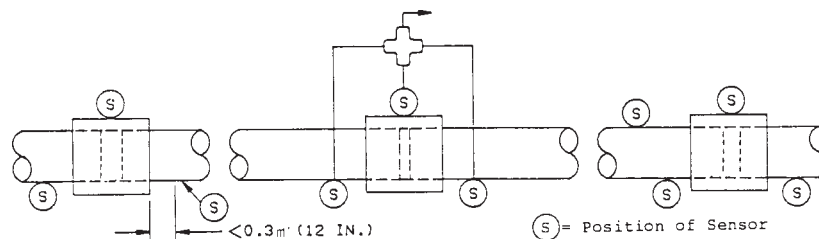

NOTE 1—A maximum of three sensors can be connected into one channel.

FIG. 1 Typical Sensor Positioning for Zone Location

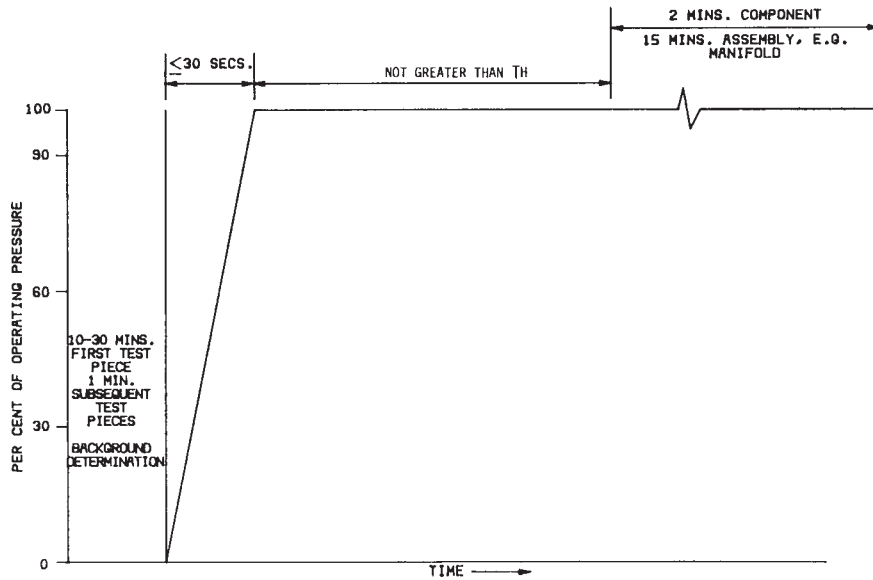

NOTE 1—Diameter to thickness ratio (d/t) ≥ 16 , $T_H = 2$ min. Diameter to thickness ratio (d/t) < 16 , $T_H = 4$ min.

FIG. 4 RTRP Component and Assembly Proof Test, Pressurizing Sequence

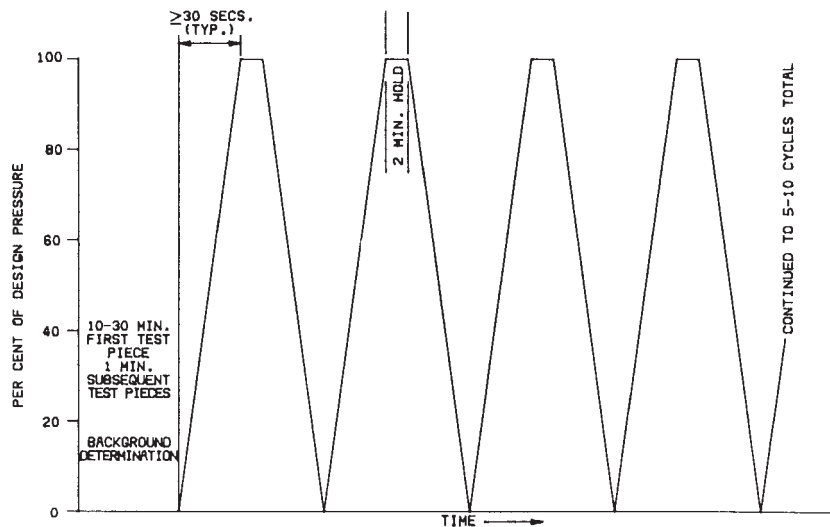

FIG. 5 RTRP Systems Proof Test, Pressurizing Sequence

Suitable adhesive systems are those whose bonding and acoustic coupling effectiveness have been demonstrated. The attachment method should provide support for the signal cable (and preamplifier) to prevent the cable(s) from stressing the sensor or causing loss of coupling.

9.2 *Surface Contact*—Reliable coupling between the sensor and pipe surface shall be ensured and the surface of the pipe in contact with the sensor shall be clean and free of particulate matter. Sensors should be mounted directly on the RTRP surface unless integral waveguides shown by test to be satisfactory are used. Preparation of the contact surface shall be compatible with both sensor and structure modification requirements. Possible causes of signal loss are coatings such as paint and encapsulants, inadequate sensor contact on curved surfaces, off-center sensor positioning and surface roughness at the contact area.

9.3 *Zone Location*—Several high-frequency sensors (100 to 250 kHz) are used for zone location of emission sources. Attenuation is greater at higher frequencies requiring closer spacing of sensors. Zones may be refined if events hit more than one sensor. (See Fig. 1 and Annex A3.)

9.4 *Locations and Spacings*—Sensor locations on the RTRP are determined by the need to detect structural flaws at critical sections, for example, joints, high-stress areas, geometric discontinuities, repaired regions, and visible defects. The number of sensors and their location is based on whether full coverage or random sampling of the system is desired. For full coverage of the RTRP, excluding joints, sensor spacings of 3 m (10 ft) are usually suitable.

9.4.1 *Attenuation Characterization*—Signal propagation losses shall be determined in accordance with the following procedure. This procedure provides a relative measure of the attenuation, but may not be representative of a genuine event. It should be noted

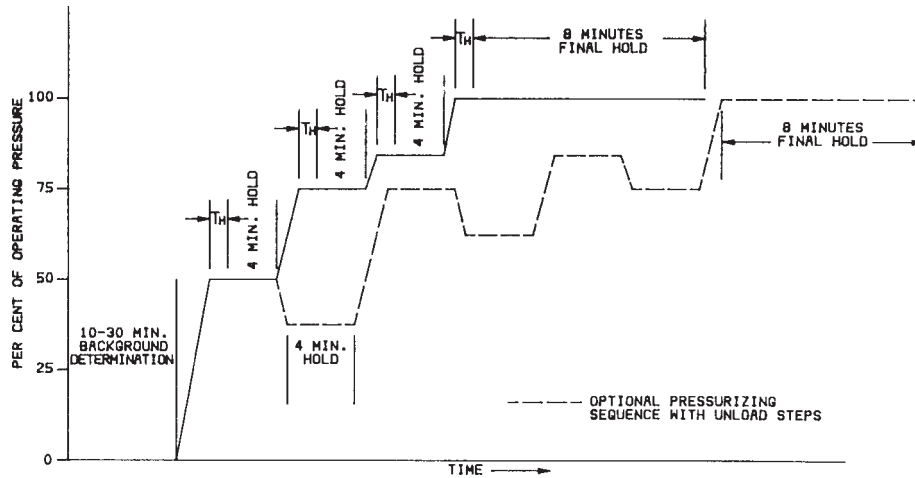

NOTE 1—Diameter to thickness ratio (d/t) ≥ 16, T_H = 2 min. Diameter to thickness ratio (d/t) < 16, T_H = 4 min.
FIG. 6 RTRP Systems Proof Test, Alternate Pressurizing Sequence

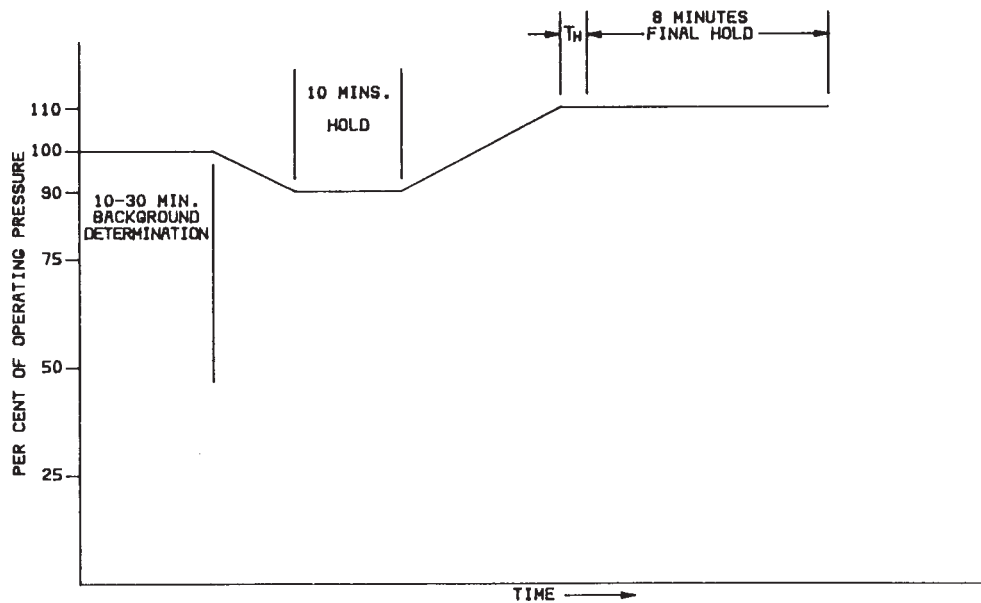

NOTE 1—Diameter to thickness ratio (d/t) ≥ 16, T_H = 2 min. Diameter to thickness ratio (d/t) < 16, T_H = 4 min.
FIG. 7 RTRP System In-Service Test, Option I, Pressurizing Sequence

TABLE 1 Option II Requirements for Reduced Operating Pressure-Load Immediately Prior to Testing

Percent of Operating Pressure or Load, or Both	Time at Reduced Pressure or Load, or Both
10 or less	12 h
20	18 h
30	30 h
40	2 days
50	4 days
60	7 days

that the peak amplitude from a mechanical pencil lead break may vary with surface hardness, resin condition, cure, and test fluid. For pressure tests, the attenuation characterization shall be carried out with the pipe full of the test fluid.

9.4.1.1 Select a representative region of the RTRP. Mount an AE sensor and locate points at distances of 150 mm (6 in.) and 300 mm (12 in.) from the center of the sensor along a line parallel to the axis of the pipe. Select two additional points on the surface of the pipe at 150 mm (6 in.) and 300 mm (12 in.) along a helix line inclined 45° to the direction of the original points. At each

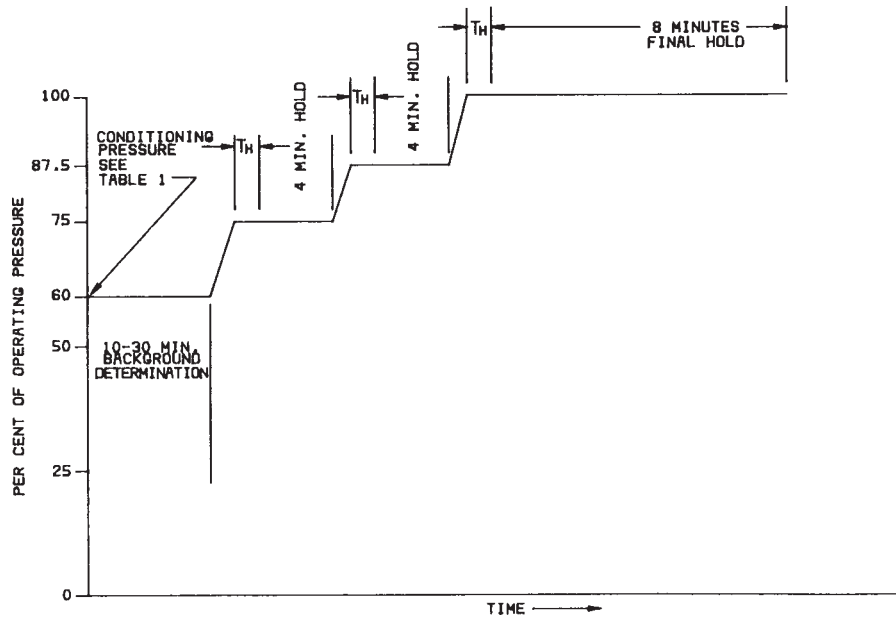

NOTE 1—Diameter to thickness ratio (d/t) ≥ 16 , $T_H = 2$ min. Diameter to thickness ratio (d/t) < 16 , $T_H = 4$ min.

FIG. 8 RTRP System In-Service Test, Option II, Pressurizing Sequence

of the four points, break 0.3-mm 2H leads⁶ and record peak amplitude. All lead breaks shall be done at an angle of approximately 30° to the test surface with a 2.5-mm (0.1-in.) lead extension (see Guide E 976). The data shall be retained as part of the original experimental record.

9.4.2 *Sensor Location*—Severe attenuation losses occur at unreinforced adhesive joint lines and across threaded joints. Accordingly, sensors should be located on either side of such interfaces. The sensor spacing on straight sections of pipe shall be not greater than $3 \times$ the distance at which the recorded amplitude from the attenuation characterization equals the low-amplitude threshold. The spacing distance shall be measured along the surface of the pipe.

9.4.3 Sensor zone location guidelines for the following RTRP configurations are given in Annex A3. Other configurations require an agreement among the user, manufacturer, or test agency, or combination thereof.

9.4.3.1 **Case I: Coupled**—Cemented or threaded joint pipe system. (The sensor on the coupling is normally required because the adhesive is highly attenuative.)

9.4.3.2 **Case II: Bell and Spigot**—Cemented or threaded joint pipe system.

9.4.3.3 **Case III: Hand Lay-up**—Field fabricated secondary bond mat joint pipe system.

9.4.3.4 **Case IV: Flanged Joint Pipe System.**

10. Instrumentation System Performance Check

10.1 *Sensor Coupling and Circuit Continuity Verification* —Verification shall be performed following sensor mounting and system hookup. The peak amplitude response of each sensor-preamplifier combination to a repeatable simulated acoustic emission source (see Annex A2) should be taken prior to the examination. The peak amplitude of the simulated event generated at 150 mm (6 in.) from each sensor should not vary more than 6 dB from the average of all the sensors. Any sensor-preamplifier combination failing this check should be investigated and replaced or repaired as necessary.

10.2 *Background Noise Check*—A background noise check is required to identify and determine level of spurious signals. This is done following completion of the verification described in 10.1 and prior to pressurizing the RTRP. A recommended time period is 10 to 30 min. A low level of background noise is important for conducting an examination and is particularly important for zone location. Continuous background noise at a level above the low amplitude threshold is unacceptable and must be reduced before conducting the examination.

11. Testing Procedure

11.1 *General Guidelines*—The RTRP is subjected to programmed increasing pressure-load levels to a predetermined maximum while being monitored by sensors that detect acoustic emission (stress waves) caused by growing structural flaws.

11.1.1 Load will normally be applied by internal pressurization of the pipe and this is the basis for the examination procedure outlined in this and following sections. Service conditions always include other kinds of significant loads. Such loads shall be included or simulated in the test and, where possible, should be applied in increments similar to the pressure.

⁶ Pentel 0.3 (2H) lead or its equivalent has been found satisfactory for this purpose.

11.1.2 With the exception of proof testing, pressurization rates of assembled pipe systems shall be controlled so as not to exceed a rate of 5 % (of operating pressure) per minute. Pressurizing rates for component and system proof testing (see 11.2) shall not exceed 100 % test pressure in 30 s. The desired pressure shall be attained with a liquid (see 8.1.3 and 8.1.4). A suitable calibrated gage shall be used to monitor pressure.

11.1.3 Background noise must be minimized and identified (see also 8.6 and 10.2). Excessive background noise is cause for suspension of pressurization. In the analysis of examination results, background noise that can be identified shall be separated out and properly discounted. Sources of background noise include the following: pumps, motors, meters and other mechanical devices, electromagnetic interference, movement on supports, and environmental factors such as rain, wind, etc.

11.2 *Pressurizing*—Four recommended pressurizing sequences are provided as follows:

1. Manufacturers Qualification Test
2. Component and Assembly (for example, Manifold) Proof Test
3. Systems Proof Test
4. System In-Service Test, Option I or Option II

The initial hold period in all cases is used to determine the background noise baseline. The data provides an estimate of the total background noise contribution during an examination. Intermittent and final load holds vary according to the type of testing done; see the appropriate pressurizing sequence. The test shall be monitored continuously during the final hold periods.

11.2.1 *Manufacturers Qualification Testing*—The recommended pressurizing sequence is shown in Fig. 2. The test algorithm flow chart is shown in Fig. 3. The qualification test pressure shall be set by agreement between user, manufacturer, or test agency, or combination thereof.

11.2.2 *Proof Testing*:

11.2.2.1 *Component and Assembly Proof Test*— The recommended pressurizing sequence for RTRP component and assembly proof tests is shown in Fig. 3. For component proof tests, total hold periods may be reduced provided that no emissions are recorded for a 2-min period.

11.2.2.2 *Systems Proof Test*—The recommended pressurizing sequences are shown in Figs. 5 and 6.

11.2.3 *In-Service Testing*:

11.2.3.1 *System In-Service Test, Option I (Preferred)*—The recommended pressurizing sequence is shown in Fig. 7.

11.2.3.2 *System In-Service Test, Option II*— The recommended pressurizing sequence is shown in Fig. 8. It is to be used only in those cases in which overpressurization is not allowed.

11.2.4 *AE Test Algorithm-Flow Charts*— Charts similar to Fig. 3 can be developed for the other pressurization/load sequences.

11.3 *Felicity Ratio Determination*—The Felicity Ratio is determined from unload/reload cycles, for manufacturer qualification and proof testing. Following the unload, and during the reload, the Felicity ratio is obtained directly from the ratio of stress at the emission source at onset of significant emission to the previous maximum stress at the same point.

11.3.1 The Felicity ratio for in-service tests is obtained directly from the ratio of stress at the emission source at onset of significant emission to the previous maximum operating stress at the same point.

11.4 *Data Recording*:

11.4.1 Prior to an examination the signal propagation loss (attenuation) data, that is, amplitude as a function of distance from the signal source, shall be recorded in accordance with the procedure detailed in 9.4.1.

11.4.2 During an examination the sum of counts above the low-amplitude threshold from all channels shall be monitored and recorded. The location of each active zone shall be determined and recorded (see Annex A2). The signal value M shall be monitored and its maximum recorded (see Annex A2). The number of events that exceed the high-amplitude threshold shall be recorded. Channels that are active during load holds should be noted.

12. Interpretation of Results

12.1 *Test Termination*—Departure from a linear count-load relationship should signal caution. If the AE count rate increases rapidly with stress, the RTRP shall be unloaded and that examination terminated. A rapidly (exponentially) increasing count rate indicates uncontrolled, continuing damage and is indicative of impending failure.

12.2 *Significance of Data*:

12.2.1 Evaluation based on emissions during load hold is particularly significant. Continuing emissions indicate continuing damage. Pressurizing and other background noise will generally be at a minimum during a load hold. Emissions continuing during hold periods is a condition on which accept/reject criteria may be based.

12.2.2 The signal value M is a sensitive measure of super-imposed subthreshold events which is particularly important for indicating adhesive bond failure in pipe joints. Signal values vary with instrument manufacturer. (See Annex A2.) Signal values which exceed a specified value of M is a condition on which accept/reject criteria may be based.

12.2.3 RTRP, particularly on first loading, tends to be noisy and, therefore, will generally require different interpretation from subsequent loadings.

12.2.4 Evaluation based on Felicity ratio is important for in-service RTRP. The Felicity ratio provides a measure of the severity for previously induced damage. The onset of *significant* emission for determining measurement of the Felicity ratio is a matter of experience. The following are offered as guidelines to determine if emission is significant:

12.2.4.1 More than 5 bursts of emission during a 10 % increase in load.

12.2.4.2 More than $N_c/25$ counts during a 10 % increase in load, where N_c is the count value defined in A2.5.

12.2.4.3 Emission continues at a load hold. For purposes of this guideline, a short (1 min or less) nonprogrammed load hold can be inserted in the procedure.

12.2.4.4 Felicity ratio is a condition on which accept/reject criteria may be based.

12.2.5 Evaluation based on high-amplitude events is important for new RTRP. These events are often associated with fiber breakage and are indicative of major structural damage. This condition is less likely to govern for in-service and previously loaded RTRP where emissions during a load hold and Felicity ratio generally are more important. High-amplitude events (above the high-amplitude threshold) is a condition on which accept/reject criteria may be based.

13. Report

13.1 The report shall include the following:

13.1.1 Complete identification of the RTRP, including material type, source, method of fabrication, manufacturer's name and code number, date and pressure-load of previous tests, and previous history.

13.1.2 Dimensioned sketch or manufacturer's drawing of the RTRP system showing sensor locations, including the results of sensor coupling and circuit continuity verification.

13.1.3 Test liquid employed.

13.1.4 Test liquid temperature.

13.1.5 *Test Sequence*—Pressurizing-loading rate, hold times, and hold levels.

13.1.6 Comparison of examination data with specified accept/reject criteria and an assessment of the location and severity of structural flaws based on the data.

13.1.7 Show on sketch (see 13.1.2) or manufacturer's drawing the location of any zones with AE activity exceeding acceptance criteria.

13.1.8 Any unusual effects or observations during or prior to the examination.

13.1.9 Dates of examination.

13.1.10 Name(s) of examiner(s).

13.1.11 *Instrumentation Description*—Complete description of AE instrumentation including manufacturer's name, model number, sensor type, system gain, serial numbers of equivalent, software title, and version number.

13.1.12 Permanent record of AE data, for example, signal value M versus time for zones of interest, total counts above the low-amplitude threshold versus time, number of events above the high-amplitude threshold, emissions during load holds, signal propagation loss (see 9.4.1).

14. Keywords

14.1 adhesive joints; Felicity effect; Felicity ratio; FRP pipe; load hold; RTRP; zone location

ANNEXES

(Mandatory Information)

A1. INSTRUMENTATION PERFORMANCE REQUIREMENTS

A1.1 AE Sensors

A1.1.1 *General*—AE sensors shall operate without electronic or other spurious noise above the low-amplitude threshold over a temperature range from 4 to 93°C (40 to 200°F), and shall not exhibit sensitivity changes greater than 3 dB over this range. Sensors shall be shielded against radio frequency and electromagnetic noise interference through proper shielding practice or differential (anticoincident) element design, or both. Sensors shall have omnidirectional response in the plane of contact, with variations not exceeding 4 dB from the peak response.

A1.1.2 *Sensors*—Sensors shall have a resonant response between 100 and 200 kHz. Minimum sensitivity shall be – 80 dB referred to 1 V/microbar, determined by face-to-face ultrasonic test.

NOTE A1.1—This method measures approximate sensitivity of the sensor. AE sensors used in the same examination should not vary in peak sensitivity more than 3 dB from the average. Additional information on AE sensor response can be found in Guide E 976.

A1.1.3 *Signal Cable*—The signal cable from sensor to preamp shall not exceed 2 m (6 ft) in length and shall be shielded against electromagnetic interference. This requirement is omitted where the preamplifier is mounted in the sensor housing, or a line-driving (matched impedance) sensor is used.

A1.1.4 *Couplant*—Commercially available couplants for ultrasonic flaw detection may be used. Frangible wax or quick-setting adhesives may be used, provided couplant sensitivity is no lower than with fluid couplants. Couplant selection should be made to

minimize changes in coupling sensitivity during an examination. Consideration should be given to testing time and the surface temperature of the pipe.

A1.1.5 Pre-amplifier—The preamplifier should be mounted in the vicinity of the sensor, or may be in the sensor housing. If the preamp is of differential design, a minimum of 40 dB of common-mode noise rejection shall be provided. The preamplifier band pass shall be consistent with the frequency range of the sensor and shall not attenuate the resonant frequency of the sensor.

A1.1.6 Filters—Filters shall be of the band pass or high-pass type, and shall provide a minimum of 24 dB per octave signal attenuation. Filters may be located in preamplifier or post-preamplifier circuits, or may be integrated into the component design of the sensor, preamp, or processor to limit frequency response. Filters or integral design characteristics, or both, shall ensure that the principal processing frequency from sensors is not less than 100 kHz.

A1.1.7 Power-Signal Cable—The cable providing power to the preamplifier and conducting the amplified signal to the main processor shall be shielded against electromagnetic noise. Signal loss shall be less than 1 dB/300 m (1000 ft) of cable length at 200 kHz. The recommended maximum cable length is 300 m (1000 ft) to avoid excessive signal attenuation. Digital or radio transmission of signals is allowed consistent with standard practice in transmitting those signal forms.

A1.1.8 Main Amplifier—The main amplifier, if used, shall have signal response with variations not exceeding 3 dB over the frequency range from 20 to 300 kHz, and temperature range from 4 to 50°C (40 to 122°F). The main amplifier shall have adjustable gain, or an adjustable threshold for event detection and counting.

A1.1.9 Main Processor:

A1.1.9.1 General—The main processor(s) shall have a minimum of one active data processing circuit. If independent channels are used, the processor shall be capable of processing events and counts on each channel. No more than three sensors may be connected in common to a single preamplifier, and no more than two preamplifiers may be connected in common to a single channel.

(1) If a summing amplifier is used, it shall provide a minimum processing capability for event detection on eight channels (preamp inputs). Provisions to sum or exclude any of the channel inputs will be within real-time operator control.

(2) Total counts shall be processed from all channels. Signal values shall also be processed from all channels.

A1.1.9.2 Peak Amplitude Detection—If peak-amplitude detection is practiced, comparative calibration must be established in accordance with the requirements of Annex A2. Usable dynamic range shall be a minimum of 60 dB with 2-dB resolution. Not more than 2-dB variation in peak detection accuracy shall be allowed over the stated temperature range. Amplitude values may be stated in volts or decibels, but must be referenced to a fixed gain output of the system (sensor or preamp).

A1.1.9.3 Signal Outputs and Recording—The processor as a minimum shall provide outputs for permanent recording of total counts above low-amplitude threshold, total events above the high-amplitude threshold, and signal value *M* for all channels, and events by channel (zone location). A sample schematic is shown in Fig. A1.1.

A2. INSTRUMENT CALIBRATION

A2.1 General—The performance and threshold definitions vary for different types of acoustic emission equipment. Processing of parameters such as amplitude and energy varies from manufacturer to manufacturer, and from model to model by the same manufacturer. This annex defines procedures for determining the low-amplitude threshold, high-amplitude threshold, count value *N_c*, and signal value *M*.

A2.1.1 The procedures defined in this annex are intended for baseline instrument calibration at 15 to 27°C (60 to 80°F). It is recommended that instrumentation users develop calibration techniques along the lines outlined in this annex. For field use, small portable fiberglass reinforced plastic (FRP), or similar, samples can be carried with the equipment and used for periodic checking of sensor, preamplifier, and channel sensitivity.

A2.2 Low-Amplitude Threshold—The low-amplitude threshold shall be determined using 120 cm by 180 cm by 1.3-cm (4 ft by 6 ft by ½-in.) 99 % pure lead sheet. The sheet shall be suspended clear of the floor. The low-amplitude threshold is defined as

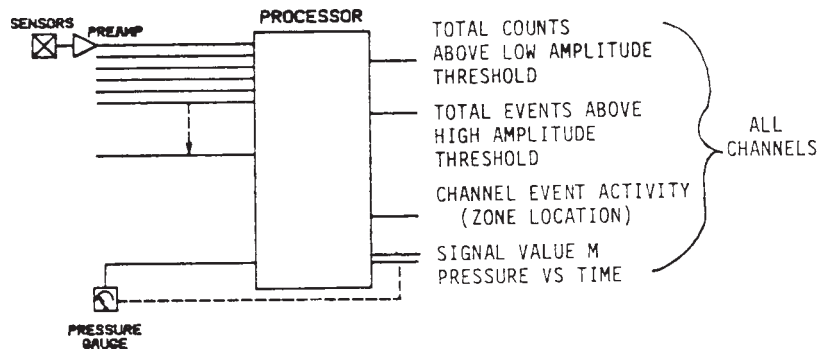

FIG. A1.1 Sample Schematic of AE Instrumentation

the average measured amplitude of ten events generated by a 0.3-mm mechanical pencil (2H) lead break at a distance of 130 cm (4 ft-3 in.) from the sensor. All lead breaks shall be done at an angle of approximately 30° to the test surface with a 2.5-mm (0.1-in.) lead extension. The sensor shall be mounted 15 cm (6 in.) from the 120-cm (4-ft) side and mid-distance between 180-cm (6-ft) sides.

A2.3 *High-Amplitude Threshold*—For large amplitude events, the high-amplitude threshold shall be determined using a 300 cm by 5 cm by 2-cm (10 ft by 2 in. by ¾-in.) clean, mild steel bar. The bar shall be supported at each end on elastomeric, or similar, isolating pads. The high-amplitude threshold is defined as the average measured amplitude of ten events generated by a 0.3-mm mechanical pencil (2H) lead break at a distance of 210 cm (7 ft) from the sensor. The sensor shall be mounted 30 cm (12 in.) from the end of the bar on the 5-cm (2-in.) wide surface.

A2.4 *Signal Value M, Electronic Calibration*—Signal value *M* is an indicator of adhesive bond failure. It is a continuous measurement resulting from ongoing averaging of the input signal over a 5 to 10-ms period. The reference signal value *M_o* is the instrument output which is obtained from an electronically generated input of a 10-ms duration, 150-kHz sine wave with a peak voltage five times the low-amplitude threshold. Input of a 150-kHz sine burst of 100-µs duration at peak voltage 50 times the low-amplitude threshold should result in a signal value no greater than 0.1 *M_o*. For instruments which include a filter in the main processor, the frequency of the sine burst may be at the center frequency of the filter, provided it is between 100 and 200 kHz. Different techniques are used by different instrument manufacturers for measuring the signal value. The units of the signal value will vary depending upon the techniques and instrument that is used.

A2.5 *Count Value N_c* —The count value *N_c* shall be determined either before or after the examination using a 0.3-mm mechanical pencil (2H) lead broken on the surface of the pipe. All lead breaks shall be done at an angle of approximately 30° to the test surface with a 2.5-mm (0.1-in.) lead extension. Calibration points shall be chosen at the midpoint of the pipe and on couplings and fittings, so as to be representative of different constructions and thicknesses, and should be performed with the pipe full of test fluid.

A2.5.1 A sensor shall be mounted at each calibration point and two calibrations shall be carried out at each location. One calibration shall be in the principal direction of the surface fibers (if applicable), and the second calibration shall be carried out along a line at 45° to the direction of the first calibration. Lead breaks shall be at a distance from the calibration point so as to provide an amplitude decibel value midway between the low-amplitude threshold (see A2.2) and high-amplitude threshold (see A2.3).

A2.5.2 The count value *N_c* at each calibration point is defined as five times the total counts recorded from 13 lead breaks at each of the two lead break locations.

A2.5.3 When applying the count evaluation, the count value, which is representative of the region (construction and thickness) where activity is observed, should be used.

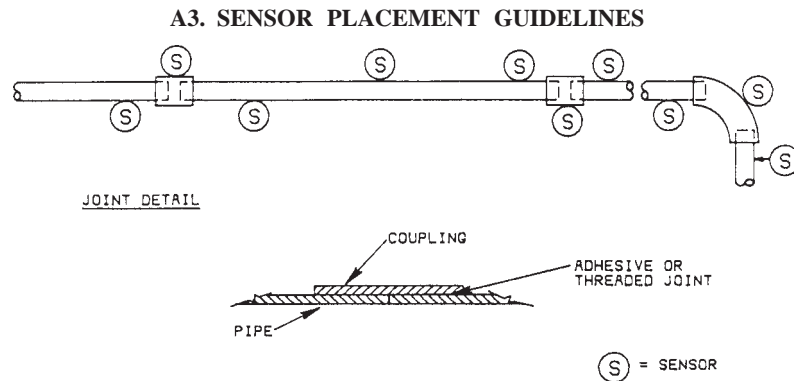

A3.1 *Case I Coupled*—Cemented or threaded joint system.

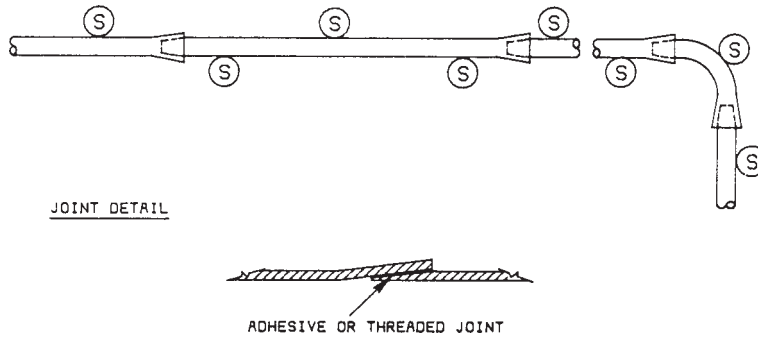

A3.2 Case II Bell and Spigot —Cemented or threaded joint system.

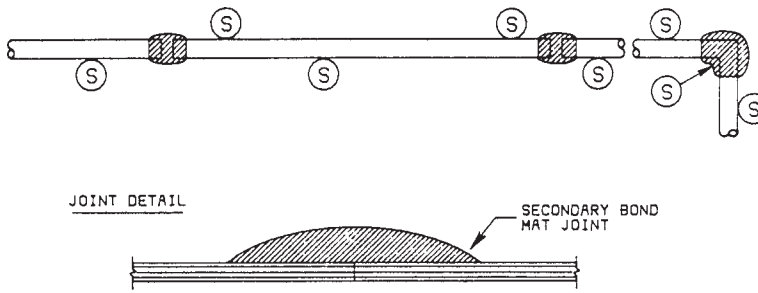

A3.3 Case III Hand Up —Field fabricated secondary bond mat joint pipe system.

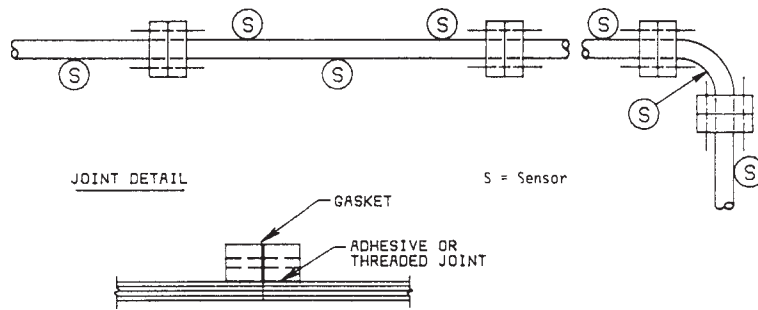

A3.4 Case IV—Flanged joint pipe system.

APPENDIX

(Nonmandatory Information)

X1. RATIONALE

X1.1 This practice was rewritten from the “Recommended Practice for Acoustic Emission Testing of Reinforced Thermosetting Resin Pipe,” which was developed by the Committee on Acoustic Emission from Reinforced Plastics (CARP) and published by the Reinforced Plastics/Composites Institute of the Society of the Plastics Industry (SPI).

X1.2 The CARP Recommended Practice has been used successfully on numerous applications.

ASTM International takes no position respecting the validity of any patent rights asserted in connection with any item mentioned in this standard. Users of this standard are expressly advised that determination of the validity of any such patent rights, and the risk of infringement of such rights, are entirely their own responsibility.

This standard is subject to revision at any time by the responsible technical committee and must be reviewed every five years and if not revised, either reapproved or withdrawn. Your comments are invited either for revision of this standard or for additional standards and should be addressed to ASTM International Headquarters. Your comments will receive careful consideration at a meeting of the responsible technical committee, which you may attend. If you feel that your comments have not received a fair hearing you should make your views known to the ASTM Committee on Standards, at the address shown below.

This standard is copyrighted by ASTM International, 100 Barr Harbor Drive, PO Box C700, West Conshohocken, PA 19428-2959, United States. Individual reprints (single or multiple copies) of this standard may be obtained by contacting ASTM at the above address or at 610-832-9585 (phone), 610-832-9555 (fax), or service@astm.org (e-mail); or through the ASTM website (www.astm.org).