



Designation: E 1158 – 98

Standard Guide for Material Selection and Fabrication of Reference Blocks for the Pulsed Longitudinal Wave Ultrasonic Examination of Metal and Metal Alloy Production Material¹

This standard is issued under the fixed designation E 1158; the number immediately following the designation indicates the year of original adoption or, in the case of revision, the year of last revision. A number in parentheses indicates the year of last reapproval. A superscript epsilon (ϵ) indicates an editorial change since the last revision or reapproval.

1. Scope

1.1 This guide covers general procedures for the material selection and fabrication of reference blocks made of metal or metal alloys and intended to be used for the pulsed longitudinal wave ultrasonic examination of the same or similar production materials.

1.2 This guide covers the fabrication of reference blocks for use with either the immersion or the direct-contact method of ultrasonic examination.

1.3 Reference blocks fabricated in accordance with this guide can be used to determine proper ultrasonic examination system operation. Area-amplitude and distance-amplitude curves can also be determined with these reference blocks.

1.4 This guide does not specify calibration reflector sizes or product rejection limits. It does describe typical industry fabrication practices and commonly applied tolerances where they lend clarity to the guide. In all cases of conflict between this guide and customer specifications, the customer specification shall prevail.

1.5 *This standard does not purport to address the safety concerns, if any, associated with its use. It is the responsibility of the user of this standard to establish appropriate safety and health practices and to determine the applicability of regulatory limitations prior to use.*

2. Referenced Documents

2.1 ASTM Standards:

E 127 Practice for Fabricating and Checking Aluminum Alloy Ultrasonic Standard Reference Blocks^{2,3}

¹ This guide is under the jurisdiction of ASTM Committee E-7 on Nondestructive Testing and is the direct responsibility of Subcommittee E07.06 on Ultrasonic Method.

Current edition approved Dec. 10, 1998. Published February 1999. Originally published as E 1158-90. Last previous edition E 1158-90(1994)¹.

² *Annual Book of ASTM Standards*, Vol 03.03.

³ The reference blocks in Practice E 127 are used to check the performance of ultrasonic testing equipment and for standardization and control of ultrasonic tests of aluminum alloy products. The ultrasonic response of the blocks in Practice E 127 is evaluated against a standard target. The blocks described in this standard are used for the examination of production material and may be used to establish accept-reject criteria.

E 428 Practice for Fabrication and Control of Steel Reference Blocks Used in Ultrasonic Inspection²
E 1316 Terminology for Nondestructive Examinations²

3. Terminology

3.1 *Definitions*—For definitions of terms used in this guide, see Terminology E 1316.

4. Summary of Guide

4.1 This guide describes a method of selecting suitable reference block material from current or previous production and the subsequent fabrication and checking of the resulting ultrasonic reference blocks.

5. Significance and Use

5.1 This guide is intended to illustrate the fabrication of ultrasonic reference blocks that are representative of the production material to be examined. Care in material selection and fabrication can result in the manufacture of reference blocks that are ultrasonically similar to the production material thus eliminating the reference block as an examination variable.

6. Material Selection

6.1 It is good practice to use a sample removed from the production lot of material as the reference block material. When this is not possible the following guidelines should be followed.

6.2 The reference block material should be of the same general shape and dimensions, surface finish, chemical composition, and microstructure as the production material to be examined.

6.3 To ensure that the material chosen is suitable for use as reference block material and is free of potentially interfering reflectors, ultrasonically examine the reference block material at the anticipated examining frequency and at a sensitivity that produces an acoustic noise level of 20 % screen height. The entire block should be scanned from the surface which will be used for calibration. Any discrete indication that exceeds 40 %

screen height should be cause to remove the material from consideration as an ultrasonic reference block.

6.4 Reference block material that meets the guidelines of 6.3 should then be examined at a sensitivity that produces multiple reflections from the back surface (between 3 and 5 reflections in most metals and metal alloys). The production material should be examined at the same sensitivity level to determine that the same number of back reflections are obtained. This procedure may have to be repeated several times and an average number of back reflections determined in the case of some materials (see Note 1).

NOTE 1—In some highly attenuative materials more than one or two back reflections may not be attainable. In these cases, selection of the reference block material may be based on similar acoustic noise levels from both the production material and that chosen for a reference block.

7. Reference Block Configuration

7.1 There are many different types of reference blocks used in industry depending upon the size and shape of the material to be examined. Some of the more common types are described in 7.2 through 7.7, and shown in Figs. 1-7.

7.2 Fig. 1 shows the typical reference standards used for ultrasonic examination when the product to be examined consists of large round bar stock, between 1 and 10 in. in diameter. With such products it is often necessary to correct for the loss of signal with increasing examination distance (distance-amplitude-correction, or DAC). Therefore, a stepped block, as shown in Fig. 1 is commonly used. This type of block is typically referred to as a distance-amplitude-block. It contains a number of holes of the same size at various distances from the scan surface. A typical flat-bottom hole size found in many such blocks is $\frac{5}{64}$ in. or larger depending upon the ultrasonic attenuation, or the internal structure of the product, or both. For even larger diameter bars the distance amplitude correction reference standard may contain even larger flat bottom holes, possibly $\frac{1}{4}$ in. or greater.

7.3 To determine the linearity of the examination and to establish the quality level of the large-diameter product, (7.2), an area-amplitude reference block as shown in Fig. 2 is common. An area-amplitude-block contains holes of different cross-sectional areas placed at the same distance from the scan surface. Typical hole sizes range from between $\frac{3}{64}$ and $\frac{8}{64}$ in. with even larger flat-bottom holes used in reference blocks intended for use for the largest bars.

7.4 For small round bar stock, typically 1 in. and under, a distance-amplitude block is normally not required. The typical

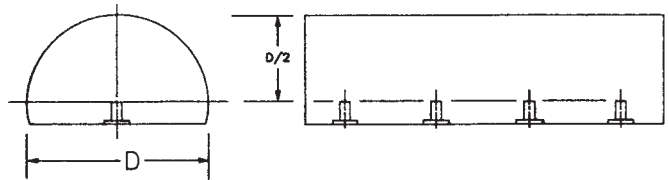

NOTE 1—Holes are of different diameters.
FIG. 2 Typical Area-Amplitude Reference Block for use in Ultrasonic Examination of Round Bars as in Fig. 1

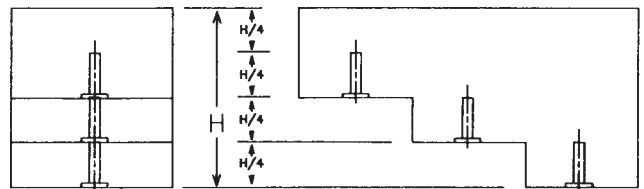

NOTE 1—All holes are the same diameter.
FIG. 3 Typical Distance-Amplitude Reference Block for the Ultrasonic Examination of Large Square or Rectangular Bars Greater than 1 in.

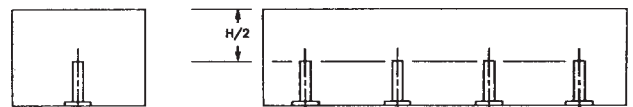

NOTE 1—Holes are of different diameters.
FIG. 4 Typical Area-Amplitude Reference Block for the Ultrasonic Examination of Square or Rectangular Bars

area-amplitude block for this product is the same as for the larger diameter material as shown in Fig. 2, but on a smaller scale. The hole sizes typically range from between $\frac{2}{64}$ and $\frac{5}{64}$ in. for many metal and metal alloy products.

7.5 When the product to be examined consists of large square or rectangular bar stock, the distance-amplitude reference block is often of the type shown in Fig. 3. The typical area-amplitude reference block is shown in Fig. 4. The reference block hole sizes are typically the same as those used for similar thickness round bars.

7.6 The smaller sizes of square or rectangular bar stock, 1 in. and under in the direction of examination, often do not require the use of a distance-amplitude reference block. The area-amplitude block may be similar to that shown in Fig. 4. The reference block hole sizes are usually similar to those used for round bars of the same thickness.

7.7 The reference blocks used for the ultrasonic examination of products with more complex geometries are normally fabricated from production samples so that the effects of geometry variations are minimized.

8. Fabrication Procedure

8.1 Specific fabricating procedures are dependent upon the configuration of the reference block, the block composition, the examination criticality, and even the skill of the machinists. Some general guidelines are given in 8.2 through 8.3.2.

8.2 *Flat-Bottom Holes*—Flat-bottom holes (FBH'S) should be drilled such that the hole bottom is perpendicular to the

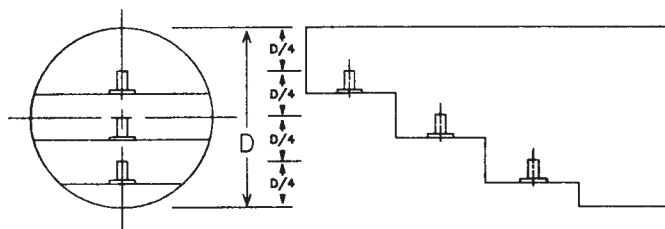

NOTE 1—All holes are the same diameter.
FIG. 1 Typical Distance-Amplitude Reference Block Configuration for the Ultrasonic Examination of Large Metal and Metal Alloy Bars of from 1 to 10 in. Diameter and Larger

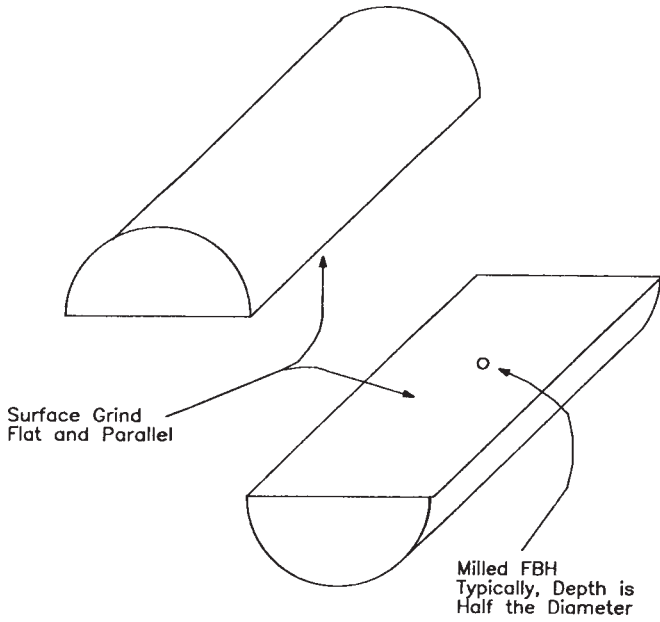

NOTE 1—The finish and fitup of the mating surfaces strongly influence the success of the bond.

FIG. 5 Typical Example of a Diffusion Bonded Reference Block for Small Diameter Round Bars

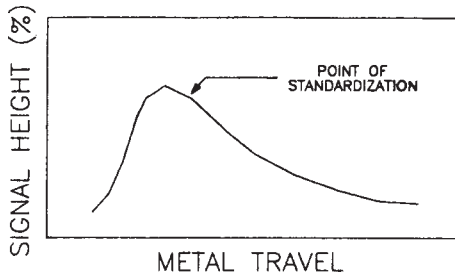

NOTE 1—The shape of the curve may differ as discussed in 10.1.

FIG. 6 Typical Distance-Amplitude Ultrasonic Response Curve

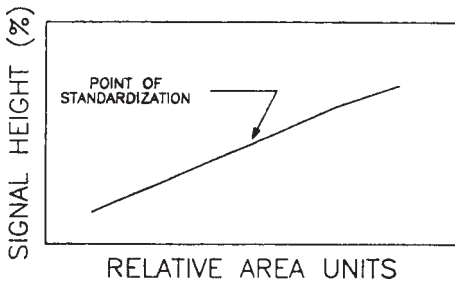

FIG. 7 Typical Area-Amplitude Ultrasonic Response Curve

examining sound beam. For the fabrication of reference standards of the types shown in Figs. 1-4, a common procedure involves the drilling of the chosen hole sizes to a desired depth using a conventional fluted drill bit. In Fig. 1 this depth would be $\frac{3}{4}$ in. The fluted drill bit, or another of the same size, is carefully ground to remove the point and square the tip. An optical comparator or tool maker's microscope is useful to determine when the point has been completely removed and the drill bit end is flat and square.

8.2.1 The flattened drill bit is then used to carefully flatten the bottom of the drilled hole. This operation normally requires great care to avoid drill breakage while still ensuring that the hole bottom is flat. A physician's ear examination microscope with a tip of the proper diameter is helpful in determining when the hole bottom is truly flat.

8.2.2 If the ultrasonic examination is to be conducted with the product (and therefore the reference block) immersed in a liquid, it is considered good practice to plug the flat-bottom holes in the reference block. Before plugging the holes it is important that the holes be free of debris and totally dry. Moisture, metal shavings, or both, can influence the ultrasonic response from the hole bottom.

8.2.3 When using metal plugs, counterbores are machined in the block to seat the plugs. An alternative method is to use plastic or rubber type sealant forced a short distance into the holes and allowed to harden.

8.3 *Diffusion Bonding Method*—The diffusion bonding technique offers an alternative method of reference block manufacture. With this method it is possible to fabricate reference blocks containing flat disc-shaped ultrasonic reflectors instead of flat-bottom holes. In many cases this permits the examination of the reference block from more than one direction thus enhancing the utility of the block.

8.3.1 A typical example is shown in Fig. 5. A diffusion-bonded reference block for small diameter rounds could be fabricated as shown. A section is removed from one of the round bars to be examined. The bar section is split lengthwise and both split surfaces are carefully ground. An endmill of the desired diameter is used to mill a shallow (typically $\frac{1}{2}$ the hole diameter in depth) flat-bottom hole in one of the split sections. The sections are then bonded back together using the diffusion bonding process. (The application of heat and pressure on the two sections for a period of time results in a sound diffusion bond which is indistinguishable metallographically or ultrasonically from the normal structure.) (See Note 2.) The result is a reference standard that can be examined from either of 2 sides.

NOTE 2—The time, temperature, and pressure requirements for a diffusion bond are both material and configuration dependent and therefore are beyond the scope of this guide. The American Welding Society⁴ can furnish information on the subject.

8.3.2 With developed skills, all of the reference blocks shown in Figs. 1-4 along with many more types can be successfully fabricated using the diffusion bonding technique.

9. Verification of Reflector Acceptability

9.1 It is often desirable or required by specification, or both, that the flat-bottom holes be proven to be of the proper size and flatness. A hole replication method is often used to measure these hole characteristics. This method, more often used for holes of $\frac{3}{64}$ in. or greater diameter, involves forcing a liquid rubber or plastic compound into the clean, dry hole, removing all entrapped air. When the material hardens it can be removed in the form of a plug or replica. This plug or hole replica can

⁴ American Welding Society, 550 NW LeJeune Rd., P.O. Box 351040, Miami, FL 33135.

then be examined for the proper size and flatness. The removal of the hardened plug is facilitated if a small wire or other object is inserted into the hole while the replicating material is still liquid. When the replicating material solidifies the wire serves as a handle permitting easy removal of the plug.

9.2 Replication of the disc-shaped reflector in diffusion bonded reference blocks is not possible. An alternative method of determining whether the reflector has been distorted by the bonding process is to fabricate a second block under identical conditions for destructive examination at the conclusion of the process.

10. Ultrasonic Response Characteristics

10.1 If the fabrication procedure, either drilling or diffusion bonding, was sufficiently accurate, then the distance amplitude reference block set may yield an ultrasonic response curve similar to that shown in Fig. 6. The shape of the curve may differ significantly with any change of test frequency, search unit diameter, couplant method or water path length. The

procedure used to obtain distance-amplitude curves for flat-entry-surface cylindrical FBH reference blocks is described in Practice E 428. A comparable ASTM procedure for curved-entry-surface reference blocks is not yet available.

10.2 An area-amplitude block set should yield a plot similar to that shown in Fig. 7. The shape of the curve may differ significantly and depends on test frequency, search unit diameter, couplant method, and water path length. The procedure for obtaining this curve for flat-entry-surface cylindrical FBH reference blocks is also presented in Practice E 428. A comparable ASTM procedure for curved-entry-surface reference blocks is not yet available.

11. Keywords

11.1 area-amplitude; diffusion bonding; distance-amplitude; flat-bottom hole; material selection; nondestructive testing; reference block; response curve; ultrasonic examination; ultrasound

ASTM International takes no position respecting the validity of any patent rights asserted in connection with any item mentioned in this standard. Users of this standard are expressly advised that determination of the validity of any such patent rights, and the risk of infringement of such rights, are entirely their own responsibility.

This standard is subject to revision at any time by the responsible technical committee and must be reviewed every five years and if not revised, either reapproved or withdrawn. Your comments are invited either for revision of this standard or for additional standards and should be addressed to ASTM International Headquarters. Your comments will receive careful consideration at a meeting of the responsible technical committee, which you may attend. If you feel that your comments have not received a fair hearing you should make your views known to the ASTM Committee on Standards, at the address shown below.

This standard is copyrighted by ASTM International, 100 Barr Harbor Drive, PO Box C700, West Conshohocken, PA 19428-2959, United States. Individual reprints (single or multiple copies) of this standard may be obtained by contacting ASTM at the above address or at 610-832-9585 (phone), 610-832-9555 (fax), or service@astm.org (e-mail); or through the ASTM website (www.astm.org).