



Standard Terminology for Nondestructive Examinations¹

This standard is issued under the fixed designation E 1316; the number immediately following the designation indicates the year of original adoption or, in the case of revision, the year of last revision. A number in parentheses indicates the year of last reapproval. A superscript epsilon (ϵ) indicates an editorial change since the last revision or reapproval.

INDEX OF TERMS

	Section	Page
A:	Common NDT Terms	2
B:	Acoustic Emission	3
C:	Electromagnetic Testing	7
D:	Gamma- and X-Radiology	40
D:	<u>Gamma- and X-Radiology</u>	<u>11</u>
E:	Leak Testing	15
F:	Liquid Penetrant Examination	20
F:	<u>Liquid Penetrant Examination</u>	<u>21</u>
G:	Magnetic Particle Examination	24
G:	<u>Magnetic Particle Examination</u>	<u>22</u>
H:	Neutron Radiology	24
H:	<u>Neutron Radiology</u>	<u>25</u>
I:	Ultrasonic Examination	25
I:	<u>Ultrasonic Examination</u>	<u>26</u>
J:	Infrared Examination	29
J:	<u>Infrared Examination</u>	<u>30</u>
K:	Optical Holography	34
K:	<u>Optical Holography</u>	<u>32</u>
L:	Visual and Optical Methods	32
L:	<u>Visual and Optical Methods</u>	<u>33</u>
	Appendix	32
	<u>Appendix</u>	<u>34</u>

1. Scope

1.1 This standard defines the terminology used in the standards prepared by the E07 Committee on Nondestructive Testing. These nondestructive testing (NDT) methods include: acoustic emission, electromagnetic testing, gamma- and X-radiology, leak testing, liquid penetrant examination, magnetic particle examination, neutron radiology and gaging, ultrasonic examination, and other technical methods.

1.2 Section A defines terms that are common to multiple NDT methods, whereas, the subsequent sections define terms pertaining to specific NDT methods. An alphabetical list of the terms defined in this standard is given in Appendix X1, which also identifies the section in which each term is defined.

1.3 As shown on the chart below, when nondestructive testing produces an indication, the indication is subject to interpretation as false, nonrelevant or relevant. If it has been interpreted as relevant, the necessary subsequent evaluation will result in the decision to accept or reject the material. With the exception of accept and reject, which retain the meaning found in most dictionaries, all the words used in the chart are defined in Section A.

¹ This terminology is under the jurisdiction of Committee E07 on Nondestructive Testing and is the direct responsibility of Subcommittee E07.92 on Editorial Review. Current edition approved August 10, 2003; February 1, 2004. Published October 2003; March 2004. Originally approved in 1989. Last previous edition approved in 2002³ as E 1316 – 02a³.

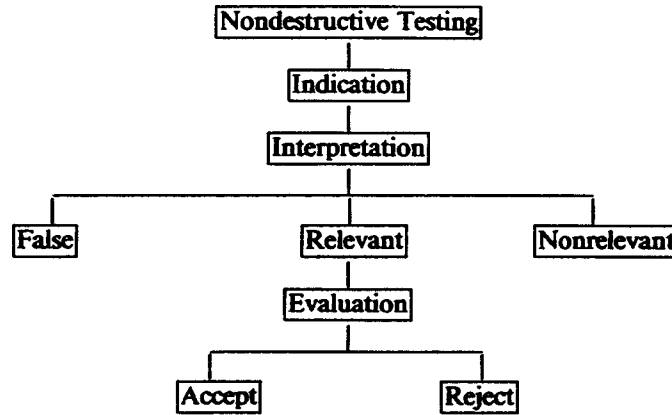

2. Referenced Documents

2.1 ASTM Standards: ²

- E 94 Guide for Radiographic Examination
- E 127 Practice for Fabricating and Checking Aluminum Alloy Ultrasonic Standard Reference Blocks
- E 215 Practice for Standardizing Equipment for Electromagnetic Examination of Seamless Aluminum-Alloy Tube
- E 494 Practice for Measuring Ultrasonic Velocity in Materials
- E 566 Practice for Electromagnetic (Eddy-Current) Sorting of Ferrous Metals
- E 664 Practice for Measurement of the Apparent Attenuation of Longitudinal Ultrasonic Waves by Immersion Method
- E 750 Practice for Characterizing Acoustic Emission Instrumentation
- E 804 Practice for Calibration of the Ultrasonic Test System by Extrapolation Between Flat Bottom Hole Sizes
- E 1033 Practice for Electromagnetic (Eddy-Current) Examination of Type F-Continuously Welded (CW) Ferromagnetic Pipe and Tubing Above the Curie Temperature
- E 1067 Practice for Acoustic Emission Examination of Fiberglass Reinforced Plastic Resin (FRP) Tanks/Vessels
- E 1118 Practice for Acoustic Emission Examination of Reinforced Thermosetting Resin Pipe (RTRP)
- E 1213 Test Method for Minimum Resolvable Temperature Difference for Thermal Imaging Systems

3. Significance and Use

3.1 The terms found in this standard are intended to be used uniformly and consistently in all nondestructive testing standards. The purpose of this standard is to promote a clear understanding and interpretation of the NDT standards in which they are used.

² For referenced ASTM standards, visit the ASTM website, www.astm.org, or contact ASTM Customer Service at service@astm.org. For Annual Book of ASTM Standards, Vol 03-03, volume information, refer to the standard's Document Summary page on the ASTM website.

Section A: Common NDT Terms

The terms defined in Section A are the direct responsibility of Subcommittee E07.92, Editorial Review.

4. Terminology

acceptable quality level—the maximum percent defective or the maximum number of units defective per hundred units that, for the purpose of sampling test, can be considered satisfactory as a process average.

calibration, instrument, n—the comparison of an instrument with, or the adjustment of an instrument to, a known reference(s) often traceable to the National Institute of Standards and Technology (NIST). (See also **standardization, instrument**.)

cognizant engineering organization—the company, government agency or other authority responsible for the design, or end use, of the material or component for which nondestructive testing is required

DISCUSSION—In addition to design personnel, the cognizant engineering organization could include personnel from engineering, material and process engineering, stress analysis, nondestructive testing, quality assurance and others, as appropriate.

defect, n—one or more flaws whose aggregate size, shape, orientation, location, or properties do not meet specified acceptance criteria and are rejectable.

discontinuity, n—a lack of continuity or cohesion; an intentional or unintentional interruption in the physical structure or configuration of a material or component.

evaluation—determination of whether a relevant indication is cause to accept or to reject a material or component.

examination, n—a procedure for determining a property (or properties) or other conditions or characteristics of a material or component by direct or indirect means.

NOTE 1—Examples include utilization of X rays or ultrasonic waves for the purpose of determining (directly or by calculation) flaw content, density, or (for ultrasound) modulus; or detection of flaws by induction of eddy currents, observing thermal behavior, AE response, or utilization of magnetic particles or liquid penetrants.

false indication, n—an NDT indication that is interpreted to be caused by a condition other than a discontinuity or imperfection.

flaw, n—an imperfection or discontinuity that may be detectable by nondestructive testing and is not necessarily rejectable.

flaw characterization, n—the process of quantifying the size, shape, orientation, location, growth, or other properties, of a flaw based on NDT response.

imperfection, n—a departure of a quality characteristic from its intended condition.

indication—the response or evidence from a nondestructive examination.

DISCUSSION—An indication is determined by interpretation to be relevant, non-relevant, or false.

inspection, n—a procedure for viewing or observing visual characteristics of a material or component in a careful, critical manner.

NOTE 2—Examples include performance of a visual/optical inspection, observing the results of a magnetic particle or liquid penetrant examination, or carefully observing a surface condition prior to performing an ultrasonic or eddy-current examination. (From the same root word as “spectacle” or “spectator”.)

interpretation—the determination of whether indications are relevant or nonrelevant.

interpretation, n—the determination of whether indications are relevant, nonrelevant, or false.

Nondestructive Evaluation— see **Nondestructive Testing**.

Nondestructive Examination— see **Nondestructive Testing**.

Nondestructive Inspection— see **Nondestructive Testing**.

Nondestructive Testing (NDT), n—the development and application of technical methods to examine materials or components in ways that do not impair future usefulness and serviceability in order to detect, locate, measure and evaluate flaws; to assess integrity, properties and composition; and to measure geometrical characteristics.

nonrelevant indication, n—an NDT indication that is caused by a condition or type of discontinuity that is not rejectable. False indications are non-relevant.

relevant indication, n—an NDT indication that is caused by a condition or type of discontinuity that requires evaluation.

standardization, instrument, n—the adjustment of an NDT instrument using an appropriate reference standard, to obtain or establish a known and reproducible response. (This is usually done prior to an examination, but can be carried out anytime there is concern about the examination or instrument response. (See also **calibration, instrument**.)

test, n—a procedure for determining a property or characteristic of a material or a component by direct measurement.

NOTE 3—Examples include mechanical tests to determine strength, hardness, or other property; determination of leakage (a leak test); or checking the performance (function) of a piece of equipment.

Section B: Acoustic Emission (E 750, E 1067, and E 1118)

The boldface designations in parentheses indicate the standards from which the terms in that section were derived.

The terms defined in Section B are the direct responsibility of Subcommittee E07.04 on Acoustic Emission Method.

acoustic emission (AE)—the class of phenomena whereby transient elastic waves are generated by the rapid release of energy from localized sources within a material, or the transient waves so generated. Acoustic emission is the recommended term for general use. Other terms that have been used in AE literature include (1) stress wave emission, (2) microseismic activity, and (3) emission or acoustic emission with other qualifying modifiers.

acoustic emission channel— see **channel, acoustic emission**.

acoustic emission count (emission count) (N)—see **count, acoustic emission**.

acoustic emission count rate—see **count rate, acoustic emission (emission rate or count rate) (\dot{N})**.

acoustic emission event— see **event, acoustic emission**.

acoustic emission event energy—see **energy, acoustic event**.

acoustic emission sensor— see **sensor, acoustic emission**.

acoustic emission signal amplitude—see **signal amplitude, acoustic emission**.

acoustic emission signal (emission signal)—see **signal, acoustic emission**.

acoustic emission signature (signature)—see **signature, acoustic emission**.

acoustic emission transducer—see **sensor, acoustic emission**.

acoustic emission waveguide—see **waveguide, acoustic emission**.

acousto-ultrasonics (AU)—a nondestructive examination method that uses induced stress waves to detect and assess diffuse defect states, damage conditions, and variations of mechanical properties of a test structure. The AU method combines aspects of acoustic emission (AE) signal analysis with ultrasonic materials characterization techniques.

adaptive location—source location by iterative use of simulated sources in combination with computed location.

AE activity, *n*—the presence of acoustic emission during a test.

AE amplitude— see **dB_{AE}**.

AE rms, *n*—the rectified, time averaged AE signal, measured on a linear scale and reported in volts.

AE signal duration—the time between AE signal start and AE signal end.

AE signal end—the recognized termination of an AE signal, usually defined as the last crossing of the threshold by that signal.

AE signal generator—a device which can repeatedly induce a specified transient signal into an AE instrument.

AE signal rise time—the time between AE signal start and the peak amplitude of that AE signal.

AE signal start—the beginning of an AE signal as recognized by the system processor, usually defined by an amplitude excursion exceeding threshold.

array, *n*—a group of two or more AE sensors positioned on a structure for the purposes of detecting and locating sources. The sources would normally be within the array.

arrival time interval (Δt_{ij})—see **interval, arrival time**.

attenuation, *n*—the decrease in AE amplitude per unit distance, normally expressed in dB per unit length.

average signal level, *n*—the rectified, time averaged AE logarithmic signal, measured on the AE amplitude logarithmic scale and reported in dB_{ae} units (where 0 dB_{ae} refers to 1 μV at the preamplifier input).

burst emission—see **emission, burst**.

channel, acoustic emission—an assembly of a sensor, preamplifier or impedance matching transformer, filters secondary amplifier or other instrumentation as needed, connecting cables, and detector or processor.

NOTE 4—A channel for examining fiberglass reinforced plastic (FRP) may utilize more than one sensor with associated electronics. Channels may be processed independently or in predetermined groups having similar sensitivity and frequency characteristics.

continuous emission— see **emission, continuous**.

count, acoustic emission (emission count) (N)—the number of times the acoustic emission signal exceeds a preset threshold during any selected portion of a test.

count, event (N_e)—the number obtained by counting each discerned acoustic emission event once.

count rate, acoustic emission (emission rate or count rate) (Ṅ) —the time rate at which emission counts occur.

count, ring-down—see **count, acoustic emission**, the preferred term.

couplant—a material used at the structure-to-sensor interface to improve the transmission of acoustic energy across the interface during acoustic emission monitoring.

cumulative (acoustic emission) amplitude distribution $F(V)$ —see **distribution, amplitude, cumulative**.

cumulative (acoustic emission) threshold crossing distribution $F_t(V)$ — see **distribution, threshold crossing, cumulative**.

dB_{AE}—a logarithmic measure of acoustic emission signal amplitude, referenced to 1 μV at the sensor, before amplification.

$$\text{Signal peak amplitude (dB}_{AE}) = (dB_{1\mu V \text{ at sensor}}) = 20 \log_{10}(A_1/A_0) \quad (1)$$

where:

A_0 = 1 μV at the sensor (before amplification), and

A_1 = peak voltage of the measured acoustic emission signal (also before amplification).

Acoustic Emission Reference Scale:

dB _{AE} Value	Voltage at Sensor
0	1 μV
20	10 μV
40	100 μV
60	1 mV
80	10 mV
100	100 mV

DISCUSSION—In the case of sensors with integral preamplifiers, the A_0 reference is before internal amplification.

dead time—any interval during data acquisition when the instrument or system is unable to accept new data for any reason. (E 750)³

differential (acoustic emission) amplitude distribution $F(V)$ —see **distribution, differential (acoustic emission) amplitude $f(V)$** .

differential (acoustic emission) threshold crossing distribution $f_t(V)$ — see **distribution, differential (acoustic emission) threshold crossing**.

³ Discontinued. See 1993 Annual Book of

³ The designations in parentheses following the terms indicate the ASTM Standards, Vol 03.03, standards from which the terms were derived.

distribution, amplitude, cumulative (acoustic emission) $F(V)$ —the number of acoustic emission events with signals that exceed an arbitrary amplitude as a function of amplitude V .

distribution, threshold crossing, cumulative (acoustic emission) $F_t(V)$ —the number of times the acoustic emission signal exceeds an arbitrary threshold as a function of the threshold voltage (V).

distribution, differential (acoustic emission) amplitude $f(V)$ —the number of acoustic emission events with signal amplitudes between amplitudes of V and $V + \Delta V$ as a function of the amplitude V . $f(V)$ is the absolute value of the derivative of the cumulative amplitude distribution $F(V)$.

distribution, differential (acoustic emission) threshold crossing $f_t(V)$ —the number of times the acoustic emission signal waveform has a peak between thresholds V and $V + \Delta V$ as a function of the threshold V . $f_t(V)$ is the absolute value of the derivative of the cumulative threshold crossing distribution $F_t(V)$.

distribution, logarithmic (acoustic emission) amplitude $g(V)$ —the number of acoustic emission events with signal amplitudes between V and αV (where α is a constant multiplier) as a function of the amplitude. This is a variant of the differential amplitude distribution, appropriate for logarithmically windowed data.

dynamic range—the difference, in decibels, between the overload level and the minimum signal level (usually fixed by one or more of the noise levels, low-level distortion, interference, or resolution level) in a system or sensor.

effective velocity, n —velocity calculated on the basis of arrival times and propagation distances determined by artificial AE generation; used for computed location.

emission, burst—a qualitative description of the discrete signal related to an individual emission event occurring within the material.

NOTE 5—Use of the term burst emission is recommended only for describing the qualitative appearance of emission signals. Fig. 1 shows an oscilloscope trace of burst emission signals on a background of continuous emission.

emission, continuous—a qualitative description of the sustained signal level produced by rapidly occurring acoustic emission from structural sources, leaks, or both.

NOTE 6— Use of the term *continuous emission* is recommended only for describing the qualitative appearance of emission signals. Fig. 2 and Fig. 3 show oscilloscope traces of continuous emission signals at two different sweep rates.

energy, acoustic emission event—the total elastic energy released by an emission event.

energy, acoustic emission signal—the energy contained in a detected acoustic emission burst signal, with units usually reported in joules and values which can be expressed in logarithmic form (dB, decibels).

evaluation threshold—a threshold value used for analysis of the examination data. Data may be recorded with a *system examination threshold* lower than the *evaluation threshold*. For analysis purposes, dependence of measured data on the *system examination threshold* must be taken into consideration.

event, acoustic emission (emission event)— a local material change giving rise to acoustic emission.

event count (N_e)—see **count, event**.

event count rate (N_e)— see **rate, event count**.

examination area—that portion of a structure being monitored with acoustic emission.

examination region—that portion of the test article evaluated using acoustic emission technology.

Felicity effect—the presence of acoustic emission, detectable at a fixed predetermined sensitivity level at stress levels below those previously applied. (E 1067)

Felicity effect—the presence of detectable acoustic emission at a fixed predetermined sensitivity level at stress levels below those previously applied.

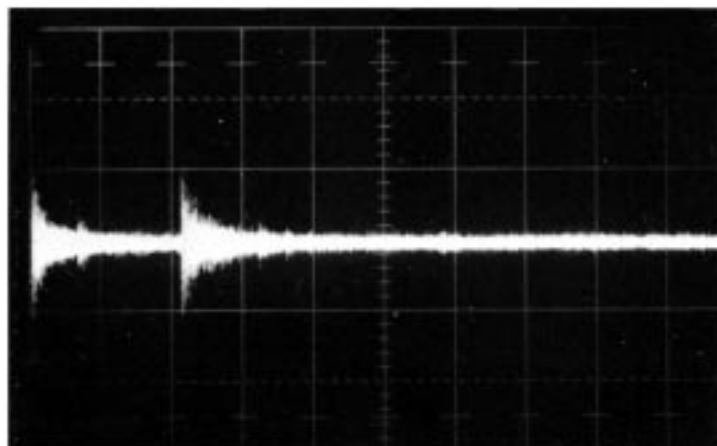

FIG. 1 Burst Emission on a Continuous Emission Background. (Sweep Rate—5 ms/cm.)

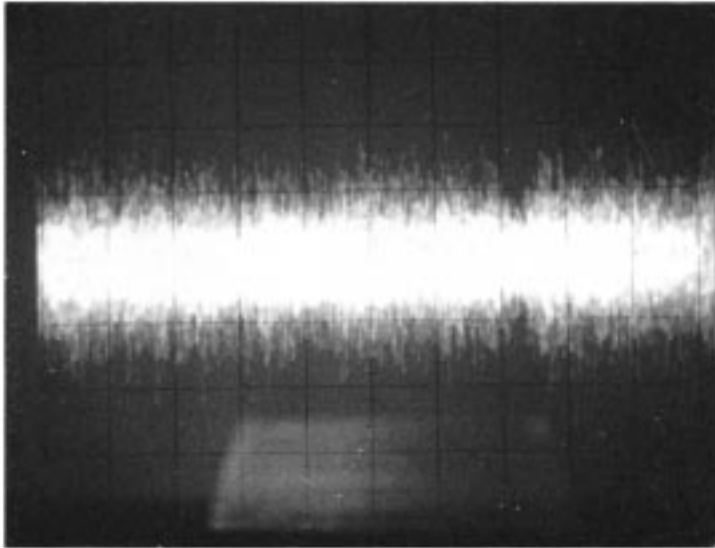

FIG. 2 Continuous Emission. (Sweep Rate—5 ms/cm.)

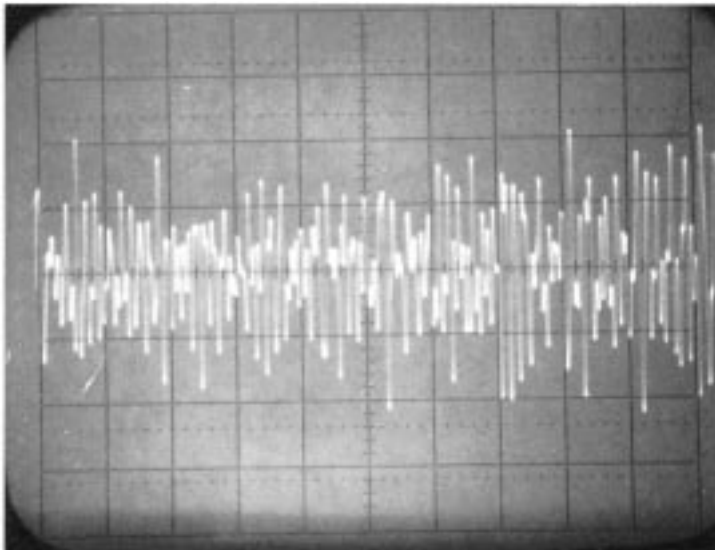

FIG. 3 Continuous Emission. (Sweep Rate—0.1 ms/cm.)

Felicity ratio—the ratio of the stress at which the Felicity effect occurs to the previously applied maximum stress. (E 1067, E 1118)

NOTE 7—The fixed sensitivity level will usually be the same as was used for the previous loading or test. (E 1118)

instrumentation dead time— see **dead time, instrumentation**.

first hit location—a zone location method defined by which a channel among a group of channels first detects the signal.

floating threshold—any threshold with amplitude established by a time average measure of the input signal. (E 750)

hit—the detection and measurement of an AE signal on a channel.

interval, arrival time (Δt_{ij})—the time interval between the detected arrivals of an acoustic emission wave at the *i*th and *j*th sensors of a sensor array.

Kaiser effect—the absence of detectable acoustic emission at a fixed sensitivity level, until previously applied stress levels are exceeded.

location accuracy, *n*—a value determined by comparison of the actual position of an AE source (or simulated AE source) to the computed location.

location, cluster, *n*—a location technique based upon a specified amount of AE activity located within a specified length or area, for example: 5 events within 12 linear inches or 12 square inches.

location, computed, *n*—a source location method based on algorithmic analysis of the difference in arrival times among sensors.

NOTE 8—Several approaches to computed location are used, including linear location, planar location, three dimensional location, and adaptive

location.

- (a) *linear location, n*—one dimensional source location requiring two or more channels.
- (b) *planar location, n*—two dimensional source location requiring three or more channels.
- (c) *3D location, n*—three dimensional source location requiring five or more channels.
- (d) *adaptive location, n*—source location by iterative use of simulated sources in combination with computed location.

location, continuous AE signal, n—a method of location based on continuous AE signals, as opposed to hit or difference in arrival time location methods.

NOTE 9—This type of location is commonly used in leak location due to the presence of continuous emission. Some common types of continuous signal location methods include signal attenuation and correlation analysis methods.

- (a) *signal attenuation-based source location, n*—a source location method that relies on the attenuation versus distance phenomenon of AE signals. By monitoring the AE signal magnitudes of the continuous signal at various points along the object, the source can be determined based on the highest magnitude or by interpolation or extrapolation of multiple readings.
- (b) *correlation-based source location, n*—a source location method that compares the changing AE signal levels (usually waveform based amplitude analysis) at two or more points surrounding the source and determines the time displacement of these signals. The time displacement data can be used with conventional hit based location techniques to arrive at a solution for the source site.

location, source, n—any of several methods of evaluating AE data to determine the position on the structure from which the AE originated. Several approaches to source location are used, including zone location, computed location, and continuous location.

location, zone, n—any of several techniques for determining the general region of an acoustic emission source (for example, total AE counts, energy, hits, and so forth).

NOTE 10—Several approaches to zone location are used, including independent channel zone location, first hit zone location, and arrival sequence zone location.

- (a) *independent channel zone location, n*—a zone location technique that compares the gross amount of activity from each channel.
- (b) *first-hit zone location, n*—a zone location technique that compares only activity from the channel first detecting the AE event.
- (c) *arrival sequence zone location, n*—a zone location technique that compares the order of arrival among sensors.

logarithmic (acoustic emission) amplitude distribution $g(V)$ —see **distribution, logarithmic (acoustic emission) amplitude**.

overload recovery time—an interval of nonlinear operation of an instrument caused by a signal with amplitude in excess of the instrument's linear operating range.

performance check, AE system—see **verification, AE system**.

pressure, design—pressure used in design to determine the required minimum thickness and minimum mechanical properties.

processing capacity—the number of hits that can be processed at the processing speed before the system must interrupt data collection to clear buffers or otherwise prepare for accepting additional data.

processing speed—the sustained rate (hits/s), as a function of the parameter set and number of active channels, at which AE signals can be continuously processed by a system without interruption for data transport.

rate, event count (Ne)—the time rate of the event count.

rearm delay time—see **time, rearm delay**.

ring-down count—see **count, acoustic emission, the preferred term**.

sensor, acoustic emission—a detection device, generally piezoelectric, that transforms the particle motion produced by an elastic wave into an electrical signal.

signal, acoustic emission (emission signal)—an electrical signal obtained by detection of one or more acoustic emission events.

signal amplitude, acoustic emission—the peak voltage of the largest excursion attained by the signal waveform from an emission event.

signal overload level—that level above which operation ceases to be satisfactory as a result of signal distortion, overheating, or damage.

signal overload point—the maximum input signal amplitude at which the ratio of output to input is observed to remain within a prescribed linear operating range.

signal strength—the measured area of the rectified AE signal with units proportional to volt-sec.

DISCUSSION—The proportionality constant is specified by the AE instrument manufacturer.

signature, acoustic emission (signature)—a characteristic set of reproducible attributes of acoustic emission signals associated with a specific test article as observed with a particular instrumentation system under specified test conditions.

stimulation—the application of a stimulus such as force, pressure, heat, etc., to a test article to cause activation of acoustic emission sources.

system examination threshold—the electronic instrument threshold (see **evaluation threshold**) which data will be detected.

transducers, acoustic emission—see **sensor, acoustic emission**.

verification, AE system (performance check, AE system)—the process of testing an AE system to assure conformance to a specified level of performance or measurement accuracy. (This is usually carried out prior to, during and/or after an AE examination with the AE system connected to the examination object, using a simulated or artificial acoustic emission source.)

voltage threshold—a voltage level on an electronic comparator such that signals with amplitudes larger than this level will be recognized. The voltage threshold may be user adjustable, fixed, or automatic floating. (E 750)

waveguide, acoustic emission—a device that couples elastic energy from a structure or other test object to a remotely mounted sensor during AE monitoring. An example of an acoustic emission waveguide would be a solid wire of rod that is coupled at one end to a monitored structure, and to a sensor at the other end.

Section C: Electromagnetic Testing (E 215, E 243, E 566, E 1033)

The terms defined in Section C are the direct responsibility of Subcommittee E07.07 on Electromagnetic Methods.

absolute coil—a coil (or coils) that respond(s) to the total detected electric or magnetic properties, or both, of a part or section of the test part without comparison to another section of the part or to another part. (E 566)

absolute measurements—in electromagnetic testing, measurements made without a direct reference using an absolute coil in contrast to differential and comparative measurements. (See also **absolute coil**).

absolute readout—in electromagnetic testing, the signal output of an absolute coil. (See also **absolute coil**.)

absolute system—a system that uses a coil assembly and associated electronics to measure the total electromagnetic properties of a test part without direct comparison to another section of the part or to another part (see **absolute coil**.) (E 566)

acceptance level—a test level above or below which test specimens are acceptable in contrast to rejection level.

acceptance limits—test levels used in electromagnetic sorting which establish the group into which the material under test belongs. (E 566)

acceptance standard—a tube with artificial discontinuities specified in the applicable product standard used to establish the acceptance level. (E 215)

acceptance standard—in tubing inspection, a tube used to establish the acceptance level with artificial discontinuities as specified in the applicable product standard.

amplitude distortion— same as **harmonic distortion**.

amplitude response—that property of a test system whereby the amplitude of the detected signal is measured without regard to phase. (See also **harmonic analysis and phase analysis** .)

annular coil clearance—the mean radial distance between adjacent coil assembly and test part surface in electromagnetic encircling coil examination.

annular coils—see **encircling coils**.

artificial discontinuity—reference discontinuities, such as holes, grooves, or notches that are introduced into a reference standard to provide accurately reproducible sensitivity levels for electromagnetic test equipment.

band pass filter—a wave filter having a single transmission band; neither of the cut-off frequencies being zero or infinity.

bobbin coil—see **ID coil**.

bucking coils—same as **differential coils**.

circumferential coils— see **encircling coils**.

coil, absolute— see **absolute coil**.

coil, reference— see **reference coil**.

coil size—the dimension of a coil, for example, length or diameter.

coil spacing—in electromagnetic testing, the axial distance between two encircling coils of a differential system.

coil, test—in electromagnetic testing, the section of the probe or coil assembly that excites or detects, or both, the electromagnetic field in the material under test.

comparative measurements—in electromagnetic testing, measurements made in which the unbalance in the system is measured using comparator coils in contrast to differential and absolute measurements. (See also **comparator coils**.)

comparative readout—in electromagnetic testing, the signal output of comparator coils. (See also **comparator coils**.)

comparative system—a system that uses coil assemblies and associated electronics to detect any electric or magnetic condition, or both, that is not common to the test specimen and the standard (see **comparator coils**). (E 566)

comparator coils—in electromagnetic testing, two or more coils electrically connected in series opposition but arranged so that there is no mutual induction (coupling) between them such that any electric or magnetic condition, or both, that is not common to the test specimen and the standard, will produce an unbalance in the system and thereby yield an indication.

conductivity—the intrinsic property of a particular material to carry electric current; it is commonly expressed in percent IACS (International Annealed Copper Standard) or MS/m (MegaSiemens/metre).

coupling—two electric circuits are said to be coupled to each other when they have an impedance in common so that a current in one causes a voltage in the other.

cut-off level—same as **rejection level**.

defect resolution—a property of a test system that enables the separation of indications due to defects in a test specimen that are located in close proximity to each other.

depth of penetration—in electromagnetic testing, the depth at which the magnetic field strength or intensity of induced eddy currents has decreased to 37 % of its surface value. The depth of penetration is an exponential function of the frequency of the

signal and the conductivity and permeability of the material. Synonymous terms are standard depth of penetration and skin depth. (See also **skin effect** .)

diamagnetic material—a material whose relative permeability is less than unity.

NOTE 11—The intrinsic induction B_i is oppositely directed to the applied magnetizing force H .

differential coils—two or more coils electrically connected in series opposition such that any electric or magnetic condition, or both, that is not common to the areas of a specimen being electromagnetically tested will produce an unbalance in the system and thereby yield an indication.

differential measurements—in electromagnetic testing, measurements made in which the imbalance in the system is measured using differential coils in contrast to absolute and comparative measurements. (See also **differential coils**.)

differential readout—in electromagnetic testing, the signal output of differential coils. (See also **differential coils**.)

differential signal—in electromagnetic testing, an output signal that is proportional to the rate of change of the input signal.

differential system—an electromagnetic testing system that uses coil assemblies and associated electronics to detect an electric or magnetic condition, or both, that is not common to the areas of the specimen being tested. (See also **differential coils** .)

eddy current—an electrical current caused to flow in a conductor by the time or space variation, or both, of an applied magnetic field.

eddy current testing—a nondestructive testing method in which eddy current flow is induced in the test object. Changes in the flow caused by variations in the specimen are reflected into a nearby coil, coils, or Hall effect device for subsequent analysis by suitable instrumentation and techniques.

edge effect—in electromagnetic testing, the disturbance of the magnetic field and eddy-currents due to the proximity of an abrupt change in specimen geometry (edge). This effect generally results in the masking of discontinuities within the affected region. (This effect is also termed the **end effect**.)

effective depth penetration (EDP)—in electromagnetic testing, for (a) thickness, the minimum depth beyond which a test system can no longer reliably detect a further increase in specimen thickness, or (b) defects, the limit for reliably detecting metallurgical or mechanical discontinuities by way of conventional continuous wave (CW) eddy current instrumentation and sensors. The EDP point is approximately three times the standard depth of penetration.

effective permeability—a hypothetical quantity that describes the magnetic permeability that is experienced under a given set of physical conditions such as a cylindrical test specimen in an encircling coil at a specific test frequency. This quantity may be different from the permeability of the particular metal being tested in that it takes into account such things as the geometry of the part, the relative position of the encircling coil, and characteristics of the magnetic field.

electrical center—the center established by the electromagnetic field distribution within a test coil. A constant intensity signal, irrespective of the circumferential position of a discontinuity, is indicative of electrical centering. The electrical center may be different from the physical center of the test coil.

electromagnetic testing—a nondestructive test method for materials, including magnetic materials, that uses electromagnetic energy having frequencies less than those of visible light to yield information regarding the quality of testing material.

encircling coils—in electromagnetic testing, coil(s) or coil assembly that surround(s) the part to be tested. Coils of this type are also referred to as annular, circumferential, or feed-through coils.

end effect—see **edge effect**.

end effect—the loss in sensitivity to discontinuities located near the extreme ends of the tube as the ends of the tube enter or leave the test coil. (E 215)

feed-through coils— see **encircling coils**.

ferromagnetic material—a material that, in general, exhibits the phenomena of magnetic hysteresis and saturation, and whose permeability is dependent on the magnetizing force.

fill factor—for internal probe electromagnetic testing, the ratio of the effective cross-sectional area of the primary internal probe coil to the cross-sectional area of the tube interior.

fill factor—for encircling coil electromagnetic testing, the ratio of the cross-sectional area of the test specimen to the effective cross-sectional core area of the primary encircling coil (outside diameter of coil form, not inside diameter which is adjacent to specimen).

filter—a network that passes electromagnetic wave energy over a described range of frequencies and attenuates energy at all other frequencies.

frequency—the number of cycles per second of alternating electric current induced into the tubular product. For eddy-current testing described herein, the frequency is normally 1 to 125 kHz, inclusive. (E 215)

gate—same as **rejection level**.

harmonic analysis—an analytical technique whereby the amplitude or phase, or both, of the frequency components of a complex periodic signal is determined.

harmonic distortion—nonlinear distortion characterized by the appearance in the output of harmonics other than the fundamental component when the input wave is sinusoidal.

IACS—the International Annealed Copper Standard; an international standard of electrical conductivity.

ID coil—a coil or coil assembly used for electromagnetic testing by insertion into the test piece as in the case of an inside probe

for tubing. Coils of this type are also referred to as inside coils, inserted coils, or bobbin coils.

impedance—the total opposition that a circuit presents to the flow of an alternating current, specifically the complex quotient of voltage divided by current.

impedance analysis—in electromagnetic testing, an analytical method that consists of correlating changes in the amplitude, phase, or quadrature components, or all of these, of a complex test signal voltage to the electromagnetic conditions within the test specimen.

impedance plane diagram—a graphical representation of the locus of points, indicating the variations in the impedance of a test coil as a function of basic test parameters.

incremental permeability—the ratio of the change in magnetic induction to the corresponding change in magnetizing force when the mean induction differs from zero.

indications—eddy-current signals caused by any change from uniformity of a tube. These changes from uniformity affect the electrical characteristic of the tube but may not be detrimental to the end use of the product. (E 215)

initial permeability—the slope of the induction curve at zero magnetizing force as the test specimen is being removed from a demagnetizing condition (slope at origin of BH curve before hysteresis is observed).

inserted coil—see **ID coil**.

inside coil—see **ID coil**.

lift-off effect—the effect observed in an electromagnetic test system output due to a change in magnetic coupling between a test specimen and a probe coil whenever the distance between them is varied.

magnetic history—magnetic condition of a ferromagnetic part under test based on previous exposures to magnetic fields. (E 566)

magnetic leakage flux—the excursion of magnetic lines of force from the surface of a test specimen.

magnetic saturation—that degree of magnetization where a further increase in magnetizing force produces no significant increase in magnetic flux density (permeability) in a specimen.

modulation analysis—an analytical method used in electromagnetic testing that separates responses due to various factors influencing the total magnetic field by separating and interpreting, individually, frequencies or frequency bands in the modulation envelope of the (carrier frequency) signal.

noise—in electromagnetic inspection, any nonrelevant signal that tends to interfere with the normal reception or processing of a desired flaw signal. It should be noted that such noise signals may be generated by inhomogeneities in the inspected part that are not detrimental to the end use of the part.

nonferromagnetic material—a material that is not magnetizable and hence, essentially not affected by magnetic fields. This would include paramagnetic materials and diamagnetic materials.

normal permeability—the ratio of the induction (when cyclically made to change symmetrically about zero) to the corresponding change in magnetizing force.

off-line testing—eddy current tests conducted on equipment that includes the test coil and means to propel individual tubes under test through the coil at appropriate speeds and conditions.

on-line testing—eddy current tests conducted on equipment that includes the test coil and means to propel tubes under test through the coil at appropriate speeds and conditions as an integral part of a continuous tube manufacturing sequence.

optimum frequency—in electromagnetic testing, that frequency which provides the largest signal-to-noise ratio obtainable for the detection of an individual material property. Each property of a given material may have its own optimum frequency.

paramagnetic material—a material that has a relative permeability slightly greater than unity and that is practically independent of the magnetizing force.

permeability, a-c—a generic term used to express various dynamic relationships between magnetic induction, B , and magnetizing force, H , for magnetic material subjected to a cyclic excitation by alternating or pulsating current. The values of a-c permeability obtained for a given material depend fundamentally upon the excursion limits of dynamic excitation and induction, the method and conditions of measurement, and also upon such factors as resistivity, thickness of laminations, frequency of excitation, etc.

NOTE 12—The numerical value for any permeability is meaningless unless the corresponding B or H excitation level is specified. For incremental permeabilities not only must the corresponding d-c B or H excitation level be specified, but also the dynamic range (ΔB or ΔH).

permeability, d-c—permeability is a general term used to express relationships between magnetic induction, B , and magnetizing force, H , under various conditions of magnetic excitation. These relationships are either (1) absolute permeability, which in general is the quotient of a change in magnetic induction divided by the corresponding change in magnetizing force, or (2) relative permeability, which is the ratio of the absolute permeability to the magnetic constant (γ_m).

NOTE 13—The magnetic constant γ_m is a scalar quantity differing in value and uniquely determined by each electromagnetic system of units. In the unratonalized cgs system γ_m is 1 gauss/oersted and the mksa rationalized system $\gamma_m = 4\pi \times 10^{-7}$ H/m.

NOTE 14—Relative permeability is a pure number which is the same in all unit systems. The value and dimension of absolute permeability depends on the system of units employed.

NOTE 15—For any ferromagnetic material, permeability is a function of the degree of magnetization. However, initial permeability, μ_o , and maximum permeability, μ_m , are unique values for a given specimen under specified conditions.

NOTE 16—Except for initial permeability, μ_o , a numerical value for any of the d-c permeabilities is meaningless unless the corresponding B or H excitation level is specified.

NOTE 17—For the incremental permeabilities $\mu\Delta$ and $\mu\Delta i$, a numerical value is meaningless unless both the corresponding values of mean excitation level (B or H) and the excursion range (ΔB or ΔH) are specified.

phase analysis—an analytical technique that discriminates between variables in a part undergoing electromagnetic testing part by the different phase angle changes that these conditions produce in the test signal. (See also **phase detection**.)

phase angle—the angular equivalent of the time displacement between corresponding points on two sine waves of the same frequency.

phase detection—the derivation of a signal whose amplitude is a function of the phase angle between two alternating currents, one of which is used as a reference.

phase-sensitive system—a system whose output signal is dependent on the phase relationship between the voltage returned from a pickup or sensing coil and a reference voltage.

phase shift—a change in the phase relationship between two alternating quantities of the same frequency.

probe coil—in electromagnetic testing, a small coil or coil assembly that is placed on or near the surface of test objects.

probe coil clearance—the perpendicular distance between adjacent surfaces of the probe and test part; also lift-off.

recovery time—the time required for a test system to return to its original state after it has received a signal.

reference coil—a coil or probe, which may be used in conjunction with the appropriate material, to electrically balance a comparative system.

reference standard—a tube, plate or part with artificial discontinuities used for establishing the test sensitivity setting and for periodically checking and adjusting sensitivity setting as required. (See also **standard (1)**.) (E 215)

rejection level—the value established for a test signal above or below which test specimens are rejectable, or otherwise distinguished from the remaining specimens.

selectivity—the characteristic of a test system that is a measure of the extent to which an instrument is capable of differentiating between the desired signal and disturbances of other frequencies or phases.

sensitivity control—the control in the instrument that adjusts the amplifier gain, and is one of the factors that determines the capacity to detect discontinuities. (E 215)

signal gradient—same as **differential readout**.

signal-to-noise ratio—the ratio of values to signal (response containing relevant information) to that of noise (response containing nonrelevant information).

skin depth—see **depth of penetration**.

skin effect—the phenomenon wherein the depth of penetration of electric currents into a conductor decreases as the frequency of the current is increased. At very high frequencies, the current flow is restricted to an extremely thin outer layer of the conductor. (See also **depth of penetration**.)

speed effect—the phenomenon in electromagnetic testing of which the evidence is a change in the signal voltage resulting from a change in the relative motion between the specimen and a test coil assembly.

standard—(1) a physical reference used as a basis for comparison or calibration; (2) a concept that has been established by authority, custom, or agreement to serve as a model or rule in the measurement of quality or the establishment of a practice or procedure.

standard depth of penetration—see **depth of penetration**.

standard depth of penetration (SDP)—the depth at which the eddy current density is reduced to approximately 37 % of the density at the surface. Eddy-current testing is most effective when the wall thickness does not exceed the SDP or in heavier tube walls when discontinuities of interest are within one SDP. (E 215)

test coil—the section of the coil assembly that examines the material under test in a comparative system; the coil used to examine the material in an absolute or differential comparative system. (E 566)

test frequency—in electromagnetic testing, the number of complete cycles per unit time of the alternating current applied to the primary test coil.

test quality level— see **rejection level**.

three way sort—an electromagnetic sort based on a signal response from the material under test above or below two levels established by three or more calibration standards.

threshold level—the setting of an instrument that causes it to register only those changes in response greater or less than a specified magnitude.

threshold setting—the setting of the instrument that causes it to register only those changes in eddy-current response greater than a specified magnitude. (E 215)

NOTE 18—Sensitivity and threshold settings usually are indicated by arbitrary numbers on the control panel of the testing instrument. These numerical settings differ among instruments of different types. It is, therefore, not proper to translate a numerical setting on one instrument to that of another type. Even among instruments of the same design and from the same manufacturer, sensitivity and threshold settings may vary slightly when detecting the same discontinuity. Therefore, undue emphasis on the numerical value of sensitivity and threshold settings is not justified. (E 215)

transducer—an electromagnetic device for converting electrical energy into magnetic or mechanical energy and vice versa. (E 1033)

two-way sort—an electromagnetic sort based on a signal response from the material under test above or below a level established by two or more calibration standards.

wobble—in electromagnetic testing, an effect that produces variations in coil spacing (operational lift-off) due to lateral motion of the test specimen in passing through an encircling coil.

Section D: Gamma- and X-Radiology

The terms defined in Section D are the direct responsibility of Subcommittee E07.01 on Radiographic Method Radiology (X and Gamma) Method. Additional radiological terms are found in Section H.

absorbed dose—the amount of energy imparted by ionizing radiation per unit mass of irradiated matter. Denoted by “rad;” 1 rad = 0.01 j/kg. SI unit is “gray;” 1 gray = 1 j/kg.

absorbed dose rate—the absorbed dose per unit of time; rads/s. SI unit, grays/s.

absorption—the process whereby the incident particles or photons of radiation are reduced in number or energy as they pass through matter.

accelerating potential—the difference in electric potential between the cathode and anode in an X-ray tube through which a charged particle is accelerated; usually expressed in units of kV or MV.

activation—in neutron radiography, the process of causing a substance to become artificially radioactive by subjecting it to bombardment by neutrons or other particles.

acute radiation syndrome—the immediate effects of a short term, whole body overexposure of a person to ionizing radiation. These effects include nausea and vomiting, malaise, increased temperature, and blood changes.

alphanumeric—term pertaining to both numbers and alphabetical characters, typically used to designate a device capable of handling both types of characters.

alpha particle—a positively charged particle emitted by certain radio-nuclides. It consists of two protons and two neutrons, and is identical to the nucleus of a helium atom.

amorphous selenium (a-Se) radiation detector array—an array employing a biased amorphous selenium photo-conductor that directly converts incident radiation into electrical charge which can then be read to form a digital image.

amorphous silicon (α -Si) X-ray detector, *n*—an amorphous silicon (α -Si) X-ray detector consists of a glass substrate with a matrix of photodiodes fabricated from amorphous silicon and switches arranged in rows and columns upon it; the photodiodes are activated by light photons emitted from a scintillator which is activated by X rays and is usually in close contact with the diode matrix.

analog image—an image produced by a continuously variable physical process (for example, exposure of film).

analog to digital converter (a/d)—a device that changes an analog signal to a digital representation of the signal.

anode—the positive electrode of a discharge tube. In an X-ray tube, the anode carries the target.

anode current—the electrons passing from the cathode to the anode in an X-ray tube, minus the small loss incurred by the back scattered fraction.

aperture—an opening in material, space, or time over which an element is considered to be active.

area of interest—the specific portion of the object image on the radiograph that is to be evaluated.

array processor—a special purpose logical processing device that performs extremely fast mathematical operation on digital arrays.

artifact—spurious indication on a radiograph arising from, but not limited to, faulty manufacture, storage, handling, exposure, or processing.

autoradiograph—the image of an object containing a radioelement obtained, on a recording medium, by means of its own radiation.

back scattered radiation—radiation which is scattered more than 90° with respect to the incident beam, that is, backward in the general direction of the radiation source.

betatron—an electron accelerator in which acceleration is provided by a special magnetic field constraining the electrons to a circular orbit. This type of equipment usually operates at energies between 10 and 31 MEV.

blocking or masking—surrounding specimens or covering their sections with absorptive material.

blooming—in radiologic real-time imaging, an undesirable condition exhibited by some image conversion devices and television pickup tubes brought about by exceeding the allowable input brightness for the device, causing the image to go into saturation, producing a fuzzy image of degraded spatial resolution and grey scale rendition.

blow back—the enlargement of a minified radiograph to its original size by use of an optical direct reader.

cassette—a light-tight container for holding radiographic recording media during exposure, for example, film, with or without intensifying or conversion screens.

characteristic curve—the plot of density versus log of exposure or of relative exposure. (Also called the D-log E curve or the *H* and *D* curve.)

cine-radiography—the production of a series of radiographs that can be viewed rapidly in sequence, thus creating an illusion of continuity.

collimator—a device of radiation absorbent material intended for defining the direction and angular divergence of the radiation beam.

composite viewing—the viewing of two or more superimposed radiographs from a multiple film exposure.

compton scatter radiation—the scattered X-ray or gamma ray which results from the inelastic scattering of an incident X-ray or gamma ray on an electron. Since the ejected electron has short range in most materials, it is not considered part of the scattered radiation.

computed radiology (photo stimulated luminescence method)—a two-step radiological imaging process; first, a storage phosphor imaging plate is exposed to penetrating radiation; second, the luminescence from the plate's photostimulable luminescent phosphor is detected, digitized, and presented via hard copy or a CRT.

constant potential—a method of electrically generating x-rays by placing a constant potential electrical source (voltage and current) across the x-ray tube anode and cathode; the ripple component of the constant potential electrical source is typically less than 2.0 %.

contrast sensitivity—a measure of the minimum percentage change in an object which produces a perceptible density/brightness change in the radiological image.

contrast stretch—a function that operates on the greyscale values in an image to increase or decrease image contrast.

definition, image definition—the sharpness of delineation of image details in a radiograph. Generally used qualitatively.

densitometer—a device for measuring the optical density of radiograph film.

density (film)—the quantitative measure of film blackening when light is transmitted or reflected.

$$D = \log (I_0/I) \text{ or } D = \log (I_0/R) \quad (2)$$

where:

D = density,

I_0 = light intensity incident on the film,

I = light intensity transmitted, and

R = light intensity reflected.

density comparison strip—alternative term for **step-wedge comparison film**.

digital—the representation of data or physical quantities in the form of discrete codes, such as numerical characters, rather than a continuous stream.

digital image—an image composed of discrete pixels each of which is characterized by a digitally represented luminance level.

digital image acquisition system—a system of electronic components which, by either directly detecting radiation or converting analog radiation detection information, creates an image of the spatial radiation intensity map comprised of an array of discrete digital intensity values (see **pixel**).

digital image enhancement—any operation used for the purpose of enhancing some aspect of the original image.

digital image processing system—a system which uses algorithms to process digital image data.

digitize (for radiology)—the act of converting an analog image or signal to a digital presentation.

dynamic range (for radiology)—the span of signal intensity which defines the system's range of performance.

equivalent I.Q.I. sensitivity—that thickness of I.Q.I. expressed as a percentage of the section thickness radiologically examined in which a 2T hole or 2 % wire size equivalent would be visible under the same radiological conditions.

equivalent penetrometer sensitivity—that thickness of penetrometer, expressed as a percentage of the section thickness radiographed, in which a 2T hole would be visible under the same radiographic conditions.

erasable optical medium—an erasable and rewritable storage medium where the digital data is represented by the degree of reflectivity of the medium recording layer; the data can be altered.

exposure, radiographic exposure—the subjection of a recording medium to radiation for the purpose of producing a latent image. Radiographic exposure is commonly expressed in terms of milliamperere-seconds or millicurie-hours for a known source-to-film distance.

exposure table—a summary of values of radiographic exposures suitable for the different thicknesses of a specified material.

film contrast—a qualitative expression of the slope or steepness of the characteristic curve of a film; that property of a photographic material which is related to the magnitude of the density difference resulting from a given exposure difference.

film speed—a numerical value expressing the response of an image receptor to the energy of penetrating radiation under specified conditions.

filter—uniform layer of material, usually of higher atomic number than the specimen, placed between the radiation source and the film for the purpose of preferentially absorbing the softer radiations.

fluorescence—the emission of light by a substance as a result of the absorption of some other radiation of shorter wavelengths only as long as the stimulus producing it is maintained.

fluorescent screen—alternative term for **intensifying screen (b)**.

fluoroscopy—the visual observation on a fluorescent screen of the image of an object exposed to penetrating, ionizing radiation.

focal spot—for x-ray generators, that area of the anode (target) of an x-ray tube which emits x-ray when bombarded with electrons.

fog—a general term used to denote any increase in optical density of a processed photographic emulsion caused by anything other than direct action of the image forming radiation and due to one or more of the following:

- (a) *aging*— deterioration, before or after exposure, or both, resulting from a recording medium that has been stored for too long a period of time, or other improper conditions.
- (b) *base*— the minimum uniform density inherent in a processed emulsion without prior exposure.
- (c) *chemical*— resulting from unwanted reactions during chemical processing.
- (d) *dichroic*— characterized by the production of colloidal silver within the developed sensitive layer.
- (e) *exposure*— arising from any unwanted exposure of an emulsion to ionizing radiation or light at any time between manufacture and final fixing.
- (f) *oxidation*—caused by exposure to air during developing.
- (g) *photographic*—arising solely from the properties of an emulsion and the processing conditions, for example, the total effect of inherent fog and chemical fog.
- (h) *threshold*—the minimum uniform density inherent in a processed emulsion without prior exposure.

fog density—a general term used to denote any increase in the optical density of a processed film caused by anything other than the direct action of the image-forming radiation.

forward scattered radiation—radiation which is scattered less than 90° with respect to the incident beam, that is, forward in the general direction of the radiation source.

gamma-radiography—a technique of producing radiographs using gamma-rays.

gamma ray—electromagnetic penetrating radiation having its origin in the decay of a radioactive nucleus.

geometric unsharpness⁴— the penumbral shadow in a radiological image which is dependent upon 1) the radiation source dimensions, 2) the source to object distance, and 3) object to detector distance.

graininess—the visual impression of irregularity of silver deposit in a processed film.

half-life—the time required for one half of a given number of radioactive atoms to undergo decay.

half-value layer (HVL)—the thickness of an absorbing material required to reduce the intensity of a beam of incident radiation to one half of its original intensity.

half-value thickness—the thickness of a specified substance which, when introduced into the path of a given beam of radiation, reduces its intensity to one half.

image data file—a digital file containing radiological image and text information.

image definition—see **definition**.

image processing—a method whereby digital image data is transformed through a mathematical function.

image quality indicator (IQI)—in industrial radiology, a device or combination of devices whose demonstrated image or images provide visual or quantitative data, or both, to determine radiologic quality and sensitivity. Also known as a penetrameter (disparaged).

NOTE 19—It is not intended for use in judging size nor establishing acceptance limits of discontinuities.

indication, *n*—the response or evidence from a nondestructive examination that requires interpretation to determine relevance.

intensifying screen—a material that converts a part of the radiographic energy into light or electrons and that, when in contact with a recording medium during exposure, improves the quality of the radiograph, or reduces the exposure time required to produce a radiograph, or both. Three kinds of screens in common use are:

- (a) *metal screen*—a screen consisting of dense metal (usually lead) or of a dense metal compound (for example, lead oxide) that emits primary electrons when exposed to X- or gamma-rays.
- (b) *fluorescent screen*—a screen consisting of a coating of phosphors which fluoresces when exposed to X or gamma radiation.
- (c) *fluorescent-metallic screen*—a screen consisting of a metallic foil (usually lead) coated with a material that fluoresces when exposed to X or gamma radiation. The coated surface is placed next to the film to provide fluorescence; the metal functions as a normal metal screen.

IQI sensitivity—in radiography, the minimum discernible image and the designated hole in the plaque-type, or the designated wire image in the wire type image quality indicator.

keV (kilo electron volt)—a unit of energy equal to one thousand electron volts, used to express the energy of X rays, gamma rays, electrons, and neutrons.

kV (kilo volt)—a unit of electrical potential difference equal to one thousand volts, used to describe the accelerating potential of an X-ray tube.

latent image—a condition produced and persisting in the image receptor by exposure to radiation and able to be converted into a visible image by processing.

lead screen—see **intensifying screen (a)**.

line pairs per millimetre—a measure of the spatial resolution of an image conversion device. A line pair test pattern consisting of one or more pairs of equal width, high contrast lines and spaces is utilized to determine the maximum density of lines and

⁴ Mathematical designation of geometric unsharpness is provided in parentheses following the terms indicate the ASTM standards from which the terms were derived. Guide E 94.

spaces that can be successfully imaged. The value is expressed in line pairs per millimetre.

line pair test pattern—a pattern of one or more pairs of objects with high contrast lines of equal width and equal spacing. The pattern is used with an imaging device to measure spatial resolution.

linear accelerator—an electron generator in which the acceleration of the particles is connected with the propagation of a high-frequency field inside a linear or corrugated waveguide.

location marker—a number or letter made of lead (Pb) or other highly radiation attenuative material that is placed on an object to provide traceability between a specific area on the image and the part.

low-energy gamma radiation—gamma radiation having energy less than 200 keV.

luminosity—a measure of emitted light intensity.

mA (milliampere)—a unit of current equal to 0.001 amperes, used to express the tube current of an X-ray tube.

magnetic storage medium—a storage medium that uses magnetic properties (magnetic dipoles) to store digital data (for example, a moving drum, disk, or tape or a static core or film).

MeV (mega or million electron volts)—a unit of energy equal to one million electron volts, used to express the energy of X-rays, gamma rays, electrons, and neutrons.

micro focus X-ray tube—an X-ray tube having an effective focal spot size not greater than 100 μm .

milliamperes (mA)—the technical term is **tube current** and is defined as the current passing between the cathode and anode during the operation of an x-ray tube, measured in milliamperes (mA) and usually taken as a measure of x-ray intensity.

minifocus X-ray tube—an X-ray tube having an effective focal spot size between 100 and 400 μm .

MV (mega or million volt)—a unit of electrical potential difference equal to one million volts, used to describe the accelerating potential of an X-ray tube.

net density—total density less fog and support (film base) density.

neutron radiography (NRT)—a process of making an image of the internal details of an object by the selective attenuation of a neutron beam by the object.

noise—the data present in a radiological measurement which is not directly correlated with the degree of radiation attenuation by the object being examined.

non-erasable optical data—a non-erasable, non-rewriteable storage medium where the digital data is represented by the degree of reflectivity of the mediums recording layer. The data cannot be altered.

nonscreen-type film (direct-type film)—X-ray film designed for use with or without metal screens, but not intended for use with salt screens.

nuclear activity—the number of disintegrations occurring in a given quantity of material per unit of time. “Curie” is the unit of measurement. One curie is equivalent to 3.7×10^{10} disintegrations per second.

object-film distance—the distance between the surface of the source side object and the plane of the recording medium.

NOTE 20—In the case where the recording medium is placed directly in contact with the object being examined, the distance is equal to the thickness of the object.

optical density—the degree of opacity of a translucent medium (darkening of film) expressed as follows:

$$OD = \log (I_o/I) \quad (3)$$

where:

OD = optical density,

I_o = light intensity incident on the film, and

I = light intensity transmitted through the film.

optical line pair test pattern—see **line pair test pattern**.

pair production—the process whereby a gamma photon with energy greater than 1.02 MeV is converted directly into matter in the form of an electron-positron pair. Subsequent annihilation of the positron results in the production of two 0.511 MeV gamma photons.

pencil beam—a radiation beam which has little divergence, usually created by collimating an intense source of radiation.

penetrameter— alternative term for **image quality indicator**.

penetrameter sensitivity—alternative term for **IQI sensitivity**.

phosphor—any substance that can be stimulated to emit light by incident radiation.

photo fluorography—a photograph of the image formed on a fluorescent screen.

photostimulable luminescence—the physical phenomenon of phosphors absorbing incident ionizing radiation, storing the energy in quasi-stable states and emitting luminescent radiation proportional to the absorbed energy when stimulated by radiation of a different wavelength.

photostimulable luminescent phosphor—a phosphor capable of storing a latent radiological image which upon laser stimulation will generate luminescence proportional to the radiation intensity.

pixel—The smallest addressable element in an electronic image.

pixel, display size—the dimensions of the smallest picture element comprising the displayed image, given in terms of the imaged

- object's dimensions being represented by the element.
- pixel size**—the length and width of a pixel.
- primary radiation**—radiation coming directly from the source.
- radiograph**—a permanent, visible image on a recording medium produced by penetrating radiation passing through the material being tested.
- radiographic contrast**—the difference in density between an image and its immediate surroundings on a radiograph.
- radiographic equivalence factor**—that factor by which the thickness of a material must be multiplied in order to determine what thickness of a standard material (often steel) will have the same absorption.
- radiographic exposure*— see **exposure**.
- radiographic inspection**—the use of X rays or nuclear radiation, or both, to detect discontinuities in material, and to present their images on a recording medium.
- radiographic quality**—a qualitative term used to describe the capability of a radiograph to show flaws in the area under examination.
- radiographic sensitivity**—a general or qualitative term referring to the size of the smallest detail that can be seen on a radiograph, or the ease with which details can be seen.
- radiography**—the art, act, or process of making radiographs.
- radiological examination**—the use of penetrating ionizing radiation to display images for the detection of discontinuities or to help ensure integrity of the part.
- radiology**—the science and application of X rays, gamma rays, neutrons, and other penetrating radiations.
- radioscopy**—the electronic production of a radiological image that follows very closely the changes with time of the object being imaged.
- rare earth screens*— see **intensifying screen**.
- real-time radioscopy**—radioscopy that is capable of following the motion of the object without limitation of time.
- recording media**—material capable of capturing or storing, or both, a radiological image in digital or analog form.
- recording medium**—a film or detector that converts radiation into a visible image.
- representative quality indicator (RQI)**— an actual part or similar part of comparable geometry and attenuation characteristics to that of the test part(s), that has known or measurable features, or both, representing the facets of nonconformance for which the test part is to be examined.
- scintillators and scintillating crystals**— a detector that converts ionizing radiation to light.
- screen**—alternative term for intensifying screen.
- secondary radiation**—radiation emitted by any substance as the result of irradiation by the primary source.
- sensitivity**—see **contrast sensitivity, equivalent IQI sensitivity, equivalent penetrometer sensitivity, IQI sensitivity, radiographic sensitivity**.
- shim**—a material, typically placed under the IQI which is radiologically similar to the object being imaged.
- signal**—the data present in a radiological measurement which is directly correlated with the degree of radiation attenuation by the object being examined.
- source**—a machine or radioactive material that emits penetrating radiation.
- source-film distance**—the distance between the radiation-producing area of the source and the film.
- step wedge**—a device with discrete step thickness increments used to obtain an image with discrete density step values.
- step-wedge calibration film**—a step-wedge comparison film the densities of which are traceable to a nationally recognized standardizing body.
- step-wedge comparison film**—a strip of processed film carrying a stepwise array of increasing photographic density.
- step wedge comparison film**—a radiograph with discrete density steps that have been verified by comparison with a calibrated step wedge film.
- storage phosphor imaging plate**—a flexible or rigid reusable detector that stores a radiological image as a result of exposure to penetrating radiation.
- subject contrast**—the ratio (or the logarithm of the ratio) of the radiation intensities transmitted by selected portions of the specimen.
- system induced artifacts**—anomalies that are created by a system during the acquisition, display processing, or storage of a digital image.
- system noise**—the noise present in a radiological measurement resulting from the individual elements of the radiological system.
- target**—that part of the anode of an X-ray emitting tube hit by the electron beam.
- tenth-value-layer (TVL)**—the thickness of the layer of a specified substance which, when introduced into the path of a given narrow beam of radiation reduces the intensity of this radiation by a factor of ten.
- tomography**—any radiologic technique that provides an image of a selected plane in an object to the relative exclusion of structures that lie outside the plane of interest (see **tomogram** and **(CT) computed tomography**).
- total image unsharpness**—the blurring of test object features, in a radiological image resulting from any cause(s).
- translucent base media**—materials with properties that allow radiological interpretation by transmitted or reflected light.

transmission densitometer—an instrument that measures the intensity of the transmitted light through a radiographic film and provides a readout of the transmitted film density.

transmitted film density—the density of radiographic film determined by measuring the transmitted light.

tube current—the current, measured in milliamperes, passing between the cathode and anode during the operation of an X-ray tube.

tube current—the transfer of electricity, created by the flow of electrons, from the filament to the anode target in an X-ray tube; usually expressed in unit of milliamperes.

vacuum cassette—a flexible light-tight container that, when operated under a vacuum, holds film and screen in intimate contact during a radiographic exposure.

Section E: Leak Testing

The terms defined in Section E are the direct responsibility of Subcommittee E07.08 on Leak Testing Methods.

absolute manometer—a manometer whose calibration can be calculated from the measurable physical constants of the instrument and for which calibration is the same for all ideal gases.

absolute pressure—pressure above the absolute zero corresponding to empty space, that is, local atmospheric pressure plus gage pressure.

absorption—in leak testing, the binding or incorporation of gas in the interior of a solid (or liquid).

accumulation test—a leak test used to detect very small leaks in which gas contained in a component being tested will, if a leak is present, collect for a specified period of time in a closed evacuated chamber into which the component has been placed. At the end of the test period the chamber is opened to a leak detector which is sensitive to the gas.

alkali ion diode—a sensor for halogen gases. (See also **halogen leak detector** (2).)

aperture leak—a leak of such geometric configuration that the length of the leakage path is much smaller than the shortest diameter of the path, so that the leak may be considered the equivalent of an opening in an infinitesimally thin wall.

atmosphere (standard)—the pressure exerted by a mercury column 760 mm in height at 0°C under standard acceleration of gravity; equivalent to 101 325 Pa.

atmospheric pressure—the pressure of the atmosphere at a specified place and time (see Table 1).

atomic mass unit (amu)—the unit of measure of the mass of a particle (atom, molecule, ion, etc.), defined as 1/12 of the mass of carbon-12. The numerical value of the mass of a particle in terms of amu is identical with the older atomic weight.

audible leak indicator—an accessory to a leak detector which converts the output signal to an audible note whose frequency is a function of the leakage rate.

back pressure—Same as **forepressure**.

back pressure test— Same as **pressure-evacuation test**.

background signal—in leak testing, the steady or fluctuating output signal of the leak detector caused by the presence of residual tracer gas or other substance to which the detecting element responds.

backing pump—Same as **fore pump**.

backing space—the space between a backing pump (fore pump) and the associated diffusion pump (or other type of pump requiring a fore pump). (See also **ballast**.)

backing space technique—a method of testing for leaks in which the leak detector is connected to the backing space to take advantage of the compression of gas that occurs between the vacuum system and the backing pump, due to the action of the diffusion pump (or other type of pump of high speed relative to its backing pump).

bake-out—in leak testing, the degassing of a vacuum system by heating during the pumping process.

ballast—in leak testing, a backing space large enough to maintain a low forepressure when the fore pump is temporarily stopped.

Bayard-Alpert ionization gage—see **ionization vacuum gage**.

bell jar—a container, open at one end (usually the bottom), which is used as a vacuum chamber or test vessel.

TABLE 1 Composition and Partial Pressures of the Atmosphere

Constituent	Volume %	Partial Pressure, kPa
<i>At sea level (atmospheric pressure is 101 kPa):</i>		
Oxygen	21	(0.21 × 101 =) 21
Nitrogen	78	(0.78 × 101 =) 79
Others	1	(0.01 × 101 =) 1
Total atmospheric pressure, 101		
<i>At 3700-m altitude (atmosphere pressure is 64 kPa):</i>		
Oxygen	21	(0.21 × 64 =) 13
Nitrogen	78	(0.78 × 64 =) 50
Others	1	(0.01 × 64 =) 1
Total atmospheric pressure, 64		

bell jar testing—a test used for detecting leakage from an object completely or partially filled with a tracer gas and placed in a vacuum chamber or bell jar.

bomb test—see **pressure-evacuation test**.

bubble immersion test—a form of leak test of gas-containing enclosures in which a leak is indicated by the formation of a bubble at the site of a leak.

clean-up—in leak testing, the time required for a leak testing system to reduce its signal output to 37 % of the signal indicated at the time the tracer gas ceases to enter the leak system. Also called clean-up time.

clusec—an obsolete unit of flow rate equal to 10⁻² lusecs.

cold-cathode ionization gage—see **ionization vacuum gage**.

concentration ratio—in leak testing, the ratio of the number of atoms (molecules) of a given constituent of a (gas) mixture to the total number of atoms (molecules) in the mixture. For ideal gases the concentration ratio has the same value as the volume fraction or the partial pressure of the constituent.

conductance—in leak testing, the ratio of the throughput (under steady state, conservative conditions) of a gas flowing through a conduit or an orifice to the difference in the partial pressures of the gas at the two ends of the conduit or on the two sides of the orifice, expressed in volume units per unit time, such as cubic metres per second.

cracking—in leak testing, same as **dissociation**.

differential leak detector—a leak detector employing two similar gage tubes in a bridge circuit with a trap which is selective for the tracer gas between the system and one of the tubes.

differential Pirani gage—a leak detecting device employing two similar Pirani tubes as arms of a Wheatstone bridge.

diffusion—in leak testing, the flow of the gas through a substance in which the gas actually migrates through the crystal lattice of the substance rather than through a geometrical leak (molecular diameters versus hole dimension).

discharge pressure—in leak testing, same as **forepressure**.

discharge tube leak indicator—a glass tube attached to a system being leak tested, with the glass tube having electrodes attached to a source of high-frequency high voltage, such as a Tesla coil or induction coil, so that changes in the color of the electrical discharge can be observed when a suitable tracer gas (methane, carbon dioxide, alcohol) flows through the leak.

dissociation—in leak testing, the breakdown of a substance into two or more constituents.

NOTE 21—Dissociation is sometimes referred to as cracking.

drift—in leak testing, the relatively slow change in the background output level of the leak detector due to the electronics rather than a change in the level of the tracer gas.

dynamic leak test—a form of leak test in which some of the tracer gas entering through a leak is continually removed for sensing purposes.

dynamic leakage measurement—leakage determined by measuring the tracer gas equilibrium partial pressure while the system is actively being pumped.

dynamic sensitivity of leak detector—the minimum leak rate that the detector is capable of detecting while the enclosure under test is actively being evacuated continuously under specified conditions.

equivalent nitrogen pressure—the calculated pressure that a gage or another device would indicate if the gas in the device were replaced by nitrogen at the same molecular density.

exhaust pressure—in leak testing, same as **forepressure**.

exhaust tubulation—Same as **pump-out tubulation**.

flooded system—a system which, while being tested, becomes so filled with tracer gas as to make impracticable further leak testing.

flow—Same as **flow rate**.

flow rate—in leak testing, (1) the rate at which gas passes a given cross section of a system, determined by the product of the volume passing per unit time and its (partial) pressure at the cross section; (2) a product of the (partial) pressure difference of a gas at the ends of a conduit or across the face of an orifice, and the conductance of the gas for the conduit or orifice. Expressed in pressure-volume per unit time, such as pascal cubic metres per second.

fore-line—in leak testing, the line between a fore pump and the pump it backs.

fore-line valve—in leak testing, a vacuum valve placed in the fore-line to permit isolation of the diffusion pump from its backing pump.

forepressure—in leak testing, the total pressure on the outlet side of a pump measured near the outlet port. Sometimes called the back pressure, backing pressure, outlet pressure, exhaust pressure, or discharge pressure. In discussing the action of a vapor jet, the term forepressure may be used to designate the total pressure of the gas against which the jet impinges.

fore pump—in leak testing, the pump that produces the necessary fore vacuum for a pump which is incapable of discharging gases at atmospheric pressure. Sometimes called the backing pump.

gage pressure—difference between the absolute pressure and atmospheric pressure.

gas—the state of matter in which the molecules are practically unrestricted by intermolecular forces so that the molecules are free to occupy all space within an enclosure. In vacuum technology, the word gas has been loosely applied to the uncondensed gas and vapor within a vacuum system.

halogen—any element of the family of the elements fluorine, chlorine, bromine, and iodine. Compounds do not fall under the strict definition of halogen. However, for the purpose of this standard, this word provides a convenient descriptive term for halogen-containing compounds. Of significance in halogen leak detection are those which have enough vapor pressure to be useful as tracer gases.

halogen leak detector—a leak detector that responds to halogen tracer gases. Also called halogen-sensitive leak detector or halide leak detector. (1) The copper-flame detector or halide torch consists of a bunsen burner with flame impinging on a copper plate or screen, and a hose with sampling probe to carry tracer gas to the air intake of the burner. (2) The alkali-ion diode halogen detector depends on the variation of positive ion emission from a heated platinum anode when halogen molecules enter the sensing element.

helium bombing—a pressure-evacuation test in which helium is used as the test gas.

helium drift—(1) in leak testing with a probe, the drift from a leak or permeable gasket located at some distance from the end of the probe but which is detected by the probe and can mislead the operator into suspecting the area near the probe; (2) a gradual wandering of the output meter needle of the leak detector due to slowly changing helium concentrations (either due to a leak or outgassing) in the detector tube. Expressed in scale divisions per unit time.

helium leak detector—a leak detector using helium as the tracer gas.

hermetically tight seal—a seal which does not exhibit leakage when dynamically tested with commercially built leak detectors that are sensitive to a gas on the pressure side opposite to the side on which the leak detector is located, or which does not exhibit leakage with any form of liquid test.

high vacuum—see Table 2.

holding pump—a fore pump used to hold a vapor pump at operating conditions while a roughing pump reduces the system pressure to a point at which the valve between the vapor pump and the system can be opened without stopping the flow of vapor from the nozzles.

hood test—an overall test in which an object under vacuum test is enclosed by a hood which is filled with tracer gas so as to subject all parts of the test object to examination at one time. A form of dynamic leak test in which the entire enclosure or a large portion of its external surface is exposed to the tracer gas while the interior is connected to a leak detector with the objective of determining the existence of leakage.

hot-cathode ionization gage—see **ionization vacuum gage**.

hot-filament ionization gage—see **ionization vacuum gage**.

hydraulic pressure test— Same as **hydrostatic test**.

hydrostatic test—in leak testing, a pressure test in which the component being tested is filled completely with water or another liquid. Pressure, if required, is then applied to the liquid for the required time and the outside of the component is examined visually for leaks.

ideal gas—a gas that obeys Boyle’s law and has zero heat of free expansion (or also obeys Charles’ law). Also known as a perfect gas.

in-leakage rate—the combined leakage rate from all existing leaks in a specified evacuated vessel in pressure volume units per unit of time.

inlet—the opening, flange, connection, or coupling on a leak detector or leak testing system through which the tracer gas may enter due to a leak in an object under test.

inlet flange—see **inlet**.

inlet port—see **inlet**.

inside-out testing— see **bell jar testing**.

ion pump—an electrical device for pumping gas comprising a means for ionizing the gas and a system of electrodes at suitable potentials, and in some cases also a magnetic field, which causes the ions formed to move towards a surface on which they are absorbed or buried.

ion source—in leak testing, that part of a leak detector tube in which tracer gas is ionized preliminary to being detected.

ionization potential—the minimum energy, expressed in (electron) volts, required to remove an electron from an atom or molecule to form a positive ion.

ionization vacuum gage—a vacuum gage comprising a means of ionizing the gas molecules, electrodes to facilitate the collection of the positive ions formed, and means of indicating the magnitude of the collected ion current. Various types of ionization gages are distinguished according to the method of producing the ionization. The common types are as follows:

(a) *hot-cathode ionization gage*—the ions are produced by collisions with electrons emitted from a hot filament (or cathode)

TABLE 2 Degrees of Vacuum

Degrees of Vacuum	Approximate Pressure Range
Low	100 kPa to 3 kPa
Medium	3 kPa to 0.1 Pa
High	0.1 Pa to 0.1 mPa
Very high	0.1 mPa to 0.1 μPa
Ultra high	0.1 μPa and less

and accelerated by an electric field. Also called hot-filament ionization gage, or simply ion gage. The Bayard-Alpert ionization gage employs a tube with an electrode structure designed to minimize X-ray-induced electron emission from the ion collector.

(b) *cold-cathode ionization gage*—the ions are produced by a cold-cathode discharge, usually in the presence of a magnetic field which lengthens the path of the electrons between cathode and anode. The discharge tube is a transparent tube in which the color and form of a cold-cathode discharge (without the presence of a magnetic field) gives an indication of the pressure and the nature of the gas. The Phillips ionization gage is a cold-cathode ionization gage in which a magnetic field is directly parallel to the axis of an annular electrode (normally the anode) located between two plate electrodes perpendicular to the axis. Various modifications of the Penning gage are named after the inventors, and certain types are referred to as magnetron vacuum gages.

(c) *radioactive ionization gage*—the ions are produced by radiations (usually alpha particles) emitted from a radioactive source.

isolation test—in leak testing, a method of determining whether a leak is present in a system, or of obtaining an estimate of its magnitude, by observing the rate of rise of pressure in the evacuated system when the system is isolated from the pump. (See also **rate of rise**.)

Krypton 85—a tracer gas used to test for leakage when the radioisotope leak test method is used.

leak—a hole, or void in the wall of an enclosure, capable of passing liquid or gas from one side of the wall to the other under action of pressure or concentration differential existing across the wall, independent of the quantity of fluid flowing.

leak artifact—a device used to introduce gas into a system at a controlled rate, usually 10^{-7} mol/s or less.

leak detector—a device for detecting, locating, or measuring, or combination thereof, leakage.

leak testing—comprises procedures for detecting or locating or measuring leakage, or combinations thereof.

leakage rate—the flow rate of a liquid or gas through a leak at a given temperature as a result of a specified pressure difference across the leak. Standard conditions for gases are 25°C and 100 kPa. Leakage rates are expressed in various units such as pascal cubic metres per second or pascal litres per second (see Table 3).

low vacuum—see Table 2.

lusec—a unit of flow rate equal to 0.133 mPa·m³/s.

masking—in leak testing, the covering of a section of a test object so as to prevent tracer gas from entering leaks that may exist in the covered section.

mass number—the whole number nearest to the atomic mass expressed in either atomic mass units or as (chemical) atomic weight.

mass spectrometer (M.S.)—an instrument that is capable of separating ionized molecules of different mass to charge ratio and measuring the respective ion currents. The mass spectrometer may be used as a vacuum gage that relates an output which is proportioned to the partial pressure of a specified gas, as a leak detector sensitive to a particular tracer gas, or as an analytical instrument to determine the percentage composition of a gas mixture. Various types are distinguished by the method of separating the ions. The principal types are as follows:

(a) *Dempster (M.S.)*—The ions are first accelerated by an electric field through a slit, and are then deflected by a magnetic field through 180° so as to pass through a second slit.

(b) *Bainbridge-Jordan (M.S.)*—The ions are separated by means of a radial electrostatic field and a magnetic field deflecting the ions through 60° so arranged that the dispersion of ions in the electric field is exactly compensated by the dispersion in the magnetic field for a given velocity difference.

(c) *Bleakney (M.S.)*—The ions are separated by crossed electric and magnetic fields. Also called cross fields (M.S.).

TABLE 3 Conversion Factors for Leak Testing

To Convert from	To	Multiply Column 1 by
<i>Leakage Rate:</i>		
atm·cm ³ /s	Pa·m ³ /s	1.10×10^{-1}
micron·litres/s	Pa·m ³ /s	1.33×10^{-4}
micron·ft ³ /h	Pa·m ³ /s	1.05×10^{-4}
pascal·litres/s	Pa·m ³ /s	1.00×10^{-3}
STD·cm ³ /s	Pa·m ³ /s	1.01×10^{-1}
torr·litres/s	Pa·m ³ /s	1.33×10^{-1}
<i>Pressure:</i>		
atmosphere (std)	Pa	1.01×10^5
bar	Pa	1.00×10^5
micrometre of Hg	Pa	1.33×10^{-1}
micron	Pa	1.33×10^{-1}
millimetre of Hg	Pa	1.33×10^2
pounds·force/in. ²	Pa	6.89×10^3
torr	Pa	1.33×10^2
<i>Viscosity:</i>		
centipoise	Pa·s	1.00×10^{-3}
poise	Pa·s	1.00×10^{-1}
<i>Volume:</i>		
cm ³	m ³	1.00×10^{-4}
ft ³	m ³	2.83×10^{-2}
litre	m ³	1.00×10^{-3}

(d) *Nier (M.S.)*—A modification of the Dempster (M.S.) in which the magnetic field deflects the ions.

(e) *Time of Flight (M.S.)*—The gas is ionized by a pulse-modulated electron beam and each group of ions is accelerated toward the ion collector. Ions of different mass to charge ratios traverse their paths in different times.

(f) *Radio-Frequency (M.S.)*—The ions are accelerated into a radio-frequency analyzer in which ions of a selected mass to charge are accelerated through openings in a series of spaced plates alternately attached across a radio-frequency oscillator. The ions emerge into an electrostatic field which permits only the ions accelerated in the analyzer to reach the collector.

(g) *Omegatron (M.S.)*—The ions are accelerated by the cyclotron principle.

mass spectrometer leak detector—a mass spectrometer adjusted to respond only to the tracer gas.

mass spectrum—a record, graph, table, etc., that shows the relative number of ions of various mass that are produced when a given substance is processed in a mass spectrometer.

mean free path—the average distance that a molecule travels between successive collisions with other molecules.

medium vacuum—see Table 2.

micrometre—a unit of length equal to one millionth of a metre.

micron—a term for micrometre.

micron of mercury—a unit of pressure equal to that exerted by a column of mercury standing one micrometre high.

millimetre of mercury—a unit of pressure corresponding to a column of mercury exactly 1 mm high under standard acceleration of gravity. Sometimes called torr.

minimum detectable leakage rate—the magnitude of the smallest leakage rate that can be unambiguously detected by a given leak detector in the presence of conditions existing at time of test.

molecular flow—the flow of gas through a passage under conditions such that the mean-free path is greater than the largest dimension of a transverse section of the passage.

molecular leak—a leak of such geometric configuration that gas flow through it obeys the laws of molecular flow (Knudsen's law). The flow is proportional to the difference of the end pressures and inversely proportional to the square root of the molecular weight of the gas.

newton (N)—the SI unit of force ($\text{kg}\cdot\text{m}/\text{s}^2$).

noncondensable gas—a gas whose temperature is above its critical temperature, so that it cannot be liquefied by increase of pressure alone.

occlusion—the trapping of undissolved gas in a solid during solidification.

outgassing—the evolution of gas from a material in a vacuum.

outlet pressure—see **forepressure**.

palladium barrier leak detector—a leak detector using hydrogen as the tracer gas and using the principle of hydrogen diffusing through a hot palladium barrier into an evacuated vacuum gage.

partial pressure—the pressure caused by a gas, either by itself, or in the presence of other gases. When a second gas is not present, the partial pressure is the same as the total pressure.

pascal (Pa)—One pascal is approximately equal to 1×10^{-5} atm or, more precisely, $1 \text{ Pa} = 0.98692 \times 10^{-5}$ atm.

pascal cubic metres per second ($\text{Pa}\cdot\text{m}^3/\text{s}$)—the preferred unit of gas flow in the SI system. One $\text{Pa}\cdot\text{m}^3/\text{s}$ is approximately equal to 10 atm cm^3/s or, more precisely, $1 \text{ Pa}\cdot\text{m}^3/\text{s} = 9.8692 \text{ atm}\cdot\text{cm}^3/\text{s}$.

Penning gage—see **ionization vacuum gage**.

perfect gas—see **ideal gas**.

permeability coefficient—the steady-state rate of flow of gas through unit area and thickness of a solid barrier per unit pressure differential at a given temperature.

Phillips ionization gage—see **ionization vacuum gage**.

Pirani gage—see **thermal conductivity vacuum gage**.

Poiseuille flow—the particular case of laminar viscous flow through a long pipe of circular cross section.

pressure difference—in leak testing, the difference between the pressure on the inlet side of the leak and the pressure on the exit side of the leak.

pressure dye test—(1) a form of leak test in which the item or items to be tested are filled with a liquid dye or fluorescent oil which is then pressurized for the purpose of driving the liquid through possible leakage paths with the presence of the leaks being visible when viewed from the exterior; (2) a form of leak test in which the item or items to be tested are immersed in a liquid dye or fluorescent oil which is then pressurized for the purpose of driving liquid into possible leakage paths with their presence being visible when the excess liquid has been removed from the exterior.

pressure-evacuation test—a leak test in which one or more devices are placed under gas pressure for a period of time, the objective being to accumulate enough gas in those devices that may leak to permit an indication on a leak detector sensitive to the gas when the devices are placed in an evacuated system joined to the leak detector.

pressure probe—see **probe**.

pressure testing—a method of leak testing in which the component being tested is filled completely with a gas or liquid which is then pressurized. The outside of the component is examined for the detection of any leaks.

probe—in leak testing, a tube having an opening at one end, used for directing or collecting a stream of tracer gas.

- probe gas**—in leak testing, a tracer gas which issues from an orifice so as to impinge on a restricted test area.
- probe test**—a leak test in which the tracer gas is applied by means of a probe so that the area covered by the tracer gas is localized. This enables the individual leaks to be located.
- proportioning probe**—in leak testing, a probe that can vary sample to pure air ratios between 100 % sample and 100 % pure air without substantially changing the total flow from the probe.
- pump-down time**—time of evacuation.
- pump-out tubulation**—a tube extending from an evacuated device through which gas is pumped and which is usually permanently sealed off after the device has been evacuated. Sometimes called exhaust tubulation.
- radioisotope leak test system**—a leak test system which uses a radioactive tracer gas and a detector for measuring the emission from the tracer.
- rate of rise**—in leak testing, the time rate of pressure increase at a given time in a vacuum system which is suddenly isolated from the pump by a valve. The volume and temperature of the system are held constant during the rate of rise measurement. (See **isolation test**.)
- resistance (to flow)**—the reciprocal of conductance.
- response factor**—in leak testing, the response of the halogen leak detector 0.3 MPa·m³/s of refrigerant-12 (dichlorodifluoromethane, CCl₂F₂) or less, divided by the response to the same quantity of another halogen test gas. Thus, the actual leak rate of a detected leak will be the indication of the detector multiplied by the response factor. The response of mixture of a tracer and nonhalogen gases will be the response factor of the tracer divided by the fraction of tracer gas in the test gas.
- response time**—the time required for a leak detector or leak testing system to yield a signal output equal to 63 % of the maximum signal attained when tracer gas is applied continuously to the system under test. Also called response.
- roughing**—in leak testing, the initial evacuation of a vacuum system.
- roughing line**—in leak testing, a line running from a mechanical pump to a vacuum chamber through which preliminary pumping is conducted in the rough vacuum range.
- roughing pump**—in leak testing, a vacuum pump used for the initial evacuation of a vacuum system.
- sampling probe**—in leak testing, a device used to collect tracer gas from an area of the test object and feed it to the leak detector at the reduced pressure required. Also called a sniffing probe.
- scattering**—in leak testing, dispersion or diffusion in various directions due to intermolecular or ionic collisions as applied to the effect of the residual gas in a mass spectrometer tube or an ion beam traversing the tube.
- search-gas*—Same as **tracer gas**.
- sensitivity**—in the case of a leak detector, the response of the detector to tracer gas leakage (that is, scale divisions per unit of leakage rate).
- sensitivity of leak test**—the smallest leakage rate that an instrument, method, or system is capable of detecting under specified conditions. (See **minimum detectable leakage rate**.)
- sniffing probe*—Same as **sampling probe**.
- sorption**—the taking up of gas by absorption, adsorption, chemisorption, or any combination of these processes.
- spark coil leak detector**—a high-frequency discharge coil of the Tesla type which indicates pin holes in glass vacuum systems by a spark jumping between the core of the coil and the pin hole.
- spectrometer tube**—the sensing element of a mass spectrometer leak detector.
- spray probe**—in leak testing, a device for directing a small jet of tracer gas on an object under vacuum testing.
- squealer**—Same as audible leak indicator.
- standard leak**—a device that permits a tracer gas to be introduced into a leak detector or leak testing system at a known rate to facilitate calibration of the leak detector.
- standard leakage rate**—the rate of flow of atmospheric air under conditions in which: inlet pressure is 0.1 MPa ± 5 %; outlet pressure is less than 1 kPa; temperature is 25°C ± 5°C; and dew point is less than -25°C.
- thermal conductivity vacuum gage**—a vacuum gage containing two surfaces at different temperatures between which heat can be transported by the gas molecules so that changes in the temperature (or in the heating power required to maintain constant temperature) of one of the surfaces can be correlated with the gas pressure. Various types of thermal conductivity gages are distinguished according to the method of indicating the temperature change. The common types are listed below:
- (1) *Pirani Gage*—An increase of pressure from the zero point causes a decrease in the temperature of a heated filament of material having a large temperature coefficient of resistance thus unbalancing a Wheatstone bridge circuit (or the circuit is adjusted to maintain the filament temperature constant).
 - (2) *Thermocouple Gage*—The decrease in temperature of a heated filament as the pressure rises is indicated by decreased emf in a thermocouple circuit having the junction in thermal contact with the center of the heated filament.
 - (3) *Thermistor Gage*—A form of Pirani gage employing a thermistor as the heated element.
 - (4) *Bimetallic Strip Gage*—Deflection of a bimetallic strip with changing temperature indicates the changes in pressure.
- thermocouple gage*— see **thermal conductivity vacuum gage**.
- throttling**—in leak testing, reducing the net pumping speed of a pumping system by partially closing a valve or installing a section of pipeline with low conductance.

throughput—same as **flow rate** (1).

tight—in leak testing, free from leaks according to a given specification.

torr—a unit of pressure equal to 1/760th of an atmosphere.

tracer gas—a gas which, passing through a leak, can then be detected by a specific leak detector and thus disclose the presence of a leak. Also called search gas.

tracer probe leak location— Same as **probe test**.

transition flow—in leak testing, the flow of gases under conditions intermediate between laminar viscous flow and molecular flow.

ultra-high vacuum—see Table 2.

ultrasonic leak detector—an instrument that detects ultrasonic energy produced by molecular turbulence that occurs in the transition from laminar to turbulent flow of a gas through an orifice and that converts this energy to a usable signal.

vacuum—in vacuum technology a given space filled with gas at pressures below atmospheric pressure (see Table 2).

vacuum testing—(1) a method of testing for leaks in which the object under test is evacuated and the tracer gas applied to the outside surface of the object; (2) a leak-testing procedure in which the enclosure under examination is evacuated, the tracer gas applied to the outside surface of the enclosure, and the gas detected after entering the enclosure.

vapor pressure—the pressure exerted by the vapor of a solid or liquid when in equilibrium with the solid or liquid.

very high vacuum—see Table 2.

virtual leak—(1) the semblance of a leak in a vacuum system caused by slow release of trapped gas.

(2) during a rate-of-rise test, the semblance of a leak in a vacuum system caused by slow release of sorbed or occluded gas or gases on or in the surfaces and pores of all materials in a system which has been exposed to atmospheric pressure prior to evacuation.

viscous flow—the flow of gas through a duct under conditions such that the mean free path is very small in comparison with the smallest dimension of a transverse section of the duct. This flow may be either laminar or turbulent.

viscous leak—a leak of such geometric configuration that gas flow through it is viscous in nature; that is, the flow obeys Poiseuille's Law. The flow rate is proportional to the difference of the squares of the end pressures, and inversely proportional to the gaseous viscosity.

Section F: Liquid Penetrant Examination

The terms defined in Section F are the direct responsibility of Subcommittee E07.03 on Liquid Penetrant and Magnetic Particle Methods.

angstrom unit (Å)—a unit of length which may be used to express the wavelength of electromagnetic radiation, that is, light. One angstrom unit is equal to 0.1 nanometres. (1 nm = 10⁻⁹m).

background—the surface of the test part against which the indication is viewed. It may be the natural surface of the test part or the developer coating on the surface.

black light—electromagnetic radiation in the near-ultraviolet range of wavelength. (330–390 nm) (3300–3900Å).

black light filter—a filter that transmits near-ultraviolet radiation while absorbing other wavelengths.

bleedout—the action of an entrapped liquid penetrant in surfacing from discontinuities to form indications.

blotting—the action of the developer in soaking up the penetrant from the discontinuity to accelerate bleedout.

carrier—a liquid, either aqueous or nonaqueous, in which liquid penetrant examination materials are dissolved or suspended.

clean—free of contaminants.

contaminant—any foreign substance present on the test surface or in the inspection materials which will adversely affect the performance of liquid penetrant materials.

contrast—the difference in visibility (brightness or coloration) between an indication and the background.

detergent remover—a penetrant remover that is a solution of a detergent in water.

developer—a material that is applied to the test surface to accelerate bleedout and to enhance the contrast of indications.

developer, aqueous—a suspension of developer particles in water.

developer, dry powder—a fine free-flowing powder used as supplied.

developer, liquid film—a suspension of developer particles in a vehicle which leaves a resin/polymer film on the test surface after drying.

developer, non-aqueous—developer particles suspended in a nonaqueous vehicle prior to application.

developer, soluble—a developer completely soluble in its carrier, not a suspension of powder in a liquid, which dries to an absorptive coating.

developing time—the elapsed time between the application of the developer and the examination of the part.

dragout—the carryout or loss of penetrant materials as a result of their adherence to the test pieces.

drain time—that portion of the dwell time during which the excess penetrant or emulsifier drains from the part.

drying oven—an oven used for increasing the evaporation rate of rinse water or an aqueous developer vehicle from test parts.

drying time—the time required for a cleaned, rinsed or wet developed part to dry.

dwelt time—the total time that the penetrant or emulsifier is in contact with the test surface, including the time required for application and the drain time.

electrostatic spraying—a technique for attaining a uniform coating in which the material sprayed is given an electrical charge.

eluant—a liquid used to extract one material from another, as in chromatography.

emulsification time—the time that an emulsifier is permitted to remain on the part to combine with the surface penetrant prior to removal. Also called emulsification dwell time.

emulsifier—a liquid that interacts with an oily substance to make it water-washable.

emulsifier, hydrophilic—a water-based liquid used in penetrant examination which interacts with the penetrant oil rendering it water-washable.

emulsifier, lipophilic—an oil based liquid used in penetrant examination which interacts with the penetrant oil rendering it water-washable.

etching—the removal of surface material by chemical or electrochemical methods.

family—a complete series of penetrant materials required for the performance of a liquid penetrant examination.

fluorescence—the emission of visible radiation by a substance as a result of, and only during, the absorption of black light radiation.

footcandle (fc)—the illumination on a surface, 1 ft² in area, on which is uniformly distributed a flux of 1 lm (lumen). It equals 10.8 lm/m².

hydrophilic emulsifier— see **emulsifier**.

immersion rinse—a means of removing excess penetrant in which the test parts are dipped into an agitated tank of water or remover.

immersion rinse—a means of removing surface penetrant, in which the test part is immersed in a tank of either water or remover.

inspection—visual examination of the test part after completion of the liquid penetrant processing steps.

lipophilic emulsifier— see **emulsifier lipophilic**.

liquid penetrant examination—a nondestructive test that uses suitable liquids that penetrate discontinuities open to the surface of solid materials and, after appropriate treatment, indicate the presence of discontinuities.

overemulsification—excessive emulsifier dwell time which results in the removal of penetrants from some discontinuities.

overwashing—too long or too vigorous washing, or both, which results in removal of penetrants from some discontinuities.

penetrant—a solution or suspension of dye.

penetrant comparator—an intentionally flawed specimen having separate but adjacent areas for the application of different liquid penetrant materials so that a direct comparison of their relative effectiveness can be obtained.

NOTE 22—It can also be used to evaluate liquid penetrant techniques, liquid penetrant systems, or test conditions.

penetrant, fluorescent—a penetrant that emits visible radiation when excited by black light.

penetrant, post emulsifiable—a liquid penetrant that requires the application of a separate emulsifier to render the excess surface penetrant water-washable.

penetrant, solvent-removable—a liquid penetrant so formulated that most of the excess surface penetrant can be removed by wiping with a lint-free material, with the remaining surface penetrant traces removable by further wiping with a lint-free material lightly moistened with solvent remover.

penetrant, visible—a liquid penetrant that is characterized by an intense color, usually red.

penetrant, water-washable—a liquid penetrant with a built-in emulsifier.

penetration time—same as **dwell time**.

pooling—the existence of excessive amounts of penetrant, emulsifier or developer in an incompletely drained area.

post-cleaning—the removal of residual liquid penetrant examination materials from the test part after the penetrant examination has been completed.

post emulsification—a penetrant removal technique employing a separate emulsifier.

precleaning—the removal of surface contaminants from the test part so that they will not interfere with the examination process.

rinse—the process of removing liquid penetrant examination materials from the surface of a test part by means of washing or flooding with another liquid, usually water. The process is also termed **wash**.

solvent remover—a volatile liquid penetrant used to remove excess penetrant from the surface being examined.

temperature envelope—the temperature range over which a particular penetrant inspection test will operate.

viscosity—the property of a fluid that presents a resistance to shearing flow.

visible light—electromagnetic radiation in the 400–700 (4000–7000 Å) wavelength range.

visual adaptation—the adjustment of the eyes when one passes from a bright to a darkened place.

wash—same as **rinse**.

water tolerance—the amount of water that a penetrant or emulsifier can absorb before its effectiveness is impaired.

wetting action—the ability of a liquid to spread over and adhere to solid surfaces.

Section G: Magnetic Particle Examination

The terms defined in Section G are the direct responsibility of Subcommittee E07.03 on Liquid Penetrant and Magnetic Particle Methods.

- ammeter shunt**—a low-resistance precision resistor with high current carrying capacity connected in parallel with an ammeter.
- ampere turns**—the product of the number of turns of a coil and the current in amperes flowing through the coil.
- arc strikes**—localized burn damage to a part from an arc caused by making or breaking an energized electrical circuit.
- background**—in magnetic particle examination, the appearance of the surface of the test part against which indications are viewed.
- bath*—see **suspension**.
- bipolar field*—see **field, bipolar**.
- black light**—electromagnetic radiation in the near ultraviolet range of wavelength (330 to 390 nm) (3300 to 3900 Å).
- black light filter**—a filter that transmits near ultraviolet radiation while absorbing other wavelengths.
- carrier fluid**—the fluid in which fluorescent and nonfluorescent magnetic particles are suspended to facilitate their application.
- central conductor**—a conductor passed through a hollow part and used to produce circular magnetization within the part.
- circular field*—see **field, circular**.
- circular magnetization**—the magnetization in a part resulting from current passed directly through the part or through a central conductor.
- coercive force**—the magnetizing force at which the magnetic flux density is equal to zero. The corresponding field intensity value is indicative of the ease of difficulty or demagnetization.
- coil method**—a method of magnetization in which part, or whole, of the component is encircled by a current-carrying coil.
- coil technique**—a technique of magnetization in which all, or a portion, of the part is encircled by a current-carrying coil.
- conditioning agent**—an additive to water suspensions that imparts specific properties such as: proper wetting, particle dispersion, corrosion resistance, biological resistance, or foam inhibition.
- contact head**—electrode assembly used to clamp and support a part to facilitate passage of electrical current through the part for circular magnetization.
- contact pad**—replaceable metal pad, usually of copper braid, placed on electrodes to give good electrical contact, thereby preventing damage, such as arc strikes, to the part under test.
- continuous method**—with relation to magnetic particle inspection: a method wherein the indicating medium is applied while the magnetizing force is present.
- core (of an electromagnetic inspection circuit)**—that part of the magnetic circuit which is within the electrical winding.
- Curie point**—the temperature at which ferromagnetic materials can no longer be magnetized by outside forces, and at which they lose their residual magnetism (approximately 1200 to 1600°F (649 to 871°C) for many metals).
- current flow method**—a method of magnetizing by passing a current through a component via prods or contact heads. The current may be alternating, rectified alternating, or direct.
- current induction method**—a method of magnetizing in which a circulating current is induced in a ring component by the influence of a fluctuation magnetic field that links the component.
- dark adaptation**—the adjustment of the eyes when one passes from a bright to a darkened place.
- demagnetization**—the reduction of residual magnetism to an acceptable level.
- diffuse indications**—indications that are not clearly defined as, for example, indications of subsurface defects.
- direct contact magnetization**—a technique of magnetizing in which the current is passed through a part via prods or contact heads.
- dry method**—magnetic particle inspection in which the ferromagnetic particles employed are in the dry powder form.
- dry powder**—finely divided ferromagnetic particles suitably selected and prepared for magnetic particle inspection.
- dry technique**—in magnetic particle examination, the examination technique in which the ferromagnetic particles are applied in the dry powder form.
- electromagnet**—a soft iron core surrounded by a coil of wire that temporarily becomes a magnet when an electric current flows through the wire.
- energizing cycle**—the application of a magnetizing force to a conductor.
- examination medium**—a powder or suspension of magnetic particles that is applied to a magnetized test surface to determine the presence or absence of surface or slightly subsurface discontinuities.
- ferromagnetic**—a term applied to materials that can be magnetized or strongly attracted by a magnetic field.
- field, bipolar**—longitudinal magnetic field within a part that has two poles.
- field, circular magnetic**—generally, the magnetic field surrounding any electrical conductor or part resulting from a current being passed through the part or conductor from one end to another.
- field, longitudinal magnetic**—magnetic field wherein the flux lines traverse the component in a direction essentially parallel with its longitudinal axis.
- field, magnetic**—the space, within and surrounding a magnetized part or a conductor carrying current, in which the magnetic force is exerted.

- field, magnetic leakage**—the magnetic field that leaves or enters the surface of a part at a discontinuity or change in section configuration of a magnetic circuit.
- field, residual magnetic**—the field that remains in a piece of magnetizable material after the magnetizing force has been removed.
- field, resultant magnetic**—(sometimes called vector): a magnetic field that is the result of two magnetizing forces impressed upon the same area of a magnetizable object.
- field strength*—see **magnetic field strength**.
- fill factor**—in magnetic particle examination, the ratio of the cross sectional area of the part being tested to the cross sectional area of the encircling coil.
- flash magnetization**—magnetization by a current flow of very brief duration.
- flash point**—the lowest temperature at which vapors above a volatile combustible substance ignite in air when exposed to a flame.
- fluorescence**—the emission of visible radiation by a substance as the result of, and only during, the absorption of black light radiation.
- fluorescent examination method**—the magnetic particle examination method employing a finely divided fluorescent ferromagnetic inspection medium.
- fluorescent magnetic particle inspection**—the magnetic particle inspection process employing a finely divided fluorescent ferromagnetic inspection medium that fluoresces when activated by black light (3200 to 4000 Å (320 to 400 nm)).
- flux density, magnetic**—the strength of a magnetic field, expressed in flux lines per unit area.
- flux leakage field**—the magnetic field that leaves or enters the surface of a part as the result of a discontinuity or a change in section.
- flux lines*—see **lines of force**.
- flux penetration**—the depth to which a magnetic flux exists in a part.
- full-wave direct current (FWDC)**—a rectified three-phase alternating current.
- furring**—buildup or bristling of magnetic particles due to excessive magnetization of the component under examination resulting in a furry appearance.
- gaussmeter, *n***—a device that measures magnetic flux density or magnetic induction (a quantity directly related to magnetic field strength or magnetic force); also known as a Tesla Meter or Magnetometer.
- gaussmeter (electronic), *n***—a gaussmeter that uses a hall effect probe to measure magnetic flux density.
- half-wave current (HW)**—a rectified single-phase alternating current that produces a pulsating unidirectional field.
- hall effect**—a phenomenon in which a transverse electric field is produced in a current-carrying conductor placed in a magnetic field.
- hysteresis**—(1) the lagging of the magnetic effect when the magnetic force acting upon a ferromagnetic body is changed.
(2) the phenomenon exhibited by a magnetic system wherein its state is influenced by its previous history.
- indirect magnetization**—magnetization induced in a part when no direct electrical contact is made.
- induced current method*— see **current induction method**.
- induced field*—see **indirect magnetization**.
- inherent fluorescence**—fluorescence that is an intrinsic characteristic of a material.
- inspection medium*— see **examination medium**.
- leakage field*—see **field, magnetic leakage**.
- leeches**—permanent magnets or electromagnets that are attached to the electrodes carrying magnetizing current and that are strong enough to hold electrode contact firmly.
- light intensity**—the light energy reaching a unit area of surface per unit time.
- lines of force**—a conceptual representation of magnetic flux based upon the line pattern produced when iron filings are sprinkled on paper laid over a permanent magnet.
- local magnetization**—magnetization of a prescribed volume or surface of a part.
- longitudinal magnetization**—a magnetic field wherein the lines of force traverse the part in a direction essentially parallel with its longitudinal axis.
- magnet, permanent*— see **permanent magnet**.
- magnetic field**—the volume within and surrounding either a magnetized part or a current-carrying conductor wherein a magnetic force is exerted.
- magnetic field indicator**—a pocket meter that is used to locate or determine the relative intensity of leakage field emanating from a part.
- magnetic field meter**—an instrument designed to measure the flux density of magnetic fields.
- magnetic field strength**—the measured intensity of a magnetic field at a point, expressed in oersteds or amperes per metre.
- magnetic hysteresis**—in a magnetic material, as iron, a lagging in the values of resulting magnetization due to a changing magnetic force. (See also **hysteresis**.)
- magnetic particle examination**—a nondestructive test method utilizing magnetic leakage fields and suitable indicating materials to disclose surface and near-surface discontinuity indications.
- magnetic particle examination flaw indications**—the accumulation of ferromagnetic particles along the areas of flaws or

discontinuities due to the distortion of the magnetic lines of force in those areas.

magnetic particle field indicator—an instrument, typically a bi-metal (for example, carbon steel and copper) octagonal disk, containing artificial flaws used to verify the adequacy or direction, or both, of the magnetizing field.

magnetic particles—finely divided ferromagnetic material capable of being individually magnetized and attracted to distortion in a magnetic field.

magnetic pole—one of two or more areas of flux leakage on a part.

magnetic writing—a form of nonrelevant indication sometimes caused when the surface of a magnetized part comes in contact with another piece of ferromagnetic material.

magnetization, circular— see **field, circular**.

magnetization, longitudinal—see **field, longitudinal**.

magnetizing current—the flow of either alternating or direct current used to induce magnetism into the part being inspected.

magnetizing force—the magnetizing field applied to a ferromagnetic material to induce magnetization.

multidirectional magnetization—the alternative application of magnetic fields in different directions during the same time frame.

near surface discontinuity—a discontinuity not open to, but lying near, the surface of a part undergoing examination which produces broad, fuzzy, lightly held powder patterns.

overall magnetization—magnetization of an entire part with a single energizing cycle.

permanent magnet—a magnet that retains a high degree of magnetization virtually unchanged for a long period of time (characteristic of materials with high retentivity).

permeability—the ratio of flux density produced to magnetizing force (the ease with which a material can become magnetized).

pole—the area on a magnetized part from which the magnetic field is leaving or returning into the part.

polymer technique—the examination technique in which a polymer is used as the particle suspension vehicle.

powder—see **dry powder**.

powder blower—a compressed air device used to apply magnetic powder over the surface of a part undergoing inspection.

prods—hand-held electrodes.

quick break—a sudden interruption of the magnetizing current.

reference standard, *n*—a material or object for which all relevant chemical and physical characteristics are known and measurable, used as a comparison for, or standardization of, equipment or instruments used for nondestructive testing. (Also see (See also **standardization, instrument**.)

residual magnetic field—the field that remains in ferromagnetic material after the magnetizing force has been removed.

residual technique—the application of the magnetic particles after the magnetizing force has been discontinued.

resultant field—see **field, resultant**.

retentivity—the ability of a material to retain a portion of the applied magnetic field after the magnetizing force has been removed.

saturation, magnetic—the total magnetization produced in a ferromagnetic material, at which point the incremental permeability has progressively decreased to approach unity.

sensitivity—the degree of capability of a magnetic particle examination technique for indicating surface or near surface discontinuities in ferromagnetic materials.

shot—a short energizing cycle in a magnetic particle examination.

skin effect—the phenomenon that causes the magnetization produced by alternating current to be contained near the surface of a ferromagnetic part.

solenoid—an electrical conductor formed into a coil.

subsurface discontinuity—any defect that does not open onto the surface of the part in which it exists.

surge magnetization—use of a high initial current for a short period (less than a second), then a continuous reduced current while the inspection medium is applied.

suspension—a two-phase system consisting of a finely divided solid dispersed in a liquid.

swinging field—see **multidirectional magnetization**.

test piece—a specimen containing known artificial or natural defects used for checking the efficiency of magnetic particle flaw detection processes.

test ring—a ring specimen containing artificial subsurface discontinuities which is used to evaluate and compare the overall performance and sensitivity of magnetic particle examination techniques.

through-coil technique— see **coil technique**.

true continuous technique—magnetic particle examination in which the magnetizing current is applied prior to the application of the magnetic particles and is maintained without interruption throughout the examination.

vehicle—a liquid medium for the suspension of magnetic particles.

visible light—radiant energy generated in 400 to 700 nm (4000 to 7000 Å) wavelength range.

water break test—a quality control test of conditioned water.

wet slurry technique—a magnetic particle examination technique in which the magnetic particles are suspended in a high-viscosity vehicle.

wet technique—the examination technique in which the magnetic particles are suspended in a liquid vehicle.

white light—see **visible light**.

yoke—a magnet that induces a magnetic field in the area of a part that lies between its poles. Yokes may be permanent magnets or either alternating-current or direct-current electromagnets.

yoke magnetization—a longitudinal magnetic field induced in a part, or in an area of a part, by means of an external electromagnet shaped like a yoke.

Section H: Neutron Radiology

The terms defined in Section H are the direct responsibility of Subcommittee E07.05 on the Radiology (Neutron) Method. Additional radiological terms can be found in Section D.

activation—the process of causing a substance to become artificially radioactive by subjecting it to bombardment by neutrons or other particles.

attenuation coefficient—related to the rate of change in the intensity of a beam of radiation as it passes through matter. (See **linear and mass attenuation coefficient**.)

attenuation cross section—the probability, expressed in barns, that a neutron will be totally absorbed by the atomic nucleus.

barn—a unit of area used for expressing the area of nuclear cross sections.

$$1 \text{ barn} = 10^{-24} \text{ cm}^2 \quad (4)$$

cadmium ratio—the ratio of the neutron reaction rate measured with a given bare neutron detector to the reaction rate measured with an identical neutron detector enclosed by a particular cadmium cover and exposed in the same neutron field at the same or an equivalent spatial location.

NOTE 23—In practice, meaningful experimental values can be obtained in an isotropic neutron field by using a cadmium filter approximately 1-mm thick.

cassette—a light-tight device for holding film or conversion screens and film in close contact during exposure.

contrast agent—a material added to a component to enhance details by selective absorption of the incident radiation.

conversion screen—a device that converts the imaged neutron beam to radiation or light that exposes the radiographic film.

cross section—the apparent cross-sectional area of the nucleus as calculated on the basis of the probability of occurrence of a reaction by collision with a particle. It does not necessarily coincide with the geometrical cross-sectional area πr^2 . It is given in units of area, $1 \text{ barn} = 10^{-24} \text{ cm}^2$.

direct exposure imaging—in the direct exposure imaging method, the conversion screen and image recorder are simultaneously exposed to the neutron beam.

electron volt—the kinetic energy gained by an electron after passing through a potential difference of 1 V.

facility scattered neutrons—neutrons scattered in the facility that contribute to the film exposure.

γ —effective gamma content. γ is the percent background film darkening caused by low-energy photon radiation absorbed by pair production in 2 mm of lead.

gamma ray—electromagnetic radiation having its origin in an atomic nucleus.

half-life—the time required for one half a given number of radioactive atoms to undergo decay.

half-value layer—the thickness of an absorbing material required to reduce the intensity of a beam of incident radiation to one-half of its original intensity.

image quality indicator—a device or combination of devices whose image or images on a neutron radiograph provide visual or quantitative data, or both, concerning the radiographic sensitivity of the particular neutron radiograph.

indirect exposure—a method in which only a gamma-insensitive conversion screen is exposed to the neutron beam. After exposure, the conversion screen is placed in contact with the image recorder.

L/D ratio—one measure of the resolution capability of a neutron radiographic system. It is the ratio of the distance between the entrance aperture and the image plane (L) to the diameter of the entrance aperture (D).

linear attenuation coefficient—a measure of the fractional decrease in radiation beam intensity per unit of distance traveled in the material (cm^{-1}).

low-energy photon radiation—gamma- and X-ray photon radiation having energy less than 200 keV (excluding visible and ultraviolet light).

mass attenuation coefficient—a measure of the fractional decrease in radiation beam intensity per unit of surface density $\text{cm}^2 \cdot \text{gm}^{-1}$.

moderator—a material used to slow fast neutrons. Neutrons are slowed down when they collide with atoms of light elements such as hydrogen, deuterium, beryllium, and carbon.

NC—effective thermal neutron content or neutron radiographic contrast. NC is the percent background film exposure due to unscattered thermal neutrons.

neutron—a neutral elementary particle having an atomic mass close to 1. In the free state outside of the nucleus, the neutron is unstable having a half-life of approximately 10 min.

- neutron radiography**—the process of producing a radiograph using neutrons as the penetrating radiation.
- object scattered neutrons**—neutrons scattered by the test objects that contribute to the film exposure.
- P**—effective pair production content. *P* is the percent background exposure caused by pair production in 2 mm of lead.
- pair production**—the process whereby a gamma photon with energy greater than 1.02 MeV is converted directly into matter in the form of an electron-positron pair. Subsequent annihilation of the positron results in the production of two 0.511 MeV gamma photons.
- process control radiograph**—a radiograph which images a beam purity indicator and sensitivity indicator under identical exposure and processing procedures as the test object radiograph. A process control radiograph may be used to determine image quality parameters in circumstances of large or unusual test object geometry.
- radiograph**—a permanent, visible image on a recording medium produced by penetrating radiation passing through the material being tested.
- radiographic inspection**—the use of X rays or nuclear radiation, or both, to detect discontinuities in material, and to present their images on a recording medium.
- radiography**—the process of producing a radiograph using penetrating radiation.
- radiological examination**—the use of penetrating ionizing radiation to display images for the detection of discontinuities or to help ensure integrity of the part.
- radiology**—the science and application of X rays, gamma rays, neutrons, and other penetrating radiations.
- radioscopic inspection**—the use of penetrating radiation and radioscopy to detect discontinuities in material.
- radioscopy**—the electronic production of a radiological image that follows very closely the changes with time of the object being imaged.
- real-time radioscopy**—radioscopy that is capable of following the motion of the object without limitation of time.
- S**—effective scattered neutron content. *S* is the percent background film darkening caused by scattered neutrons.
- scattered neutrons**—neutrons that have undergone a scattering collision but still contribute to film exposure.
- sensitivity value**—the value determined by the smallest standard discontinuity in any given sensitivity indicator observable in the radiographic image. Values are defined by identification of type of indicator, size of defect, and the absorber thickness on which the discontinuity is observed.
- thermalization**—the process of slowing neutron velocities by permitting the neutrons to come to thermal equilibrium with a moderating medium.
- thermalization factor**—the inverse ratio of the thermal neutron flux obtained in a moderator, per source neutron.
- thermal neutrons**—neutrons having energies ranging between 0.005 eV and 0.5 eV; neutrons of these energies are produced by slowing down fast neutrons until they are in equilibrium with the moderating medium at a temperature near 20°C.
- total cross section**—the sum of the absorption and scattering cross sections.
- vacuum cassette**—a light-tight device having a flexible entrance window, which when operated under a vacuum, holds the film and conversion screen in intimate contact during exposure.

Section I: Ultrasonic Examination (E 127, E 494, E 664, and E 804)

The terms defined in Section I are the direct responsibility of Subcommittee E07.06 on Ultrasonic Methods.

- A-scan**—a method of data presentation utilizing a horizontal base line that indicates distance, or time, and a vertical deflection from the base line which indicates amplitude.
- acoustic birefringence**—~~a property of anisotropic materials which causes shear waves—the effect observed when orthogonally polarized in SH-shear waves are propagated through the principal stress directions to propagate with different velocities same material thickness and the difference in a direction perpendicular phase velocity is related to the principal stress directions. Velocities along the principal axes components of stress are equal if the principal stresses are equal. plane stress.~~
- amplitude**—the vertical pulse height of a signal, usually base to peak, when indicated by an A-scan presentation.
- angle beam**—a term used to describe an angle of incidence or refraction other than normal to the surface of the test object, as in angle beam examination, angle beam search unit, angle beam longitudinal waves, and angle beam shear waves.
- apparent attenuation**—the observed ultrasound energy loss. In addition to the true loss, the apparent attenuation may also include losses attributable to instrumentation, specimen configuration, beam divergence, interface reflections, and measurement procedure. (E 664)
- area amplitude response curve**—a curve showing the changes in amplitude at normal incidence from planar reflectors of different areas located at equal distances from the search unit in an ultrasonic-conducting medium.
- attenuation**—a factor that describes the decrease in ultrasound intensity with distance. Normally expressed in decibel per unit length.

NOTE 24—The attenuation parameter is sometimes expressed in nepers (Np) per unit length. The value in decibels (dB) is 8.68 times the value in nepers. If the loss over a path is 1 Np, then the amplitude has fallen to 1/e of its initial value ($e = 2.7183\dots$). (E 664)

- attenuator**—a device for altering the amplitude of an ultrasonic indication in known increments, usually decibels.
- B-scan presentation**—a means of ultrasonic data presentation which displays a cross section of the specimen indicating the approximate length (as detected per scan) of reflectors and their relative positions.
- back reflection**—indication of the echo from the far boundary of the material under test.
- back surface**—the end of a reference block that is opposite the entry surface. (E 127)
- base line**—the time of flight or distance trace (horizontal) across the A-scan CRT display (for no signal condition).
- beam axis**—the acoustic centerline of a search unit's beam pattern as defined by the locus of points of maximum sound pressure in the far field, and its extension into the near field.
- beam spread**—a divergence of the ultrasonic beam as the sound travels through a medium.
- bottom echo*—see **back reflection**.
- bi-modal technique**—Ultrasonic examination method that utilizes both the longitudinal (L-wave) and shear (S-wave) modes of propagation in order to estimate or measure flaw height.
- bubbler**—a device using a liquid stream to couple an ultrasonic beam to the test piece.
- C-scan**—an ultrasonic data presentation which provides a plan view of the test object, and discontinuities therein.
- collimator**—a device for controlling the size and direction of the ultrasonic beam.
- compressional wave*— see **longitudinal wave**.
- contact testing**—a technique in which the search unit makes contact directly with the test piece through a thin layer of couplant.
- continuous wave**—a constant flow of ultrasonic waves, as opposed to pulsed.
- control echo**—reference signal from a constant reflecting surface, such as a back reflection.
- corner effect**—the reflection of an ultrasonic beam directed at normal incidence to the line of intersection of two perpendicular planes.
- couplant**—a substance used between the search unit and test surface to permit or improve transmission of ultrasonic energy.
- creeping wave**—A compression wave that travels in a solid immediately adjacent to a boundary and generates a shear mode “headwave” (q.v.) travelling away from the boundary at the critical angle.
- DISCUSSION—Some users reserve the term lateral wave for the creeping wave following a flat parallel surface and the creeping wave is used for those waves following curved surfaces.
- critical angle**—the incident angle of the ultrasonic beam beyond which a specific refracted wave no longer exists.
- cross talk**—the signal leakage (acoustic or electric) across an intended acoustic or electric barrier.
- crystal (see transducer)**—the piezoelectric element in an ultrasonic search unit. The term is used to describe single crystal piezoelectrics as well as polycrystalline piezoelectrics, such as ferroceramics.
- DAC (distance amplitude correction) (swept gain, time corrected gain, time variable gain, etc.)**—electronic change of amplification to provide equal amplitude from equal reflectors at different depths.
- damping, search unit**—limiting the duration of a signal from a search unit subject to a pulsed input by electrically or mechanically decreasing the amplitude of successive cycles.
- dB control**—a control that adjusts the amplitude of the display signal in dB units.
- dead zone**—the distance in the material from the surface of the test object to the depth at which a reflector can first be resolved under specified conditions. It is determined by the characteristics of the search unit, the ultrasonic test instrumentation, and the test object.
- decibel (dB)**—twenty times the base ten logarithm of the ratio of two ultrasonic signal amplitudes, $dB = 20 \log_{10}(\text{amplitude ratio})$.
- delayed sweep**—an A-scan or B-scan presentation in which an initial part of the time scale is not displayed.
- DGS (distance gain size-German AVG)**—distance amplitude curves permitting prediction of reflector size compared to the response from a back surface reflection.
- diffraction**—The spreading or bending of waves as they pass through an aperture or around a barrier or obstacle or other non-homogeneity in a medium, other than by reflection or refraction.
- distance amplitude compensation (electronic)**—The compensation or change in receiver amplification necessary to provide equal amplitude on the display of the ultrasonic flaw detector for reflectors of equal area which are located at different depths in the material.
- distance amplitude response curve**—a curve showing the relationship between the different distances and the amplitudes of ultrasonic response from targets of equal size in an ultrasonic response from targets of equal size in an ultrasonic transmitting medium. (E 127)
- distance linearity range**—the range of horizontal deflection in which a constant relationship exists between the incremental horizontal displacement of vertical indications on the A-scan presentation and the incremental time required for reflected waves to pass through a known length in a uniform transmission medium. (E 494)
- dual search unit**—a search unit containing two elements, one a transmitter, the other a receiver.
- dynamic range**—a measure of the capability of a test system to accept input signals of varying magnitudes, given by the ratio of the maximum to minimum input signals which at constant gain will produce distortion-free outputs having discernible changes with incremental variations in input.

NOTE 25—Dynamic range may be stated as the numerical value of the ratio; however, this is usually expressed in decibels.

NOTE 26—When the output indications can be related to the size of recognized targets, such as flat-bottomed holes, dynamic range is sometimes expressed in terms of the maximum and minimum hole sizes that can be displayed.

echo—indication of reflected energy.

echo dynamic—amplitude versus time of arrival relationship of ultrasonic signals relative to probe position.

ensonification—see **insonification**.

far field—the zone of the beam where equal reflectors give exponentially decreasing amplitudes with increasing distance.

focused beam—converging energy of the sound beam at a specified distance.

frequency (fundamental)—in resonance testing, the frequency at which the wave length is twice the thickness of the examined material.

frequency (inspection)—effective ultrasonic wave frequency of the system used to inspect the material.

frequency (pulse repetition)—the number of times per second an electro-acoustic search unit is excited by the pulse generator to produce a pulse of ultrasonic energy. This is also called pulse repetition rate.

gap scanning—short fluid column coupling technique.

gate—an electronic means of selecting a segment of the time range for monitoring or further processing.

grazing incidence—immersion inspection with the beam directed at a glancing angle to the test surface.

harmonics—those vibrations which are integral multiples of the fundamental frequency.

headwave—a wave that is generated by mode conversion when a point source is located at the boundary of an elastic half-space.

holography (acoustic)—an inspection system using the phase interface between the ultrasonic wave from an object and a reference signal to obtain an image of reflectors in the material under test.

immersion testing—an ultrasonic examination method in which the search unit and the test part are submerged (at least locally) in a fluid, usually water.

impedance (acoustic)—a mathematical quantity used in computation of reflection characteristics at boundaries; product of wave velocity and material density.

indication—that which marks or denotes the presence of a reflector.

initial pulse—the response of the ultrasonic system display to the transmitter pulse (sometimes called main bang).

insonification—the examination of a volume in a specimen with ultrasonic energy. See also **ensonification**.

interface—the boundary between two materials.

Lamb wave—a specific mode of propagation in which the two parallel boundary surfaces of the material under examination (such as a plate or the wall of a tube) establish the mode of propagation. The Lamb wave can be generated only at particular values of frequency, angle of incidence and material thickness. The velocity of the wave is dependent on the mode of propagation and the product of the material thickness and the examination frequency.

linearity (amplitude)—a measure of the proportionality of the amplitude of the signal input to the receiver, and the amplitude of the signal appearing on the display of the ultrasonic instrument or on an auxiliary display.

linearity (time or distance)—a measure of the proportionality of the signals appearing on the time or distance axis of the display and the input signals to the receiver from a calibrated time generator or from multiple echoes from a plate of material of known thickness.

longitudinal wave—those waves in which the particle motion of the material is essentially in the same direction as the wave propagation. (E 494)

loss of back reflection—an absence or significant reduction in the amplitude of the indication from the back surface of the part under examination.

markers—the electronically generated time pulses or other indicators that are used on the instrument display to measure distance or time.

mode—the type of ultrasonic wave propagating in the materials as characterized by the particle motion (for example, longitudinal, transverse, etc.).

mode conversion—phenomenon by which an ultrasonic wave that is propagating in one mode can reflect or refract at an interface to form ultrasonic wave(s) of other modes.

multiple back reflections—successive reflections from the back surface of the material under examination.

multiple reflections—successive echoes of ultrasonic energy between two surfaces.

near field—the region of the ultrasonic beam adjacent to the transducer and having complex beam profiles. Also known as the Fresnel zone.

noise—any undesired signal (electrical or acoustic) that tends to interfere with the reception, interpretation, or processing of the desired signal.

normal incidence—(also see **(see also straight beam)**)—a condition in which the axis of the ultrasonic beam is perpendicular to the entry surface of the part under examination.

penetration depth—the maximum depth in a material from which usable ultrasonic information can be obtained and measured.

plate wave—see **Lamb wave**.

probe—see **search unit**.

pulse—a short wave train of mechanical vibrations.

pulse echo method—an inspection method in which the presence and position of a reflector are indicated by the echo amplitude and time.

pulse length—a measure of the duration of a signal as expressed in time or number of cycles.

pulse repetition rate— see **frequency (pulse repetition)**.

pulse tuning—a control used on some ultrasonic examination equipment to optimize the response of the search unit and cable to the transmitter by adjusting the frequency spectrum of the transmitted pulse.

radio frequency (r-f) display—the display of an unrectified signal on the CRT or recorder.

range—the maximum sound path length that is displayed.

Rayleigh wave—an ultrasonic surface wave in which the particle motion is elliptical and the effective penetration is approximately one wavelength.

reference block—a block that is used both as a measurement scale and as a means of providing an ultrasonic reflection of known characteristics.

reflection—see **echo**.

reflector—an interface at which an ultrasonic beam encounters a change in acoustic impedance and at which at least part of the energy is reflected.

reject (suppression)—a control for minimizing or eliminating low amplitude signals (electrical or material noise) so that larger signals are emphasized.

resolution—the ability of ultrasonic equipment to give simultaneous, separate indications from discontinuities having nearly the same range and lateral position with respect to the beam axis.

resonance method—a technique in which continuous ultrasonic waves are varied in frequency to identify resonant characteristics in order to discriminate some property of a part such as thickness, stiffness, or bond integrity.

saturation—a condition in which an increase in input signal produces no increase in amplitude on the display.

saturation level—see **vertical limit**.

scanning—the movement of a search unit relative to the test piece in order to examine a volume of the material.

scanning index—the distance the search unit is moved between scan paths after each traverse of the part.

scattered energy—energy that is reflected in a random fashion by small reflectors in the path of a beam of ultrasonic waves.

scattering—the dispersion, deflection, or redirection of the energy in an ultrasonic beam caused by small reflectors in the material being examined.

Schlieren system—an optical system used for visual display of an ultrasonic beam passing through a transparent medium.

SE probe—see **dual search unit (twin probe)**.

search unit—an electro-acoustic device used to transmit or receive ultrasonic energy, or both. The device generally consists of a nameplate, connector, case, backing, piezoelectric element, wearface, or lens, or wedge.

sensitivity—a measure of the smallest ultrasonic signal which will produce a discernible indication on the display of an ultrasonic system.

shadow—a region in a body that cannot be reached by ultrasonic energy traveling in a given direction because of the geometry of the body or a discontinuity in it.

shear wave—wave motion in which the particle motion is perpendicular to the direction of propagation.

shear wave search unit (Y cut quartz search unit)—a straight beam search unit used for generating and detecting shear waves.

signal-to-noise ratio—the ratio of the amplitude of an ultrasonic indication to the amplitude of the maximum background noise.

skip distance—in angle beam examination, the distance along the test surface, from sound entry point to the point at which the sound returns to the same surface. It can be considered the top surface distance of a complete vee path of sound in the test material.

straight beam—a vibrating pulse wave train traveling normal to the test surface.

suppression—see **reject (suppression)**.

surface wave—see **Rayleigh wave**.

sweep—the uniform and repeated movement of an electron beam across the CRT.

swept gain—see **DAC**.

test surface—that surface of a part through which the ultrasonic energy enters or leaves the part.

testing, ultrasonic—a nondestructive method of examining materials by introducing ultrasonic waves into, through or onto the surface of the article being examined and determining various attributes of the material from effects on the ultrasonic waves.

through transmission technique—a test procedure in which the ultrasonic vibrations are emitted by one search unit and received by another at the opposite surface of the material examined.

time of flight—the sound path measurement of time for the transmitted, reflected or diffracted energy in a specimen.

time of flight diffraction technique (TOFD)—an ultrasonic examination procedure using a pair of probes in a pitch-catch configuration, the probes being usually arranged symmetrically on the same surface, but opposite sides of a weld. Measurement of travel times for the forward reflected or diffracted energy from a flaw or reference surface is used to determine its depth and vertical extent.

transducer—an electroacoustical device for converting electrical energy into acoustical energy and vice versa. See also **crystal**.
transverse wave—see **shear wave**.

transverse wave—wave motion in which the particle displacement at each point in a material is perpendicular to the direction of propagation. (E 494)

true attenuation—that portion of the observed ultrasound energy loss which is intrinsic to the medium through which the ultrasound propagates. True attenuation losses may be attributed to the basic mechanisms of absorption and scattering. (E 664)

ultrasonic—pertaining to mechanical vibrations having a frequency greater than approximately 20 000 Hz.

ultrasonic noise level—the large number of unresolved indications resulting from structure or possibly from numerous small discontinuities, or both. (E 127)

ultrasonic spectroscopy—analysis of the frequency spectrum of an ultrasonic wave.

vee path—the angle-beam path in materials starting at the search-unit examination surface, through the material to the reflecting surface, continuing to the examination surface in front of the search unit, and reflection back along the same path to the search unit. The path is usually shaped like the letter V.

vertical limit—the maximum readable level of vertical indications determined either by an electrical or a physical limit of an A-scan presentation.

video presentation—display of the rectified, and usually filtered, r-f signal.

water path—the distance from the transducer to the test surface in immersion or water column testing.

wave front—a continuous surface drawn through the most forward points in a wave disturbance which have the same phase.

wave train—a succession of ultrasonic waves arising from the same source, having the same characteristics, and propagating along the same path.

wedge—in ultrasonic angle-beam examination by the contact method, a device used to direct ultrasonic energy into the material at an angle.

wheel search unit—an ultrasonic device incorporating one or more piezoelectric elements mounted inside a liquid-filled flexible tire. The beam is coupled to the test surface through the rolling contact area of the tire.

wrap around—the display of misleading reflections from a previously transmitted pulse, caused by an excessively high pulse-repetition frequency.

Section J: Infrared Examination (E 1213)

The terms defined in Section J are the direct responsibility of Subcommittee E07.10 on Emerging NDT Methods.

absorptance, α — the ratio of radiant flux absorbed by a surface to that incident upon it.

apparent temperature—the temperature of an object as determined solely from the measured radiance, assuming an emissivity of unity.

background radiation—all radiation received by the infrared sensing device that was not emitted by the specified area of the surface being examined.

background, target—that portion of the background which is confined to the field of view.

blackbody—an ideal thermal radiator (emissivity = 1.0) that emits and absorbs all of the available thermal radiation at a given temperature.

blackbody equivalent temperature—the apparent temperature of an object as determined from the measured radiance and the assumption that it is an ideal blackbody with emissivity of 1.0.

differential blackbody—an apparatus for establishing two parallel isothermal planar zones of different temperatures, and with effective emissivities of 1.0. (E 1213)

emissivity, ϵ — the ratio of the radiance of a body at a given temperature to the corresponding radiance of a blackbody at the same temperature.

extended source—a source of infrared radiation whose image completely fills the field of view of a detector.

NOTE 27—The irradiance is independent of the distance from the source to the region of observation. In practice, sources that are not extended sources are considered to be point sources; see **point source**.

field of view (FOV)—the shape and angular dimensions of the cone or the pyramid which define the object space imaged by the system; for example, rectangular, 4° wide by 3° high.

imaging line scanner—an apparatus that scans in a single dimension and is moved perpendicular to the scan direction to produce a two-dimensional thermogram of a scene.

infrared imaging system—an apparatus that converts the two-dimensional spatial variations in infrared radiance from any object surface into a two-dimensional thermogram of the same scene, in which variations in radiance are displayed in gradations of gray tone or in color.

infrared reflector—a material with a reflectance in the infrared region as close as possible to 1.00.

infrared sensing device—one of a wide class of instruments used to display or record, or both information related to the thermal

radiation received from any object surfaces viewed by the instrument. The instrument varies in complexity from spot radiometers to two-dimensional real-time imaging systems.

infrared thermographer—the person qualified or trained to use infrared imaging radiometer.

infrared thermography— see **thermography, infrared**.

instantaneous field of view (IFOV)—for a scanning system, the angular dimensions in object space within which objects are imaged by an individual detector (unit = deg or rad).

NOTE 28—The IFOV is equivalent to the horizontal and vertical fields of view of the individual detector. For small detectors, the detector angular subtenses or projections, α and β , are defined by $\alpha = a/f$ and $\beta = b/f$ where a and b are the horizontal and vertical dimensions of the detector and f is the effective focal length of the optic. (IFOV may also be expressed as a solid angle in units of sr.)

irradiance, E—the radiant flux (power) per unit area incident on a given surface (unit = W/m^2).

limiting resolution—the highest spatial frequency of a target that an imaging sensor is able to resolve.

line scanner—an apparatus that scans along a single line of a scene to provide a one-dimensional thermal profile of the scene.

minimum detectable temperature difference (MDTD)—a measure of the compound ability of an infrared imaging system and an observer to detect a target of unknown location at one temperature against a large uniform background at another temperature when displayed on a monitor for a limited time.

NOTE 29—For a given target size, the MDTD is the minimum temperature difference between the target and its background at which the observer can detect the target. The standard target is a circle whose size is given by its angular subtense, and both target and background are isothermal blackbodies.

minimum resolvable temperature difference (MRTD)—a measure of the ability of an infrared imaging system and the human observer to recognize periodic bar targets on a display. The MRTD is the minimum temperature difference between a standard periodic test pattern (7:1 aspect ratio, 4 bars) and its blackbody background at which an observer can resolve the pattern as a four-bar pattern (see Fig. 4).

modulation transfer function (MTF)—in infrared imaging systems, the modulus of a Fourier transform that describes the spatial distribution of the overall attenuation in amplitude of a thermal imaging system.

NOTE 30—MTF is a sensitive function of spatial frequency.

noise equivalent temperature difference (NETD)—the target-to-background temperature difference between a blackbody target and its blackbody background at which the signal-to-noise ratio of a thermal imaging system or scanner is unity.

object plane resolution—the dimension in the object plane that corresponds to the product of a system’s instantaneous field-of-view and a specified distance from the system to the object.

point source—a source whose linear dimensions are very small compared with the distance from the source to the region of observation.

NOTE 31—The irradiance varies inversely with the square of the distance; a unique property of point sources.

radiance, L—the flux per unit projected area per unit solid angle leaving a source or, in general, any reference surface. If $d^2\Phi$ is the flux emitted into a solid angle $d\omega$ by a source element of projected area $dA \cos \theta$, the radiance is defined as:

$$L = \frac{d^2\Phi}{d\omega \cdot dA \cos \theta} \tag{5}$$

where, as shown in Fig. 5, θ is the angle between the outward surface normal of the area element dA and the direction of observation (unit = $W/sr \cdot m^2$).

radiant exitance, M—the radiant flux per unit area leaving a surface that is,

$$M = \frac{d\Phi}{dA} \tag{6}$$

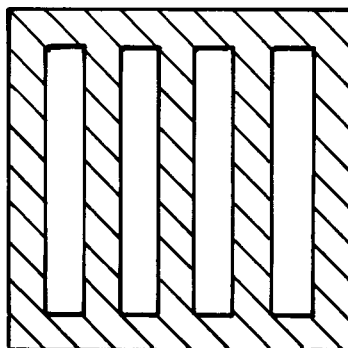

FIG. 4 Schematic Diagram of Four-Bar Pattern with Background, Used to Evaluate Minimum Resolvable Temperature Difference

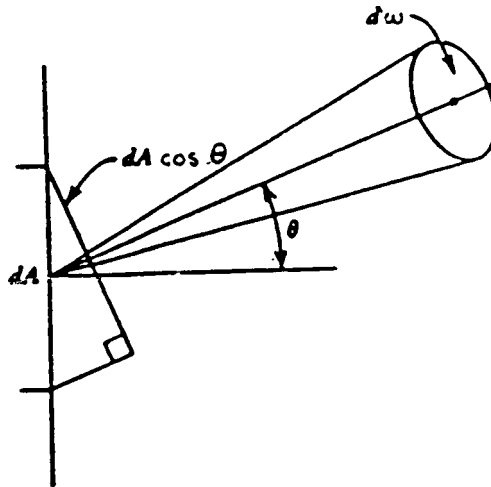

FIG. 5 Schematic Representation of Radiance

where:

$d\Phi$ = flux leaving a surface element dA (unit = W/m^2).

NOTE 32—In general, exitance includes emitted, transmitted and reflected flux.

radiant flux; radiant power, Φ_e —radiant energy per unit time (unit = W).

radiometer—an instrument for measuring the intensity of radiant energy. In infrared thermography, an apparatus that measures the average apparent temperature of the surface subtended by its field of view.

reflectance—the ratio of the radiant flux reflected from a surface to that incident upon it.

reflected temperature—the temperature of the energy incident upon and reflected from the measurement surface of a specimen.

spatial frequency—a measure of detail in terms of equivalent, uniformly spaced, cyclical patterns. In an object or image plane, it may be expressed in units of cycles per millimetre (cy/mm) or line pairs per millimetre (lp/mm). In an imaging system, it may be expressed in units of cycles per milliradian (cy/mrad) or line pairs per milliradian (lp/mrad).

thermal resolution—the smallest apparent temperature difference between two blackbodies that can be measured by an infrared sensing device.

thermogram—a visual image which maps the apparent temperature pattern of an object or scene into a corresponding contrast or color pattern.

thermography, infrared—the process of displaying variations of apparent temperature (variations of temperature or emissivity, or both) over the surface of an object or a scene by measuring variations in infrared radiance.

NOTE 33—In general, *passive thermography* refers to examination of an object or system during its normal operational mode, without the application of any additional energy source for the express purpose of generating a thermal gradient in the object or system; *active thermography* refers to the examination of an object upon intentional application of an external energy source. The energy source (active or passive) may be a source of heat, mechanical energy (vibration or fatigue testing), electrical current, or any other form of energy.

transmittance, τ —the ratio of the radiant flux transmitted through a body to that incident upon it.

vibrothermography—a thermographic technique for examining an object in which temperature differences are produced by excitation.

Section K: Optical Holography

The terms defined in Section K are the direct responsibility of Subcommittee E07.10 on Emerging NDT Methods.

- amplitude hologram**—a recording of the variation of light intensity caused by the interference between the reference beam and the object beam, as light or dark areas on the recording medium. The light and dark interference lines in the recording medium diffract laser light to produce the reconstruction.
- beam ratio**—the measured intensity of the reference beam divided by the measured intensity of the object beam in the plane of the recording medium.
- beamsplitter**—an optical device for dividing a beam into two or more separate beams.
- coherence**—a property of a beam of electromagnetic radiation in which the phase relationship between any two points across the beam or in time remains essentially constant (see **coherence length**).
- coherence length**—the path difference between the object beam and the reference beam at which interference fringes reduce in contrast by a factor of $\sqrt{2}/2$ (0.707) from the point of maximum contrast. The coherence length is related to the width of the spectral line emitted from the laser: $L_c = c/\Delta\nu$, where c is the speed of light and $\Delta\nu$ is the bandwidth of the spectral emission line.
- exposure**—the product of irradiance and time required to produce a suitable pattern on the recording medium.
- fringe, n** —one of the light or dark bands produced by the interference of the light scattered by the real object and the virtual image of the object.
- holography (optical)**—a technique for recording, and reconstructing, the amplitude and phase distributions of a wave disturbance; widely used as a method of three-dimensional optical image formation. The technique is accomplished by recording the pattern of interference between coherent light reflected from the object of interest (object beam), and light that comes directly from the same source (reference beam).
- interference**—the variation with distance or time of the amplitude of a wave which results from the superposition of two or more waves having the same, or nearly the same frequency.
- monochromatic**—a property of a beam of electromagnetic radiation in which all waves in the beam have the same wavelength.
- object beam**—the portion of laser radiation which illuminates the test object surface, is scattered, and carries object information to the recording medium.
- object beam angle**—the angle between a line from the center of the object to the center of the recording medium and the normal to the center of the recording medium.
- path length**—the distance traveled by the laser radiation from the beam splitter to the recording medium.
- path length difference**—the difference in path length between the object beam and the reference beam.
- phase hologram, n** —a recording of the variations in light intensity caused by the interference of the reference beam with the object beam as variations in the thickness or index of refraction of the recording medium. The variations in thickness or index refract coherent light to produce the reconstruction.
- real image**—a reproduction of an object by an optical system which gathers light from an object point and transforms it into a beam that converges toward another point.
- recording medium**—a light-sensitive material which detects the interference between the object beam and the reference beam. Typical recording media used in holography are silver halide film, thermoplastic film and electronic detectors, such as video tubes and CCD arrays.
- reference beam**—laser radiation impinging directly upon the recording medium through optical components and which typically does not contain information about the test object. In some tests, the reference beam may be reflected or scattered from a portion of the object surface. In this case, any object information contained in the reference beam is cancelled in the object beam by the interference between the object beam and the reference beam.
- reference beam angle**—the angle formed between the center line of the reference beam and the normal to the recording medium.
- speckle**—the random interference pattern which results from the illumination of an optically rough surface with coherent radiation. In laser systems, it results in the granular effect which can be seen in a scattered beam.
- virtual image**—a reproduction of an object by an optical system which gathers light from an object point and transforms it into a beam that appears to diverge from another point.

Section L: Visual and Optical Methods

The terms defined in Section L are the direct responsibility of Subcommittee E07.10 on Emerging NDT Methods.

- accommodation, visual**—adjustment of the eye, either the focus or the iris opening, to optimize its performance under the specific viewing conditions prevailing.
- ambient light**—light not provided by the visual testing system.
- borescope**—A flexible or rigid tube-like instrument used for a remote direct viewing visual aid. The instrument may consist of mirrors, prisms, lenses, optic-fibers, or a miniature CCD camera to transmit images to the viewing or recording medium.
- candela**—a unit of luminous intensity (formerly candle). One candela is the luminous intensity in the perpendicular direction of a surface of $1/600\,000\text{ m}^2$ of a blackbody radiator at the temperature of freezing platinum under a pressure of 101 325 Pa. One candela produces 1 lumen of luminous flux per steradian of a solid angle measured from the source.
- charge-coupled device (CCD), *n***— a light-detecting video device in which individual components are connected so that the electrical charge or signal at the output of one component provides the input to the next.
- closure**—process by which a person cognitively completes patterns or shapes that are incompletely perceived.
- contrast**—the difference between the amount of light reflected or transmitted by an object and by the background within the field of view.
- depth of field**—the range of distance over which an imaging system gives satisfactory definition when it is in the best focus for a specific distance.
- direct viewing**—a view that is not redefined by optical or electronic means.
- feature extraction**—characterization of objects in an image, usually with the goal of distinguishing those objects.
- fiber optics**—method by which light is transmitted through thin transparent fibers.
- field angle**—the included angle between those points on opposite sides of a light beam at which the luminous intensity is 10 % of the maximum value.
- filter**—a processing component or function that excludes, passes or amplifies a selected kind of signal or part of a signal.
- filter coefficients**—values which define a mask filter in image processing.
- glare**—excessive brightness which interferes with clear vision, critical observation, and judgment.
- glossmeter**—an instrument for measuring the ratio of the light regularly or specularly reflected from a surface to the total light reflected.
- illuminance**—the density of luminous flux on a surface per unit area. Measured in the SI system by lux.
- light**—electromagnetic radiation in the spectral range detectable by the normal human eye (wavelengths of approximately 380 to 780 nm).
- lumen**—luminous flux emitted within one steradian by a point source having a spatially uniform luminous intensity of one candela. SI unit of luminous flux.
- luminance**—the ratio of the luminous intensity of a surface in a given direction to a unit of projected area. Measured in candela per square metre.
- monochromator**—a device for isolating monochromatic radiation from a beam of radiation which includes a broad range of wavelengths.
- reflection**—the process by which the incident flux leaves a surface or medium from incident side, without a change in frequency, but may change polarity. Reflection is usually a combination of specular and diffuse reflection.
- saturation**—relative or comparative color characteristic resulting from a hue's dilution with white light.
- visibility**—the quality or state of being perceived by the eye. In many outdoor applications, visibility is defined in terms of the distance at which an object can be reliably resolved from its surroundings. In outdoor applications it usually is defined in terms of contrast or size of a standard test object, observed under standardized viewing conditions, having the same threshold as the given object.
- visual field**—point or points in space that can be perceived when the head and eyes are kept fixed. The field may be monocular or binocular.
- white light**—light containing all wave lengths in the visible spectrum (in the range from 380 to 780 nm).

APPENDIX

(Nonmandatory Information)

X1. TERMS DEFINED IN THIS STANDARD

X1.1 The following is an alphabetized list of terms defined in this standard:

NOTE X1.1—Section A begins on page 2; Section B begins on page 3; Section C begins on page 7; Section D begins on page 10; Section E begins on page 15; Section F begins on page 20; Section G begins on page 21; Section H begins on page 24; Section I begins on page 25; Section J begins on page 29; Section K begins on page 31; Section L begins on page 32.

	(Section)
A-scan	(I)
absolute coil	(C)
absolute manometer	(E)
absolute measurements	(C)
absolute pressure	(E)
absolute readout	(C)
absolute system	(C)
absorbed dose	(D)
absorbed dose rate	(D)
absorptance, α	(J)
absorption	(D), (E)
accelerating potential	(D)
acceptable quality level	(A)
acceptance level	(C)
acceptance limits	(C)
acceptance standard	(C)
accommodation, visual	(L)
accumulation test	(E)
<u>acoustic birefringence</u>	(I)
acoustic emission (AE)	(B)
acoustic emission channel	(B)
acoustic emission count (emission count) (N)	(B)
acoustic emission count rate (emission rate or count rate) (N)	(B)
acoustic emission event (emission event)	(B)
acoustic emission event energy	(B)
acoustic emission sensor	(B)
acoustic emission signal amplitude	(B)
acoustic emission signal (emission signal)	(B)
acoustic emission signal generator	(B)
acoustic emission signature (signature)	(B)
acoustic emission transducer	(B)
acoustic emission waveguide	(B)
acousto-ultrasonics (AU)	(B)
activation	(D), (H)
acute radiation syndrome	(D)
adaptive location	(B)
AE activity	(B)
AE amplitude	(B)
AE rms	(B)
AE signal duration	(B)
AE signal end	(B)
AE signal generator	(B)
AE signal risetime	(B)
AE signal start	(B)
alkali ion diode	(E)
alphanumeric	(D)
alpha particle	(D)
ambient light	(L)
ammeter shunt	(G)
amorphous selenium (α -Se) radiation detector array	(D)
amorphous silicon (α -Si) X-ray detector	(D)
ampere turns	(G)
amplitude	(I)
amplitude distortion	(C)
amplitude hologram	(K)
amplitude response	(C)
analog image	(D)
analog to digital converter (a/d)	(D)
angle beam	(I)
angstrom unit (A)	(F)
annular coil clearance	(C)
annular coils	(C)
anode	(D)

anode current	(D)
aperture	(D)
aperture leak	(E)
apparent attenuation	(I)
apparent temperature	(J)
arc strikes	(G)
area amplitude response curve	(I)
area of interest	(D)
array	(B)
array processor	(D)
arrival time interval (Δ_{ij})	(B)
artifact	(D)
artificial discontinuity	(C)
atmosphere (standard)	(E)
atmospheric pressure	(E)
atomic mass unit (amu)	(E)
attenuation	(B), (I)
attenuation coefficient	(H)
attenuation cross section	(H)
attenuator	(I)
audible leak indicator	(E)
autoradiograph	(D)
average signal level	(B)
B-scan presentation	(I)
back pressure	(E)
back pressure test	(E)
back reflection	(I)
back scattered radiation	(D)
back surface	(I)
background	(F), (G)
background radiation	(J)
background signal	(E)
background target	(J)
backing pump	(E)
backing space	(E)
backing space technique	(E)
bake-out	(E)
ballast	(E)
band pass filter	(C)
barn	(H)
base line	(I)
bath	(G)
Bayard-Alpert ionization gage	(E)
beam axis	(H), (I)
beam ratio	(K)
beam splitter	(K)
beam spread	(H), (I)
bell jar	(E)
bell jar testing	(E)
betatron	(D)
bipolar field	(G)
blackbody	(J)
blackbody equivalent temperature	(J)
black light	(F), (G)
black light filter	(F), (G)
bleedout	(F)
blocking or masking	(D)
blooming	(D)
blotting	(F)
blow back	(D)
bobbin coil	(C)
bomb test	(E)
borescope	(L)
bottom echo	(I)
bubble immersion test	(E)
bubbler	(I)
bucking coils	(C)
burst emission	(B)
C-scan	(I)
cadmium ratio	(H)
calibration, instrument	(A)
candela	(L)
carrier	(F)
carrier fluid	(G)
cassette	(D), (H)
central conductor	(G)
channel, acoustic emission	(B)
characteristic curve	(D)

Charge–Coupled Device (CCD)	(L)
cine-radiography	(D)
circular field	(G)
circular magnetization	(G)
circumferential coils	(C)
clean	(F)
clean-up	(E)
closure	(L)
clusec	(E)
coercive force	(G)
<u>cognizant engineering organization</u>	(A)
coherence	(K)
coherence length	(K)
coil, absolute	(C)
coil method	(G)
coil, reference	(C)
coil size	(C)
coil spacing	(C)
coil technique	(G)
coil, test	(C)
cold-cathode ionization gage	(E)
collimator	(D), (I)
comparative measurements	(C)
comparative readout	(C)
comparative system	(C)
comparator coils	(C)
composite viewing	(D)
compressional wave	(I)
compton scatter radiation	(D)
computed location	(B)
computed radiology (psl method)	(D)
concentration ratio	(E)
conditioning agent	(G)
conductance	(E)
conductivity	(C)
constant potential	(D)
contact head	(G)
contact pad	(G)
contact testing	(I)
contaminant	(F)
continuous emission	(B)
continuous method	(G)
continuous wave	(I)
contrast	(F), (L)
contrast agent	(H)
contrast sensitivity	(D)
contrast stretch	(D)
control echo	(I)
conversion screen	(H)
core (of an electromagnetic inspection circuit)	(G)
corner effect	(I)
count, acoustic emission (emission count) (N)	(B)
count, event (Ne)	(B)
count rate, acoustic emission (emission rate or count rate) (N)	(B)
count, ring-down	(B)
couplant	(B), (I)
coupling	(C)
cracking	(E)
critical angle	(I)
cross section	(H)
cross talk	(I)
crystal (see transducer)	(I)
cumulative (acoustic emission) amplitude distribution F(V)	(B)
cumulative (acoustic emission) threshold crossing distribution Ft(V)	(B)
Curie point	(G)
current flow method	(G)
current induction method	(G)
cut-off level	(C)
DAC	(I)
damping, search unit	(I)
dark adaptation	(G)
dB _A E	(B)
dB control	(I)
dead time, instrumentation	(B)
dead zone	(I)
decibel (dB)	(I)
defect	(A)

defect resolution	(C)
definition, image definition	(D)
delayed sweep	(I)
demagnetization	(G)
densitometer	(D)
density (film)	(D)
density comparison strip	(D)
depth of field	(L)
depth of penetration	(C)
detergent remover	(F)
developer	(F)
developer, dry powder	(F)
developer, liquid film	(F)
developer, non-aqueous	(F)
developer, soluble	(F)
developer, wet (aqueous suspendible)	(F)
developing time	(F)
DGS (distance gain size-German AVG)	(I)
diamagnetic material	(C)
differential (acoustic emission) amplitude distribution F(v)	(B)
differential (acoustic emission) threshold crossing distribution ft(V)	(B)
differential blackbody	(J)
differential coils	(C)
differential leak detector	(E)
differential measurements	(C)
differential Pirani gage	(E)
differential readout	(C)
differential signal	(C)
differential system	(C)
diffuse indications	(G)
diffusion	(E)
digital	(D)
digital image	(D)
digital image acquisition system	(D)
digital image enhancement	(D)
digital image processing system	(D)
digitize (for radiology)	(D)
direct contact magnetization	(G)
direct exposure imaging	(H)
direct viewing	(L)
discharge pressure	(E)
discharge tube leak indicator	(E)
discontinuity	(A)
dissociation	(E)
distance amplitude compensation	(I)
distance-amplitude response curve	(I)
distance linearity range	(I)
distribution, amplitude, cumulative (acoustic emission) F(V)	(B)
distribution, differential (acoustic emission) amplitude f(V)	(B)
distribution, differential (acoustic emission) threshold crossing ft(V)	(B)
distribution, logarithmic (acoustic emission) amplitude g(V)	(B)
distribution, threshold crossing, cumulative (acoustic emission) Ft(V)	(B)
dragout	(F)
drain time	(F)
drift	(E)
dry method	(G)
dry powder	(G)
dry technique	(G)
drying oven	(F)
drying time	(F)
dual search unit	(I)
dwel time	(F)
dynamic leak test	(E)
dynamic leakage measurement	(E)
dynamic range	(B), (I)
dynamic range (for radiology)	(D)
dynamic sensitivity of leak detector	(E)
echo	(I)
<u>echo dynamic</u>	(I)
eddy current	(C)
eddy current testing	(C)
edge effect	(C)
effective depth penetration (EDP)	(C)
effective permeability	(C)
effective velocity	(B)

electrical center	(C)
electromagnet	(G)
electromagnetic testing	(C)
electron volt	(H)
electrostatic spraying	(F)
eluant	(F)
emission, burst	(B)
emission, continuous	(B)
emissivity, ϵ	(J)
emulsification time	(F)
emulsifier	(F)
emulsifier, hydrophilic	(F)
emulsifier, lipophilic	(F)
encircling coils	(C)
end effect	(C)
energizing cycle	(G)
energy, acoustic emission event	(B)
energy, acoustic emission signal	(B)
ensonification	(I)
equivalent I.Q.I sensitivity	(D)
equivalent nitrogen pressure	(E)
equivalent penetrometer sensitivity	(D)
erasable optical medium	(D)
etching	(F)
evaluation	(A)
evaluation threshold	(B)
event acoustic emission event	(B)
event count (Ne)	(B)
event count rate (Ne)	(B)
examination	(A)
examination area	(B)
examination medium	(G)
examination region	(B)
exhaust pressure	(E)
exhaust tubulation	(E)
exposure	(K)
exposure, radiographic exposure	(D)
exposure table	(D)
extended source	(J)
facility scattered neutrons	(H)
false indication	(A)
family	(F)
far field	(I)
Feature Extraction	(L)
feed-through coils	(C)
Felicity effect	(B)
Felicity ratio	(B)
ferromagnetic	(G)
ferromagnetic material	(C)
fiber optics	(L)
field angle	(L)
field, bipolar	(G)
field, circular magnetic	(G)
field, longitudinal magnetic	(G)
field, magnetic	(G)
field, magnetic leakage	(G)
field, residual magnetic	(G)
field, resultant magnetic	(G)
field of view (FOV)	(J)
field strength	(C), (G)
fill factor	(C), (G)
film contrast	(D)
film speed	(D)
filter	(C), (D), (L)
filter coefficients	(L)
first hit location	(B)
flash magnetization	(G)
flash point	(G)
flaw	(A)
flaw characterization	(A)
floating threshold	(B)
flooded system	(E)
flow	(E)
flow rate	(E)
fluorescence	(D),(F),(G)
fluorescent examination method	(G)
fluorescent magnetic particle inspection	(G)
fluorescent screen	(D)

fluoroscopy	(D)
flux density, magnetic	(G)
flux leakage field	(G)
flux lines	(G)
flux penetration	(G)
focal spot	(D)
focused beam	(I)
fog	(D)
fog density	(D)
footcandle	(F)
fore-line	(E)
fore-line valve	(E)
forepressure	(E)
fore pump	(E)
forward scattered radiation	(D)
frequency	(C)
frequency (fundamental)	(I)
frequency (inspection)	(I)
frequency (pulse repetition)	(I)
fringe	(K)
FRP	(B)
full-wave direct current (FWDC)	(G)
furring	(G)
gage pressure	(E)
gamma (γ)	(H)
gamma-radiography	(D)
gamma ray	(D), (H)
gap scanning	(I)
gas	(E)
gate	(C), (I)
Gaussmeter	(G)
Gaussmeter (Electronic)	(G)
geometric unsharpness	(D)
glare	(L)
glossmeter	(L)
graininess	(D)
grazing incidence	(I)
half-life	(D), (H)
half-value layer	(D), (H)
half-value thickness	(D)
half-wave current (HW)	(G)
Hall Effect	(G)
halogen	(E)
halogen leak detector	(E)
harmonic analysis	(C)
harmonic distortion	(C)
harmonics	(I)
headwave	(I)
helium bombing	(E)
helium drift	(E)
helium leak detector	(E)
hermetically tight seal	(E)
high-amplitude threshold	(B)
high-vacuum	(E)
hit	(B)
holding pump	(E)
holography (acoustic)	(I)
holography (optical)	(K)
hood test	(E)
hot-cathode ionization gage	(E)
hot-filament ionization gage	(E)
hydraulic pressure test	(E)
hydrophilic emulsifier	(F)
hydrostatic test	(E)
hysteresis	(G)
IACS	(C)
ID coil	(C)
ideal gas	(E)
illuminance	(L)
image data file	(D)
image definition	(D)
image processing	(D)
image quality indicator	(H)
image quality indicator (IQI)	(D)
imaging line scanner	(J)
immersion rinse	(F)
immersion testing	(I)
impedance	(C)

impedance (acoustic)	(I)
impedance analysis	(C)
impedance plane diagram	(C)
imperfection	(A)
infrared imaging system	(J)
infrared sensing device	(J)
infrared thermographer	(J)
in-leakage rate	(E)
incremental permeability	(C)
indication	(A), (D), (I)
indications	(C)
indirect exposure	(H)
indirect magnetization	(G)
induced current method	(G)
induced field	(G)
inherent fluorescence	(G)
initial permeability	(C)
initial pulse	(I)
inlet	(E)
inlet flange	(E)
inlet port	(E)
inserted coil	(C)
inside coil	(C)
inside-out testing	(E)
<u>insonification</u>	(I)
inspection	(A), (F)
inspection medium	(G)
instantaneous field of view	(J)
instrumentation dead time	(B)
intensifying screen	(D)
interface	(I)
interference	(K)
interpretation	(A), (B)
interval, arrival time (Δ_{ij})	(B)
ion pump	(E)
ion source	(E)
ionization potential	(E)
ionization vacuum gage	(E)
IQI sensitivity	(D)
irradiance, E	(J)
isolation test	(E)
Kaiser effect	(B)
keV (kilo electron volt)	(D)
Krypton 85	(E)
kV (kilo volt)	(D)
L/D ratio	(H)
Lamb wave	(I)
latent image	(D)
lead screen	(D)
leak	(E)
leak artifact	(E)
leak detector	(E)
leakage field	(G)
leakage rate	(E)
leak testing	(E)
leeches	(G)
lift-off effect	(C)
light	(L)
light intensity	(G)
limiting resolution	(J)
linear accelerator	(D)
linear attenuation coefficient	(H)
linearity (amplitude)	(I)
linearity (time or distance)	(I)
line pair test pattern	(D)
line pairs per millimetre	(D)
line scanner	(J)
lines of force	(G)
lipophilic emulsifier	(F)
liquid penetrant examination	(F)
local magnetization	(G)
location, accuracy	(B)
location, cluster	(B)
location, computed	(B)
location, continuous	(B)
location marker	(D)
location source	(B)
location, zone	(B)

logarithmic (acoustic emission) amplitude distributing g(V)	(B)
longitudinal magnetization	(G)
longitudinal wave	(I)
loss of back reflection	(I)
low-amplitude threshold	(B)
low-energy gamma radiation	(D)
low-energy photon radiation	(H)
low vacuum	(D), (E)
lumen	(L)
luminance	(L)
luminosity	(D)
lusec	(E)
mA (milliampere)	(D)
magnet, permanent	(G)
magnetic field	(G)
magnetic field indicator	(G)
magnetic field meter	(G)
magnetic field strength	(G)
magnetic history	(C)
magnetic hysteresis	(G)
magnetic leakage flux	(C)
magnetic particle examination	(G)
magnetic particle field indicator	(G)
magnetic particle examination flaw indications	(G)
magnetic particles	(G)
magnetic pole	(G)
magnetic saturation	(C)
magnetic storage medium	(D)
magnetic writing	(G)
magnetization, circular	(G)
magnetization, longitudinal	(G)
magnetizing current	(G)
magnetizing force	(G)
markers	(I)
masking	(E)
mass attenuation coefficient	(H)
mass number	(E)
mass spectrometer (M.S.)	(E)
mass spectrometer leak detector	(E)
mass spectrum	(E)
mean free path	(E)
medium vacuum	(E)
MeV (mega or million electron volts)	(D)
micro focus X-ray tube	(D)
micrometre	(E)
micron	(E)
micron of mercury	(E)
milliamperes (mA)	(D)
millimetre of mercury	(E)
minifocus X-ray tube	(D)
minimum detectable leakage rate	(E)
minimum detectable temperature difference (MDTD)	(J)
minimum resolvable temperature difference (MRTD)	(J)
mode	(I)
mode conversion	(I)
moderator	(H)
modulation analysis	(C)
modulation transfer function (MTF)	(J)
molecular flow	(E)
molecular leak	(E)
monochromatic	(K)
monochromator	(L)
multidirectional magnetization	(G)
multiple back reflections	(I)
multiple reflections	(I)
MV (mega or million volt)	(D)
NC	(H)
near field	(I)
near surface discontinuity	(G)
net density	(D)
neutron	(H)
neutron radiography	(D), (H)
newton (N)	(E)
noise	(C), (D), (I)
noise equivalent temperature difference (NETD)	(J)
non-erasable optical data	(D)
non-relevant indication	(A)
nonscreen-type film (direct-type film)	(D)

noncondensable gas	(E)
nonferromagnetic material	(C)
normal incidence (also see straight beam)	(H)
normal incidence (see also straight beam)	(I)
normal permeability	(C)
nuclear activity	(D)
object beam	(K)
object beam angle	(K)
object-film distance	(D)
object plane resolution	(J)
object-scattered neutrons	(H)
occlusion	(E)
off-line testing	(C)
on-line testing	(C)
operating pressure	(B)
optical density	(D)
optical line pair test pattern	(D)
optimum frequency	(C)
outgassing	(E)
outlet pressure	(E)
overall magnetization	(G)
overemulsification	(F)
overload recovery time	(B)
overwashing	(F)
P	(H)
pair production	(D), (H)
palladium barrier leak detector	(E)
paramagnetic material	(C)
partial pressure	(E)
pascal (Pa)	(E)
pascal cubic metres per second	(E)
path length	(K)
path length difference	(K)
pencil beam	(D)
penetrameter	(D)
penetrameter sensitivity	(D)
penetrant	(F)
penetrant comparator	(F)
penetrant, fluorescent	(F)
penetrant, post emulsifiable	(F)
penetrant, solvent-removable	(F)
penetrant, visible	(F)
penetrant, water-washable	(F)
penetration depth	(I)
penetration time	(F)
Penning gage	(E)
perfect gas	(E)
performance check, AE system	(B)
permanent magnet	(G)
permeability	(G)
permeability coefficient	(E)
permeability, a-c	(C)
permeability, d-c	(C)
phase analysis	(C)
phase angle	(C)
phase detection	(C)
phase hologram	(K)
phase-sensitive system	(C)
phase shift	(C)
Phillips ionization gage	(E)
phosphor	(D)
photo fluorography	(D)
photostimulable luminescence	(D)
photostimulable luminescent phosphor	(D)
Pirani gage	(E)
pixel	(D)
pixel, display size	(D)
pixel size	(D)
plate wave	(I)
point signal overload	(B)
point source	(J)
Poiseuille flow	(E)
pole	(G)
polymer technique	(G)
pooling	(F)
post cleaning	(F)
post emulsification	(F)
powder	(G)

powder blower	(G)
precleaning	(F)
pressure, design	(B)
pressure difference	(E)
pressure dye test	(E)
pressure-evacuation test	(E)
pressure probe	(E)
pressure testing	(E)
primary radiation	(D)
probe	(E), (I)
probe coil	(C)
probe coil clearance	(C)
probe gas	(E)
probe test	(E)
process control radiograph	(H)
processing capacity	(B)
processing speed	(B)
processor	(B)
prods	(G)
proportioning probe	(E)
pulse	(I)
pulse echo method	(I)
pulse length	(I)
pulse repetition rate	(I)
pulse turning	(I)
pump-down time	(E)
pump-out tubulation	(E)
quick break	(G)
radiance	(J)
radiant exitance	(J)
radiant flux; radiant power, ϕ_e	(J)
radio frequency (r-f) display	(I)
radiograph	(D), (H)
radiographic contrast	(D)
radiographic equivalence factor	(D)
radiographic exposure	(D)
radiographic inspection	(D), (H)
radiographic quality	(D)
radiographic sensitivity	(D)
radiography	(D), (H)
radioisotope leak test system	(E)
radiological examination	(D), (H)
radiology	(D), (H)
radiometer	(J)
radioscopic inspection	(H)
radioscopy	(D), (H)
range	(I)
range, dynamic	(B)
rare earth screens	(D)
rate event count (Ne)	(B)
rate of rise	(E)
Rayleigh wave	(I)
real image	(K)
real-time radioscopy	(D), (H)
rearm delay time	(B)
recording media	(D)
recording medium	(D)
recording medium	(K)
recovery time	(C)
reference beam	(K)
reference beam angle	(K)
reference block	(I)
reference coil	(C)
reference standard	(C), (G)
reflectance	(J)
reflected temperature	(J)
reflection	(I), (L)
reflector	(I)
reject (suppression)	(I)
rejection level	(C)
relevant indication	(A)
representative quality indicator (RQI)	(D)
residual magnetic field	(G)
residual technique	(G)
resistance (to flow)	(E)
resolution	(I)
resonance method	(I)
response factor	(E)

response time	(E)
resultant field	(G)
retentivity	(G)
ring-down count	(B)
rinse	(F)
roughing	(E)
roughing line	(E)
roughing pump	(E)
S	(H)
sampling probe	(E)
saturation	(I), (L)
saturation level	(I)
saturation, magnetic	(G)
scanning	(I)
scanning index	(I)
scattered energy	(I)
scattered neutrons	(H)
scattering	(E), (I)
Schlieren system	(I)
scintillators and scintillating crystals	(D)
screen	(D)
SE probe	(I)
search unit	(I)
search-gas	(E)
secondary radiation	(D)
selectivity	(C)
sensitivity	(D), (E), (G), (I)
sensitivity control	(C)
sensitivity of leak test	(E)
sensitivity value	(H)
sensor acoustic emission	(B)
shadow	(I)
shear wave	(I)
shear wave search unit (Y cut quartz search unit)	(I)
shim	(D)
shot	(G)
signal	(D)
signal, acoustic emission (emission signal)	(B)
signal amplitude, acoustic emission	(B)
signal gradient	(C)
signal overload level	(B)
signal overload point	(B)
signal-to-noise ratio	(C), (I)
signature, acoustic emission (signature)	(B)
skin depth	(C)
skin effect	(C), (G)
skip distance	(I)
sniffing probe	(E)
solenoid	(G)
solvent remover	(F)
sorption	(E)
source	(D)
source of stimulated acoustic emission	(B)
source-film distance	(D)
spark coil leak detector	(E)
spatial frequency	(J)
speckle	(K)
spectrometer tube	(E)
speed effect	(C)
spray probe	(E)
squealer	(E)
standard	(C)
standard depth of penetration	(C)
standard depth of penetration (SDP)	(C)
standard leak	(E)
standard leakage rate	(E)
standardization, instrument	(A)
step wedge	(D)
step-wedge calibration film	(D)
step-wedge comparison film	(D)
step wedge comparison film	(D)
stimulation	(B)
storage phosphor imaging plate	(D)
straight beam	(I)
subject contrast	(D)
subsurface discontinuity	(G)
summing amplifier (summer, mixer)	(B)
suppression	(I)

surface wave	(I)
surge magnetization	(G)
suspension	(G)
sweep	(I)
swept gain	(I)
swinging field	(G)
system examination threshold	(B)
system induced artifacts	(D)
system noise	(D)
target	(D)
temperature envelope	(F)
tenth-value-layer (TVL)	(D)
test	(A)
test coil	(C)
test frequency	(C)
testing, ultrasonic	(I)
test piece	(G)
test quality level	(C)
test ring	(G)
test surface	(I)
thermal conductivity vacuum gage	(E)
thermal neutrons	(H)
thermal resolution	(J)
thermalization	(H)
thermalization factor	(H)
thermocouple gage	(E)
thermogram	(J)
thermography, infrared	(J)
three way sort	(C)
threshold level	(C)
threshold setting	(C)
threshold voltage	(B)
throttling	(E)
through-coil technique	(G)
through transmission technique	(I)
throughput	(E)
tight	(E)
time, overload recovery	(B)
time, rearm delay	(B)
<u>time of flight</u>	(I)
<u>time of flight diffraction technique</u>	(I)
tomography	(D), (I)
torr	(E)
total cross-section	(H)
total image unsharpness	(D)
tracer gas	(E)
tracer probe leak location	(E)
transducer	(C), (I)
transducer, acoustic emission	(B)
transition flow	(E)
translucent base media	(D)
transmission densitometer	(D)
transmittance	(J)
transmitted film density	(D)
transverse wave	(I)
true attenuation	(I)
true continuous technique	(G)
tube current	(D)
two-way sort	(C)
ultra-high vacuum	(D), (E)
ultrasonic	(I)
ultrasonic leak detector	(E)
ultrasonic noise level	(I)
ultrasonic spectroscopy	(I)
vacuum	(E)
vacuum cassette	(D), (H)
vacuum testing	(E)
vapor pressure	(E)
vee path	(I)
vehicle	(G)
verification, AE system	(B)
vertical limit	(I)
very high vacuum	(D), (E)
vibrothermography	(J)
video presentation	(I)
virtual image	(K)
virtual leak	(E)
viscosity	(F)

viscous flow	(E)
viscous leak	(E)
visibility	(L)
visible light	(F), (G)
visual adaptation	(F)
visual field	(L)
voltage threshold	(B)
wash	(F)
water break test	(G)
water path	(I)
water tolerance	(F)
wave front	(I)
wave guide, acoustic emission	(B)
wave train	(I)
wedge	(I)
wet slurry technique	(G)
wet technique	(G)
wetting action	(F)
wheel search unit	(I)
white light	(G), (L)
wobble	(C)
wrap around	(I)
yoke	(G)
yoke magnetization	(G)
zone	(B)

ASTM International takes no position respecting the validity of any patent rights asserted in connection with any item mentioned in this standard. Users of this standard are expressly advised that determination of the validity of any such patent rights, and the risk of infringement of such rights, are entirely their own responsibility.

This standard is subject to revision at any time by the responsible technical committee and must be reviewed every five years and if not revised, either reapproved or withdrawn. Your comments are invited either for revision of this standard or for additional standards and should be addressed to ASTM International Headquarters. Your comments will receive careful consideration at a meeting of the responsible technical committee, which you may attend. If you feel that your comments have not received a fair hearing you should make your views known to the ASTM Committee on Standards, at the address shown below.

This standard is copyrighted by ASTM International, 100 Barr Harbor Drive, PO Box C700, West Conshohocken, PA 19428-2959, United States. Individual reprints (single or multiple copies) of this standard may be obtained by contacting ASTM at the above address or at 610-832-9585 (phone), 610-832-9555 (fax), or service@astm.org (e-mail); or through the ASTM website (www.astm.org).