



Designation: E 1476 – 97

Standard Guide for Metals Identification, Grade Verification, and Sorting¹

This standard is issued under the fixed designation E 1476; the number immediately following the designation indicates the year of original adoption or, in the case of revision, the year of last revision. A number in parentheses indicates the year of last reapproval. A superscript epsilon (ϵ) indicates an editorial change since the last revision or reapproval.

1. Scope

1.1 This guide is intended for tutorial purposes only. It describes the general requirements, methods, and procedures for the nondestructive identification and sorting of metals.

1.2 It provides guidelines for the selection and use of methods suited to the requirements of particular metals sorting or identification problems.

1.3 *This standard does not purport to address all of the safety concerns, if any, associated with its use. It is the responsibility of the user of this standard to establish appropriate safety and health practices and determine the applicability of regulatory limitations prior to use.* For specific precautionary statements, see Section 10.

2. Referenced Documents

2.1 ASTM Standards:

- E 158 Practice for Fundamental Calculations to Convert Intensities into Concentrations in Optical Emission Spectrochemical Analysis²
- E 305 Practices for Establishing and Controlling Spectrochemical Analytical Curves²
- E 322 Method for X-Ray Emission Spectrometric Analysis of Low-Alloy Steels and Cast Irons³
- E 566 Practice for Electromagnetic (Eddy-Current) Sorting of Ferrous Metals⁴
- E 572 Test Method for X-Ray Emission Spectrometric Analysis of Stainless Steel³
- E 703 Practice for Electromagnetic (Eddy Current) Sorting of Nonferrous Metals⁴
- E 977 Practice for Thermoelectric Sorting of Electrically Conductive Materials⁴
- F 355 Test Method for Shock Absorbing Properties of Playing Surface Systems and Materials⁵
- F 1156 Terminology Relating to Product Counterfeit Protection Systems⁵

¹ This guide is under the jurisdiction of ASTM Committee E-7 on Nondestructive Testing and is the direct responsibility of Subcommittee E07.10 on Emerging NDT Methods.

Current edition approved May 10, 1997. Published January 1998. Originally published as E 1476 – 92. Last previous edition E 1476 – 95.

² *Annual Book of ASTM Standards*, Vol 03.05.

³ *Annual Book of ASTM Standards*, Vol 03.06.

⁴ *Annual Book of ASTM Standards*, Vol 03.03.

⁵ *Annual Book of ASTM Standards*, Vol 15.07.

3. Terminology

3.1 *Definitions*—Terms used in this guide are defined in the standards cited in Section 2 and in current technical literature or dictionaries; however, because a number of terms that are used generally in nondestructive testing have meanings or carry implications unique to metal sorting, they appear with explanation in Appendix X1.

4. Significance and Use

4.1 A major concern of metals producers, warehousemen, and users is to establish and maintain the identity of metals from melting to their final application. This involves the use of standard quality assurance practices and procedures throughout the various stages of manufacturing and processing, at warehouses and materials receiving, and during fabrication and final installation of the product. These practices typically involve standard chemical analyses and physical tests to meet product acceptance standards, which are slow. Several pieces from a production run are usually destroyed or rendered unusable through mechanical and chemical testing, and the results are used to assess the entire lot using statistical methods. Statistical quality assurance methods are usually effective; however, mixed grades, off-chemistry, and nonstandard physical properties remain the primary causes for claims in the metals industry. A more comprehensive verification of product properties is necessary. Nondestructive means are available to supplement conventional metals grade verification techniques, and to monitor chemical and physical properties at selected production stages, in order to assist in maintaining the identities of metals and their consistency in mechanical properties.

4.2 Nondestructive methods have the potential for monitoring grade during production on a continuous or statistical basis, for monitoring properties such as hardness and case depth, and for verifying the effectiveness of heat treatment, cold-working, and the like. They are quite often used in the field for solving problems involving off-grade and mixed-grade materials.

4.3 The nondestructive methods covered in this guide provide both direct and indirect responses to the sample being evaluated. Spectrometric analysis instruments respond to the presence and percents of alloying constituents. The electromagnetic (eddy current) and thermoelectric methods, on the other hand, are among those that respond to properties in the sample that are affected by chemistry and processing, and they

yield indirect information on composition and mechanical properties. In this guide, the spectrometric methods are classified as quantitative, whereas the methods that yield indirect readings are termed qualitative.

4.4 This guide describes a variety of qualitative and quantitative methods. It summarizes the operating principles of each method, provides guidance on where and how each may be applied, gives (when applicable) the precision and bias that may be expected, and assists the investigator in selecting the best candidates for specific grade verification or sorting problems.

4.5 For the purposes of this guide, the term “nondestructive” includes techniques that may require the removal of small amounts of metal during the examination, without affecting the serviceability of the product.

4.6 The nondestructive methods covered in this guide provide quantitative and qualitative information on metals properties; they are listed as follows:

4.6.1 *Quantitative:*

4.6.1.1 X-ray fluorescence spectrometry, and

4.6.1.2 Optical emission spectrometry.

4.6.2 *Qualitative:*

4.6.2.1 Electromagnetic (eddy current),

4.6.2.2 Conductivity/resistivity,

4.6.2.3 Thermoelectric,

4.6.2.4 Chemical spot checks,

4.6.2.5 Triboelectric, and

4.6.2.6 Spark testing (special case).

5. Background

5.1 The standard quality assurance procedures for verifying the composition and physical properties of a metal at a producing facility are through chemical analysis and mechanical testing. These required tests result in the sacrifice of a certain amount of production for the preparation of samples, are costly and time-consuming, and may not provide timely information regarding changes in product quality. In a market in which a single failure can result in heavy litigation and damage costs, the manufacturer requires assurance that his production will meet the customer’s acceptance standards. Nondestructive grade verification provides one means of monitoring production to ensure that the product will meet acceptance requirements.

5.2 Nondestructive methods may be used in conjunction with the accepted standard product quality tests to provide continuous verification that current production lies within the agreed upon acceptance limits specified. In-line electromagnetic tests may be used to indicate the consistency of production. Any deviation from the norms set for the acceptance band will result in automatic alarms, kick-out, or other means of alerting production personnel of a problem. Thus alerted, the mill can determine the cause for the alarm and take corrective action. Portable optical emission spectrometry units may be used to determine the concentrations of critical elements without having to resort to slow physical and chemical analyses. A quality assurance program combining conventional measurements with suitable nondestructive methods can provide effective and timely information on product composition and physical properties. This will result in improved quality

and yield; savings in time, labor, and material; and reduced field failures and claims. This guide provides specific information regarding nondestructive metals identification, grade verification, and sorting methods to assist in selecting the optimum approach to solving specific needs.

5.3 Spectrometric methods are capable of directly indicating the presence and percent of many of the elements that characterize a metal grade. The spectrometric and thermoelectric techniques examine only the outermost surfaces of the sample or material. As a result, for grade verification purposes, it may be necessary to grind sufficiently deep to ensure testing of the base metal for accurate readings. However, grinding may affect the thermoelectric response. The spectrometric methods require physical contact and often some surface preparation. The electromagnetic method, however, does not require contact and very often is suited for on-line, automatic operation. The thermoelectric method, although requiring contact, responds to many of the same parameters that influence the electromagnetic responses. Both respond to chemical composition, processing, and treatments that affect the physical and mechanical properties of the product. Nondestructive methods for indicating the mechanical properties of a metal are beyond the scope of this guide.

5.4 Each method has particular advantages and disadvantages. The selection of suitable candidates for a specific grade verification or sorting application requires an understanding of the technical operating features of each method. These include the precision and bias necessary for the application and practical considerations such as product configuration, surface condition, product and ambient temperatures, environmental constraints, etc.

6. General Procedures

6.1 *Standardization/Calibration:*

6.1.1 Of primary concern in any materials identification or sorting program is delineation of the pertinent product characteristics (such as chemical composition, processing, configuration, and physical properties) and the assignment of acceptance limits to each. Often prescribed by materials specifications, they also may result from quality assurance procedures or by agreement between the producer and the user.

6.1.2 Of equal importance is the selection of reference standards. Quantitative methods employ coupon standards that are representative of the metals or alloy compositions to be verified, and the analytical instrumentation is calibrated against them. The indirect methods, particularly those that respond to physical properties as well as composition, require reference standards that will represent the material specified in composition, mechanical and physical properties, and processing, as well as cover the means and extremes of the acceptance band. Coupon reference standards or product reference standards, or both, may be selected as required.

6.1.2.1 *Coupon Reference Standards*—These are small, easily handled metal panels made to specified chemical compositions. They are available commercially in sets, singly, or to specification. They are useful for instrument calibration, determining separability among metals, and field use with portable equipment. They are not intended to reflect the effects of processing or heat treatment on the acceptability of a product.

6.1.2.2 *Product Reference Standards*—These must represent the product specified in composition and mechanical and physical properties. Ideally, three or more product reference standards covering the mean, plus two or more covering the extremes, should be obtained, suitably catalogued, and marked for proper identification.

6.1.3 Calibration procedures for each method must be followed as specified by the instrument manufacturer. Coupon reference standards are used to calibrate and set up quantitative (spectrometric) or qualitative (thermoelectric and chemical spot check, etc.) verifications, as well as for metals sorting checks on electromagnetic, electrical conductivity, and similar instruments. Rod, bar, wire, and tubular product reference standards are used almost exclusively for the qualitative methods, such as the electromagnetic, electrical conductivity, triboelectric, and spark tests. These are fabricated from the product being manufactured, from samples with compositions and physical properties verified through analytical tests.

6.1.4 The known product reference standards used for the qualitative methods must be representative of the chemistry, processing, surface, and other physical and mechanical parameters that might affect readings. Product standard parameters must be verifiable.

6.1.5 Coupon reference standards are useful for initial calibration adjustments, but final adjustments should be made on standard samples verified as representative of good production pieces.

6.1.6 Product standard samples will disclose potential errors that might result from surface alloy depletion, heavy oxide layers, or hardness variations resulting from processing anomalies. Such known variables must be used to determine final acceptance limits for any test, and they will aid materially in both selecting a method and optimizing the test conditions.

6.2 *Test Piece Requirements:*

6.2.1 The relationship between the standard product samples and test pieces being evaluated must be understood clearly. This is of particular importance when using the electromagnetic method. Composition, size, processing, surface condition, finish, straightness, and temperature must be nominally the same as that represented by the standard test samples. To a lesser degree, this is also true for the thermoelectric method. For the other methods, size, configuration, and mechanical processing usually do not affect composition readings to any significant degree.

6.2.2 The means for applying the test must be controlled. If some surface metal removal is necessary (as it is for spectrometric examinations), the amount of removal, means of removal, and removal location on the test piece must be specified and monitored closely. For electromagnetic examinations, the test piece should be positioned in the same manner relative to the test coil as is the product standard sample. Failure to control the test variables can result in the misidentification of samples.

6.3 *Display and Accept/Reject Criteria:*

6.3.1 Most systems employ some form of visual display or readout to indicate the response to test sample variables. Meter readings, oscilloscope patterns, digital signals, and colored spots (from a reagent in chemical spot check testing) are

typical examples. On instruments with digital or cathode ray tube displays, it is common practice to show the position and extent of adjustable gates for the setting of automatic alarm circuits.

6.3.2 Automatic alarm gates may be positioned and adjusted to be triggered by the presence or absence of a signal of a given amplitude and location. Both of these are adjustable. They are designed for use in automatic or operator-assisted systems to indicate when a product falls outside the acceptance limits, as well as to indicate whether it falls on the high or the low side. Similarly, instruments may be equipped with a computer buss interface for electronic data processing.

6.3.3 As described in the calibration and setup procedure, acceptance and rejection criteria should be established on the basis of specified product parameters. These may be a simple go/no-go selection or a more complex classification based on special requirements. The decision as to how refined a sorting is possible is based on a number of product and measurement variables that are peculiar to the product, inspection method(s), and service requirements. Such decisions should be handled on an individual basis.

7. **Survey of Nondestructive Metals Sorting/Grade Verification Methods**

7.1 *X-ray Fluorescence Spectrometry Method (Fig. 1):*

7.1.1 *Summary of Method*—X-ray fluorescence (XRF) spectrometry is a comparative analytical method that employs low-energy (1 to approximately 30 keV) X-rays or gamma rays to excite characteristic X-rays in the subject material. These X-rays emanate from the individual elements in the subject and may be analyzed by either of the following means: qualitative (recognition of the elements by unique X-ray patterns) or quantitative (identification of characteristic X-rays and measurement of their intensities). Sensitive and sophisticated laboratory XRF systems have been in use for many years. More recently, the advent of improved detectors and microelectronics, coupled with advanced computer technology, have resulted in portable XRF systems capable of yielding accurate readings on the shop floor and in the field.

7.1.2 *Displays*—X-ray fluorescence analyzers are typically programmed to respond to a specific set of alloys selected as

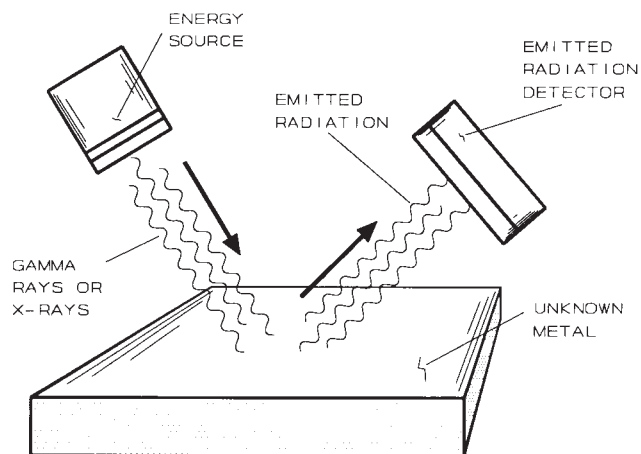

FIG. 1 X-Ray Fluorescence Spectrometry

representative of the composition of the materials examined. The displays are numeric and show the percent concentration of each designated element. Hard-copy printouts of these readings are available. From 1 to 18 elements may be displayed, depending on the equipment design and manufacturer. Eight to ten elements are considered sufficient for precise identification of a wide variety of metals. (Carbon and low-alloy steels are an exception. The XRF method currently does not respond well to elements with an atomic number below 22, and carbon content cannot be determined accurately.)

7.1.3 *Sample Preparation and Operating Precautions*—The test sample must be ground to remove surface oxide layers and the alloy-depleted zone. Exceptions are 300-series stainless steels and other noncorroding superalloys. The XRF source and detector must rest on the sample or be positioned with respect to the sample in a precisely repeatable manner. Sample temperature limits are from 13 to 140°F (–11 to 60°C).

7.1.4 *Calibration*—Calibration instructions are part of the instrumentation program supplied by the manufacturer for each unit. Bias and precision may be determined by using standard test blocks of known composition.

7.1.5 *Speed*—Qualitative sorting may be accomplished in as few as 5 s per sample (exclusive of handling and surface preparation time). Quantitative readings may require from 10 to 200 s. Some sources report that readings may be made in 1 s.

7.1.6 *Accuracy*—Statements of precision and bias vary from manufacturer to manufacturer and from element to element. Users of the XRF method should refer to the instrument reference manuals and to Method E 322 and Test Method E 572.

7.1.7 *Advantages:*

- 7.1.7.1 May be used in quantitative or qualitative mode;
- 7.1.7.2 Provides reasonably accurate alloy identification;
- 7.1.7.3 Portable and easy to use;
- 7.1.7.4 Direct reading; and
- 7.1.7.5 Digital numeric readout/printout available.

7.1.8 *Disadvantages:*

- 7.1.8.1 Careful sample surface preparation often necessary;

7.1.8.2 Elements with atomic numbers of 22 or below (for example, aluminum, carbon, silicon, sulfur, and phosphorus) show poor responses on portable/transportable units;

7.1.8.3 Potential radiation safety hazard; and

7.1.8.4 Alloying constituents with similar characteristic wavelengths may produce uncertain or false results.

7.2 *Optical Emission Spectrometry Method* (Fig. 2):

7.2.1 *Summary of Method*—Emission spectrometry is a comparative analytical method in which a small amount of surface material is removed from the specimen. Early spectrometers were generally limited to use at fixed locations because of their bulk and complexity. Recent developments in sensors and microelectronics have produced transportable systems that can be used on or adjacent to production lines. In some systems, light from the spark discharge is carried by fiber optics to the sensors, where the wavelengths and intensities of the several spectrum constituents are detected and measured. In other systems, the fine particles dislodged by the spark discharge are carried by capillary tube to a chamber in which they are burned under controlled conditions and the spectrum of the flame is analyzed. Photomultipliers are used with diffraction gratings to measure the intensities of preselected analytical lines in the spectrum. The numerical results are displayed in digital form on readouts or printed out in hard copy, or both. In the semiquantitative mode, the information may be displayed on a cathode-ray tube (CRT), and red and green lights at the remote sensor indicate whether the test piece lies within the grade acceptance limits.

7.2.2 *Displays*—Percent concentrations of preselected elements are presented in digital form on a CRT, LCD, or similar display, and they may be printed out on hard copy.

7.2.3 *Sample Preparation and Environment Considerations*—The sample must be free of water, oil, and dirt. Heavy oxide and alloy-depleted layers must be removed by grinding. The grinding must remove paint, coatings, and rust to present an area for placing the spark-discharge gun that has no cracks or porosity. Sample temperature limits are 13 to 140°F (–11 to 60°C).

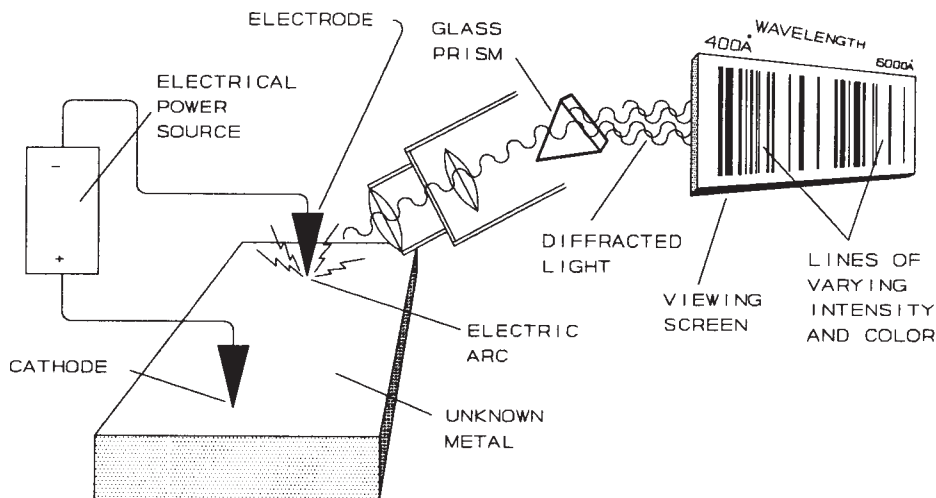

FIG. 2 Optical Emission Spectrometry

7.2.4 *Calibration*—Certified reference standards should be run two or three times and the readings averaged. The concentration-ratio or intensity-ratio methods described in Practice E 158, and the calibration procedure described in Practice E 305, should be followed.

7.2.5 *Speed*—Analysis time ranges from 10 s to 1 min, exclusive of sample preparation time. This time may be reduced somewhat with faster data acquisition. (The spark generator must be held in position for 18 s, limiting the maximum speed for samples with good surfaces.)

7.2.6 *Accuracy*—Statements of precision and bias vary among manufacturers and from element to element. Users of the emission spectrometry method should refer to the instrument reference manuals. Repeatability is very good on standard reference samples. Results on actual test samples may vary because of poor homogeneity, inadequate surface preparation, moisture, and other factors affecting measurement.

7.2.7 *Advantages:*

7.2.7.1 May be operated in a qualitative, comparative, or quantitative mode;

7.2.7.2 Provides reasonably accurate chemical analysis in less than 1 min, exclusive of sample preparation and handling time;

7.2.7.3 Spectrometer may be mobile and operated at or near a production line or in the field;

7.2.7.4 Direct reading; and

7.2.7.5 Hard-copy records available.

7.2.8 *Disadvantages:*

7.2.8.1 Careful surface preparation necessary;

7.2.8.2 Operator fatigue may affect techniques and accuracy of readings;

7.2.8.3 Alloys and trace elements with wavelengths close to those of the unknown elements may produce erroneous determinations, although corrections may be made by analyzing standard samples of the same grade or similar compositions; and

7.2.8.4 Unproven when separation is based on carbon, sulfur, or phosphorus.

7.3 *Electromagnetic Method:*

7.3.1 *Summary of Method*—The electromagnetic (Eddy Current) method is a primary means for high-speed, non-contact, and automatic sorting of ferrous and nonferrous metals. The chemical composition, metallurgical structure, and mechanical properties of metals affect the electromagnetic properties of metals to varying degrees, making this method versatile and useful for metals characterization. A test coil is placed in close proximity to the test piece, and when an alternating current is passed through the coil, an alternating electromagnetic field is induced in the metal under examination. The test coil may be a probe placed on or near the surface of the test piece, or it may be a solenoid that encircles the test piece (around a rod, bar, or pipe). The alternating field induced into the test piece produces reaction currents and fields that are unique to the electromagnetic characteristics of the product. Electromagnetic signal amplitude, phase relationships, and harmonic content combine to characterize the test piece. These are sensed by the test coil and associated instrumentation and analyzed to indicate significant changes in structure, mass,

chemistry, and mechanical properties, as compared to a product reference standard. For purposes of grade verification and sorting, the total signal is compared to that from the standard and analyzed. For specific cases, in which a particular variable in the metal is of interest (for example, hardness), perhaps only one of the electromagnetic signal variables may yield useful results.

7.3.2 *Displays*—The electromagnetic method is indirect in that its effectiveness relies on the correlation of changes in the properties of metals being examined with measurable electromagnetic responses. These responses are vector quantities containing frequency, amplitude, and phase information, and they are often displayed on a CRT, on which the signals from specific grades result in groupings that are unique in phase (angle) and amplitude with respect to other metals. Such groupings on a CRT may be interpreted by an operator who rejects all test pieces falling out of the acceptance limits set for a given product. Electronic threshold (box) gates may be generated and adjusted to encompass the acceptance limits, so that any signal falling outside of these limits will cause automatic rejection of the sample. Similarly, the signal from the test sample may be analyzed in a comparator arrangement, in which the voltage from the test sample is compared in phase and amplitude with a standard voltage that is representative of the grade of the product specified. The reference standard voltage represents the grade, heat treatment, hardness, or other significant parameter of the product, and acceptance limits are adjusted accordingly. The differences between the reference standard and the test sample voltages produce an error signal an exact match resulting in a zero reading. Limits bracketing zero may be established to include acceptable variations in product parameters, exclude out-of-tolerance material, and thus permit automatic three-way sorting for acceptable, off-grade low, and off-grade high product. Guidance for the selection of samples, calibration, and establishing acceptance limits are given in Practice E 566 for sorting of nonferrous metals and in Practice E 703 for sorting of ferrous metals. Electromagnetic signal amplitude, harmonic content, and phase shifts combine to characterize the test piece and relate to material structure, size, chemistry, and mechanical properties. For most grade verification problems, the total signal or the fundamental frequency signal is analyzed. For specific cases, perhaps only one or two components of the total signal are selected as responsive to the variable (for example, hardness) of interest.

NOTE 1—The electromagnetic method has the potential for on-line grade verification or process monitoring of metals at elevated processing temperatures. Water-cooled encircling coils suitable for use on wire, rod, bar, and tubular products are available for use at a temperature of 2000°F (1100°C) and are used with suitable instrumentation for these purposes.

7.3.3 *Calibration*—Certification of a sorting system relies on a calibration based on standard reference samples of the product that are representative of the size, nominal chemical composition, and processing specified for the product. Two or three samples each, of product representing the means and extremes of the acceptance range, should be used, and system adjustments should be made accordingly. Practices E 566 and E 703 list steps for the selection of reference samples, setting

of acceptance limits and calibration procedures, and precautions and interferences that should be observed. New microprocessor-based instrumentation provides a different approach to calibration. Data for a large number of test specimens may be stored, permitting an accurate assessment of the normal distribution of product variables and a highly accurate calibration of grade verification results.

7.3.4 Speed—The electromagnetic method is capable of high-speed operation. Speed is dependent on the geometry of the part, test frequency, time necessary to make a grade determination, and product handling considerations. The relationship of the test coil to the part must be such that the electromagnetic signals obtained from piece to piece are consistent, so that the signal is not affected by part geometry or position. Edge effect and end effect interferences must be avoided. The details of size and frequency limitations on test speed are beyond the scope of this guide, but in most cases sorting speed is limited by product handling and mechanical considerations rather than by limitations imposed by the method.

7.3.5 Accuracy—Verification of sorting accuracy must rely on other (analytical) methods to establish product properties and acceptance limits. Highly reliable sorting and grade verification is possible when suitably stabilized excitation and measuring instrumentation is used, along with mechanical handling that maintains reasonably precise relationships between the test coil and the product.

7.3.6 Advantages:

- 7.3.6.1 Contact not necessary in most cases;
- 7.3.6.2 Portable/transportable as well as fixed installation;
- 7.3.6.3 No surface preparation normally necessary;
- 7.3.6.4 High-speed, depending on part size and frequency;
- 7.3.6.5 Automatic operation readily achieved;
- 7.3.6.6 Responsive to mechanical and physical properties not measurable by other methods, such as those resulting from heat treating or mechanical working; and
- 7.3.6.7 Adaptable to in-line, hot product use.

7.3.7 Disadvantages:

- 7.3.7.1 Not quantitative, that is, requires supporting quantitative measurements to establish operating parameters;
- 7.3.7.2 Sensitivity to a wide range of variables can confuse the results, and dissimilar materials may exhibit similar electromagnetic characteristics, requiring supplemental tests using other methods;
- 7.3.7.3 Coil and part temperatures can cause drift; and
- 7.3.7.4 Where sorting is to be conducted on the basis of composition alone, the response to heat treatment, mechanical working, and other processing variables can result in the misidentification of metals with the same composition.

7.3.7.3 Coil and part temperatures can cause drift; and

7.3.7.4 Where sorting is to be conducted on the basis of composition alone, the response to heat treatment, mechanical working, and other processing variables can result in the misidentification of metals with the same composition.

7.4 Electrical Resistivity Method:

7.4.1 Summary of Method—Electrical resistivity is a property of metals that is affected by, among other factors, chemical composition and grain structure, and it can be considered as a means for sorting electrically conductive materials. The resistivity method utilizes a probe with four in-line, equally spaced pins (electrodes) placed in contact with a metal. A constant current is passed through the material from the outer two electrodes, and a potential drop is measured across the inner

two electrodes. The potential drop is usually converted to resistivity and displayed on a conventional meter or digital readout. The readout may refer to the absolute resistivity of the material, or it may be a relative resistivity value. This measurement requires direct, uniform contact with the material surface using the four-point probe. The test is conducted by placing the test probe on the object whose electrical resistivity is to be determined, applying the current, and reading the meter.

7.4.2 Displays—The display reads out either resistivity or conductivity on an analog or digital display.

7.4.3 Sample Preparation and Environmental Considerations—Epoxyes, paints, and other nonconductive surface coatings, as well as surface oxides, dirt, oil, and grease must be removed, or they will prevent the current from entering the material. In order to avoid errors, the surface must be free of moisture and at a uniform, known temperature.

7.4.4 Calibration—Reference standard samples with known compositions, physical properties, and processing are necessary. Also, they must be of the same thickness and geometry as the materials being investigated. Edges, corners, and other geometric discontinuities can affect readings and therefore must be avoided. Readings should be taken at selected locations in order to characterize the test samples while avoiding geometries that can cause errors. Several readings should be taken and averaged for each selected location to provide base references. During instrument calibration, the precautions regarding surface preparation, edge effects, and sample geometry must be observed.

7.4.5 Speed—Readings may be taken in approximately 1 s, exclusive of surface preparation time.

7.4.6 Advantages:

- 7.4.6.1 Simple to use and read;
- 7.4.6.2 Rapid;
- 7.4.6.3 Adaptable to automatic operation;
- 7.4.6.4 Portable, that is, usable in situ and on stacked product; and
- 7.4.6.5 Usable on a wide range of ferrous and nonferrous metals.

7.4.7 Disadvantages:

- 7.4.7.1 Requires uniform electrical contact;
- 7.4.7.2 Thickness and geometry variations affect readings;
- 7.4.7.3 Discontinuities such as porosity, voids, cracks, and inclusions may cause errors;
- 7.4.7.4 Variations in probe contact pressure and minor variations in surface condition may result in errors; and
- 7.4.7.5 Electrical conductivity changes resulting from heat treatment and mechanical working can result in different materials appearing to be similar or materials with the same composition appearing to be different.

7.4.7.5 Electrical conductivity changes resulting from heat treatment and mechanical working can result in different materials appearing to be similar or materials with the same composition appearing to be different.

7.5 Thermoelectric Method (Fig. 3):

7.5.1 Summary of Method—The thermoelectric method makes use of the thermocouple principle, in which a heated junction of dissimilar metals creates a voltage (formally referred to as the Seebeck Effect). Employing a heated metal-tipped probe and an ambient temperature probe (or two probes

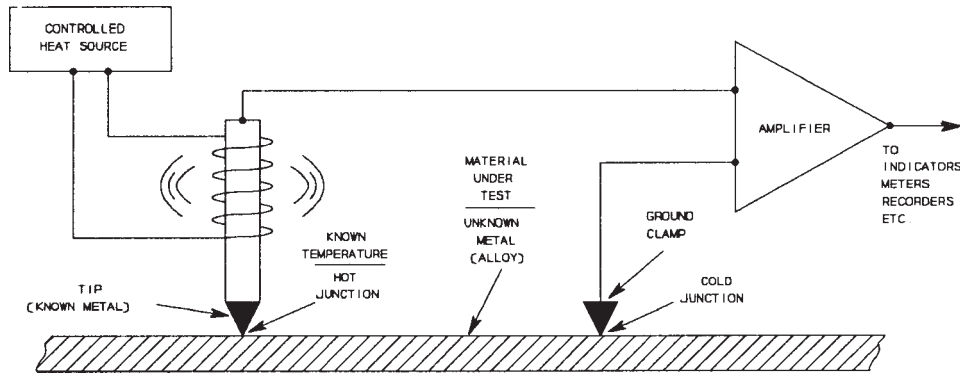

FIG. 3 Typical Circuit used in Thermoelectric Sorting Instruments

heated or cooled to two different temperatures), voltage readings are established for known reference standards. The readings displayed are representative of the known standards and must be within the range of the instrument display. They are compared with those obtained from the test samples. In operation, the heated (300 to 390°F or 150 to 200°C) test probes are placed in contact with the surface of the part under testing, and readings are taken. Sorting is based on the acceptance limits and on known tolerances above and below the established means.

7.5.2 *Displays*—Currently available devices employ digital voltmeters or analog null meters, or both. Light bar, chart recorder, direct computer, or microprocessor entry may be used.

7.5.3 *Sample Preparation and Environmental Conditions*—The thermoelectric effect requires electrical contact with the test piece. The surface must therefore be free of nonconductive paint and protective coatings, as well as oxide layers. Since the probe covers a small area, only a small area need be prepared. No shock or environmental hazards are involved.

7.5.4 *Calibration*—Calibration should be performed after the instrument has been turned on and warmed up, as well as periodically throughout testing. Refer to Practice E 977 for the selection of reference standards and precautions associated with calibration. Calibration coupons with known compositions should be used as a reference base. As with other qualitative means in which sorting is made by the comparison of reference standard and actual product sample readings, all parameters affecting the acceptance range should be known and measurable.

7.5.5 *Speed*—Individual readings may require less than 1 s, exclusive of surface preparation time.

7.5.6 *Accuracy*—Sorting by the go/no-go method is affected by the similarity between the standards used and the acceptance band for the samples under testing. Users of this method should refer to the manufacturer’s specifications regarding repeatability.

7.5.7 *Advantages:*

- 7.5.7.1 Nondestructive;
- 7.5.7.2 Probe pressure, sample size, and geometry not variables;
- 7.5.7.3 Portable, that is, may be used on stacked or bundled product or in situ; and
- 7.5.7.4 Rapid.

7.5.8 *Disadvantages:*

- 7.5.8.1 Requires an electrically conductive surface;
- 7.5.8.2 Some surface preparation may be necessary;
- 7.5.8.3 Least effective for aluminum alloys and austenitic stainless steels; and
- 7.5.8.4 Thermoelectric changes resulting from heat treatment and mechanical working can result in metals that are similar in composition appearing to be different and dissimilar metals appearing to be similar.

7.6 *Chemical Spot Test Method* (Fig. 4):

7.6.1 *Summary of Method*—The chemical spot test method uses the reactions between certain chemicals and metals that produce colors and permit one alloy to be distinguished from another. A typical unit electrically removes a minute amount of metal onto moistened filter paper. One or two drops of reagent are placed on the paper to develop a distinct color reaction. Normal color perception is required because operators are evaluating color changes. Sets of reagents are available to cover different metals groups such as aluminum, carbon and alloy steels, and brass and bronze.

7.6.2 *Interpretation*—Color charts are available for many different metals groups and reagents, but not for all. Using the proper chart for the metals group being investigated, the operator makes the identification based on the color match

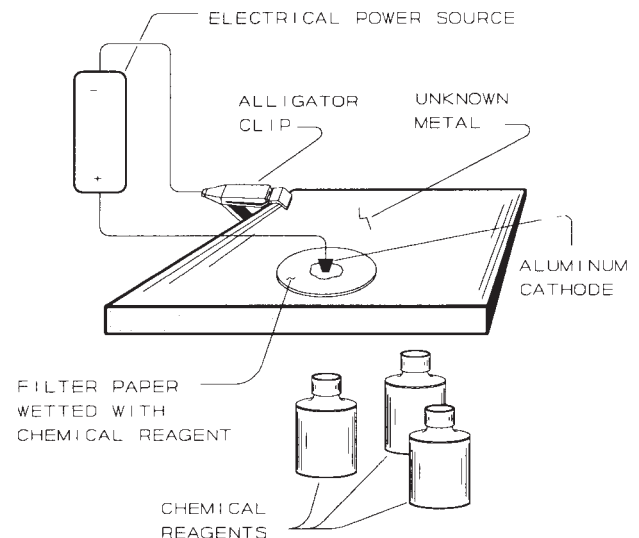

FIG. 4 Apparatus Associated with Chemical Spot Testing

between the filter paper spot and the chart. It is advisable to perform tests with known standards and reagent kits in order to establish a catalog of responses for the metals under testing.

7.6.3 Sample Preparation and Environmental Considerations—The amount of metal removed by this procedure is 0.00004 in. (0.0001 mm), maximum. For reliable alloy identification, it is necessary to remove oxide and alloy-depleted layers prior to the spot check examination. Furthermore, all paint, protective coatings, oil, dirt, and grease must be removed.

7.6.4 Calibration—Performance should be verified routinely, using standard coupons.

7.6.5 Speed—Approximately 60 s is necessary to perform a determination for a single alloying element. It may be necessary to perform two or more tests to separate one alloy from another.

7.6.6 Advantages:

- 7.6.6.1 Relatively simple to use;
- 7.6.6.2 Portable, that is, may be used at almost any location and on nearly any size component;
- 7.6.6.3 Reagent kits are available for a wide range of ferrous and nonferrous alloys;

7.6.6.4 Essentially nondestructive; and

7.6.6.5 May be used to identify platings and metallic coatings.

7.6.7 Disadvantages:

- 7.6.7.1 Slow;
- 7.6.7.2 Careful surface preparation necessary;
- 7.6.7.3 Chemicals have a finite shelf life;
- 7.6.7.4 Readout is subjective and based on color perception; and
- 7.6.7.5 Temperature of the test piece may affect results.

7.7 Triboelectric Method:

7.7.1 Summary of Method—Triboelectricity results whenever two dissimilar metals rub against one another. Although these voltages are in the microvolt to millivolt range, they are distinctive enough in certain cases to permit sorting. Basic equipment consists of a “gun” holding an oscillating cylindrical rod that provides the rubbing motion when held against the metal under testing. The triboelectric voltage thus generated is processed and displayed. An alternative application uses two files: one to break the oxide layer and provide a reference connection, and the other to generate the triboelectric voltage.

7.7.2 Display—Triboelectric voltage may be read directly from an analog or digital meter, or it may be used in the comparator mode, in which the voltage is balanced against a reference voltage that is internally generated and thus responds to a difference or change in the triboelectric signal. Both types are simple to use. The “gun” with the reciprocating rod is held against the test piece to provide electrical contact, and the instrument amplifies and processes the resultant voltage. The file-type instrument is operated by making one stroke to break through the oxide, and repeated strokes by the second file produces the triboelectric voltage. A clip with sharp jaws is used in some cases to replace the first file. Go/no-go signal lamps may be used to identify out-of-specification materials.

7.7.3 Sample Preparation and Environmental Considerations—As with all surface contact methods, heavy oxide and alloy-depleted layers must be removed for repeatable results. Special environment hazards are not involved.

7.7.4 Calibration—Test blocks of known composition should be used to establish reference bases and determine satisfactory operation. For most sorting applications, however, it is important that the final instrument setup be made on samples of the product in which the variables of interest are represented and have been measured by other means.

7.7.5 Speed—Response time is on the order of 1 s.

7.7.6 Accuracy—Because of the limited use of this method, little data on accuracy are available. The method has been found to be mostly ineffective on carbon and alloy steels.

7.7.7 Advantages:

- 7.7.7.1 Simple to use;
- 7.7.7.2 Fast;
- 7.7.7.3 May be used on a wide variety of material sizes;
- 7.7.7.4 Geometry independent;
- 7.7.7.5 Highly portable, that is, used in situ and on bundled and stacked material; and
- 7.7.7.6 Rugged and not adversely affected by environment.

7.7.8 Disadvantages:

- 7.7.8.1 Leaves permanent marking on specimen surface;
- 7.7.8.2 Not well-suited to mechanized operation;
- 7.7.8.3 Normally used only when other methods are ineffective;
- 7.7.8.4 Readings affected by oxide and alloy-depleted layers;
- 7.7.8.5 Oscillator rod pressure affects readings; and
- 7.7.8.6 Not suited for carbon and alloy steels.

7.8 Spark Testing Method (Fig. 5):

7.8.1 Summary of Method—The basis of this method is that certain alloys oxidize rapidly at high temperatures. When a high-speed abrasive wheel is held against a metal, the fine particles that are torn loose are heated to incandescence (spark)

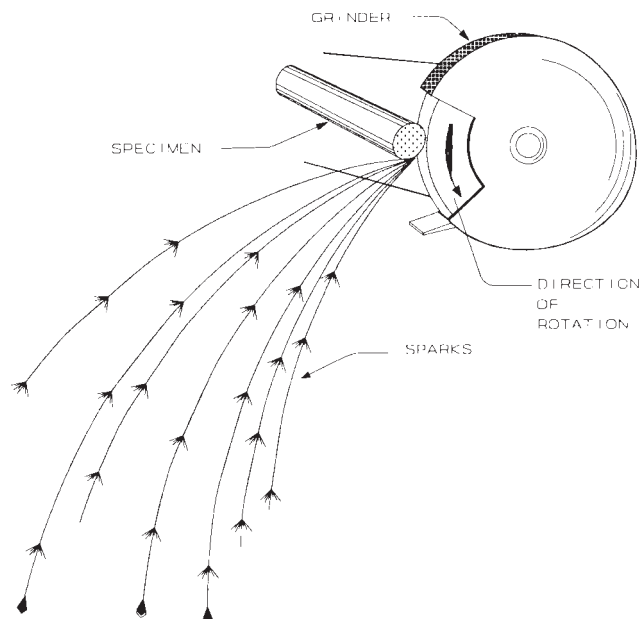

FIG. 5 Typical Spark Test

by the friction and consequently oxidized. Material identification is based on the visible characteristics of the sparks produced such as colors, bursts, shapes, sizes, and distributions of the spark stream. Spark testing is commonly used for the identification or separation of carbon and alloy steel grades. It may also be used to sort metals on the basis of gross surface (chemistry) segregation, carburization, and decarburization. It is a highly subjective method, requiring considerable operator training, experience, and skill. The distinction between the spark characteristics of one piece and those of another is primarily a function of chemistry. The operator compares the spark characteristics of the test piece with those from samples on hand or from memory. Because of elemental interactions, it is generally not possible to examine a spark and arrive at an elemental analysis. However, experienced operators can estimate certain elements, such as carbon content, within a few percent. In practice, the operator must learn the spark pattern for each material likely to be encountered.

7.8.2 *Interpretation*—There is no instrumentation involved in the spark testing method. Rather, the operator is trained to recognize the patterns listed in 7.8.1 and to make judgements as to the presence and degree of alloying elements.

7.8.3 *Sample Preparation and Environmental Considerations*—No sample preparation is necessary, keeping in mind that the presence of heavy oxide and alloy-depleted layers will affect the generated spark. As stated earlier, it may be desirable to investigate these zones. The operator must otherwise grind through them to arrive at a level at which the spark pattern is representative of the composition of the material. Spark testing may be conducted at nearly any stage of metals production. Areas with strong breezes from fans or open doors must be avoided because the breeze might distort the spark stream, causing misinterpretation. Lighting is important, and low to moderate white light provides the proper illumination for spark testing. Other lighting conditions are permissible, although they may affect the perception of the operator. Bright light should be avoided.

7.8.4 *Calibration*—Reference samples or coupons of product that are representative of the composition and processing of the material being examined must be available. The grinding wheel must be within the stated limits for diameter, width, and prescribed grit. Because of the highly subjective nature of this test, the operator should on occasion check his perception of spark patterns during an operating turn, and his superior should subject him to evaluation using unknown samples at regular intervals.

7.8.5 *Speed*—A skilled operator can make a determination on the acceptability of a material in a few seconds.

7.8.6 *Accuracy*—Skilled operators have records of correct calls well into the 90 % range; however, fatigue, distractions, and physiological factors can affect performance materially. In many metals-producing plants, spark testing is conducted at several locations in the production line in order to reduce the effects of operator error.

7.8.7 *Advantages:*

- 7.8.7.1 Rapid and economical;
- 7.8.7.2 Can be applied at nearly any stage of production;
- 7.8.7.3 Little or no surface preparation required;

- 7.8.7.4 Sample cutting unnecessary;
 - 7.8.7.5 Suitable for most ferrous and nonferrous alloys;
 - 7.8.7.6 Size independent, that is, may be used on stacked or bundled pieces; and
 - 7.8.7.7 Simple, portable, and may be used almost anywhere there is a suitable power source.
- 7.8.8 *Disadvantages:*
- 7.8.8.1 Considerable operator training, skill, and experience required;
 - 7.8.8.2 Results are mainly qualitative and are highly dependent on operator skill, emotional, and physical condition;
 - 7.8.8.3 Not applicable to mechanized or automatic operation;
 - 7.8.8.4 Destructive by nature, that is, can result in excessive metal removal because of heavy wheel pressure or prolonged grinding, or both;
 - 7.8.8.5 When used outdoors or in other bright light, shading is necessary; and
 - 7.8.8.6 Will not detect copper or lead.

8. Selection of Method

8.1 *General*—Selection of the appropriate metals identification method is a somewhat complex process, and it is not limited simply to the sensitivity and accuracy of the technique employed. The following paragraphs outline some of the material and operational parameters that should be considered when planning a metals identification, grade verification, or sorting installation. Failure to do so may negate the effectiveness of the test.

8.2 *Metals Grade Verification Parameters:*

8.2.1 *Material to Be Examined:*

- 8.2.1.1 Grade (composition).
- 8.2.1.2 Size(s), shape, and weight.
- 8.2.1.3 Testing on-line or off-line?
- 8.2.1.4 Are the specified mechanical properties acquired through heat-treatment, quench and temper, warm work, cold work, etc.?
- 8.2.1.5 How much product is to be examined? Pieces per turn? Conveyor speeds?
- 8.2.1.6 Statistical or 100 % sampling?

8.2.2 *Information Required:*

- 8.2.2.1 Quantitative (direct readout/printout).
- 8.2.2.2 Qualitative (go/no-go).
- 8.2.2.3 Qualitative with quantitative backup.
- 8.2.3 Eliminate methods not suitable for the identification or sorting task.
- 8.2.4 Rank remaining methods by technical merit and cost.
- 8.2.5 Select two or more candidates for evaluation under real or simulated operating conditions.

8.3 *Further Considerations*—The selection of method(s) for a particular application must take into account the population from which the identification is to be made. If a particular material or condition is to be identified, it is necessary to ensure that the examination(s) selected can discriminate the differences in grade or condition from all other specimens in the population. If the number and sources of samples are limited, a simple procedure using one method may suffice. When the number of samples is large and the sources are varied, the chances for errors increase, and a more complex

program involving reevaluation and the use of more than one method may become necessary. It is sound practice to require the material supplier to identify the required material in a way that separates it from all other materials in the plant with which the subject material might become mixed, and to supply evidence that the procedure will do so.

9. Characteristics, Applications, and Limitations of Metals Grade Identification, Verification, and Sorting Methods

9.1 Capabilities of Metals Grade Identification Methods (Table 1):

9.1.1 Table 1 lists the capabilities of the several nondestructive methods covered in this guide.

9.1.2 It is intended for ready reference and the identification of primary candidates for specific grade-mix problems.

9.1.3 The extreme left-hand column lists metals and metals properties that may define a specific grade.

9.1.4 The columns to the right of the metals properties column list the various nondestructive methods covered in this guide, with coded indications concerning their applicability, as well as general and specific notes to aid in the selection process.

TABLE 1 Metals Grade Identification Methods Capabilities

NOTE 1—E = excellent; G = good; F = fair; P = poor; N = not applicable; A = direct-reading quantitative; and B = indirect-reading qualitative.

Metals Properties	X-Ray Spectrometry	Emission Spectrometry	Electromagnetic (Eddy Current)	Conductivity Resistivity	Thermo-electric (Seebeck)	Chemical Spot Test	Tribo-Electric	Spark Testing	Notes
A. Chemical composition	E, A ^A	E, A	G, B	F, B	G, B	G, A ^B	F, B ^C	G, B	Spectrometry is the best method.
Identification/response to specific alloy	E, A	E, A	G, B ^D	F	G, B ^E	E	F	G	Spectrometry and chemical spot test are widely used.
Response to surface chemistry	E, A	E, A	F–G, B	F, B	E, B	E	N	N	
B. Physical properties:	N	N	F–G, B ^F	N	G, B ^G	N	N	N	Electromagnetic, thermo-electric, and conductivity responses are all relative and based on known responses to measured variables.
Hardness (surface, through thickness)	N	N	F, B ^F	N	G, B ^G	N	N	N	
Tensile strength	N	N	F–G, B ^F	N	G, B ^G	N	N	N	
Yield strength	N	N	F–G, B ^F	N	G, B ^G	N	N	N	
C. Monitoring process variables:	N	N	F–G, B ^F	F, B	F, B	N	N	N	Electromagnetic, thermo-electric, and conductivity responses are all relative and based on known responses to measured variables.
Cold work	N	N	F–G, B	F, B	F–G, B	N	N	N	
Warm work	N	N	F–G, B	F, B	F–G, B	N	N	N	
Anneal	N	N	F–G, B	F, B	F–G, B	N	N	N	
Case/through hardening	N	N	F–G, B	F, B	F–G, B	N	N	N	
Temper	N	N	F–G, B	F, B	F–G, B	N	N	N	

^A Not suitable for low atomic number alloys such as carbon, silicon, and phosphorous.

^B Single element per spot test.

^C Not suitable for steels.

^D Responds well to manganese reversion in steel.

^E Responds well to electrically or thermally active elements, or both.

^F Requires controlled processing, composition, etc.

^G Thermoelectric properties influenced by metallurgical exchange in ferrous materials.

9.2 *Application Characteristics of Metals Grade Identification Methods* (Table 2):

9.2.1 Table 2 relates candidate methods to operational and environmental conditions that influence the selection process.

9.2.2 It is designed as a ready reference guide for the identification of operational and environmental factors that may influence the choice of a specific method over several candidate systems.

9.2.3 The extreme left-hand column of Table 2 lists major operational and environmental parameters to be addressed when planning a grade verification operation.

9.2.4 The columns to the right of the applications variables column list the several nondestructive grade verification methods in this guide, along with coded indications concerning their applicability, as well as general and specific notes to aid in the selection process.

TABLE 2 Application Characteristics of Metals Grade Verification Methods

NOTE 1—E = excellent; G = good; F = fair; P = poor; N = not applicable; A = direct-reading quantitative; and B = indirect-reading qualitative.

Application Characteristic	X-Ray Spectrometry	Emission Spectrometry	Electro-magnetic (Eddy Current)	Conductivity Resistivity	Thermoelectric (Seebeck)	Chemical Spot Test	Tribo-Electric	Spark Testing	Notes
A. Direct-read/response:	E, A	E, A	G, B	G, B	G, B	B ^A	G, B	N, B	
1. Composition	E ^B	E	G ^C	G ^C	G ^C	E	F–G	N	
2. Physical properties	N	N	G	G	G	N	N	N	
B. Automatic operation	E	E	E	G	E	N	N	N	
C. Permanent record	yes	yes	yes	yes	yes	possible	yes	no	
D. Portable	yes	mobile	yes	yes	yes	yes	yes	yes	
E. Environment:									
1. Heat/cold	13–140°F	13–140°F	G ^D	F	E ^E	N	N	G	
2. Vibration	N	N	G	P	G	N	N	G	
3. Moisture	N	N	G	P	G	P	N	G	
4. Dirt, oil, mill scale	N	N	G ^F	N	G ^F	G ^F	F ^F	G	
5. Illumination	N	N	G	G	G	G ^G	G	G ^G	
F. Relative speed	moderate	moderate	high	medium high	high	slow	medium high	medium high	

^A Requires color determination by perception: single element per test.

^B Not responsive to elements with atomic numbers of 22 or less.

^C Responses to composition and processing. Variables must be determined and analyzed.

^D Variations ± 20° not troublesome; can operate at any of a wide range of temperatures if variations are limited.

^E If known standards and test piece are at same temperature, results are accurate up to 500°F.

^F Heavy mill scale must be removed.

^G Moderate lighting necessary.

10. Precautions and Disclaimers

10.1 This guide neither endorses nor recommends the use of any of the methods covered. There is no one nondestructive method capable of identifying and sorting every possible metal or alloy combination. Since there are more than 10 000 metals, and each has a lower and upper specification limit, the number of possible variables is nearly limitless.

10.2 Each method must be examined based on its effectiveness for the specific application and any hazards associated with its use.

10.3 A combination of methods (including the very simple and safe use of a magnet) may be required for any complex, total inspection.

11. Keywords

11.1 chemical spot check; curie temperature; eddy current; electrical conductivity; electromagnetic; metals grade; metals grade identification; metals grade verification/sorting; nondestructive; optical emission spectrometry; Seebeck Effect; spark testing; thermoelectric; triboelectric; X-ray fluorescence spectrometry

APPENDIX

(Nonmandatory Information)

X1. GLOSSARY OF TERMS USED IN THIS GUIDE

alarm gate—an adjustable electronic means for selecting indications (signals) whose amplitude, timing, frequency components, and other identifiable characteristics may be unique for a given material, permitting adjustment of the gate to accept or reject such signals for automatic sorting.

calibrate—to establish the indication or the output of a measuring device with respect to that of a standard.

calibration, instrument—the comparison of an instrument or the adjustment of an instrument to a known reference(s) often traceable to the National Institutes of Standards and Technology.

calibration, internal—the adjustment of internal instrument circuitry to conform to manufacturers specification; usually performed only by the manufacturer or authorized representative.

coupon—see **standard known**.

display—in instrumentation, the form in which test results are viewed by the performer of the examination such as (but not limited to) digital or analog meter, printer, chart recorder, light emitting diode, liquid crystal, oscilloscope pattern, computer monitor.

eddy current—an electrical current caused to flow in a closed path, in a conductor by electromagnetic induction.

electromagnetic testing—in metal sorting, a metal employing electromagnetic energy for examining materials; primarily ferrous and non-ferrous metals, for composition, mechanical and physical properties.

grade—a designation, assigned by the manufacturer, usually in numeric or alphanumeric form, used to identify materials having specified chemical compositions, processing, and mechanical properties.

grade identification, metals—determination of a grade of metal to assure compliance with those properties specified and thus establish its identity.

grade sorting, metals—distinguishing a specific grade among mixed grades.

grade verification, metals—confirmation that the material under evaluation conforms to stated grade specifications.

magnetic permeability—the ease with which a magnetic field or flux can be set up in a magnetic circuit.

DISCUSSION—It is not a constant value for a given material but is a ratio. At any given value of magnetizing force, permeability is B/H , the ratio of flux density, B , to magnetizing force, H . It is characteristic of the material being magnetized and is dependent upon alloy, heat treatment, and geometric configuration. Whereas the relative permeability of free space is 1.0, relative permeabilities for metals range from less than one for diamagnetic metals to several thousand for high-permeability ferromagnetic metals.

nondestructive testing—the general term applied to materials evaluation methods used to assess the suitability of materials for specified applications without damaging the specimen or impairing its usefulness in any way; however, in metal sorting, methods that affect the surface are sometimes considered nondestructive.

reagent—a chemical used to react with another chemical often to confirm or deny the presence of a second chemical (see Terminology F 1156); in metal sorting; the second chemical is a metallic element.

seebeck effect—generation of an electromotive force (emf) as a result of a circuit containing two dissimilar metallic electrically conductive materials having two junctions between the materials at different temperatures, and is the basis for thermocouples.

DISCUSSION—In standard thermocouples, temperature is determined from the emf produced. In metal sorting, temperature differences are held constant and the emf changes with the introduction of specific test pieces as one of the dissimilar metals.

spark testing—a test in which the optical emission characteristics (this is, color, intensity, shape, distribution) of sparks generated by a device such as a grinding wheel being applied to a metal surface are indicative of that metal's chemistry.

spectrometer, optical emission—an instrument that measures percent concentrations of elements in samples of metals and other materials.

DISCUSSION—When a small spot on the surface of the sample is vaporized by an electric spark, arc, laser or other means the characteristic near ultraviolet, visible or near infrared wavelengths of light emitted by each element are measured with a diffraction grating and photographic plates or with an array of photo-detectors.

spectrometer, x-ray fluorescence—an instrumented analytical method in which the wavelengths of characteristic emissions (spectra) generated at the surface of a specimen are analyzed to indicate the presence and amount of chemical constituents in that material.

spectrometric analysis—the use of optical emission or x-ray emission spectrum analysis techniques for the determination of the chemical composition of a specimen.

spot test, chemical—a test that determines the presence or absence of certain metallic elements in a test specimen, by color variation, through the use of reagents.

standard, product—a sample of a finished product that is known to be within specifications, and against which another sample may be compared.

standard, known—a reference material (sometimes called a coupon) in which relevant chemical and physical characteristics are known and measurable, and which is used as a comparison reference for examining unknowns.

standardization—the procedure used to verify or adjust instrument response to conform to the data established during calibration.

thermoelectric effect—an electromotive force (emf) generated by a temperature difference (Seebeck Effect); the principal of operation used in a metal sorting technique.

triboelectric effect—phenomenon of producing an electrostatic voltage differential between dissimilar metals by frictional contact (see Test Method F 355); in metal sorting the measurement of the voltage differential can be used as a means of distinguishing between dissimilar metals.

wavelength—the distance in the direction of propagation between two successive points where the phase (amplitude and direction) is the same.

ASTM International takes no position respecting the validity of any patent rights asserted in connection with any item mentioned in this standard. Users of this standard are expressly advised that determination of the validity of any such patent rights, and the risk of infringement of such rights, are entirely their own responsibility.

This standard is subject to revision at any time by the responsible technical committee and must be reviewed every five years and if not revised, either reapproved or withdrawn. Your comments are invited either for revision of this standard or for additional standards and should be addressed to ASTM International Headquarters. Your comments will receive careful consideration at a meeting of the responsible technical committee, which you may attend. If you feel that your comments have not received a fair hearing you should make your views known to the ASTM Committee on Standards, at the address shown below.

This standard is copyrighted by ASTM International, 100 Barr Harbor Drive, PO Box C700, West Conshohocken, PA 19428-2959, United States. Individual reprints (single or multiple copies) of this standard may be obtained by contacting ASTM at the above address or at 610-832-9585 (phone), 610-832-9555 (fax), or service@astm.org (e-mail); or through the ASTM website (www.astm.org).