



Standard Practice for Ultrasonic Contact Examination of Weldments¹

This standard is issued under the fixed designation E 164; the number immediately following the designation indicates the year of original adoption or, in the case of revision, the year of last revision. A number in parentheses indicates the year of last approval. A superscript epsilon (ϵ) indicates an editorial change since the last revision or reapproval.

This standard has been approved for use by agencies of the Department of Defense.

1. Scope

1.1 This practice covers techniques for the ultrasonic A-scan examination of specific weld configurations joining wrought ferrous or aluminum alloy materials to detect weld discontinuities (Note 1). The reflection method using pulsed waves is specified. Manual techniques are described employing contact of the search unit through a couplant film or water column.

1.2 This practice utilizes angle beams or straight beams, or both, depending upon the specific weld configurations. Practices for special geometries such as fillet welds and spot welds are not included. The practice is intended to be used on thicknesses of 0.250 to 8 in. [6.4 to 203 mm].

NOTE 1—This practice is based on experience with ferrous and aluminum alloys. Other metallic materials can be examined using this practice provided reference standards can be developed that demonstrate that the particular material and weld can be successfully penetrated by an ultrasonic beam.

NOTE 2—For additional pertinent information see Practice E 317, Terminology E 1316, and Practice E 587.

1.3 Values stated in inch-pound units are to be regarded as the standard. SI units are given for information only.

1.4 *This standard does not purport to address all of the safety concerns, if any, associated with its use. It is the responsibility of the user of this standard to establish appropriate safety and health practices and determine the applicability of regulatory limitations prior to use.*

2. Referenced Documents

2.1 ASTM Standards:

- E 317 Practice for Evaluating Performance Characteristics of Ultrasonic Pulse-Echo Examination Systems Without the Use of Electronic Measurement Instruments²
- E 543 Practice for Agencies Performing Nondestructive Testing²
- E 587 Practice for Ultrasonic Angle-Beam Examination by the Contact Method²

E 1316 Terminology for Nondestructive Examinations²

2.2 ASNT Standard:

Practice SNT-TC-1A Personnel Qualification and Certification in Nondestructive Testing³

2.3 ISO Standard:

ISO 2400 Reference Block for the Calibration of Equipment for Ultrasonic Examination⁴

3. Significance and Use

3.1 The techniques for ultrasonic examination of welds described in this practice are intended to provide a means of weld examination for both internal and surface discontinuities within the weld and the heat-affected zone. The practice is limited to the examination of specific weld geometries in wrought or forged material.

3.2 The techniques provide a practical method of weld examination for internal and surface discontinuities and are well suited to the task of in-process quality control. The practice is especially suited to the detection of discontinuities that present planar surfaces perpendicular to the sound beam. Other nondestructive tests may be used when porosity and slag inclusions must be critically evaluated.

3.3 When ultrasonic examination is used as a basis of acceptance of welds, there should be agreement between the manufacturer and the purchaser as to the specific reference standards and limits to be used. Examples of reference standards are given in Section 6. A detailed procedure for weld examination describing allowable discontinuity limits should be written and agreed upon.

3.4 *Personnel Qualification*—In order to meet the intent of this recommended practice, it is essential that evaluation be performed by properly trained and qualified testing personnel. The user is referred to Practice SNT-TC-1A published by American Society of Nondestructive Testing (ASNT) or other equivalent programs.

3.5 *Nondestructive Testing Agency Evaluation*—Use of an NDT agency (as defined in Practice E 543) to perform the examination may be agreed upon by the using parties. If a

¹ This practice is under the jurisdiction of ASTM Committee E07 on Nondestructive Testing and is the direct responsibility of Subcommittee E07.06 on Ultrasonic Method.

Current edition approved August 10, 2003. Published October 2003. Originally approved in 1960. Last previous edition approved in 1997 as E 164 - 97.

² *Annual Book of ASTM Standards*, Vol 03.03.

³ Available from The American Society for Nondestructive Testing (ASNT), P.O. Box 28518, 1711 Arlingate Ln., Columbus, OH 43228-0518.

⁴ Available from American National Standards Institute (ANSI), 25 W. 43rd St., 4th Floor, New York, NY 10036.

systematic assessment of the capability of the agency is specified, a documented procedure such as Practice E 543 shall be used as the basis for evaluation.

4. Search Units

4.1 Angle-Beam requirements for angle-beam search units are determined by the test variables. The examination procedure should be established by taking into consideration variables such as weld thickness, available surface, maximum allowable flaw size, flaw orientation, and the acoustic properties of the material. Consideration should also be given to the desirability of using comparable wave lengths within the materials where both a longitudinal-wave examination and an angle-beam shear-wave examination are employed. This can be accomplished by conducting the straight-beam (longitudinal-wave) examination at approximately two times the frequency of the angle-beam (shear-wave) examination.

4.2 Frequencies of 1.0 to 5 MHz are generally employed for angle-beam (shear-wave) and for straight-beam (longitudinal-wave) examination.

4.3 Transducer sizes recommended for weld examination range from a minimum of ¼-in. [6.4-mm] diameter or ¼-in. square to 1 in. [25.4 mm] square or 1½-in. [28.6-mm] diameter.

5. Standardization

5.1 Two methods of angle-beam standardization are in general use: the polar, and the rectangular, coordinate methods.

5.1.1 The polar coordinate method requires measurements of the beam centerline at the search unit/work interface and the beam angle in a test block, and the instrument sweep is calibrated along the beam line. Test information is graphically converted into position and depth coordinates for reflector location. The polar method is detailed in Annex A1.

5.1.2 The rectangular coordinate method requires measurement of the position of the reflector from the front of the search unit, and the instrument sweep is calibrated for depth to the reflector as it is moved to different positions in the beam providing a distance-amplitude curve. Test information is read directly for position and depth to the reflector. The rectangular coordinate method is detailed in Annex A2.

6. Reference Standards

6.1 IIW-type reference blocks are a class of reference blocks for checking and calibrating ultrasonic instrumentation, which meet the basic geometrical configuration described in ISO 2400 but which may deviate in such aspects as non-metric dimensioning, alternate materials, additional reflectors, and differences of scale details. IIW-type blocks are primarily intended for characterizing and calibrating angle-beam systems, but also provide features for such uses as straight-beam resolution and sensitivity checks.

NOTE 3—Discussion of the differences among various versions of “IIW-Type” reference blocks, illustrations of typical configurations and an extensive bibliography can be found in a published reference.⁵

⁵ Hotchkiss, F.H.C., “Guide to designs of IIW-type blocks”, *NDT International*, Vol. 23, n. 6, December 1990, pp. 319-331.

6.1.1 Only blocks fully meeting all the requirements of ISO 2400 should be referred to as IIW reference blocks.

6.1.2 Blocks qualified to certain other national standards may also satisfy all the requirements of ISO 2400 but have additional features.

6.1.3 The term *IIW Block Type I* should be used only to describe blocks meeting the standard cited. The term *IIW Block Type II* is reserved for the miniature angle-beam block recognized by ISO.

6.1.4 All other blocks derived from the basic ISO 2400 configuration, but not fully meeting all its requirements should be referred to as *IIW-Type* blocks.

6.1.5 Suppliers and users of such blocks should identify the specifications which are met, or provide detailed documentation.

6.1.6 Because of the possible differences noted, not all IIW-type blocks may be suited for every application for which qualified ISO 2400 blocks may be acceptable.

6.1.7 Unless the blocks have also been checked by prescribed ultrasonic procedures, they may also produce non-uniform or misleading results.

6.2 Distance Standardization:

6.2.1 An equal-radius reflecting surface subtending an arc of 90° is recommended for distance standardization because it is equally responsive to all beam angles. Other reflector configurations may be used. Equal-radius reflecting surfaces are incorporated into IIW-Type Blocks and several other reference blocks (see Annex A1) (Note 3). Distance standardization on a square-notch corner reflector with a depth of 1 to 3 % of thickness may be used. However, full beam reflections from the square corner of the block will produce erroneous results when standardizing angle beams near 60°, due to mode conversion. The square corner of the block should not be used for distance standardization.

NOTE 4—Small errors of beam index location are indigenous to the standardization procedure using the an IIW-Type Block. Where extremely accurate standardization is necessary, a procedure such as that outlined in 6.2.2 should be used.

6.2.2 For examination of welds, a side-drilled hole may be used for distance, amplitude, position, and depth standardization. An example is shown in Fig. 1. Move the reflector through the beam to 1/8, 3/8, 5/8, 7/8, and 9/8 of the Vee path. Adjust the delay to place indication 1 at sweep division 1. Adjust the

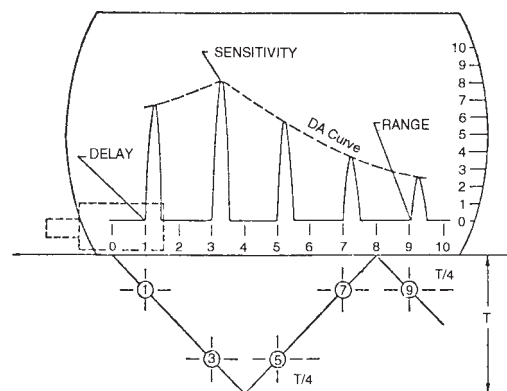

FIG. 1 Side-Drilled Hole

range to place indication 9 at sweep division 9. Since these controls interact, repeat the delay and range adjustments until indications 1 and 9 are placed at sweep divisions 1 and 9. Adjust sensitivity to provide an 80 %-of-full-screen indication from the highest of the 1, 3, 5, 7, or 9 indications. At this sensitivity, mark the maximum amplitudes on the screen from the reflector at 1, 3, 5, 7, and 9. Connect these points for the distance amplitude curve (DA Curve). Corner reflections from the hole to the surface may be observed at 4 and 8 divisions on the sweep; these indications will not be used in the DA Curve. Measure the position of the reflector on the surface from the front of the search unit to the surface projection of the hole centerline. Since the depth to the hole is known, the standardization provides means for estimating the position, depth, and relative size of an unknown reflector.

6.3 Sensitivity-Amplitude Standardization:

6.3.1 Reference standards for sensitivity-amplitude standardization should be designed so that sensitivity does not vary with beam angle when angle-beam examination is used. Sensitivity-amplitude reference standards that accomplish this end are side-drilled holes parallel to the major surfaces of the plate and perpendicular to the sound path, flat-bottomed holes drilled at the examination angle, and equal-radius reflectors. Surface notches can also accomplish this end under some circumstances. These reference reflectors are described in Table 1.

6.3.2 Under certain circumstances, sensitivity-amplitude standardization must be corrected for coupling variations (Section 7) and distance amplitude effects (Section 8).

7. Coupling Conditions

7.1 Preparation:

7.1.1 Where accessible, prepare the surface of the deposited weld metal so that it merges into the surfaces of the adjacent base materials; however, the weld may be examined in the as-welded condition, provided the surface condition does not interfere with valid interpretation of indications.

7.1.2 Free the scanning surfaces on the base material of weld spatter, scale, dirt, rust, and any extreme roughness on each side of the weld for a distance equal to several times the thickness of the production material, this distance to be governed by the size of the search unit and refracted angle of the sound beam. Where scanning is to be performed along the top or across this weld, the weld reinforcement may be ground to provide a flat scanning surface. It is important to produce a surface that is as flat as possible. Generally, the surfaces do not require polishing; light sanding with a disk or belt sander will usually provide a satisfactory surface for examination.

7.1.3 The area of the base material through which the sound will travel in the angle-beam examination should be completely scanned with a straight-beam search unit to detect reflectors that might affect the interpretation of angle-beam results by obstructing the sound beam. Consideration must be given to these reflectors during interpretation of weld examination results, but their detection is not necessarily a basis for rejection of the base material.

7.2 Couplant:

7.2.1 A couplant, usually a liquid or semi-liquid, is required between the face of the search unit and the surface to permit transmission of the acoustic energy from the search unit to the material under examination. The couplant should wet the surfaces of the search unit and the piece, and eliminate any air space between the two. Typical couplants include water, oil, grease, glycerin, and cellulose gum. The couplant used should not be injurious to the material to be examined, should form a thin film, and, with the exception of water, should be used sparingly. When glycerin is used, a small amount of wetting agent is often added to improve the coupling properties. When water is used, it should be clean and de-aerated if possible. Inhibitors or wetting agents, or both, may be used.

7.2.2 The coupling medium should be selected so that its viscosity is appropriate for the surface finish of the material to be examined. The following table is presented as a guide:

Roughness Average (Ra μ in.)	Equivalent Couplant Viscosity
5 to 100	SAE 10 wt. motor oil
50 to 200	SAE 20 wt. motor oil
80 to 600	glycerin
100 to 400	SAE 30 wt. motor oil

7.2.3 In performing the examination, it is important that the same couplant, at the same temperature, be used for comparing the responses between the standardization blocks and the production material. Attenuation in couplants and wedge materials varies with temperature so that a standardization performed in a comfortable room is not valid for examination of either hotter or colder materials.

8. Distance-Amplitude Correction

8.1 Use standardization blocks of similar surface finish, nominal thickness and metallurgically similar in terms of alloy and thermal treatment to the weldment.

8.2 Alternative techniques of correction may be used provided the results are as reliable as those obtained by the acceptable method. In addition, the alternative technique and its equipment shall meet all the performance requirements of this standard.

TABLE 1 Reference Reflectors and Their Attributes

Reference Reflector	Attributes and Limitations
Side-drilled holes	Easily manufactured and reproducible. Equally reflective to different beam angles. However, they bear negligible size relationship to most critical flaws.
Flat-bottom hole at examination angle	Difficult to manufacture and requires good angular agreement of drilled hole with examination angle.
Surface notches	Square notches simulate cracks at surface. V-notch half-angle should complement beam angle for maximum response.

8.3 Standardization Reflectors:

8.3.1 *Straight-Beam Standardization*—Correction for straight-beam examination may be determined by means of a side-drilled hole reflector at $\frac{1}{4}$ and $\frac{3}{4}$ of the thickness. For thickness less than 2 in. [51 mm], the $\frac{1}{4}$ -thickness reflector may not be resolved. If this is the case, drill another hole at $\frac{1}{2}$ thickness and use the $\frac{1}{2}$ and $\frac{3}{4}$ -thickness reflectors for correction.

8.3.2 *Angle-Beam Standardization*—Correction for angle-beam examination may be determined by means of side-drilled hole reflectors at $\frac{1}{4}$ and $\frac{3}{4}$ of the thickness. The $\frac{1}{2}$ -thickness depth to a side-drilled hole may be added to the standardization or used alone at thicknesses less than 1 in. [25.4 mm].

8.4 Acceptable Techniques:

8.4.1 *Distance-Amplitude Curve*—This method makes use of standardization blocks representing the minimum and maximum thickness to be examined. Additional standardization blocks of intermediate thicknesses can be used to obtain additional data points. The ultrasonic instrument, search unit, angle beam wedge, and couplant used for the distance-amplitude standardization must also be used for the weld examination.

8.4.1.1 Set the instrument to give an 80 % signal on the cathode ray screen from the highest amplitude obtained from the standardization reflectors. Test the other standardization reflectors with the same instrument settings, and either record or mark on the screen the percent of screen height of the indication.

8.4.1.2 Then use these recorded percentages to draw a distance-amplitude curve of percent screen height versus depth or thickness on a chart or on the screen. During examination the distance amplitude curve may be used to estimate indication amplitude in percent of the DA Curve.

8.4.2 *Electronic Distance Amplitude Correction*—This method can be used only if the instrument is provided with electronic distance amplitude compensation circuitry. Use is made of all reflectors in the standardization range. The equip-

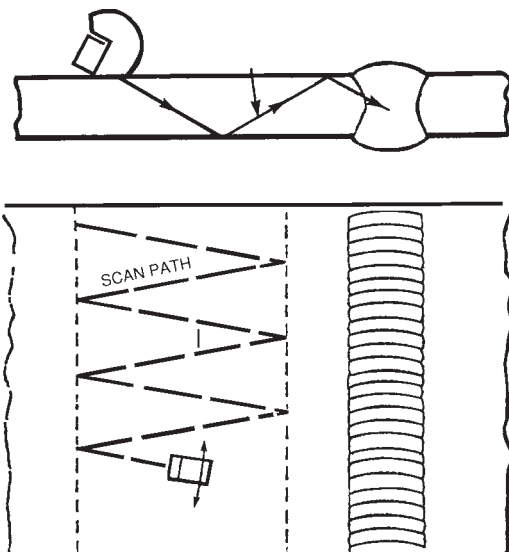

FIG. 2 Technique 1, for Examining Butt Welds with Angle Beams

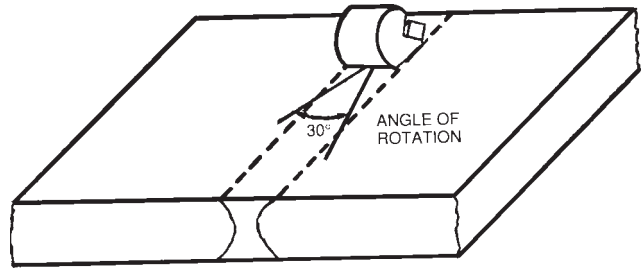

FIG. 3 Supplementary Technique 2, for Examining Butt Welds for Suspected Cross-Cracking when the Weld Bead is Ground Flush

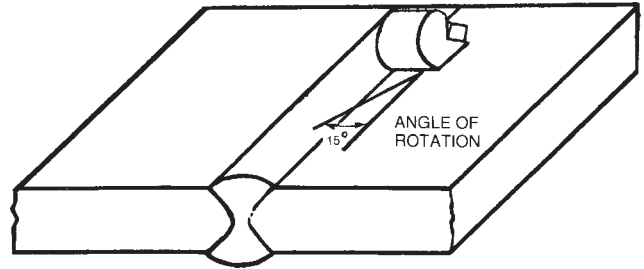

FIG. 4 Supplementary Technique 3, for Examining Butt Welds for Suspected Cross-Cracking when the Weld Bead is not Ground Flush

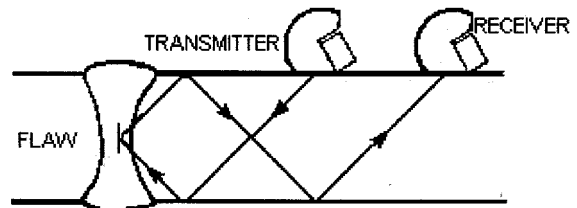

FIG. 5 Two-Search-Unit Technique 4, for Use with Thick Weldments

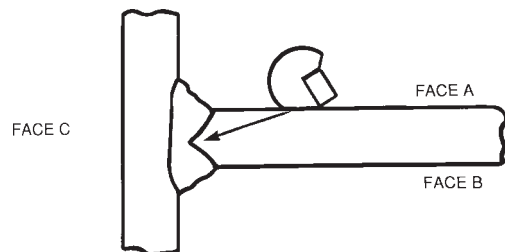

FIG. 6 Technique 5, for Examining the Weld Volume of T-Welds

ment, search unit, couplant, etc., to be used in the ultrasonic examination are to be used for this attenuation adjustment.

8.4.2.1 Set the instrument to give a 50 % amplitude on the cathode ray screen from the reference reflector that gives the highest amplitude.

8.4.2.2 Test each reflector at other distances with the same instrument settings, adjusting the electronic distance amplitude correction controls to establish a 50 % screen height from the reference reflector at each successive thickness. Means of accomplishing the equalization of amplitude from equal-size

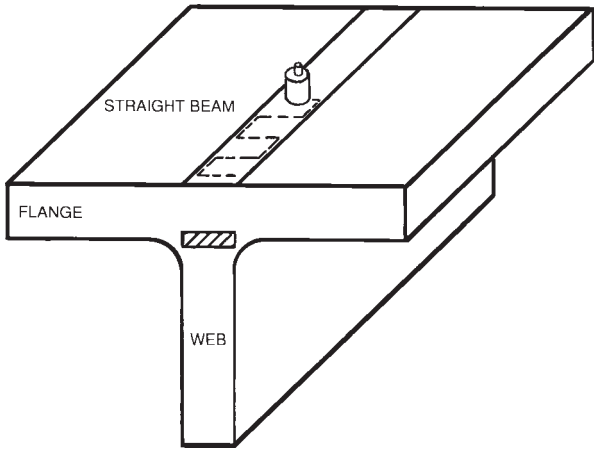

FIG. 7 Technique 6, for Examining the Fusion Zone of T-Welds

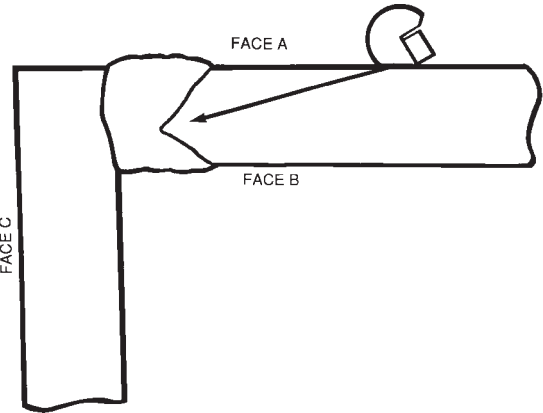
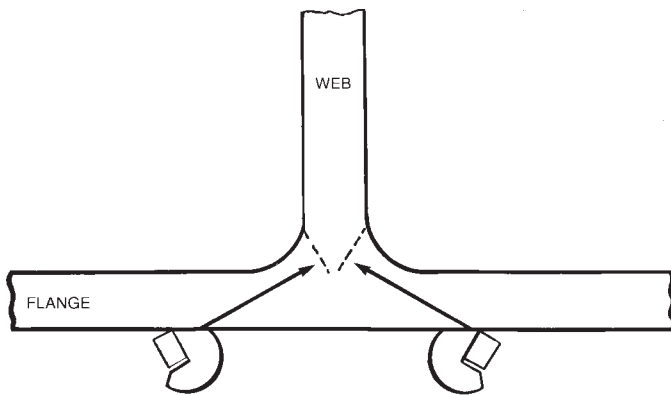

FIG. 9 Technique 8, for Examining the Weld Volume of Double-Vee Corner Welds



8(a) Technique 7, for Searching T-Welds for Discontinuities

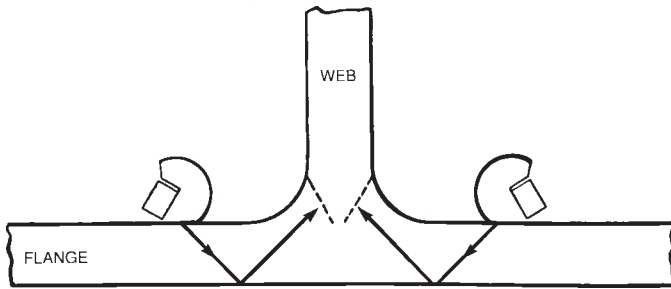

FIG. 8 (b) Alternative Technique 7, for Searching T-Welds for Discontinuities

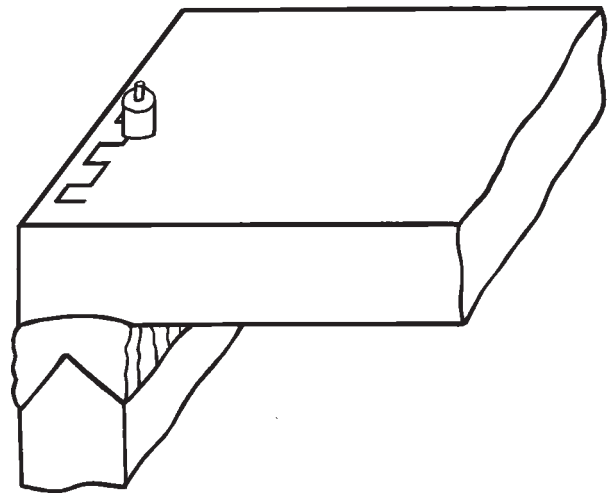

FIG. 10 Technique 9, for Examining the Fusion Zone of Double-Vee Corner Welds

reflectors over the distance range is best described for each instrument in the operating manual for that instrument.

9. Examination Procedures

9.1 Examination procedures recommended for common weld configurations are detailed in Table 2.

9.1.1 Special attention should be given to curved or contoured surfaces to ensure consistent ultrasonic beam entry angle and adequate coupling. Examine circumferential welds using Techniques 12 and 13 (Fig. 12 and Fig. 13); examine longitudinal welds using Techniques 14 and 15 (Fig. 14 and Fig. 15). Base choice of angle both on the radius of curvature

and the thickness of the material in order to provide a beam that will travel through the material and reflect from the opposite surface.

9.1.2 When more than one technique is given for a particular weld geometry or thickness or both, the first technique is considered primary, while the additional techniques are supplementary and may be added to the examination procedure.

10. Reflector Evaluation

10.1 *Reflector Location*—When distance standardization has been achieved in accordance with 6.1, approximate reflector location can be accomplished using the method of 6.1.2 or a chart of the type shown in Fig. 16.

10.2 *Reflector Size and Orientation:*

10.2.1 *Geometrical Methods*—Reflector length ¼ in. [6.4 mm] minimum can be measured by determining the points at which half (6 dB) of the amplitude is lost at the extremities of the reflector and measuring between them. Reflector height ⅓ in. [3.2 mm] minimum can be measured by determining Δ SR (the change in sweep reading) at which half (6 dB) of the amplitude is lost as the search unit is moved to and from the reflector. The Δ SR × 100 divided by tSR (through thickness sweep reading) approximates the reflector height in percent of

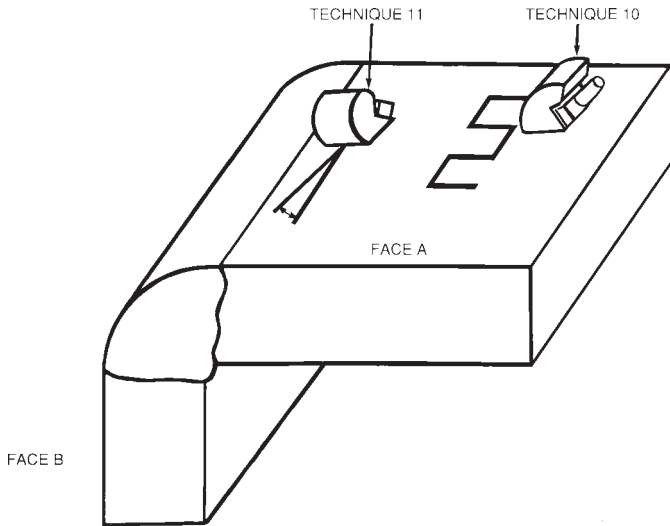

FIG. 11 Techniques 10 and 11, for Examining Full-Penetration Double-Fillet Corner Welds

thickness. Only the area of the reflector that reflects energy to the search unit is measured. See Fig. 17. This method is appropriate for reflectors with dimensions greater than the beam diameter. For reflectors smaller than the beam, significant errors may occur.

10.2.2 Amplitude Methods—Signal amplitude can be used as a measure of flaw severity. Amplitude evaluation should be based upon experience with actual flaws since artificially produced reflectors are not always directly relatable to real flaw shapes or sizes. For adversely oriented planar flaws, the amplitude may not indicate flaw severity.

10.3 Reflector Type—In addition to the evaluation of location and size of reflectors, there are several other attributes which can be used to identify other types of reflectors. It must be emphasized that these methods are dependent on operator skill to such a degree that acceptance of welds based upon this type of information alone is not recommended.

10.3.1 Reflector Orientation—Reflector orientation can be deduced from relative signal amplitudes obtained from the reflector with the search unit placed at various locations on the weldment. An example is shown in Fig. 18.

10.3.2 Reflector Shape—Reflector shape and roughness will result in a characteristic degree of sharpness of the CRT trace deflection depending upon the nature of the flaw, the instrument, and search-unit combination used.

11. Report

11.1 The contracting parties should determine the pertinent items to be recorded. This may include the following information:

11.1.1 Weld types and configurations tested, including thickness dimensions. Descriptive sketches are usually recommended.

11.1.2 Automatic flaw alarm or recording equipment or both, if used.

11.1.3 Special search units, wedges, shoes, or saddles, if used.

11.1.4 Rotating, revolving scanning mechanisms, if used.

11.1.5 Stage of manufacture at which examination was made.

11.1.6 Surface or surfaces from which the examination was performed.

11.1.7 Surface finish.

11.1.8 Couplant.

11.1.9 Method used.

11.1.10 Technique used.

11.1.11 Description of the standardization method and method of correlating indications with flaws.

11.1.12 Scanning parameters such as raster pitch and direction of beam.

11.1.13 Mode of transmission including longitudinal or shear, pulse-echo, tandem or through transmission.

11.1.14 Type and size of transducer.

11.1.15 Examination frequency.

11.1.16 Instrument identification information.

11.1.17 Flaw description (depth, location, length, height, amplitude, and character).

11.1.18 Name of operator.

11.1.19 Date of examination.

12. Keywords

12.1 NDT of weldments; nondestructive testing; ultrasonic contact examination; ultrasonic NDT of weldments; weldments

TABLE 2 Procedures Recommended for Common Weld Configurations

Weld Type	Weld Throat Thickness									
	Less than ½ in. [12 mm]		½ to 1½ in. [12 to 38 mm]		1½ to 2½ in. [38 to 63 mm]		2½ to 5 in. [63 to 127 mm]		5 to 8 in. [127 to 200 mm]	
	Primary	Top ¼	Primary	Top ¼	Primary	Top ¼	Primary	Top ¼	Primary	Top ¼
<i>Butt:</i>										
Recommended angle, deg	70	70	70 or 60	45 or 60	70, 60, or 45	45 or 60	60 or 45	45 or 60	60 or 45	45
Suggested technique ^A	1, (2 or 3)	1	1, (2 or 3)	1	1, (2 or 3)	1	1, (2 or 3), 4	1	1, (2 or 3), 4	1
<i>Tee:</i>										
<i>Face A^B:</i>										
Recommended angle, deg	70		70 or 60		70, 60, or 45		60 or 45		45	
Suggested technique	5		5		5		5, 4		5, 4	
<i>Face B^B:</i>										
Recommended angle, deg	70		70 or 60		70, 60, or 45		60 or 45		45	
Suggested technique	5		5		5		5, 4		5, 4	
<i>Face C^B:</i>										
Recommended angle, deg	straight, 70		straight (70 or 45)		straight, 45		straight, 45		straight, 45	
Suggested technique	6, 7		6, 7		6, 7		6, 7		6, 7	
<i>Corner:</i>										
<i>Face A^C:</i>										
Recommended angle, deg	70		70 or 60		70, 60, or 45		60 or 45		45	
Suggested technique	8		8		8		8		8	
<i>Face B^C:</i>										
Recommended angle, deg	70		70 or 60		70, 60, or 45		60 or 45		45	
Suggested technique	8		8		8		8		8	
<i>Face C^C:</i>										
Recommended angle, deg	straight		straight		straight		straight		straight	
Suggested technique	9		9		9		9		9	
<i>Double Fillet Corner Weld:</i>										
<i>Face A^D:</i>										
Recommended angle, deg	45		45		45		45		45	
Suggested technique	10, 11		10, 11		10, 11		10, 11		10, 11	
<i>Face B^D:</i>										
Recommended angle, deg	45		45		45		45		45	
Suggested technique	10,11		10, 11		10, 11		10, 11		10, 11	

^A See Figs. Figs. 2-11 for illustration of the techniques listed below.

^B Faces A, B, and C for tee welds are shown in Fig. 6.

^C Faces A, B, and C for corner welds are shown in Fig. 9.

^D Faces A and B for double fillet corner welds are shown in Fig. 11.

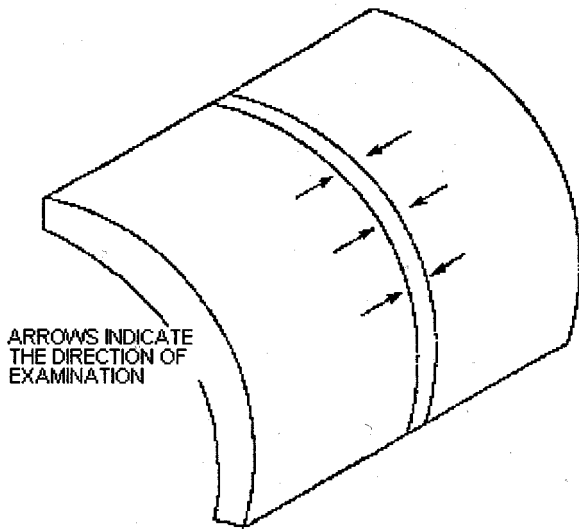

NOTE 1—Search-unit shoes are machined to match the curvature of the work piece when diameter is less than 20 in. [500 mm].

FIG. 12 Technique 12, for Examining Circumferential Welds

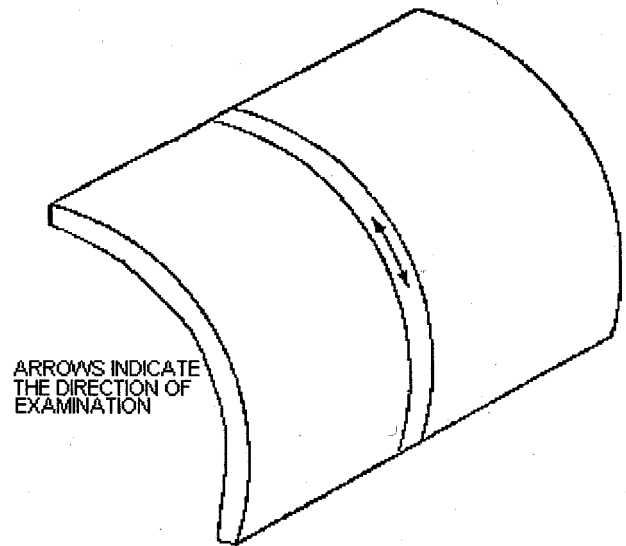

NOTE 1—Search-unit shoes are machined to match the curvature of the work piece when diameter is less than 20 in. [500 mm].

FIG. 13 Supplementary Technique 13, for Examining Circumferential Welds, for Welds Ground Flush

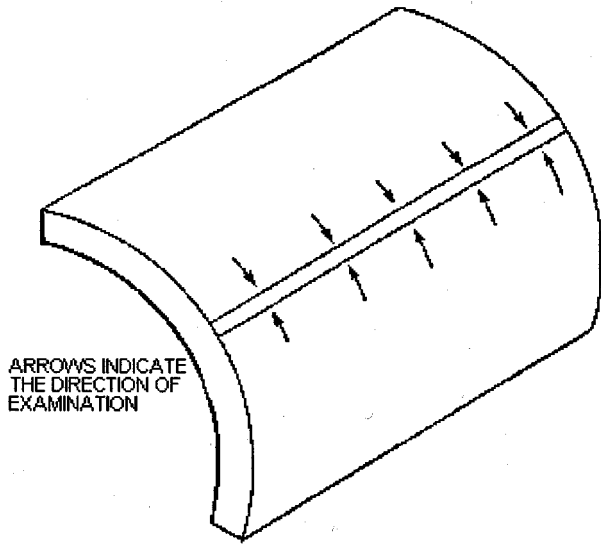

NOTE 1—Search-unit shoes are machined to match the curvature of the work piece when diameter is less than 20 in. [500 mm].

FIG. 14 Technique 14, for Examining Longitudinal Welds

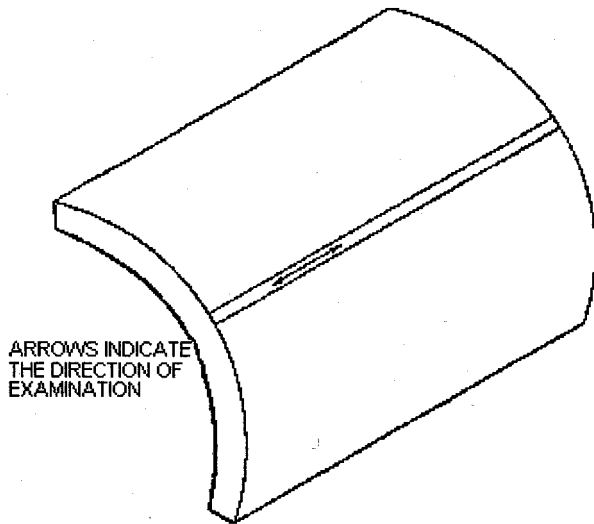

NOTE 1—Search-unit shoes are machined to match the curvature of the work piece when diameter is less than 20 in. [500 mm].

FIG. 15 Supplementary Technique 15, for Examining Longitudinal Welds, for Welds Ground Flush

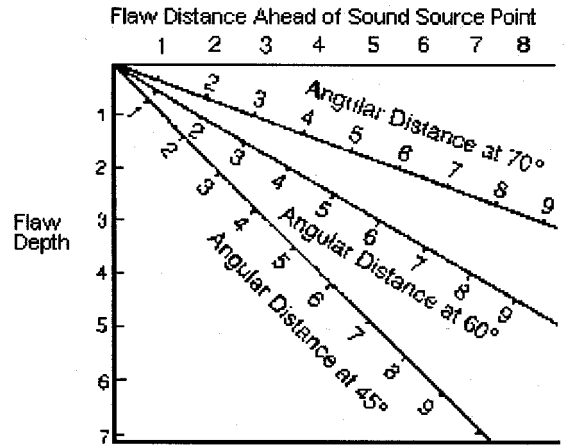

FIG. 16 Flaw Location Chart

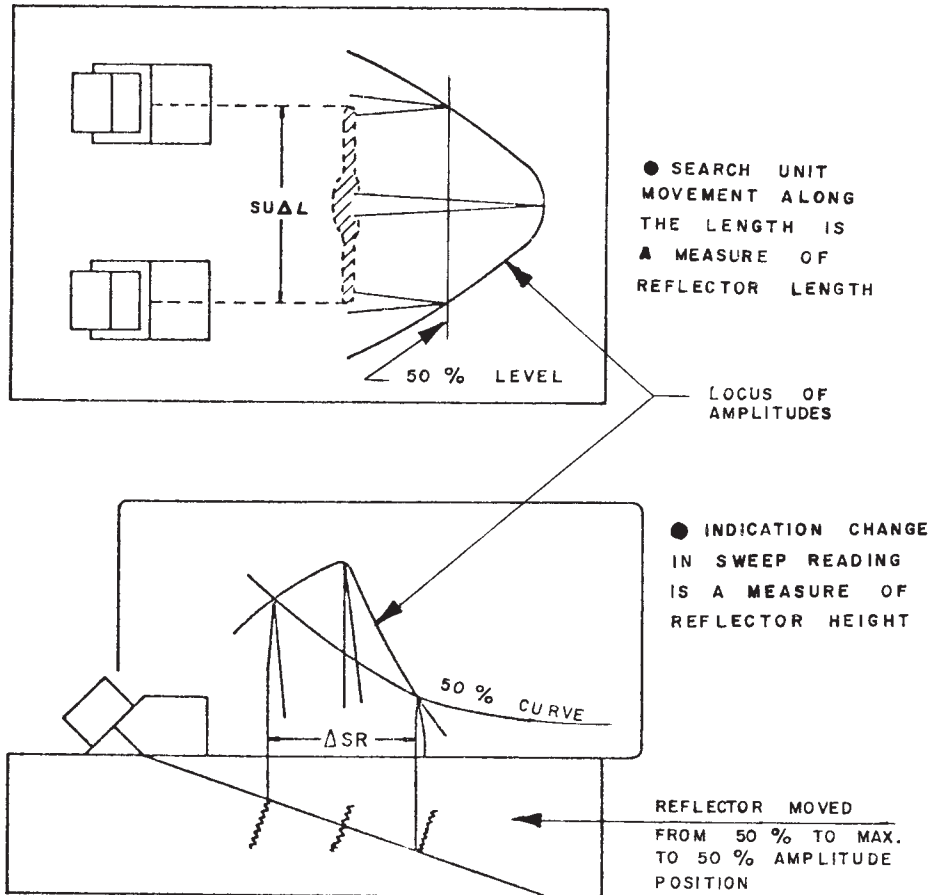
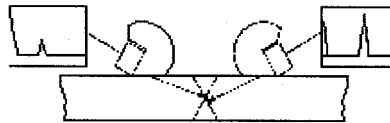

FIG. 17 Reflector Size Evaluation



Examination from both sides of weld reveals flaw orientation.

FIG. 18 Determination of Reflector Orientation

ANNEXES

(Mandatory Information)

A1. INSTRUCTIONS FOR USE OF INTERNATIONAL INSTITUTE OF WELDING (IIW) TYPE REFERENCE BLOCKS AND OTHER REFERENCE BLOCKS FOR ULTRASONIC TESTING

A1.1 Purpose

A1.1.1 *IIW Type Reference Blocks*—To facilitate the adjustment and standardization of ultrasonic flaw-detecting equipment. The blocks can also be used to:

- A1.1.1.1 Calibrate the sweep length,
- A1.1.1.2 Adjust the pulse energy and amplification,

A1.1.1.3 Confirm the stability and proper operation of the equipment, or

A1.1.1.4 Determine probe characteristics, such as their sensitivity, and in the case of angle-beam search units, the location of the beam exit point (beam index), the path length in the wedge, and the angle of refraction.

A1.1.2 *Supplementary Blocks*—Blocks other than those derived from the IIW Reference Block 1, can be used for distance and sensitivity standardization. For details, see A1.5.

A1.2 Description

A1.2.1 The recommended configuration for an IIW-Type reference block for use in this practice is shown in Fig. A1.1. Dimensions are given for a version in U.S. customary units, and for a metric version based on IIW, ISO, and some national standards. Material must be selected by the using parties. Unless otherwise specified, a low carbon-steel such as UNS G10180 is suggested. An optional cylindrical acrylic plastic disk may be permanently mounted in the 2 in. [50 mm] diameter hole; it is not required for this practice.

NOTE A1.1—If the disk is provided it shall meet these requirements:
 material—polymethylmethacrylate resin
 thickness— 0.920 ± 0.005 in. [23 ± 0.1 mm]
 surfaces—polished, flat within 0.002 in. [0.5 mm]
 one surface to be mounted flush with a block face

A1.3 Distance Standardization

A1.3.1 *Straight-Beam Longitudinal Wave:*

A1.3.1.1 When standardizing the horizontal distance or sweep-length scale, adjust the multiple echoes obtained from a known length of the reference block in such a way that the leading edges of the echoes (the left-hand side) coincide with the required divisions of the horizontal scale. In most instances, utilization of the highest possible frequency is recommended to produce sharp indications, thereby improving the accuracy of the distance standardization.

A1.3.1.2 As previously mentioned, the standardization is only valid if the materials to be examined are fabricated from a material with the same or approximately the same velocity of sound as the reference block; for instance, a carbon steel reference block should not be used when examining certain stainless steels. Furthermore, it should be realized that the initial pulse indication may not be a true representation of the entrant surface. When using the double search unit technique, it should be realized that the distances between the multiple echoes are not completely equal because of the different path lengths, which are inherent to this technique. When using the double search unit technique combined with another medium between probe and specimen, an even larger distance between the initial pulse indication and the first echo, compared to the distance between the multiple echoes, will be observed. The two screen images for a 4-in. [100-mm] range setting, obtained when using the single search unit and the double search unit techniques are illustrated in Fig. A1.2.

A1.3.1.3 *Single Search Unit Technique*—To standardize the sweep length when using a straight-beam longitudinal-wave search unit for a distance less than 10 in. [250 mm], place the search unit as indicated in Fig. A1.3 and adjust the distance between the multiple echoes to 4 in. [100 mm]. To calibrate the sweep length when using a straight-beam longitudinal wave search unit for a distance greater than 10 in. [250 mm], place the search unit in the position indicated in Fig. A1.3. For the 20-in. [500-mm] range, a screen pattern will appear as shown in Fig. A1.4. This screen pattern also shows the indications

caused by shear waves generated by the mode conversion of the longitudinal waves and other reflections.

A1.3.2 *Using an Angle-Beam Search Unit for a Sweep Length from 4 to 10 in. [100 to 250 mm]:*

A1.3.2.1 Place the search unit in the position indicated in Fig. A1.5 and use the echoes obtained from the curved surface (with a radius of 4 in. [100 mm] and the groove with a radius of 1 in. [25 mm]. The sweep-length setting most commonly used is 10 in. [250 mm], whereby the screen pattern must be standardized in such a way that the indication of the curved surface appears at 4 in. and the pulse indication of the groove appears at 9 in. [225 mm]. The indication from the curved surface will be at its maximum amplitude when the beam index coincides with the center point of the curvature; verify this by moving the search unit back and forth, parallel to the sides of the reference block. In this case, the groove echo can be received by slightly rotating the search unit. In most instances, the initial pulse indication will appear to the left of the scale zeropoint, caused by the delay in the wedge.

A1.3.2.2 It is also possible to standardize the time base for shear waves for any material whose shear to longitudinal velocity ratio is 0.55 by placing a straight-beam longitudinal-wave search unit in the position indicated in Fig. A1.6. The multiple echoes obtained in this way will appear at distances that coincide with a sound path of 2 in. [50 mm] for shear waves. If the sweep length is standardized in this manner, it is essential that subsequently the zeropoint be corrected if angle-beam search units are used, because of the time delay caused by the wedge. The above method can be used, for example, for standardizing a distance of 4 in. [100 mm], whereby the two multiple echoes obtained from the 3.64-in. [91-mm] distance are positioned at respectively 2 in. [50 mm] and 4 in. [100 mm] on the scale. After the angle beam shear wave search unit has been connected, correct the zeropoint by adjusting the sweep-delay control to position echo from 4-in. [100-mm] radius reflector, at position of second back reflections of the straight beam.

A1.3.3 *Using an Angle-Beam Search Unit for a Sweep Length Larger than 10 in. [250 mm]*—The same method can be used as described in A1.3.2; position a straight-beam longitudinal-wave search unit as illustrated in Fig. A1.6 and thereafter correct the zeropoint in a manner similar to A1.3.2.2.

A1.3.4 *Distance Standardization for the Sound Path, Projected on the Surface to be Scanned*—Place the search unit on the reference block as indicated in Fig. A1.7 and correct the signal obtained from the edge of the block to coincide with the distance between the beam index and the edge of the block. A standard ruler may be used to measure the skip distances. For inch-dimensioned blocks, the ruler should be a minimum of 12 in. long with 0.1-in. or smaller divisions; for SI unit blocks, the ruler should be a minimum of 300 mm long with 2-mm or smaller divisions. Make adjustments for the skip distance and half of the skip distance. It should be noted that when utilizing angle-beam search units of approximately 60° , this standardization may be erroneous due to mode conversion.

A1.3.5 *Adjustment of Sensitivity*—When adjusting the sensitivity, take into consideration the following points:

A1.3.5.1 The frequency used.

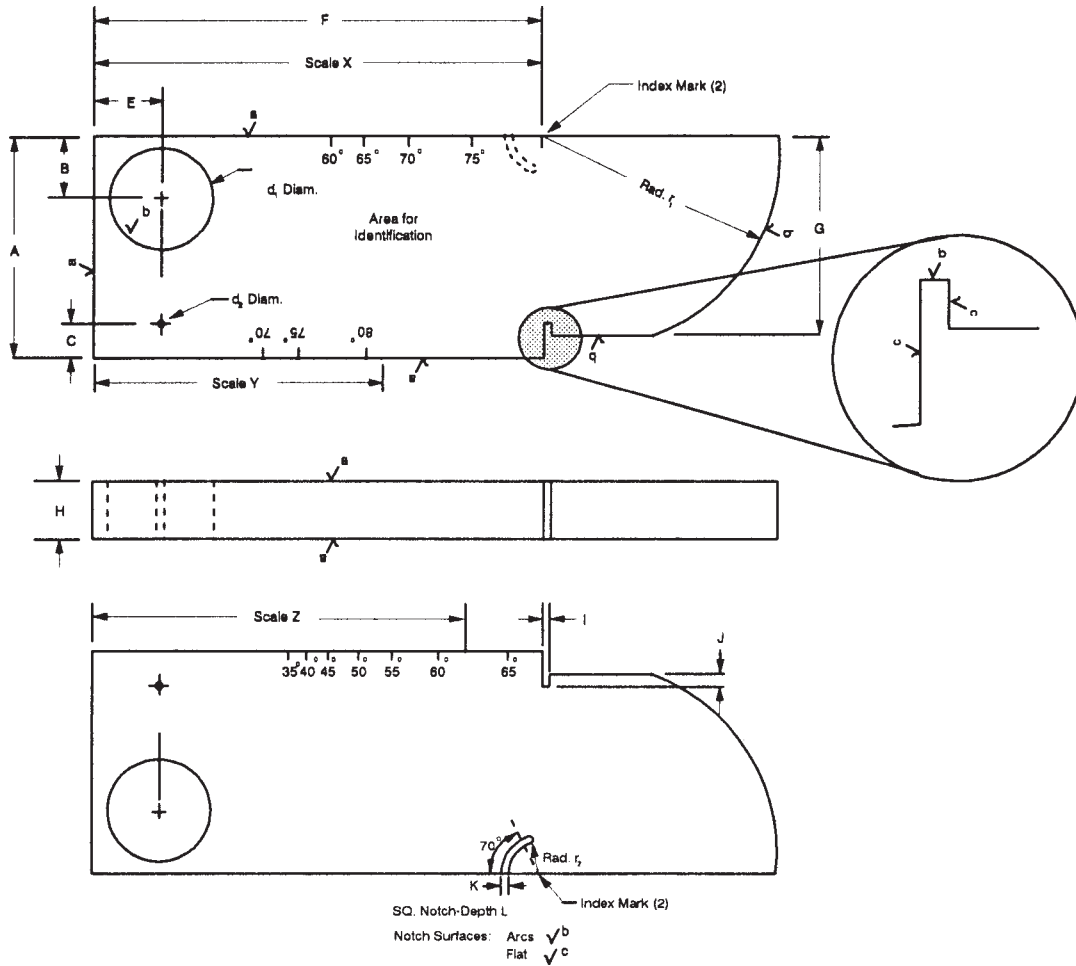

Table of Dimensions

Symbol	U.S. Customary Block		Metric Block	
	Dimension (in.)	Tolerance (in.)	Dimension (mm)	Tolerance (mm)
A	4.000	0.005	100	0.1
B	1.200	0.005	30	0.1
C	0.600	0.005	15	0.1
d ₁	2.000	0.01	50	0.2
d ₂	0.060	0.001	1.5	0.02
E	1.400	0.005	35	0.1
F	8.000	0.005	200	0.1
G	3.640	0.005	91	0.1
H	1.000	0.005	25	0.1
I	0.080	0.005	2	0.1
J	0.240	0.005	6	0.1
K	0.120	0.005	3	0.1
L	0.060	0.005	1.5	0.1
r ₁	4.000	0.01	100	0.2
r ₂	1.000	0.01	25	0.2
Surfaces/finish R _a	a		32 μin. max	0.8 μm max
	b		63 μin. max	1.6 μm max
	c		125 μin. max	3.2 μm max
		<u>Scales</u>		
X	1.200 tan α + 1.400	0.005	30 tan α + 35	0.1
Y	0.600 tan β + 1.400	0.005	15 tan β + 35	0.1
Z	2.800 tan γ + 1.400	0.005	70 tan γ + 35	0.1

NOTE 1—Material as specified.

Note 2—Scale X is 60°–75°, 1° increments, legends at 60°, 65°, 70°, & 75°.

Note 3—Scale Y is 70°–80°, 1° increments, legends at 70°, 75°, & 80°.

Note 4—Scale Z is 35°–65°, 1° increments, legends at 35°, 40°, 45°, 50°, 55°, 60° & 65°.

Note 5—In order to avoid sharp edges, minimize plating buildup, or remove in-service nicks and burrs, block edges may be smoothed by beveling or rounding, provided the corner treatment does not reduce the edge dimension by more than 0.020 in. [0.5 mm].

Note 6—English and metric units shown on this figure represent values used for two different blocks, that is, U.S. Customary Block and a Metric Block, and are not necessarily equivalent values.

FIG. A1.1 Reference Blocks for Ultrasonic Testing

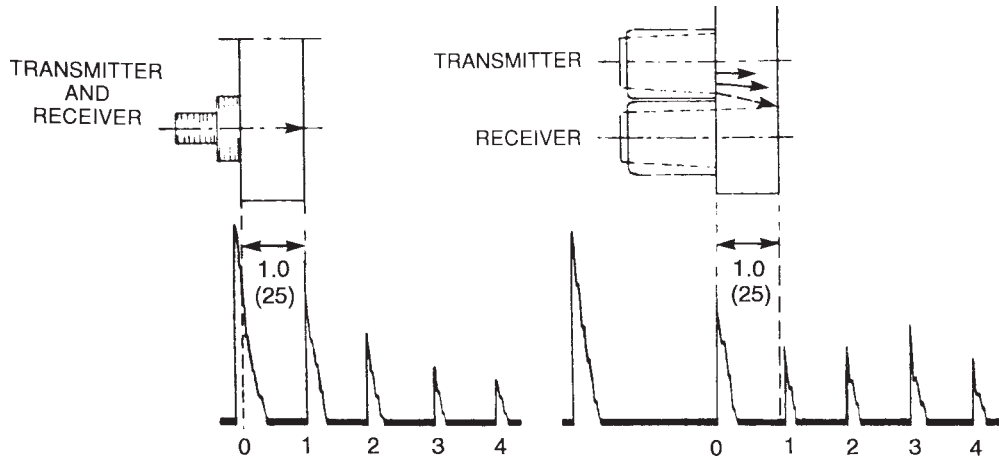

NOTE 1—English and metric units shown on this figure represent values used for two different blocks, that is, U.S. Customary Block and a Metric Block, and are not necessarily equivalent values.

FIG. A1.2 Screen Images for a 4-in. [100-mm] Range Setting

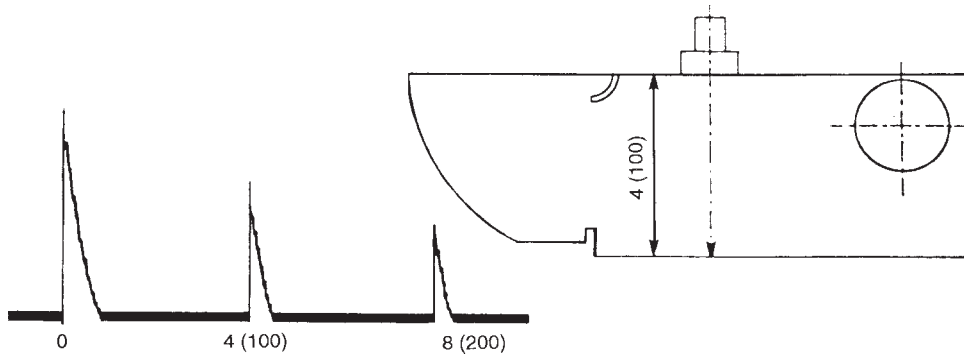

NOTE 1—English and metric units shown on this figure represent values used for two different blocks, that is, U.S. Customary Block and a Metric Block, and are not necessarily equivalent values.

FIG. A1.3 Position for a Single Straight-Beam Longitudinal Wave Search Unit

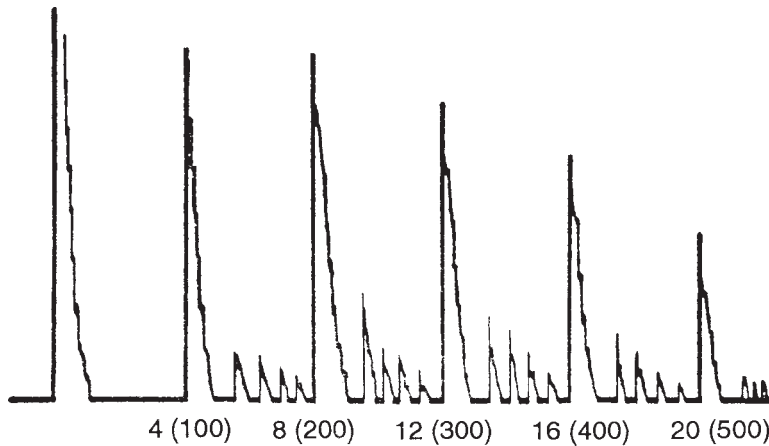

NOTE 1—English and metric units shown on this figure represent values used for two different blocks, that is, U.S. Customary Block and a Metric Block, and are not necessarily equivalent values.

FIG. A1.4 Screen Pattern Showing Indications Caused by Mode Conversion

A1.3.5.2 The energy of the transmitted pulse.

A1.3.5.4 The attenuation of the material to be examined,

A1.3.5.3 The surface condition of the object to be examined.

relative to its acoustical characteristics.

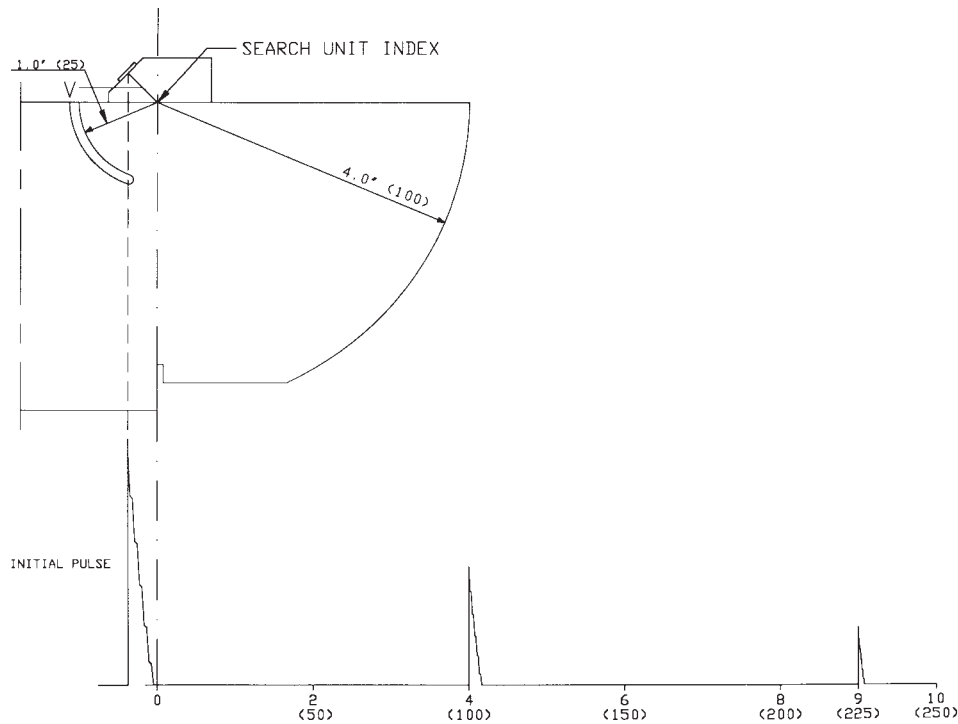

NOTE 1—English and metric units shown on this figure represent values used for two different blocks, that is, U.S. Customary Block and a Metric Block, and are not necessarily equivalent values.

FIG. A1.5 Position for an Angle-Beam Search Unit

A1.3.5.5 The characteristics of the reflecting flaw, distance, surface condition, orientation, and the type of discontinuity.

A1.4 Checking the Search Units and Their Characteristics

A1.4.1 When checking the characteristics of a search unit, contact between the specimen and search unit is of major importance, and it is necessary to use sufficient couplant. If various search units are to be compared, the same couplant should be used for each test.

A1.4.1.1 *Determination of the Beam Index of Angle-Beam Search Units*—Position the search unit as indicated in Fig. A1.5 and move it parallel to the sides of the reference block until the maximum echo from the quadrant is obtained. The beam index is now directly above the centerpoint of the quadrant.

A1.4.1.2 *Determination of the Sound Path in the Wedge*—The method mentioned in A1.4.1.1 makes a direct measurement of the sound path in the wedge possible. It is known that the echo on the screen is caused by a reflection from a plane lying at a distance of 4 in. [102 mm]. The additional distance that is read on the screen is caused by the delay in the wedge. Normally, this sound path is not taken into consideration and the initial pulse indication is moved in such a way that the quadrant echo corresponds with the 4-in. line on the screen (with long delay wedges this initial pulse indication is sometimes completely off the screen).

A1.4.1.3 *Determination of the Angle of Refraction*—The echo, which reflects from the surface of the 2-in. [50-mm]

diameter hole, is used. The reference that is engraved on both sides of the block makes a direct determination of angles between 35 and 75° possible. The exact angle of refraction can be read at the beam index when the echo is at its maximum height. When measuring angles of refraction between 75 and 80°, the small hole 0.060 in. [1.5 mm] is used. Both positions are indicated in Fig. A1.8.

A1.5 Standardization with Supplementary Blocks

A1.5.1 Other types of reference blocks are illustrated in the following figures:

Fig. A1.9—Type DC Distance Reference Block

Fig. A1.10—Type SC Sensitivity Reference Block

Fig. A1.11—Type DSC Distance and Sensitivity Reference Block

Fig. A1.12—Type MAB Miniature Angle-Beam Reference Block

NOTE A1.2—Types DC, SC, and DSC are similar in configuration to those of the same type described in AWS documents. The miniature angle-beam block is a U.S. version of IIW Reference Block 2 but with significant variations. Block material must be specified by the using parties. Refer also to A1.2.1.

A1.5.2 Typical standardization uses of these blocks are listed in Table A1.1 and the corresponding search unit positions are illustrated in Fig. A1.13. The specific standardization procedures used are determined by the application involved.

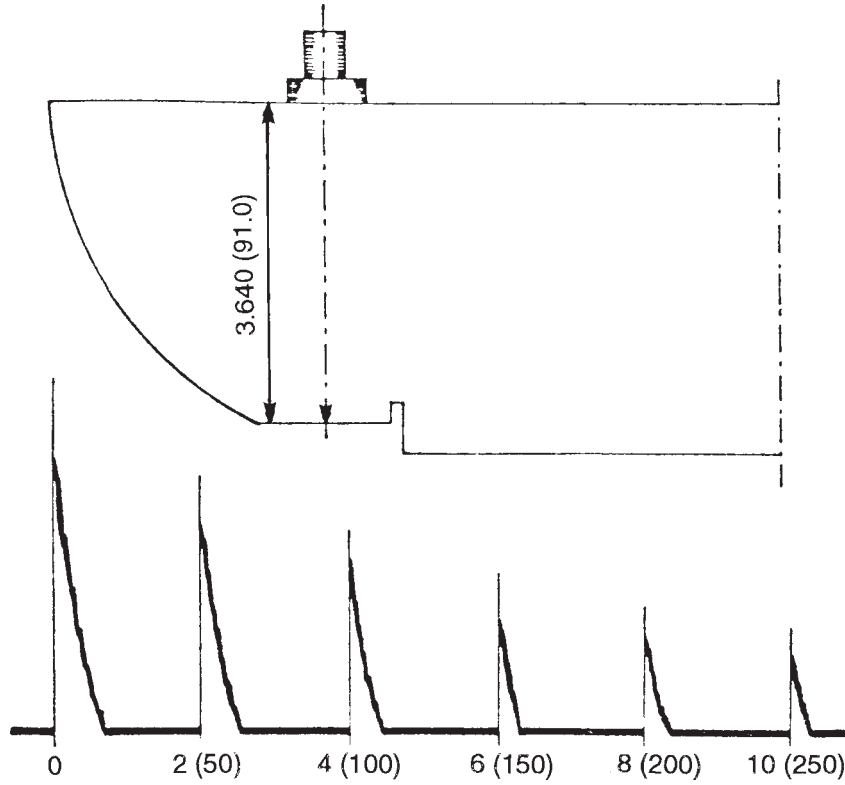

NOTE 1—English and metric units shown on this figure represent values used for two different blocks, that is, U.S. Customary Block and a Metric Block, and are not necessarily equivalent values.

FIG. A1.6 Longitudinal Wave Standardization of Sweep for Angle-Beam Shear Wave Examination

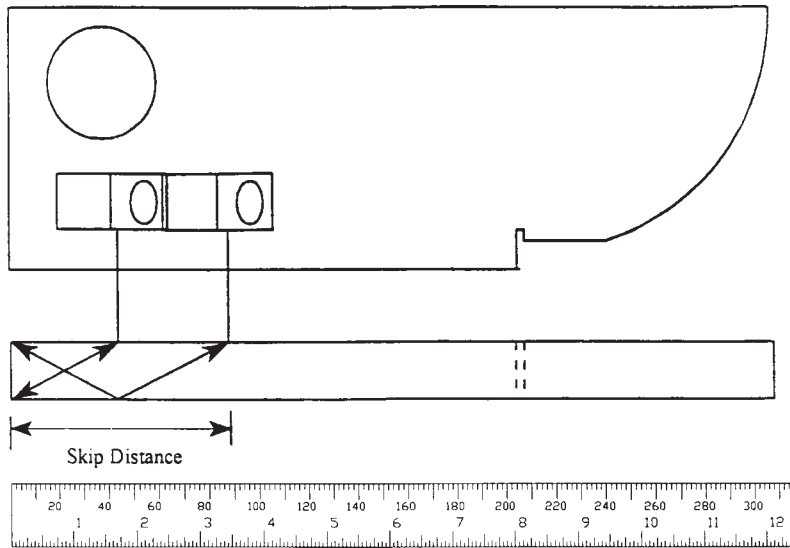

FIG. A1.7 Position for Search Unit when Measuring Distance Standardization for the Sound Path

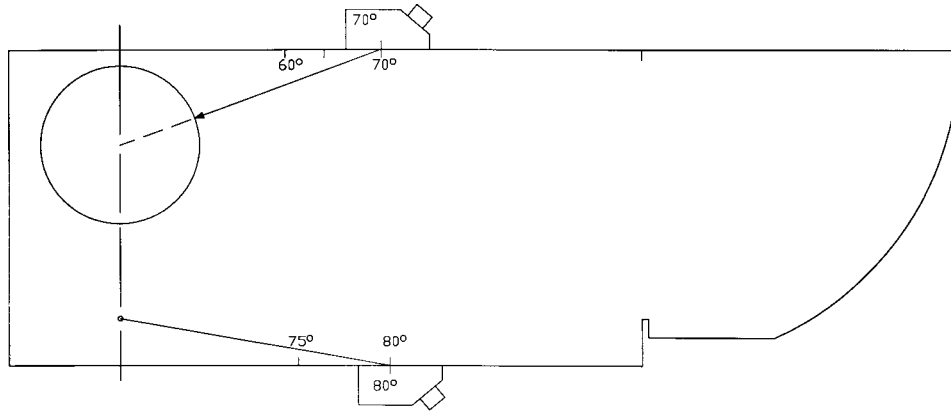

FIG. A1.8 Determination of the Angle of Refraction

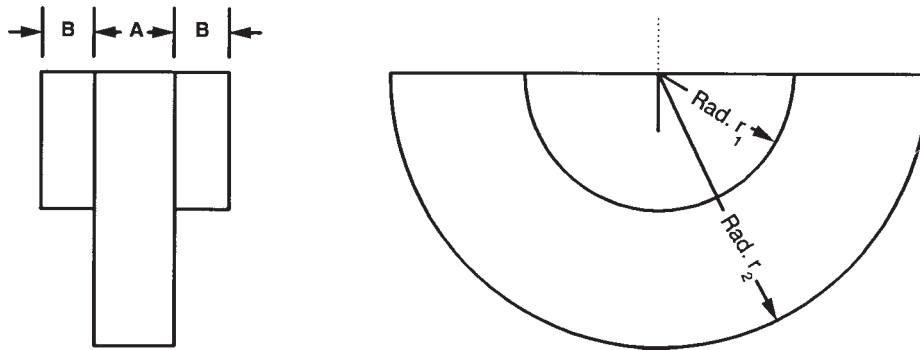

Table of Dimensions

Symbol	U.S. Customary Block		Metric Block	
	Dimension (in.)	Tolerance (in.)	Dimension (mm)	Tolerance (mm)
A	0.500	0.010	12.5	0.2
B	0.250	0.010	6.3	0.2
Rad. r_1	1.000	0.010	25.0	0.2
Rad. r_2	2.000	0.010	50.0	0.2

NOTE 1—Material to be as specified; refer also to A1.5.1.

NOTE 2—All surfaces: Ra 125 μ in. [3.2 μ m] max.

NOTE 3—Index mark at center of curvature to be engraved as shown, two sides.

NOTE 4—In order to avoid sharp edges, minimize plating buildup, or remove in-service nicks and burrs, block edges may be smoothed by beveling or rounding, provided the corner treatment does not reduce the edge dimension by more than 0.020 in. [0.5 mm].

NOTE 5—English and metric units shown on this figure represent values used for two different blocks, that is, U.S. Customary Block and a Metric Block, and are not necessarily equivalent values.

FIG. A1.9 Type DC Distance Reference Blocks

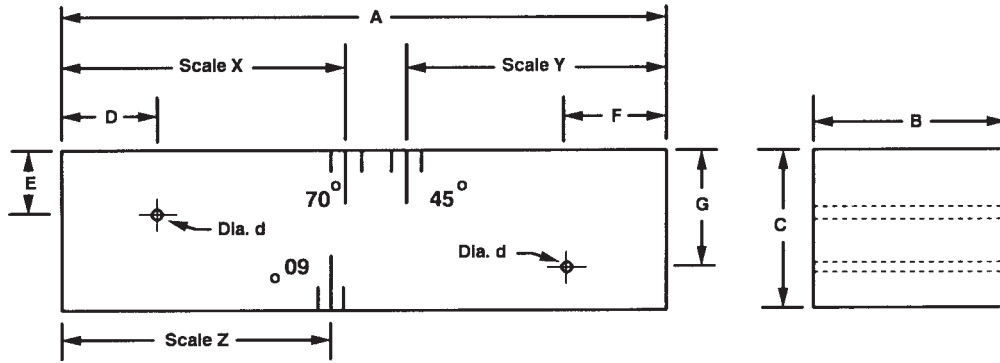

Table of Dimensions

Symbol	U.S. Customary Block		Metric Block	
	Dimension (in.)	Tolerance (in.)	Dimension (mm)	Tolerance (mm)
A	3.000	0.005	75.0	0.1
B	1.250	0.05	32.0	1.0
C	0.905	0.005	22.6	0.1
D	0.500	0.005	12.5	0.1
E	0.384	0.005	9.6	0.1
F	0.500	0.005	12.5	0.1
G	0.727	0.005	18.2	0.1
Dia. d	0.0625	0.0005	1.6	0.02
SCALE X 70°	1.450	0.005	36.3	0.1
	1.555	0.005	38.9	0.1
	1.682	0.005	42.1	0.1
SCALE Y 45°	1.178	0.005	29.5	0.1
	1.227	0.005	30.7	0.1
	1.280	0.005	32.0	0.1
SCALE Z 60°	1.334	0.005	33.4	0.1
	1.402	0.005	35.1	0.1
	1.480	0.005	37.0	0.1

NOTE 1—Material to be as specified; refer also to A1.5.1.

NOTE 2—Surface finish: External surfaces—Ra 125 μin. [3.2 μm] max.

Inner surface of test holes—Ra 32 μin. [0.8 μm] max.

NOTE 3—Scale marks and legends to be engraved at positions indicated.

NOTE 4—In order to avoid sharp edges, minimize plating buildup, or remove in-service nicks and burrs, block edges may be smoothed by beveling or rounding, provided the corner treatment does not reduce the edge dimension by more than 0.020 in. [0.5 mm].

NOTE 5—English and metric units shown on this figure represent values used for two different blocks, that is, U.S. Customary Block and a Metric Block, and are not necessarily equivalent values.

FIG. A1.10 Type SC Sensitivity Reference Blocks

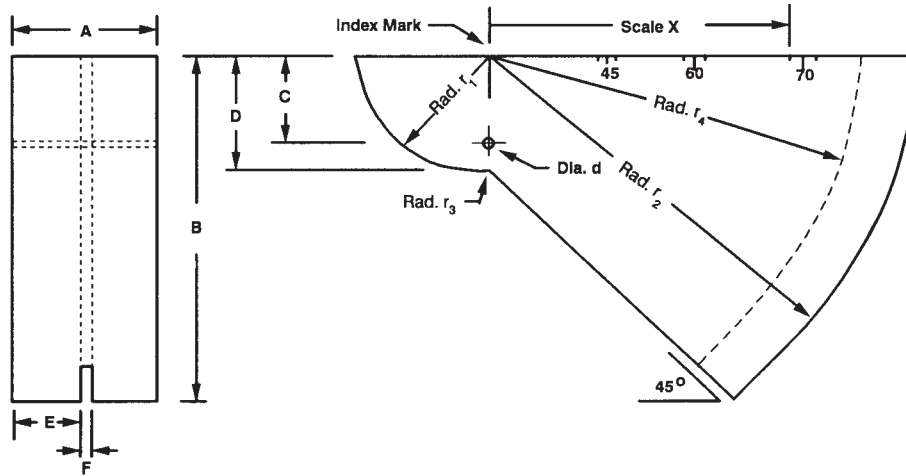

Table of Dimensions

Symbol	U.S. Customary Block		Metric Block	
	Dimension (in.)	Tolerance (in.)	Dimension (mm)	Tolerance (mm)
A	1.000	0.005	25.0	0.1
B	2.500	0.005	62.5	0.1
C	0.750	0.005	18.8	0.1
D	1.000	0.005	25.0	0.1
E	0.484	0.005	12.1	0.1
F	0.032	0.005	0.8	0.1
Dia. d	0.125	0.002	3.2	0.05
Rad. r ₁	1.000	0.005	25.0	0.1
Rad. r ₂	3.000	0.005	75.0	0.1
Rad. r ₃	0.25	0.02	6.3	0.5
Rad. r ₄	2.625	0.005	65.6	0.1
SCALE X				
45°	0.699	0.005	17.5	0.1
	0.750	0.005	18.8	0.1
	0.804	0.005	20.1	0.1
60°	1.200	0.005	30.0	0.1
	1.299	0.005	32.5	0.1
	1.410	0.005	35.2	0.1
70°	1.856	0.005	46.4	0.1
	2.061	0.005	51.5	0.1
	2.308	0.005	57.7	0.1

NOTE 1—Material to be as specified; refer also to A1.5.1.

NOTE 2—Notch at radius r₄ to have rectangular cross section.

NOTE 3—Surface finish: External surfaces—Ra 125 μin. [3.2 μm] max.
 Inner surface of test hole—Ra 32 μin. [0.8 μm] max.
 OD of square notch—Ra 32 μin. [0.8 μm] max.

NOTE 4—Index mark at center of curvature to be engraved as shown.

NOTE 5—Scale marks and legends to be engraved at positions indicated.

NOTE 6—In order to avoid sharp edges, minimize plating buildup, or remove in-service nicks and burrs, block edges may be smoothed by beveling or rounding, provided the corner treatment does not reduce the edge dimension by more than 0.020 in. [0.5 mm].

NOTE 7—English and metric units shown on this figure represent values used for two different blocks, that is, U.S. Customary Block and a Metric Block, and are not necessarily equivalent values.

FIG. A1.11 Type DSC Distance and Sensitivity Reference Blocks

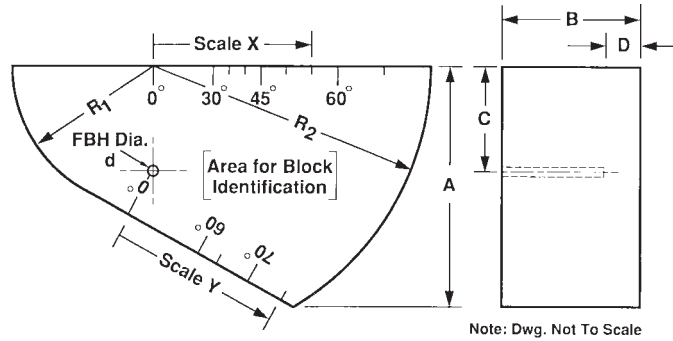

TABLE OF DIMENSIONS

SYMBOL	DIMENSION (in.)	
R ₁	1.000	
R ₂	2.000	
A	1.732	
B	1.000	
C	0.765	
D	0.250	
d (dia)	0.078	

SCALE	ANGLE (to center lines)	DIMENSION (in.)
X	30°*	0.442
	(35°)	0.536
	(40°)	0.642
	45°*	0.765
	(50°)	0.912
	(55°)	1.093
X	60°*	1.325
	(65°)	1.641
Y	60°*	0.585
	(65°)	0.724
Y	70°	0.928
	(75°)	1.260

*These designations to be labeled in degrees as shown - 3/32 high
 Major scale lines 1/4 high
 Other scale lines 1/8 high

All Tolerances .005
 All Surfaces R_a 64μin (or better)
 1 inch = 25.4 mm

NOTE 1—In order to avoid sharp edges, minimize plating buildup, or remove in-service nicks and burrs, block edges may be smoothed by beveling or rounding provided, the corner treatment does not reduce the edge dimension by more than 0.020 in. [0.5 mm].

FIG. A1.12 Type MAB Miniature Angle-Beam Reference Block

TABLE A1.1 Use of Supplementary Blocks for Standardization of Instrument—Lettered Search Unit Locations Indicate Positioning for the Specific Standardizations Listed

Block	Straight Beam Tests			Angle-Beam Tests		
	Beam Angle	Distance	Sensitivity	Beam Index	Distance	Sensitivity
DC	A	A	B	...	B	B
DSC	F	F	C E	D	C E	D E
SC	G H I	...	G H I
MAB	O	N O	J K	L M	J K	L M

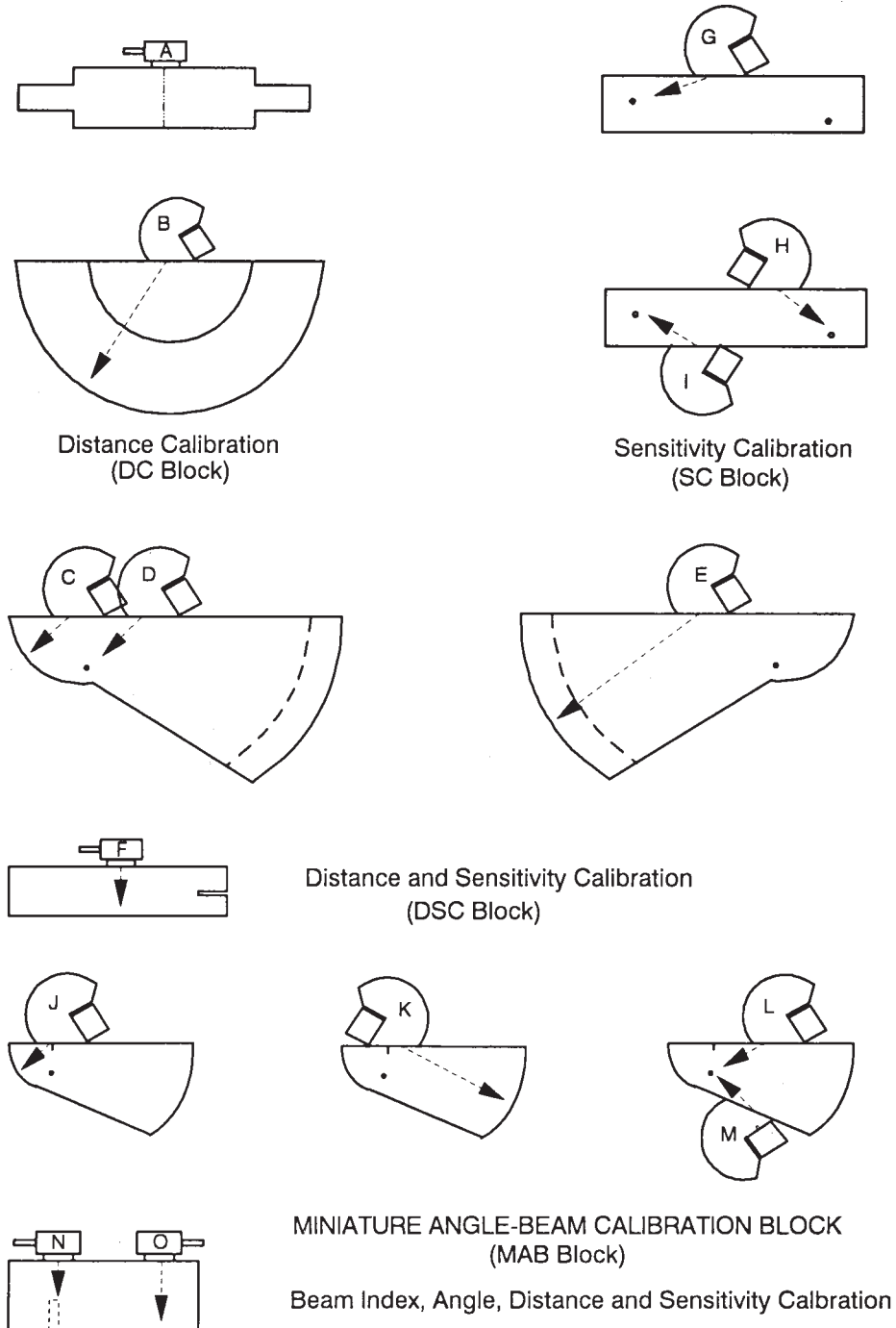

FIG. A1.13 Typical Search Unit Positions of Other Reference Blocks

A2. RECTANGULAR COORDINATE STANDARDIZATION OF ANGLE-BEAM SEARCH UNITS ON THE ASME-TYPE BASIC REFERENCE BLOCK

A2.1 Capabilities of the Method (see Fig. A2.1)

A2.1.1 Sweep range standardization over the examination range.

A2.1.2 Sensitivity standardization of the examination system.

A2.1.3 Distance amplitude standardization.

A2.1.4 Position depth standardization with respect to the front of the search unit and the examination surface.

A2.1.5 Resolution comparison of different examination systems.

A2.1.6 Standardization correction for planar reflectors perpendicular to the examination surface at or near the surface.

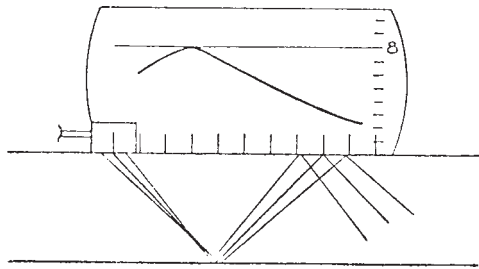

FIG. A2.1 Capabilities of the Method

A2.1.7 Beam spread.

A2.2 Basic Reference Reflectors

A2.2.1 A basic reference reflector is the side of a hole drilled with its axis parallel to the examination surface and perpendicular to the edge of the material. Other reflectors such as the square notch may also be used. The side-drilled hole may be drilled into the weldment if its presence in the weldment is not detrimental to the structure. The side-drilled hole may be drilled into a block machined from excess stock from the weldment or from similar material of the same thickness. See Fig. A2.2.

A2.2.1.1 The hole shall be drilled to a depth of 1½ in. [38 mm] minimum, but where possible the depth shall be 2 in. [51 mm].

A2.2.1.2 The hole diameter is changed with thickness of the weldment in accordance with Table A2.1.

A2.2.1.3 The axis of the hole shall be at the plate thickness centerline for thickness up to 1 in. [25 mm]. In thicker material the axis of the hole shall be ¼ of the thickness below one of the examination surfaces. For simplicity the ¼ T location only is described. The same principles hold for the ½ T hole location but the numbers are different.

A2.2.1.4 The hole shall be positioned ½ of the thickness from the weld if the hole is in the weldment or ½ of the thickness from the end if a block is used. The length of the block shall be at least 3 T and the width shall be 4 in. [102 mm]. For some applications, in order to achieve the 7/8, 8/8, and 9/8 Vee-path positions on the DAC, the selected angle and

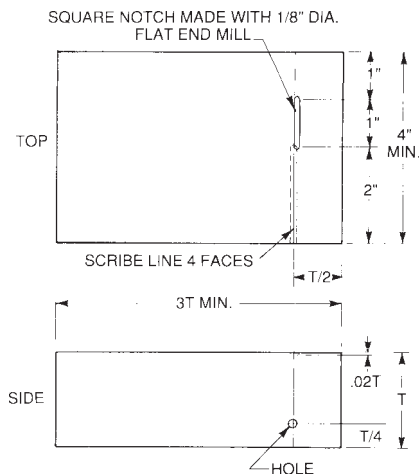

FIG. A2.2 Basic Reference Reflectors

TABLE A2.1 Hole Diameters

NOTE 1—For each additional 2 in. [50.8 mm] of thickness add 1/16 in. [1.60 mm] to the hole diameter.

Thickness (T)		Hole Diameter	
in.	mm	in.	mm
Up through 1	up through 25.4	3/32 ^A	2.40
Over 1 through 2	over 25.4 through 50.8	1/8 ^B	3.20
Over 2 through 4	over 50.8 through 101.6	3/16	4.80
Over 4 through 6	over 101.6 through 152.4	1/4	6.40
Over 6 through 8	over 152.4 through 203.2	5/16	7.90

^A The 3/32-in. [2.40-mm] diameter hole shall be drilled to a depth of 1.5 in. [38.1 mm] minimum and located at T/2.

^B The 1/8-in. [3.20-mm] diameter and larger holes shall be drilled to a depth of 2 in. [50.8 mm] minimum and located at T/4.

component thickness will require that the block length be significantly greater than 3T.

A2.2.1.5 The weldment thickness dimension will be the plate thickness if plate is used for fabrication of the block.

A2.2.1.6 A scribe line shall be made in the thickness direction through the hole centerline and continued across the two examination surfaces of the block.

A2.2.1.7 A square notch shall be made with a 1/8-in. [3.2-mm] diameter flat end mill and have a depth of 2 % T, and length of 1 in. [25 mm] located on the examination surface ¾ T from the side-drilled hole, running from 2 to 3 in. [51 to 76 mm] from the hole face of the block on the T/2 side of the scribe line with one side of the notch flush with the scribe line.

A2.2.1.8 The examination surfaces of the reference block shall be finished the same as the examination surfaces of the weldment.

A2.3 Sweep Range Standardization (see Fig. A2.3)

A2.3.1 Couple the angle beam search unit to the examination surface ¼ T from the side-drilled hole. Position the search unit for the maximum first indication from the side-drilled hole. Adjust the left edge of this indication to line 1 on the screen with the delay control.

A2.3.2 Slide the search unit away positioning for the maximum third indication from the hole. Adjust the left edge of this indication to line 9 on the screen with the range control.

A2.3.3 Repeat delay and range control adjustments until the first and third hole reflections start at sweep lines 1 and 9.

A2.3.4 Slide the search unit positioning for maximum response from the square notch. The indication will appear at sweep line 4.

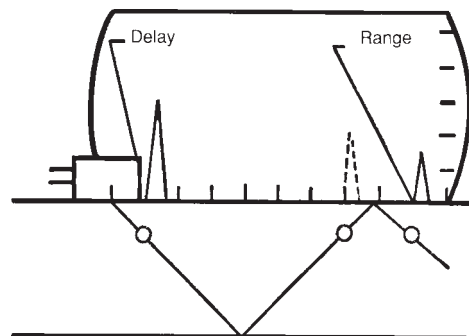

FIG. A2.3 Sweep Range

A2.3.5 Couple the search unit to the examination surface containing the square notch positioning for maximum response from the notch. The indication will appear at sweep line 8.

A2.3.6 Each division on the sweep equals $\frac{1}{8}$ of the Vee path.

A2.4 Sensitivity Standardization (see Fig. A2.4)

A2.4.1 Obtain maximum amplitudes from the $\frac{1}{8}$, $\frac{3}{8}$, $\frac{5}{8}$, $\frac{7}{8}$, and $\frac{9}{8}$ Vee paths to the hole.

A2.4.2 Adjust the sensitivity control to provide an 80 % of-full-screen amplitude from the hole at the path giving the highest amplitude. Mark the peak of the indication on the screen with a grease pencil.

A2.5 Distance-Amplitude Standardization (see Fig. A2.5)

A2.5.1 Without changing the sensitivity control, obtain maximum amplitudes from the other Vee path positions to the hole.

A2.5.2 Mark the peaks of the indications on the screen.

A2.5.3 Connect the screen marks to provide the distance-amplitude curve for the side-drilled hole.

A2.6 Position Depth Standardization (see Fig. A2.6)

A2.6.1 The following measurements may be made with a rule or scale, or marked on an indexing strip. The indexing strip may be any convenient strip of wood, plastic, cardboard, etc. One convenient technique is to use a sheet of paper folded repeatedly until it is about the size of a pencil. The balance of the standardizations in Annex A2 are written based upon the use of the indexing strip. However, the procedures may be transformed for other methods of measurement at the discretion of the operator.

A2.6.1.1 Couple the search unit to the examination surface $\frac{1}{4} T$ from the side-drilled hole. Position the search unit for maximum first response from the hole. Place one end of the indexing strip against the front of the search unit, the other end extending in the direction of the beam on the examination surface. Mark the number 1 on the indexing strip at the scribe line that is directly above the hole (Note A2.1).

A2.6.1.2 Position the search unit for maximum second and third indication from the hole. Keep the same end of the indexing strip against the front of the search unit. Mark numbers 7 and 9 on the indexing strip at the scribe line.

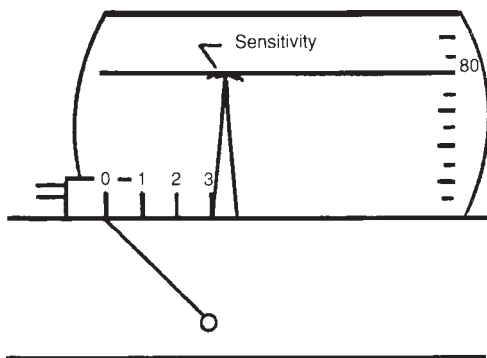

FIG. A2.4 Sensitivity

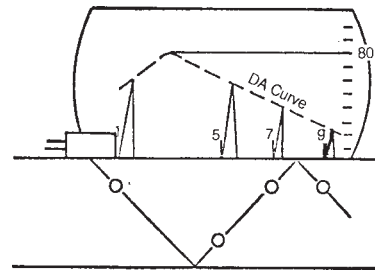

FIG. A2.5 Distance Amplitude

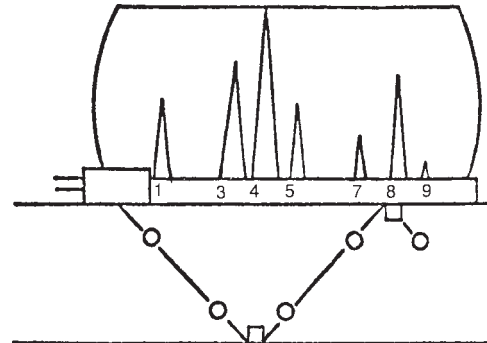

FIG. A2.6 Position Depth

A2.6.1.3 Position the search unit for the maximum notch indication. Mark the number 4 on the indexing strip at the scribe line.

A2.6.1.4 Couple the search unit to the examination surface containing the notch positioning for the maximum indication from the first and second indication from the hole. Mark numbers 3 and 5 on the indexing strip at the scribe line.

A2.6.1.5 Position the search unit for the maximum notch indication. Mark the number 8 on the indexing strip at the notch.

A2.6.1.6 The depth from the examination surface to the reflector is T at 4; $\frac{3}{4} T$ at 3 and 5; $\frac{1}{2} T$ at 2, 6, and 10; $\frac{1}{4} T$ at 1, 7, and 9; and 0 at 8. Interpolation is possible for smaller increments of depth. This measurement may be corrected by the radius of the hole if the radius is considered significant to the reflector location accuracy.

NOTE A2.1—The indexing strip standardization numbers indicate the position directly over the reflector which produces an indication at the same sweep number on the screen.

A2.7 Resolution Comparison of Different Examination Systems (see Fig. A2.7)

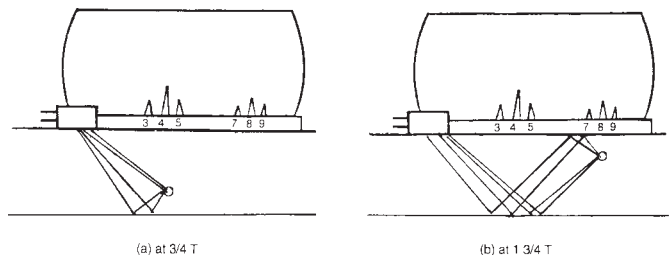

(a) at $\frac{3}{4} T$

(b) at $1 \frac{3}{4} T$

FIG. A2.7 Resolution

A2.7.1 Couple the search unit to the examination surface containing the square notch. Position the search unit so that the number 4 on the indexing strip is at the scribe line above the hole. Three indications may be observed near 3, 4, and 5.

A2.7.2 Adjust the position of the search unit for maximum amplitude on the center indication near 4 and equal indications from near 3 and 5.

A2.7.3 The indication near 3 is the beam spread direct reflection. The indication at 4 is from the beam spread following the path from search unit to hole, to opposite surface, to search unit. The indication near 5 is from the beam spread following the path from search unit to opposite surface to hole and reflecting along the incident path.

A2.7.4 If these indications are easily resolved, couple the search unit to the examination surface $\frac{1}{4} T$ from the side-drilled hole. Position the search unit so that the number 8 on the indexing strip is at the scribe line above the hole. Three indications may be observed near 7, 8, and 9.

A2.7.5 If these indications are resolved, the system has the capability to provide distinct indications from reflector spacing of less than $\frac{1}{8}$ of the Vee path.

A2.7.6 If proof of better resolution is required the above steps should be repeated on an alternative hole of the same size $\frac{1}{2} T$ from the other end of the block, $\frac{1}{8} T$ from the examination surface containing the square notch. By using the alternative hole one may determine if the system has the capability to provide distinct indications from reflector spacing of less than $\frac{1}{16}$ of the Vee path.

A2.8 Planar Reflectors

A2.8.1 *Standardization Correction for Planar Reflectors Perpendicular to the Examination Surface at or near Either Surface*—The 45° angle-beam shear wave reflects well from such a reflector; however, mode conversion and redirection of reflection occurs to part of the beam when a 60° angle-beam shear wave hits the same reflector. This problem also exists to a lesser degree throughout the 57 to 80° angle-beam shear-wave range. This correction is required in order to be equally critical of such an imperfection regardless of the examination beam angle. See Fig. A2.8.

A2.8.1.1 Couple the search unit to the examination surface $\frac{1}{4} T$ from the hole. Position for maximum amplitude from the square notch. “X” mark the peak of the indication on the screen near sweep line 4.

A2.8.1.2 Couple the search unit to the examination surface containing the square notch. Position for maximum amplitude from the square notch. “X” mark the peak of the indication on the screen near sweep line 8.

A2.8.1.3 The square notch may give an indication 2 to 1 above the DA Curve with a 45-deg angle beam and $\frac{1}{2}$ of the

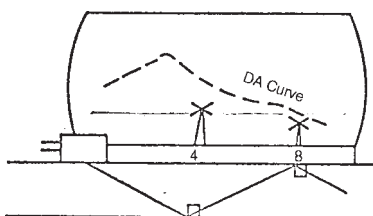

FIG. A2.8 Planar Reflectors

DA Curve with a 60-deg angle beam. Therefore, the indication from the square notch must be considered when evaluating reflectors at the top or bottom surface.

A2.9 Beam Spread

A2.9.1 Beam spread measurements may be made on the side-drilled hole. For example, the half-amplitude beam limits may be plotted by calibrating the beam centerline in accordance with A2.3-A2.6 and proceeding with the following (see Fig. A2.9):

A2.9.1.1 Double the amplitude of the indications (6-dB change).

A2.9.1.2 Couple the search unit to the examination surface. Position for maximum first indication from the hole. Move the search unit toward the hole until the amplitude equals the DA Curve. Mark a small number 1 on the indexing strip at the scribe line. When the search unit covers the scribe line, marks may be made on the side of the search unit.

A2.9.1.3 Move the search unit away from the hole until the amplitude equals the DA Curve. Mark a small number 1 on the indexing strip at the scribe line.

A2.9.1.4 Repeat these measurements at positions 3, 5, 7, and 9 eighths of the Vee path.

A2.9.1.5 Plot these points on a full-scale drawing of the projected beam path. Plot positions with respect to the vertical projection of the front of the search unit; plot depths at 1, 3, 5, 7, and 9 quarters of the thickness equivalent to the 1, 3, 5, 7, and 9 eighths of the Vee path.

A2.9.1.6 Draw a straight line through the centerline points and extend the line to the search unit. This indicates the beam centerline point on the search unit. The beam angle may be read with a protractor as the angle between the beam centerline and a perpendicular line to the examination surface, such as the search-unit front-line projection. Alternatively the beam angle

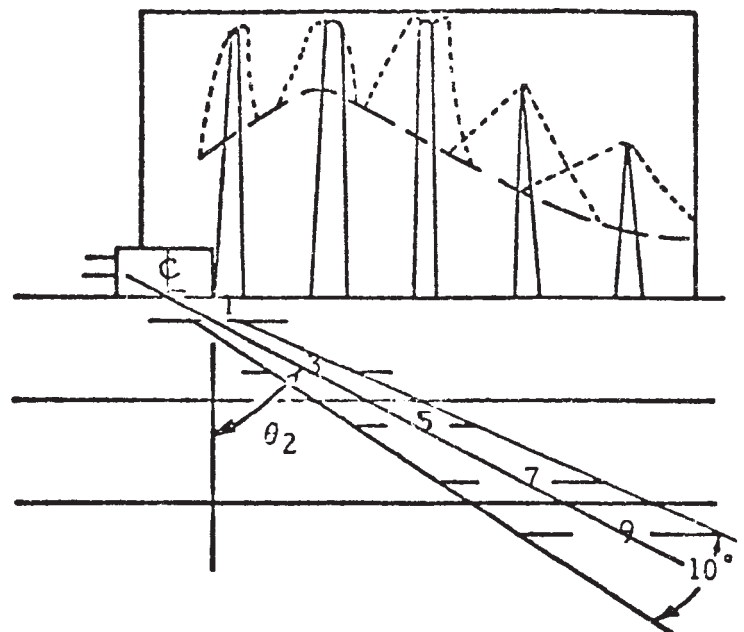

FIG. A2.9 Beam Spread

may be computed by using the 1-to-9 position distance from the indexing strip position depth standardization, where refracted beam angle,

$$\theta_2 = \arctan \left(\frac{1\text{-to-9 position distance}}{2T} \right) \quad (\text{A2.1})$$

A2.9.1.7 Connect small number points 1, 3, 5, 7, and 9 at the lower edge of the beam and the similar points at the upper edge of the beam. These two lines represent the half-amplitude limits of the beam measured on the side-drilled hole. When spread is indicated, draw a straight line through points 5, 7, and 9 at the upper and lower edges of the beam. Project the lines to cross and measure the angle between the lines. This is the

beam-spread angle of the full beam measured at the half-amplitude level on the side-drilled hole.

A2.10 Alternative Standardization Paths

A2.10.1 Alternative standardization paths may be used. For example, 5/8 of the Vee path is sometimes used with the 70° angle beam; 20/8 of the Vee path may be used in thin materials; or 3/8 to 13/8 may be used to avoid wedge noise but keep the upward and downward angle-beam paths. The preceding measurements may be made on these alternative paths but the position location and depth numbers must be changed accordingly. See Fig. A2.10 .

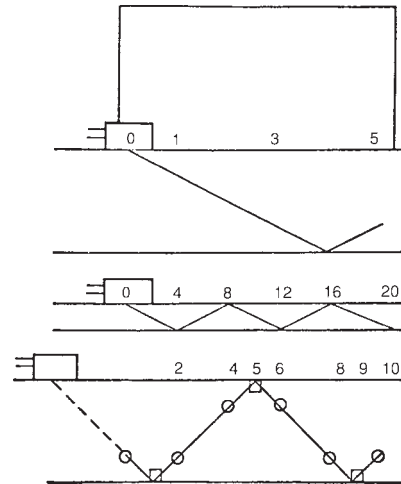

FIG. A2.10 Alternative Paths

ASTM International takes no position respecting the validity of any patent rights asserted in connection with any item mentioned in this standard. Users of this standard are expressly advised that determination of the validity of any such patent rights, and the risk of infringement of such rights, are entirely their own responsibility.

This standard is subject to revision at any time by the responsible technical committee and must be reviewed every five years and if not revised, either reapproved or withdrawn. Your comments are invited either for revision of this standard or for additional standards and should be addressed to ASTM International Headquarters. Your comments will receive careful consideration at a meeting of the responsible technical committee, which you may attend. If you feel that your comments have not received a fair hearing you should make your views known to the ASTM Committee on Standards, at the address shown below.

This standard is copyrighted by ASTM International, 100 Barr Harbor Drive, PO Box C700, West Conshohocken, PA 19428-2959, United States. Individual reprints (single or multiple copies) of this standard may be obtained by contacting ASTM at the above address or at 610-832-9585 (phone), 610-832-9555 (fax), or service@astm.org (e-mail); or through the ASTM website (www.astm.org).