



## Standard Guide for Electromagnetic Acoustic Transducers (EMATs)<sup>1</sup>

This standard is issued under the fixed designation E 1774; the number immediately following the designation indicates the year of original adoption or, in the case of revision, the year of last revision. A number in parentheses indicates the year of last reapproval. A superscript epsilon ( $\epsilon$ ) indicates an editorial change since the last revision or reapproval.

### INTRODUCTION

*General*—The usefulness of ultrasonic techniques is well established in the literature of nondestructive examination. The generation of ultrasonic waves is achieved primarily by means of some form of electromechanical conversion, usually the piezoelectric effect. This highly efficient method of generating ultrasonic waves has a disadvantage in that a fluid is generally required for mechanical coupling of the sound into the material being examined. The use of a couplant generally requires that the material being examined be either immersed in a fluid or covered with a thin layer of fluid.

*Principle*—An electromagnetic acoustic transducer (EMAT) generates and receives ultrasonic waves without the need to contact the material in which the acoustic waves are traveling. The use of an EMAT requires that the material to be examined be electrically conductive or ferromagnetic, or both. The EMAT as a generator of ultrasonic waves is basically a coil of wire, excited by an alternating electric current, placed in a uniform magnetic field near the surface of an electrically conductive or ferromagnetic material. A surface current is induced in the material by transformer action. This surface current in the presence of a magnetic field experiences Lorentz forces that produce oscillating stress waves. Upon reception of an ultrasonic wave, the surface of the conductor oscillates in the presence of a magnetic field, thus inducing a voltage in the coil. The transduction process occurs within an electromagnetic skin depth. An EMAT forms the basis for a very reproducible noncontact system for generating and detecting ultrasonic waves.

### 1. Scope

1.1 This guide is intended primarily for tutorial purposes. It provides an overview of the general principles governing the operation and use of electromagnetic acoustic transducers (EMATs) for ultrasonic examination.

1.2 This guide describes a non-contact technique for coupling ultrasonic energy into an electrically conductive or ferromagnetic material, or both, through the use of electromagnetic fields. This guide describes the theory of operation and basic design considerations as well as the advantages and limitations of the technique.

1.3 This guide is intended to serve as a general reference to assist in determining the usefulness of EMATs for a given application as well as provide fundamental information regarding their design and operation. This guide provides guidance for the generation of longitudinal, shear, Rayleigh, and Lamb wave modes using EMATs.

1.4 This guide does not contain detailed procedures for the use of EMATs in any specific applications; nor does it promote

the use of EMATs without thorough testing prior to their use for examination purposes. Some applications in which EMATs have been applied successfully are outlined in Section 9.

1.5 *This standard does not purport to address all of the safety concerns, if any, associated with its use. It is the responsibility of the user of this standard to establish appropriate safety and health practices and determine the applicability of regulatory limitations prior to use.*

### 2. Referenced Documents

#### 2.1 ASTM Standards:

E 127 Practice for Fabricating and Checking Aluminum Alloy Ultrasonic Standard Reference Blocks<sup>2</sup>

E 428 Practice for Fabrication and Control of Steel Reference Blocks Used in Ultrasonic Examination<sup>2</sup>

E 1065 Guide for Evaluating Characteristics of Ultrasonic Search Units<sup>2</sup>

E 1316 Terminology for Nondestructive Examinations<sup>2</sup>

#### 2.2 ASNT Document:

<sup>1</sup> This guide is under the jurisdiction of ASTM Committee E07 on Nondestructive Testing and is the direct responsibility of Subcommittee E07.06 on Ultrasonic Method.

Current edition approved December 10, 1996. Published February 1997. Originally published as E 1774 – 95. Last previous edition E 1774 – 95.

<sup>2</sup> *Annual Book of ASTM Standards*, Vol 03.03.

Recommended Practice SNT-TC-1A Personnel Qualifications and Certification in Nondestructive Testing<sup>3</sup>

### 3. Terminology

3.1 *Definitions*—Related terminology is defined in Terminology E 1316.

3.2 *Definitions of Terms Specific to This Standard:*

3.2.1 *electromagnetic acoustic transducer (EMAT)*—an electromagnetic device for converting electrical energy into acoustical energy in the presence of a magnetic field.

3.2.2 *Lorentz forces*—forces applied to electric currents when placed in a magnetic field. Lorentz forces are perpendicular to the direction of both the magnetic field and the current direction. Lorentz forces are the forces behind the principle of electric motors.

3.2.3 *magnetostrictive forces*—forces arising from magnetic domain wall movements within a magnetic material during magnetization.

3.2.4 *meander coil*—an EMAT coil consisting of periodic, winding, non-intersecting, and usually evenly-spaced conductors.

3.2.5 *pancake coil (spiral)*—an EMAT coil consisting of spirally-wound, usually evenly-spaced conductors.

3.2.6 *bulk wave*—an ultrasonic wave, either longitudinal or shear mode, used in nondestructive testing to interrogate the volume of a material.

### 4. Significance and Use

4.1 *General*—Ultrasonic testing is a widely used nondestructive method for the examination of a material. The majority of ultrasonic examinations are performed using transducers that directly convert electrical energy into acoustic energy through the use of piezoelectric crystals. This guide describes an alternate technique in which electromagnetic energy is used to produce acoustic energy inside an electrically conductive or ferromagnetic material. EMATs have unique characteristics when compared to conventional piezoelectric ultrasonic search units, making them a significant tool for some ultrasonic examination applications.

4.2 *Specific Advantages*—Since the EMAT technique is noncontacting, it requires no fluid couplant. Important consequences of this include applications to moving objects, in remote or hazardous locations, to objects at elevated temperatures, or to objects with rough surfaces. The technique is environmentally safe since it does not use potentially polluting or hazardous chemicals. The technique facilitates the rapid scanning of components having complex geometries. EMAT signals are highly reproducible as a consequence of the manner in which the acoustic waves are generated. EMATs can produce horizontally polarized shear (SH) waves without mode conversion and can accommodate scanning while using SH waves. (Note that in order to produce this wave mode by conventional ultrasonic techniques, either an epoxy or a highly viscous couplant is required. Thus, conventional ultrasonic techniques do not lend themselves easily to scanning when

using SH wave modes.) Also, EMATs provide for the capability to steer shear waves electronically.

4.3 *Specific Limitations*—EMATs have very low efficiency. The insertion loss of EMATs can be as much as 40 dB or more when compared to conventional ultrasonic methods. The EMAT technique can be used only on materials that are electrical conductors or ferromagnetic. The design of EMAT probes is usually more complex than comparable piezoelectric search units. Due to their low efficiency, EMATs usually require more specialized instrumentation for the generation and detection of ultrasonic signals. High transmitting currents, low-noise receivers, and careful electrical matching is imperative in system design. In general, EMAT probes are application-specific, in the same way as piezoelectric transducers.

### 5. Calibration and Standardization

5.1 *Reference Standards*—As with conventional piezoelectric ultrasonic examinations, it is imperative that a set of reference samples exhibiting the full range of expected material defect states be acquired or fabricated and consequently examined by the technique to establish sensitivity (see Practices E 127 and E 428).

5.2 *Transducer Characterization*—Many of the conventional contact piezoelectric search unit characterization procedures are generally adaptable to EMAT transducers with appropriate modifications, or variations thereof (see Guide E 1065). Specific characterization procedures for EMATs are not available and are beyond the scope of this document.

### 6. Theory (1-3)<sup>4</sup>

6.1 *Nonmagnetic Conducting Materials*—The mechanisms responsible for the generation of elastic waves in a conducting material are dependent on the characteristics of that material. The generation of acoustic waves in a nonmagnetic conductive material is a result of the Lorentz force acting on the lattice of the material. In an effort to understand the action of the Lorentz force, one can use the free electron model of solids. According to the free electron model of conductors, the outer valence electrons have been stripped from the atomic lattice, leaving a lattice of positively charged ions in a sea of free electrons. In order to generate elastic waves in a material, a net force must be transmitted to the lattice of the material. If only an electromagnetic field is generated in a conductor (via an eddy current-type coil), the net force on the lattice is zero because the forces on the electrons and ions are equal and opposite. For example:

$$\text{force on electrons} = -qE$$

$$\text{force on ions} = +qE$$

where:

$q$  = electron charge, and

$E$  = electric field vector of EMAT wave.

However, if the same electromagnetic field is generated in the presence of an applied static magnetic field, a net force is

<sup>3</sup> Available from American Society for Nondestructive Testing, 1711 Arlington Plaza, Columbus, OH 43228.

<sup>4</sup> The boldface numbers in parentheses refer to the list of references at the end of this guide.

transmitted to the lattice and results in the generation of elastic waves. The reason for this net force is the Lorentz force acting on the electrons and ions.

$$\text{Lorentz force} = F_L = qv \times B \quad (1)$$

where:

$v$  = velocity of electrons, and

$B$  = static magnetic inductor vector.

Since the electrons are free to move and the ions are bound to the lattice, the Lorentz force on the electrons is much greater due to its velocity dependence, and this force is transmitted to the ions in the lattice via the collision process.

**6.2 Magnetic Conducting Materials**—For magnetic conductors, other forces such as magnetostrictive forces, in addition to the Lorentz force, influence ion motion. In magnetic materials, the electromagnetic field can modulate the magnetization in the material to produce periodic magnetostrictive stresses that must be added to the stresses caused by the Lorentz force. The magnetostrictive stresses are complicated and depend on the magnetic domain distribution, which also depends on the strength and direction of the applied static magnetic field. Although the magnetostrictive forces present in magnetic conductors may complicate the theoretical analysis, this additional coupling can be an asset because it can significantly increase the signal strength compared to that obtained by the Lorentz force alone. At high applied magnetic field strengths above the magnetic saturation of the material, the Lorentz force is the only source of acoustic wave generation. The magnetostrictive force dominates at low field strengths, however, and the acoustic energy can be much greater than for corresponding field strengths with only the Lorentz mechanism. Therefore, a careful examination of the relationship at low applied field strengths should be made in order to take full advantage of the magnetostrictive effort in magnetic materials.

**6.3 Wave Modes**—With the proper combination of magnet and coil design, EMATs can produce longitudinal, shear, Rayleigh, and Lamb wave modes (2-4). The direction of the applied magnetic field, geometry of the coil, and frequency of the electromagnetic field will determine the type of wave mode generated with EMATs.

**6.3.1 Longitudinal Wave Mode**—Fig. 1 illustrates how the direction of the applied static magnetic field in a conductor and the resultant direction of the Lorentz force can produce longitudinal elastic waves. For longitudinal wave generation, the Lorentz force and thus ion displacement is perpendicular to the surface of the conductor. The efficiency of longitudinal wave generation, as compared with other modes excited in ferromagnetic materials, is very low, and has no practical relevance.

**6.3.2 Shear Wave Modes**—Fig. 2 shows how the direction of the applied static magnetic field in a conductor and the resultant direction of the Lorentz force can produce shear elastic waves. For shear wave generation, the Lorentz force and thus ion displacement is parallel to the surface of the conductor. EMATs are also capable of producing shear wave modes with both vertical and horizontal polarizations. The distinction between these two shear wave polarization modes is illustrated in Fig. 3.

**6.3.3 Rayleigh Wave Mode**—In general, for Rayleigh or surface wave generation, the applied static magnetic field will be oriented perpendicular to the surface of the conductor in the same manner used for shear wave propagation. A meander line or serpentine-type coil is used to provide a tuned frequency EMAT. The frequency of the EMAT is determined by the geometry (that is, line spacing) of the meander lines in the coil. By proper selection of frequency, it is possible to propagate only Rayleigh or surface waves. If the thickness of the material is at least five times the acoustic wavelength that is determined by the frequency and wave velocity, then Rayleigh wave generation is essentially ensured.

**6.3.4 Lamb Wave Modes**—The various Lamb wave modes (symmetric and antisymmetric) can be generated in a manner similar to Rayleigh wave propagation. For Lamb wave production, the tuned frequency of the meander line coil is chosen to give the desired Lamb wave mode and is dependent on the material thickness.

## 7. System Configuration

**7.1 Transducers**—As in conventional piezoelectric-type ultrasonic examination, there are basically two types of EMATs

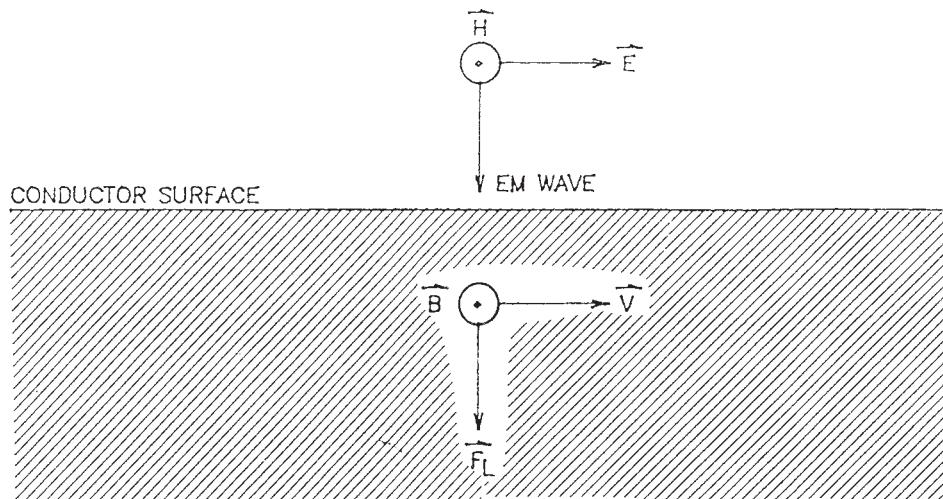

FIG. 1 EMAT Generation of Longitudinal Waves

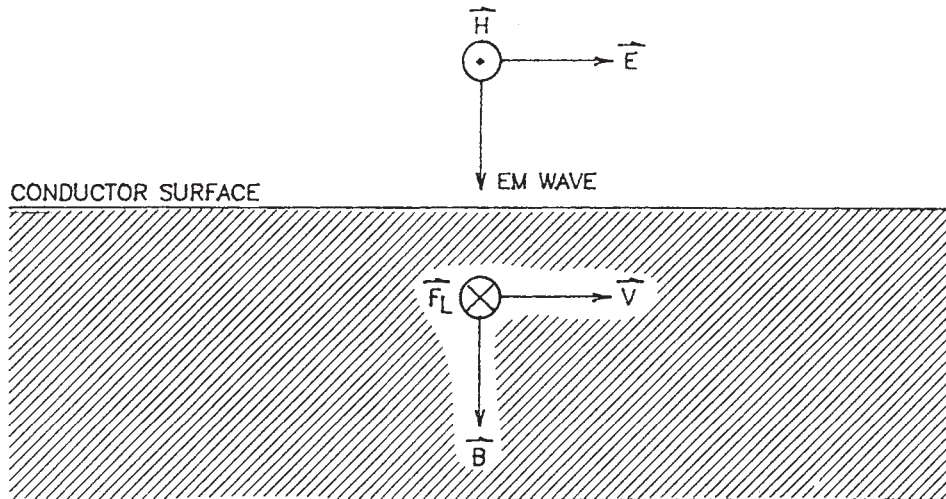

FIG. 2 EMAT Generation of Shear Waves

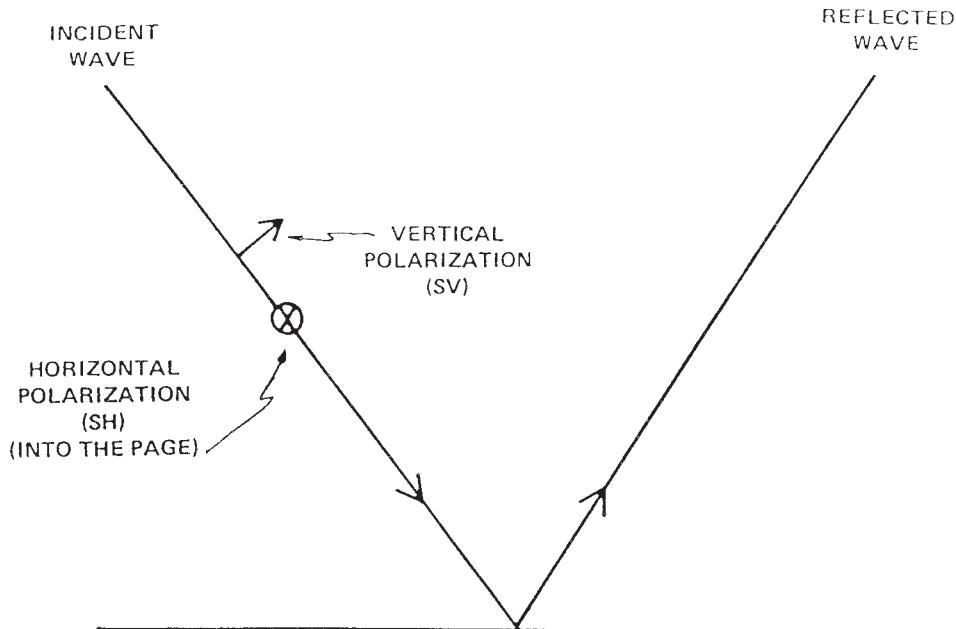

FIG. 3 Illustration of Horizontal and Vertical Polarizations for Shear Waves

with respect to beam direction. EMATs can be designed for either straight or angle beam examination. Examples of these two types of transducers are presented in the following sections.

**7.1.1 Straight Beam**—The spiral or pancake coil design is one of the most efficient EMATs for producing a straight ultrasonic beam. The direction of the applied magnetic field is perpendicular to the plane of the spiral coil, as shown in Fig. 4. The magnetic field can be produced by a permanent magnet, an electromagnet, or a pulsed magnet. Assuming that there is no fringing of the magnetic field parallel to the coil, a radially polarized shear wave is produced. Since there is always a small gradient of the field lines parallel to the coil, a small amplitude longitudinal wave will also be present. However, the longitudinal wave component can be held to a minimum by the proper

design of the EMAT. The same holds for butterfly coils, placed in a perpendicular magnetic field with spatially alternating magnetic direction for the excitation of linearly-polarized shear waves.

**7.1.2 Angle Beam**—The meander line or serpentine coil EMAT can be designed for angle beam ultrasonic examination. The orientation of the applied magnetic field is perpendicular to the plane of the meander coil, as shown in Fig. 5. The geometry of the meander lines is illustrated in Fig. 6. Due to the geometry of the meander lines, periodic surface stresses are generated in the specimen. These stresses produce ultrasonic waves when the following phase matching condition is fulfilled:

$$n\lambda = 2L \quad (2)$$

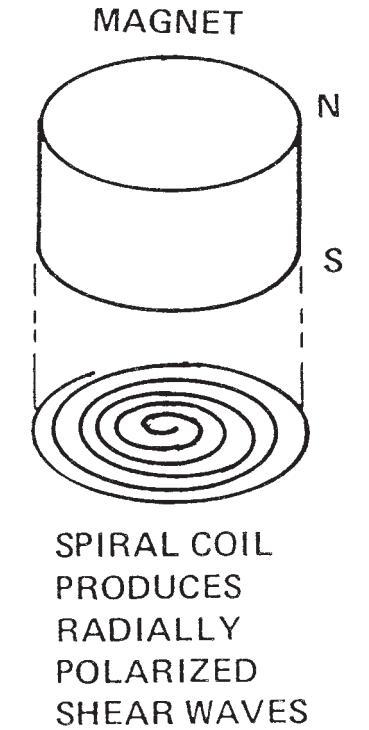

FIG. 4 Diagram of Spiral Coil EMAT

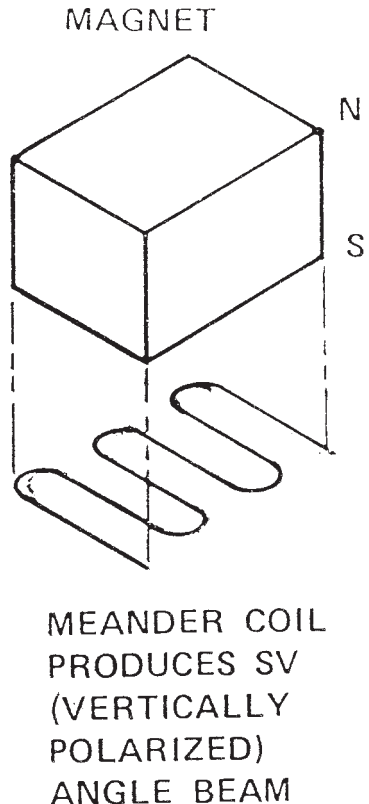

FIG. 5 Diagram of Meander Coil EMAT

where:  
 $n$  = odd integer,  
 $\lambda$  = Rayleigh wavelength, and  
 $L$  = spacing between adjacent coil lines.

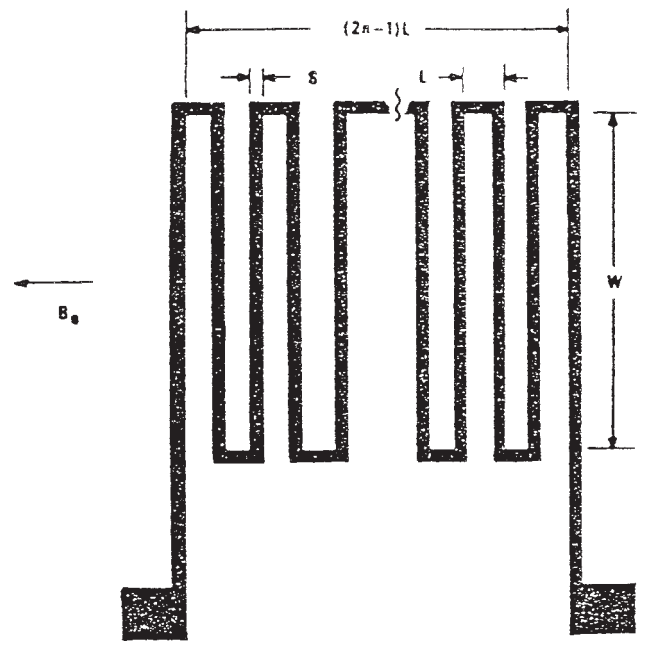

FIG. 6 Meander Line EMAT Geometry

Phase matching to bulk waves is achieved when the projection of the wire spacing into the propagation direction of the selected bulk mode is given by

$$n\lambda = 2L \sin \theta \tag{3}$$

where:  
 $\theta$  = angle from surface normal.

This equation applies to both shear and longitudinal waves in general. Therefore, the meander EMAT can be used to generate either shear or longitudinal angle beams where the beam angle is controlled by the frequency of the electromagnetic field. The polarization of the shear waves is vertical, as illustrated in Fig. 3. Because of differences in the velocities of longitudinal and shear waves, there will be a low-frequency cutoff for these two wave modes. By proper selection of frequency, it is possible to propagate only a Rayleigh or shear wave, whereas longitudinal waves must be accompanied by shear waves.

7.1.3 *Frequencies*—EMATs can be designed to provide either narrowband or broadband frequency response. Meander line coils driven by sinusoidal toneburst electrical excitation can be used to provide narrowband response typically within 20 % of center frequency. Center frequencies typically range from 0.1 to 10 MHz. Spiral coils excited by spike pulses are typically used to provide for broadband response.

7.1.4 *Lift-Off*—While EMAT transducers do not require physical contact with the material to be examined, the proximity of the coil to the material does have a major effect on signal strength, given by

$$S(g) = S_0 e^{\left(\frac{-2\pi g}{D}\right)} \tag{4}$$

where:  
 $S$  = signal strength as a function of liftoff (gap),  
 $S_0$  = signal strength at no liftoff,  
 $g$  = gap or liftoff from material surface, and  
 $D$  = coil conductor spacing.

It is therefore important to maintain a minimum liftoff to ensure maximum signal strength. Also, in addition to maintaining a minimum liftoff, it is important to maintain a constant liftoff to ensure the reproducibility of signals and to aid in signal analysis. This criteria is usually met by using a thin material between the EMAT coil and the material to be examined. This material is affixed to the EMAT transducer and can consist of a high-resistivity metal as long as the metal thickness is such that it is much less than the electromagnetic skin depth. Ceramics and carbon-reinforced plastics are also applicable. Such a material is further beneficial in that it provides a good wear surface for scanning applications and thus protects the EMAT coil from damage resulting from wear.

**7.2 Pulser/Receiver**—The electrical characteristics of EMATs are considerably different from piezoelectric transducers used in conventional ultrasonic examination. EMATs generally behave as inductive loads, whereas piezoelectric transducers act as capacitive loads. As a result, it is obvious that the design of the EMAT pulser driver must be different from that of conventional ultrasonic pulsers, albeit some manufacturers are offering pulser boards compatible with and applicable to EMAT applications. Another consideration in the design of EMAT pulsers and receivers is that the insertion loss of EMATs can be as much as 40 dB or more when compared to piezoelectric search units. Noise level and overload recovery time are very important in the design of EMAT receivers because of the high gains required in the preamplifier. For example, in an EMAT pulse-echo system, the preamplifier must be able to withstand the full voltage connected to the EMAT and then recover rapidly enough so that flaw signals can be measured. A detailed design of EMAT pulsers and receivers is beyond the scope of this guide.

**7.3 Data Processor**—Personal computers configured for EMAT signal processing can provide adequate data processing capabilities. With general purpose interface boards and digitizers, personal computers can be used to collect and store EMAT-generated data as well as auxiliary data such as transducer coordinates for scanning applications. Signals can also be evaluated with conventional ultrasonic thickness gages.

**7.4 Sample**—Since the EMAT technique relies on electromagnetic principles to generate and receive acoustic energy from a material, the material is required to possess either the property of being electrically conductive or the property of being ferromagnetic, or both.

**7.4.1 Surface Roughness**—Since the EMAT technique is noncontacting, its sensitivity to variations in surface roughness is much less than that of conventional piezoelectric search units, although the effects of surface roughness and periodicity should not be ignored in developing an examination.

**7.4.2 Sample Temperature**—Since the EMAT transducer does not require an acoustic couplant fluid, applications to elevated temperature samples are more conducive than those of conventional piezoelectric search units.

## 8. Personnel Qualifications

**8.1** Proper application of the EMAT technique requires the involvement of a nondestructive examination (NDE) specialist to plan and guide the examination procedure. Knowledge of the principles of ultrasonic testing is required. Personnel

applying this EMAT technique should be experienced practitioners of conventional ultrasonic examinations and associated methods for signal generation, acquisition, processing, and interpretation, for example, qualified in accordance with ASNT Recommended Practice SNT-TC-1A. Particular emphasis should be placed on personnel having proficiency and sufficient knowledge of electromagnetic theory and signal analysis.

## 9. Applications

### 9.1 Flaw Detection in Base Metal:

**9.1.1 Examination of Steel Bars**—An EMAT system has been designed to examine steel bars for seams and laps (5). The EMAT design consisted of a pulsed magnet and a meander coil. The EMAT produced 2 MHz Rayleigh waves that propagated around the tube for the detection of seams and laps under several mils of scale. This application of the EMAT technique used a pulsed magnet where the electromagnetic skin effect concentrated the magnetic field close to the outer surface of the bar.

### 9.2 Flaw Detection in Welds:

**9.2.1 Examination of Fuel Tank Welds**—A portable EMAT system is being used by NASA for the examination of aluminum welds in the external liquid fuel tanks for the Space Shuttle (6,7). While the system was intended to replace conventional liquid penetrant examination for the detection of surface breaking flaws, it is also used as a supplement to the volumetric examination currently performed with radiography. The EMAT probe uses multiple transducers (Rayleigh waves and vertical polarized shear waves) to perform both a surface examination as well as a volumetric examination of both sides of the weld simultaneously with a single scan down the weld axis.

**9.2.2 Examination of Offshore Platform Welds**—Offshore tension leg platforms have been fabricated for oil recovery in the North Sea. The tension legs are subjected to cyclic loading due to wave motion. This loading promotes crack growth in the circumferential welds. In order to ensure the integrity of tension legs, an EMAT system was developed to provide automated examination of the welds (7). The EMAT probe is attached to a pipe crawler system normally used for automated welding. The ultrasonic waves are electronically steered to different regions of the weld but concentrating mainly on the root and crown areas where crack growth is the most severe. The system is fully automated for computer controlled scanning, data acquisition, display, and recording of the results.

**9.2.3 Examination of Strip Steel Flash Butt Welds**—In order to make a cold rolling operation a continuous process in a steel strip manufacturing facility, the ends of individual coils of steel are electric resistance (ER) welded together prior to the cold rolling process. Consequently, any defect in the welds can cause breaks in the steel strip. An EMAT system was designed to examine the welds with horizontally polarized shear waves just after the ER welding process is completed (7).

**9.2.4 Examination of Vacuum Electric Resistance Welds**—The aerospace industry uses many specialized alloys that must be welded in evacuated chambers with electron beams or high power lasers. The application of conventional nondestructive testing (NDT) techniques requires the time-consuming removal of the components to be examined, the actual examination, and

returning the component to the chamber if a re-weld is necessary. An EMAT technique using angle beam shear waves in a pulse-echo configuration was developed to examine the components inside the vacuum chamber immediately after the weld is formed (8). This is possible since the electromagnetic coupling mechanism can operate across a vacuum and the EMAT can be designed to withstand the high temperature following a weld.

9.3 *Thickness Gaging*—The ultrasonic method has been used widely to perform thickness measurements. The EMAT technique lends itself well to applications requiring high-speed scanning or use at elevated temperatures. Successful applications have been demonstrated for both straight beam and angle beam configurations using both pitch-catch and pulse-echo techniques. Applications to various materials as thin as 0.040 in. (1 mm) have been documented (9,10).

9.4 *Cladding Tests*—The use of EMATs to interrogate an austenitic cladding on a ferritic base metal has been studied (11). Reflection and transmission at the interface between the ferritic base metal and the austenitic cladding by horizontally polarized shear waves offer significant examination capabilities for the application and open new possibilities for NDT.

9.5 *Material Processing Properties*—An EMAT technique has been developed to provide an automated ultrasonic instrument for predicting the drawability of sheet metal nondestructively (12). The instrument measures the travel times of  $S_0$ -mode Lamb waves at 0, 45, and 90 degrees to the rolling direction in sheet metal, computes velocity and Young's modulus in each direction, and then computes parameters used in physical metallurgy to express rolling texture and predict drawability.

9.6 *High-Temperature Tests*—EMAT techniques are particularly useful for ultrasonic applications in high-temperature environments since they do not require a fluid couplant. Numerous successful applications have been demonstrated, from flaw detection to thickness gaging (13-15).

#### 9.7 *Railroad Applications:*

9.7.1 *Railroad Rails*—EMAT techniques adapt well to moving examinations. This capability has allowed several applications within the railroad industry. A lubricant is applied to railroad rails to reduce wear by minimizing friction. Unfortu-

nately, the lubricant complicates NDT because it prevents conventional UT couplants from sufficiently wetting the track to provide an acceptable acoustic couplant. EMATs can excite and receive ultrasonic vibrations through the lubricant layer without difficulty. A prototype EMAT system using both horizontal and normal beam shear waves, with both pitch-catch and pulse-echo procedures, was designed and implemented successfully on a section of test track in Pueblo, Colorado, where the American Association of Railroads conducts tests on the wear rate of lubricated rail under severe loads (16).

9.7.2 *Railroad Wheels*—The wheel rail systems, undercarriage, and wheels are exposed to high loads where thermal and fatigue cracks can occur and lead to total wheel failure. An ultrasonic system using the EMAT technique has been developed for the German Railway Society to provide in-service examinations of the wheel treads on its high-speed trains. The system is capable of detecting and classifying critical discontinuities in motion using a Rayleigh wave technique generated by a meander line coil and relying on both pitch-catch and pulse procedures.

9.8 *Stress Measurements*—Determining the applied or residual stresses in metals through the use of ultrasonic techniques depends on ultrasonic velocity or transit-time procedures. A major source of error arises from the difficulty in determining the influence that material texture has on velocity shift and differentiating this contribution from that created from stress. It has been shown that if two shear wave velocities can be measured where the polarization and propagation directions are interchanged, then a texture independent velocity difference directly proportional to stress can be obtained (18, 19). Successful ultrasonic stress measurements have been made using an EMAT transducer employing horizontally polarized shear waves. The errors associated with transducer coupling are much smaller in such a system.

## 10. Keywords

10.1 angle beam; conductor; electromagnetic acoustic transducer (EMAT); flaw detection; Lamb waves; longitudinal waves; Lorentz forces; magnet; magnetostriction; Rayleigh waves; shear waves; straight beam; thickness gaging; ultrasonics; wave mode; weld examination

## REFERENCES

- (1) Birks, A. S., and Green, R. E., Jr., *Nondestructive Testing Handbook, Ultrasonic Testing, Volume 7*, 2nd edition, pp. 326-340.
- (2) Mason, W. P., and Thurston, R. N., *Physical Acoustics, Vol XIV, Electromagnetic—Ultrasonic Transducers: Principles, Practice and Applications*, Academic Press, New York, NY, 1970, pp. 180-270.
- (3) Thompson, R. B., *Physical Acoustics, Vol XIX, Physical Principles of Measurement with EMAT Transducer*, Academic Press, San Diego, CA, 1990, pp. 156-200.
- (4) Alers, G. A., and Burns, L. R., "EMAT Designs for Selected Applications," *Materials Evaluation*, Vol 45, October 1987, p. 1166.
- (5) Latimer, P. J., and Whaley, H. L., "Electromagnetic Transducers for Generation and Detection of Ultrasonic Waves," *Acousto-Ultrasonics*, Duke, J. C., Jr., ed., Plenum Publishing Corp., 1988 (presented at the Symposium on Acousto-Ultrasonics, Virginia Polytechnic Institute and State University, Blacksburg, VA, July 12-15, 1987).
- (6) Polen, R., Latimer, P., Latham, W., MacLauchlan, D., and Neuschaefer, R., "EMAT Inspection of Space Shuttle External Tank Welds," *JANNAF Nondestructive Evaluation Subcommittee Meeting Proceedings*, 1994.
- (7) Stevens, D. M., Latham, W. M., Latimer, P. J., and MacLauchlan, D. T., "Electromagnetic Acoustic Transducers for NDE," presented at the North American Welding Research Conference, Columbus, OH, October 1994.
- (8) Prati, J., and Bird, C., *Electron Beam Welding System Based on EMATs*, Teledyne CAE, Toledo, OH, 1989.
- (9) Schlader, D. M., et al, "EPRI Portable EMAT Wall Thickness Measurement System," *EPRI 4th Conference on Fossil Plant Inspections*, San Antonio, TX, January 18-20, 1994.
- (10) Alers, G. A., and Wadley, H. G. N., "Monitoring Pipe and Tube Wall Properties During Fabrication in a Steel Mill," *Intelligent Processing*

- of *Materials and Advanced Sensors*, Wadley, H. G. N., Rath, B. B., and Wolf, S. M., eds., American Institute of Metallurgical Engineers, Warrendale, PA, 1987.
- (11) Hubschen, G., and Salzburger, H. J., “Inspection of Dissimilar Metal Welds Using Horizontally Polarized Shear Waves and Electromagnetic Ultrasonic (EMUS) Probes,” *Proceedings of the International Atomic Energy Agency Specialists Meeting on Inspection of Austenitic Dissimilar Materials and Welds*, International Atomic Energy Agency, Vienna, Austria, 1988.
- (12) Papadakis, E. P., et al, “Development of an Automatic Ultrasonic Texture Instrument and Its Transition from Laboratory to Market: A Model for Technology Transfer,” *Materials Evaluation*, Vol 51, January 1993, p. 7.
- (13) Burns, L. R., Alers, G. A., and MacLauchlan, D. T., “A Compact Electromagnetic Acoustic Transducer Receiver for Ultrasonic Testing at Elevated Temperatures,” *Review of Progress in Quantitative Nondestructive Evaluation*, Thompson, D. O., and Chimenti, D. E., eds., Vol 7B, Plenum Press, New York, NY, pp. 1,677 and 1,683.
- (14) Sato, I., et al, *Electromagnetic Ultrasonic Apparatus*, US Patent No. 4 348 903, 1982.
- (15) Maxfield, B. W., Kuramoto, A., and Hulbert, J. K., “Evaluating EMAT Designs for Selected Applications,” *Materials Evaluation*, Vol 45, No. 10, 1987, pp. 1,166 and 1,183.
- (16) Alers, G. A., *EMAT Rail Flaw Detection System*, Contract Report DTFR-53-86-C00015, Department of Transportation, Washington, DC, November 1988.
- (17) Salzburger, H. J., and Repplinger, W., “Automatic In-Motion Inspection of the Tread of Railway Wheels by E.M.A. Excited Rayleigh Waves,” *Conference Proceedings of Ultrasonics International*, Butterworth Scientific, London, England, pp. 497–501.
- (18) Thompson, R. B., Lee, S. S., and Smith, J. F., “Angular Dependence of Ultrasonic Wave Propagation in a Stressed, Orthorhombic Continuum: Theory and Application to Measurement of Stress and Texture,” *Journal of the Acoustical Society of America*, Vol 80, No. 3, 1986, pp. 921–931.
- (19) Halube, U., et al, “Stress Measurements Using Ultrasonics,” *Structural Materials Technology: An NDT Conference*, Technonic Publishing Company, Lancaster, PA, 1994, pp. 92–96.

*ASTM International takes no position respecting the validity of any patent rights asserted in connection with any item mentioned in this standard. Users of this standard are expressly advised that determination of the validity of any such patent rights, and the risk of infringement of such rights, are entirely their own responsibility.*

*This standard is subject to revision at any time by the responsible technical committee and must be reviewed every five years and if not revised, either reapproved or withdrawn. Your comments are invited either for revision of this standard or for additional standards and should be addressed to ASTM International Headquarters. Your comments will receive careful consideration at a meeting of the responsible technical committee, which you may attend. If you feel that your comments have not received a fair hearing you should make your views known to the ASTM Committee on Standards, at the address shown below.*

*This standard is copyrighted by ASTM International, 100 Barr Harbor Drive, PO Box C700, West Conshohocken, PA 19428-2959, United States. Individual reprints (single or multiple copies) of this standard may be obtained by contacting ASTM at the above address or at 610-832-9585 (phone), 610-832-9555 (fax), or service@astm.org (e-mail); or through the ASTM website (www.astm.org).*