



Standard Practice for Eddy-Current Examination of Steel Tubular Products Using Magnetic Saturation¹

This standard is issued under the fixed designation E 309; the number immediately following the designation indicates the year of original adoption or, in the case of revision, the year of last revision. A number in parentheses indicates the year of last reapproval. A superscript epsilon (ε) indicates an editorial change since the last revision or reapproval.

This specification has been approved for use by agencies of the Department of Defense.

1. Scope

1.1 This practice² covers a procedure for applying the eddy-current method to detect discontinuities in ferromagnetic pipe and tubing (Note 1) where the article being examined is rendered substantially non-magnetic by the application of a concentrated, strong magnetic field in the region adjacent to the examining coil.

NOTE 1—For convenience, the term tube or tubular product will hereafter be used to refer to both pipe and tubing.

1.2 The procedure is specifically applicable to eddy-current examination methods using an encircling-coil assembly. However, eddy-current techniques that employ either fixed or rotating probe-coil assemblies may be used to either enhance discontinuity sensitivity on the large diameter tubular products or to maximize the response received from a particular type of discontinuity.

1.3 This practice is intended for use on tubular products having outside diameters from approximately ¼ to 10 in. (6.35 to 254.0 mm). These techniques have been used for smaller and larger sizes however, and may be specified upon contractual agreement between the purchaser and the supplier.

2. Referenced Documents

2.1 ASTM Standards:

E 543 Practice for Evaluating Agencies that Perform Non-destructive Testing³

E 1316 Terminology for Nondestructive Examinations³

2.2 Other Documents:

SNT-TC-1A Recommended Practice for Personnel Qualification and Certification in Nondestructive Testing⁴

ANSI/ASNT CP-189 ASNT Standard for Qualification and Certification of Nondestructive Testing Personnel⁴

¹ This practice is under the jurisdiction of ASTM Committee E-7 on Nondestructive Testing, and is the direct responsibility of Subcommittee E07.07 on Electromagnetic Methods.

Current edition approved Oct. 10, 1995. Published December 1995. Originally published as E 309 – 66 T. Last previous edition E 309 – 93a.

² For ASME Boiler and Pressure Vessel Code applications see related Recommended Practice SE 309 in Section V of that Code.

³ Annual Book of ASTM Standards, Vol 03.03.

⁴ Available from Standardization Documents Order Desk, Bldg. 4 Section D, 700 Robbins Ave., Philadelphia, PA 19111-5094, Attn: NPODS.

2.3 Military Standard:

MIL-STD-410E Nondestructive Testing Personnel Qualification and Certification⁵

3. Terminology

3.1 *General*—Standard terminology relating to electromagnetic examination may be found in Terminology E 1316, Section C, “Electromagnetic Testing.”

4. Summary of Practice

4.1 The examination is conducted using one of two general techniques shown in Fig. 1.

4.1.1 One technique employs one or more exciter and sensor coils that encircle the tube and through which the tubular product to be examined is passed. Some circuit configurations employ one or more coils that concurrently function as both exciters and sensors. Alternating current passes through the exciting coil which, by reason of its proximity, induces corresponding currents (eddy currents) to flow in the tubular product. The sensor coil detects the resultant electromagnetic flux related to these currents. The presence of discontinuities in the tubular product will alter the normal flow of currents and this change is detected by the sensor. The encircling-coil technique is capable of examining the entire circumference of a tubular product.

4.1.2 Another technique employs a probe coil with one or more sensors that are in close proximity to the surface of the tubular product to be examined. Since the probe is generally small and does not encircle the article being examined, it examines only a limited area in the vicinity of the probe. This technique is frequently used for examination of welded tubular products in which only the weld is examined by scanning along the weld zone.

4.1.3 The magnetic permeability of ferromagnetic materials severely limits the depth of penetration of induced eddy currents. Furthermore, the permeability variations inherent in ferromagnetic tubular products often cause anomalous test results. A useful solution to this problem involves the application of a strong external magnetic field in the region of the

⁵ Available from American Society for Nondestructive Testing, 1711 Arlington Plaza, P.O. Box 28518, Columbus, OH 43228-0518.

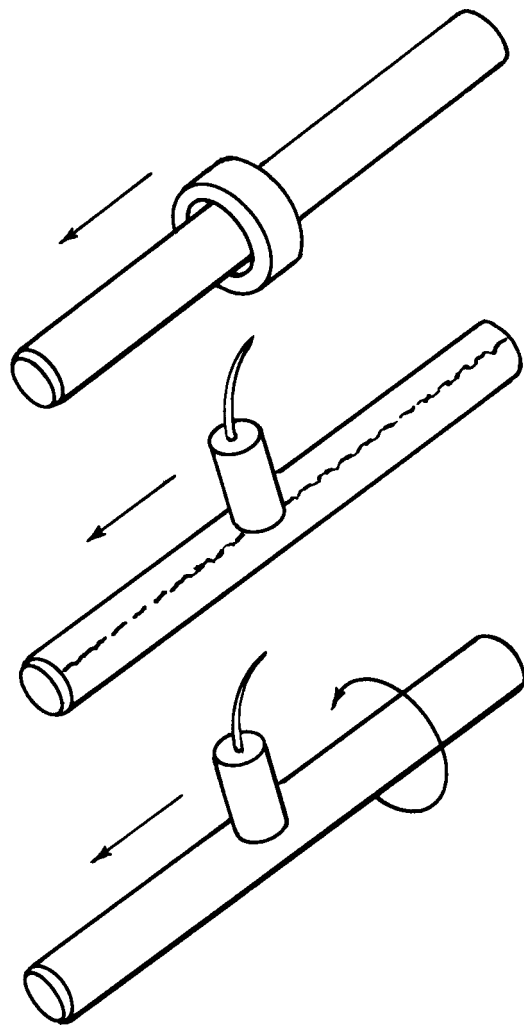

(a) Encircling Coil.

(b) Probe Coil—longitudinal scanning of weld seam only.

(c) Probe Coil—scanning along a spiral path.

FIG. 1 Encircling-Coil and Probe-Coil Techniques for Electromagnetic Testing of Tubular Products

examining coil or probe. This technique, known as magnetic saturation, is applied to a magnetic material, such as a steel tube, to suppress the magnetic characteristics of permeability, hysteresis, etc., so that the material under examination is effectively rendered nonmagnetic. When achieved, this condition allows an eddy-current system to measure and detect electrical resistivity and geometrical variations (including defects) independent of concurrent variations in magnetic properties.

4.1.4 Changes in electromagnetic response caused by the presence of discontinuities are detected by the sensor, amplified, and modified in order to actuate audio or visual indicating devices, or both, a mechanical marker, or a signal-recording device, or a combination of these. Signals can be caused by outer surface, inner surface, or subsurface discontinuities if the eddy-current frequency provides sufficient depth of penetration (see 11.1). The eddy-current method is sensitive to metallurgical variations that occur as a result of processing, thus all received indications are not necessarily indicative of defective tubing.

5. Significance and Use

5.1 The purpose of this practice is to outline a procedure for

the detection and location of discontinuities such as pits, voids, inclusions, cracks, or abrupt dimensional variations in ferromagnetic tubing using the electromagnetic (eddy-current) method. Furthermore, the relative severity of a discontinuity may be indicated, and a rejection level may be set with respect to the magnitude of the indication.

5.2 The response from natural discontinuities can be significantly different than that from artificial discontinuities such as drilled holes or notches. For this reason, sufficient work should be done to establish the sensitivity level and set-up required to detect natural discontinuities of consequence to the end use of the product.

5.3 Eddy-current testing systems are generally not sensitive to discontinuities adjacent to the ends of the tube. The extent of the end effect region can be determined in accordance with 8.6.

6. Basis of Application

6.1 The following acceptance criteria may be specified in the purchase specification, contractual agreement, or elsewhere, and may require agreement between the purchaser and the supplier:

6.1.1 Time of examination or point(s) in the manufacturing process at which the material will be examined,

6.1.2 Maximum time interval between equipment calibration checks,

6.1.3 Methods for determining the extent of end effect,

6.1.4 Size and type of product,

6.1.5 Type, method of manufacture, dimensions, location, and number of artificial discontinuities to be placed on the calibration standard,

6.1.6 Methods of verifying dimensions and allowable tolerances of artificial discontinuities,

6.1.7 Extent of examination, and

6.1.8 Disposition of material with indications.

6.1.9 *Operator Qualification and Certification*—If required, NDT personnel shall be qualified in accordance with a nationally recognized NDT personnel qualification practice or standard such as ANSI/ASNT-CP-189, SNT-TC-1A, MIL-STD-410, or a similar document. The practice or standard used and its applicable revision shall be documented in the contractual agreement between the using parties.

6.1.10 *Qualification of Nondestructive Agencies*—If specified in the contractual agreement, NDT agencies shall be qualified and evaluated in accordance with Practice E 543. The applicable edition of Practice E 543 shall be specified in the contractual agreement.

7. Apparatus

7.1 *Electronic Apparatus*—The electronic apparatus shall be capable of energizing the coils or probes with alternating currents of a selected frequency and shall be capable of sensing the changes in the electromagnetic response of the sensors. Equipment may include appropriate signal processing circuits such as a phase discriminator, filter circuits, etc., as required for the particular application.

7.2 *Encircling-Coil Assembly*—The encircling-coil assembly shall consist of one or more electrical coils that encircle the article being examined.

7.3 *Probe-Coil Assembly*—The probe-coil assembly normally contains an exciting coil and a sensor, although in some cases the exciter and sensor are one and the same.

7.4 *Magnetic Saturation System*—The magnetic saturation system shall consist of a suitable method of applying a strong magnetic field to the region of the tube adjacent to the coil or probe-coil assembly so as to render that region of the tube effectively nonmagnetic. Typical systems employ either permanent magnets or electromagnets.

7.5 *Driving Mechanism*—The movement of the tube through the coil or past the probe shall be performed at uniform speed and with minimum vibration of the tube, coil, and probe.

7.6 *Reference Standard*—The standard used to adjust the sensitivity of the apparatus shall be free of interfering discontinuities and shall be of the same nominal alloy, temper, and dimensions as the tubes to be examined on a production basis. It shall be of sufficient length to permit the spacing of artificial discontinuities to provide good signal resolution and be mechanically stable while in the examining position in the apparatus. Artificial discontinuities placed in the tube shall be one or more of the following types. (See Fig. 2.)

7.6.1 *Notches*—Notches may be produced by Electric Discharge Machining (EDM), milling, or other means. Longitudinal, transverse, or both may be used (Note 2). Orientation,

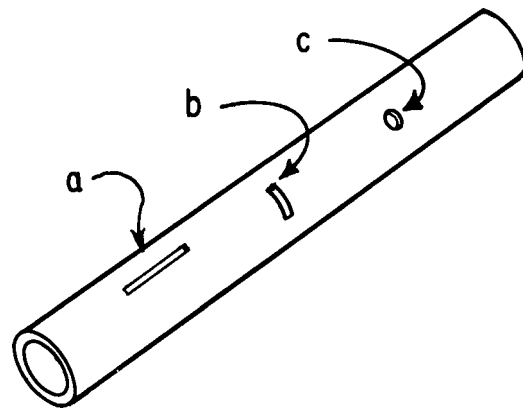

(a) Longitudinal Notch (Milled or EDM) ID, OD, or both.
 (b) Transverse Notch (Milled, Filed, or EDM) ID, OD, or both.
 (c) Drilled Hole (Radially Through One Wall).

FIG. 2 Various Types of Artificial Discontinuities

dimensions (width, length, and depth), and configuration of the notches affect the response of the eddy-current system. Notch depth is usually specified as a percentage of nominal wall thickness of the tubular product being examined. Notches may be placed on the outer, inner, or both surfaces of the reference (calibration) standard. Outer surface notches provide an indication of system response to discontinuities originating on the outer tube surface; whereas inner surface notches provide an indication of system response to discontinuities originating on the inner tube surface.

NOTE 2—Longitudinal notch standards are normally used when testing with a rotating-probe system.

7.6.2 *Holes*—Drilled holes may be used. They are usually drilled completely through the wall. Care should be taken during drilling to avoid distortion of the tube and hole.

7.6.3 The configuration, orientation, and dimensions (diameter of holes and the width, length, and depth of notches) of the artificial discontinuities to be used for establishing acceptance limits should be subject to agreement between the purchaser and the supplier.

8. Adjustment and Standardization of Apparatus

8.1 Select the apparatus, examining frequency, coil or probe configuration, magnetic saturation system, phase discrimination, and other circuitry, as well as speed of examination.

8.2 Fabricate applicable reference standards in accordance with the agreement between the purchaser and the tubing supplier.

8.3 Adjust the field strength of the magnetic saturation system to obtain an adequate level of magnetization in the tube in accordance with 8.3.1 and 8.3.2. This is the *minimum* degree of magnetization required for the successful examination of the type and size tube represented by the reference standard.

8.3.1 Adjust the eddy-current system sensitivity such that without the application of the external magnetization field the examination of the reference standard results in excessive “noise.” This condition is characterized by repeated alarms from the instrument over the entire length of the tube.

8.3.2 On repeated examinations of the reference standard, increase the magnetizing current or the magnetic field to the

point where no further reduction in the tube “noise” is obtained from a further increase in magnetizing field strength.

NOTE 3—It should be pointed out that there is sometimes a false indication of saturation that can result in acceptance of a false saturation level (Fig. 3).

8.4 Adjust the apparatus to obtain an optimum signal-to-noise ratio by adjusting for the minimum sensitivity required to reliably detect the artificial discontinuities in the reference standard. This shall be performed under conditions (such as testing speed) identical to those to be used in the production examination of the tubular products if the system is influenced by these conditions.

8.5 While performing 8.4, or as a separate operation, rotate the calibration standard in either 90 or 120° increments to determine the location of the “electrical” center in the examining coil. Mechanically adjust the position of the tube within the coil to obtain nearly equal responses from the artificial discontinuities regardless of their circumferential location.

8.5.1 Determine the electrical center of a probe coil with respect to the probe field-to-material normality and uniform circumferential lift-off. Adjust the probe field-to-material normality such that uniform signals are obtained from the calibration notches or holes regardless of their position within the intended examination area under the probe. This adjustment is typically encountered when a probe is scanned along a line such as a weld zone.

8.5.2 Establish electrical centering of a rotating probe by adjusting the apparatus to obtain uniform signals from the calibration notches or holes when positioned at 0, 90, 180, and 270°. This adjustment is typically accomplished by ensuring uniform probe lift-off around the circumference of the tube.

8.6 The extent of end effect (Note 4) is determined by using a special reference tube containing a series of similar notches or holes near one or both of the ends (Fig. 4). To evaluate the end effect when notches or holes are placed near only one of the ends, pass the tube through the system twice, once each with the notches or holes at the leading and trailing ends. When the notches or holes are located on the front end of the tube, then the end effect region, or the region of inadequate examination, extends from the front end of the tube to the point where the first of the holes or notches are detected with uniform response. When the holes or notches are on the last end through the system, then the end effect region for that end extends from the point at which the last hole or notch is detected with uniform response to the end of the tube.

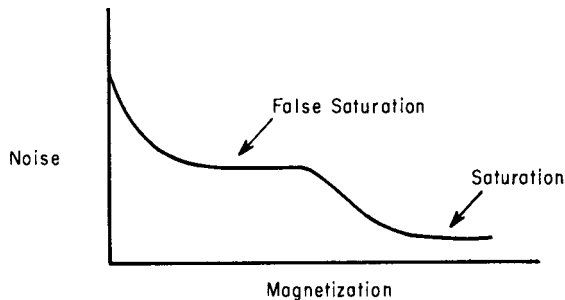

FIG. 3 Graph Depicting “False Saturation” Level Sometimes Encountered when Magnetically Saturating the Material under Test

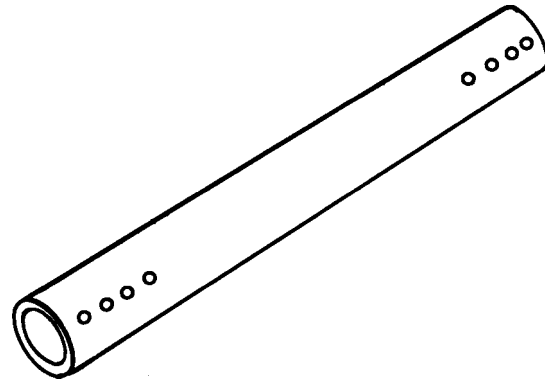

FIG. 4 Location of Artificial Discontinuities (Drilled Holes) that Can Be Used to Determine the Extent of End Effect (The typical distance from the tube end and between each hole is ¼ in. (6.35 mm).)

NOTE 4—It is intended that the extent of the end effect region be determined only once for each specific diameter, gage, speed, coil configuration, and test frequency, and need not be repeated for each run or during the periodic calibration checks.

9. Procedure

9.1 Calibrate the system at the start and end of each run and at the beginning of each shift (or turn) using the reference standard.

9.2 Pass the tubes to be tested through the encircling coil, or past the probe coil, with the apparatus adjusted in accordance with Section 8. Tubes that produce output signals not conforming to the limits in the purchase order or other agreed upon specifications may at the option of the manufacturer be set aside for re-examination. If upon re-examination the output signals are within acceptable limits, or are demonstrated by other examination to be irrelevant, the tubes shall be accepted.

9.3 Tubes may be examined in the final drawn, annealed, heat-treated, or as-welded condition, or at the point specified in the purchase specification. The point in processing at which the examination is made should be agreed upon by the supplier and the purchaser. The tubes shall be free of foreign substances that could interfere with the effectiveness of the examination.

10. Typical Sizes of Artificial Discontinuities

10.1 Longitudinal Notches—Longitudinal notch depth is usually specified as a percentage of nominal wall thickness and values of 10, 12½, or 20 % are typical. Longitudinal notch width is a relevant variable for eddy-current testing and should be specified. Notch length is usually specified in the form of a maximum dimension. Maximum notch lengths of ¼, ½ and 1.0 in. are typical.

10.2 Transverse Notches—Transverse notch depth is measured at the deepest point and is usually specified as a percentage of nominal wall thickness. Values of 10, 12½, and 20 % are typical. Transverse notch width is a relevant variable for eddy-current testing and is typically specified as follows: “The width of the transverse notches shall be the minimum practical but not more than ¼16 in.”

10.3 Holes—When holes are used for calibration, they are usually drilled all the way through one wall of the tube. The diameter of these holes may be specified as a percentage of

wall thickness, or arbitrary sizes may be chosen based on factors involving intended service or other appropriate criteria. Typical hole diameters range from 20 to 50 % of the nominal tube wall thickness; although a 1/16-in. diameter hole is specified for use with all sizes of tubing in one widely used industrial standard. It is considered good practice to include holes with diameters greater and smaller than the reference size used to set the reject level since these provide a useful means of verifying that the dynamic response of the equipment is adequate.

11. Precautionary Information

11.1 Since the density of eddy currents decreases nearly exponentially as the distance from the external surface increases, the response to deep-seated discontinuities decreases. Correspondingly, discontinuity orientation also affects the system response and should be taken into consideration when establishing the examination sensitivity.

11.2 In preparing a reference standard for welded tubing, artificial discontinuities should be placed in both the weld

metal and the parent metal when the responses are expected to be different and if both are to be examined. The apparatus is then adjusted to obtain an optimum signal-to-noise ratio.

11.2.1 When examining only the weld area, the discontinuities shall be placed only in the weld area.

11.3 The examination frequency and the type of apparatus being used should be considered when choosing the examining speed. Certain types of equipment are effective only over a given speed range; therefore, the examining speed should fall within this range.

11.4 Discontinuities such as scratches or seams that are continuous and uniform over the full length of the tube may not always be detected with differential encircling coils or probes scanned along the tube length.

12. Keywords

12.1 discontinuity; encircling coil; ferromagnetic pipe; ferromagnetic tubing; magnetic saturation system; magnetizing field strength; probe coil; tube; tubular product

The American Society for Testing and Materials takes no position respecting the validity of any patent rights asserted in connection with any item mentioned in this standard. Users of this standard are expressly advised that determination of the validity of any such patent rights, and the risk of infringement of such rights, are entirely their own responsibility.

This standard is subject to revision at any time by the responsible technical committee and must be reviewed every five years and if not revised, either reapproved or withdrawn. Your comments are invited either for revision of this standard or for additional standards and should be addressed to ASTM Headquarters. Your comments will receive careful consideration at a meeting of the responsible technical committee, which you may attend. If you feel that your comments have not received a fair hearing you should make your views known to the ASTM Committee on Standards, 100 Barr Harbor Drive, West Conshohocken, PA 19428.

This standard is copyrighted by ASTM, 100 Barr Harbor Drive, West Conshohocken, PA 19428-2959, United States. Individual reprints (single or multiple copies) of this standard may be obtained by contacting ASTM at the above address or at 610-832-9585 (phone), 610-832-9555 (fax), or service@astm.org (e-mail); or through the ASTM website (<http://www.astm.org>).