



# Standard Practice for Flux Leakage Examination of Ferromagnetic Steel Tubular Products<sup>1</sup>

This standard is issued under the fixed designation E 570; the number immediately following the designation indicates the year of original adoption or, in the case of revision, the year of last revision. A number in parentheses indicates the year of last reapproval. A superscript epsilon (ε) indicates an editorial change since the last revision or reapproval.

*This standard has been approved for use by agencies of the Department of Defense.*

---

<sup>ε1</sup> NOTE—Editorial changes were made throughout the standard in January 2004.

---

## 1. Scope

1.1 This practice covers the application and standardization of equipment using the flux leakage test method for detection of outer surface, inner surface, and subsurface discontinuities in ferromagnetic steel tubular products (Note 1) of uniform cross section such as seamless and welded tubing.

NOTE 1—The term “tube” or “tubular product” will be used to refer to both pipe and tubing.

1.2 This practice is intended for use on tubular products having outside diameters from approximately ½ to 24 in. (12.7 to 610 mm) with wall thicknesses to ½ in (12.7 mm). These techniques have been used for other sizes, however, and may be so specified upon contractual agreement between the purchaser and the supplier.

1.3 This practice does not establish acceptance criteria; they must be specified by the using parties.

1.4 *This standard does not purport to address the safety concerns, if any, associated with its use. It is the responsibility of the user of this standard to establish appropriate safety and health practices and determine the applicability of regulatory limitations prior to use.*

## 2. Referenced Documents

### 2.1 ASTM Standards:<sup>2</sup>

E 543 Practice for Evaluating Agencies that Perform Non-destructive Testing

E 1316 Terminology for Nondestructive Examinations

### 2.2 Other Documents:

SNT-TC-1A Recommended for Personnel Qualification and Certification of Nondestructive Testing Personnel<sup>3</sup>

ANSI/ASNT CP-189 ASNT Standard for Qualification and Certification of Nondestructive Testing Personnel<sup>3</sup>

NAS-410 NAS Certification and Qualification of Nondestructive Personnel (Quality Assurance Committee)<sup>4</sup>

## 3. Terminology

3.1 Definitions of terms relating to flux leakage examination are provided in Terminology E 1316.

## 4. Summary of Practice

4.1 This method consists of the following steps:

4.1.1 The tube wall is magnetized at the area under examination to a proper level approaching magnetic saturation.

NOTE 2—Tubes subjected to magnetic inspections can retain various strengths and configuration of residual magnetic fields depending upon the magnetization technique. If the residual field resulting from a given technique can interfere with subsequent applications of the tube, then a supplemental demagnetization process may be required.

4.1.2 A flux sensor containing magnetic transducers is placed on or above the outside surface of the tube in the magnetized area.

4.1.3 Either the tube or the flux sensor is moved at a constant speed in the direction of the magnetic field so that the sensor scans the entire surface of the tube.

---

<sup>1</sup> This practice is under the jurisdiction of ASTM Committee E07 on Nondestructive Testing and is the direct responsibility of Subcommittee E07.07 on Electromagnetic Method.

Current edition approved January 1, 2004. Published February 2004. Originally approved in 1976. Last previous edition approved in 1997 as E 570 - 97.

<sup>2</sup> For referenced ASTM standards, visit the ASTM website, www.astm.org, or contact ASTM Customer Service at service@astm.org. For *Annual Book of ASTM Standards* volume information, refer to the standard's Document Summary page on the ASTM website.

---

<sup>3</sup> Available from The American Society for Nondestructive Testing (ASNT), P.O. Box 28518, 1711 Arlingate Ln., Columbus, OH 43228-0518.

<sup>4</sup> Available from Aerospace Industries Association of America, Inc., 1250 Eye St., NW, Washington, DC 20005.

4.1.4 Each magnetic transducer in the flux sensor is connected to an electronic console which amplifies, filters, and electronically processes the signals such that significant discontinuities are indicated (visually, audibly), and marked with paint, or automatically removed from the production line, or both.

4.1.5 A suitable means for assuring near magnetic saturation of the product (subject to periodic check or calibration) must be provided as part of the examination to verify the capability of detection of outside diameter and inside diameter discontinuities.

## 5. Significance and Use

5.1 This practice outlines a procedure for examining ferromagnetic tubular products using the flux leakage method. If properly applied, this method is capable of detecting the presence and location of significant longitudinally or transversely oriented discontinuities such as pits, scabs, slivers, gouges, roll-ins, laps, seams, cracks, holes, and improper welds in ferromagnetic tubes under inspection. In addition, the severity of a discontinuity may be estimated and a rejection level set with respect to the magnitude of the electromagnetic indication produced by the discontinuity.

5.2 The response from natural discontinuities can be significantly different from the response for artificial discontinuities such as drilled holes or notches of equivalent depth. For this reason, sufficient work should be done to determine the conditions necessary to detect and mark *natural* discontinuities whose characteristics will adversely affect the serviceability of the tube, in order to establish acceptance criteria between the supplier and purchaser.

## 6. Basis of Application

6.1 The following criteria may be specified in the purchase specification, contractual agreement, or elsewhere, and may require agreement between the purchaser and supplier:

6.1.1 Acceptance criteria.

6.1.2 Type, dimensions, location, and number of artificial discontinuities to be placed on the reference standard.

6.1.3 Size and type of tubing to be examined.

6.1.4 Extent of examination (that is, full length, weld zone only if welded, etc.).

6.1.5 Disposition of material with discontinuity indications.

6.1.6 Methods of verifying dimensions of artificial discontinuities and allowable tolerances.

6.1.7 Time of inspection, that is, the point(s) in the manufacturing process at which the material will be inspected.

6.1.8 Nondestructive testing (NDT) personnel shall be qualified in accordance with a nationally recognized NDT personnel qualification practice or standard such as ANSI/ASNT CP-189, SNT-TC-1A, MIL-STD-410, NAS-410, or a similar document. The practice or standard used and its applicable revision shall be specified in the purchase specification or contractual agreement between the using parties.

NOTE 3—MIL-STD-410 is canceled and has been replaced with NAS-410, however, it may be used with agreement between contracting parties.

6.1.9 If specified in the purchase specification or contractual agreement, NDT agencies shall be evaluated and qualified as

described in Practice E 543. The applicable edition of Practice E 543 shall be identified in the purchase specification or contractual agreement between the using parties.

## 7. Interferences

7.1 There are some manufacturing processes that produce tubing with surface conditions that could interfere with or obscure signals related to inner surface discontinuities. In the examination of heavy-walled tubing having these conditions, the ability to examine reliably for inner surface discontinuities may be affected.

7.2 When examining tubes with large rapid surface variations, false signals may be caused by the sensors bouncing along the surface of the tubes.

7.3 For active pole magnetizing systems, a small air gap between the magnetizing system and material under examination could cause a heavy accumulation of scale buildup on the pole pieces.

## DETECTION OF LONGITUDINAL DISCONTINUITIES

## 8. Apparatus

8.1 *Rotary Mechanism*—The rotary mechanism shall be capable of rotating a magnetizing system or flux leakage sensors, or both, in unison around tubing that is being translated axially through the mechanism, thereby producing a helical scan over the surface. Good examination practices require that the pole pieces of the magnetizing system rotate uniformly about the tube and that the flux sensor ride on the tube or be spaced uniformly above the surface of the tube during rotation.

8.2 *Spin Feed Mechanism*—The spin feed mechanism shall be capable of positioning a magnetizing system or flux leakage sensors, or both, on or near the surface of a translating rotating tube such that there is a uniform spacing between the pole pieces of the magnetizing system and the tube. The flux leakage sensors shall ride on the surface of the tube or be held uniformly from the surface of the tube during examination.

8.3 *Magnetizing System*:

8.3.1 An active field magnetizing system consists of a suitable means of applying a strong adjustable transverse magnetic field to the region of the tube under the flux sensors and shall be capable of bringing that region of the tube to near saturation. Typical systems employ either permanent magnets or controllable electromagnets. If permanent magnets are used, a means shall be provided to adjust the spacing of the pole pieces in order to reach the proper magnetization level. Refer to Section 13 for application of longitudinal magnetic fields.

8.3.2 A residual field magnetizing system consists of a means of applying a circular residual magnetic field to an entire tube before the tube is inspected. Typical systems employ a centrally positioned conducting rod through which a high direct current is passed; alternatively, the current may be conducted through the tube itself. The current produces a circular active magnetic field which is concentric with the current distribution. When the current ceases, there remains a residual magnetic field which is circular, concentric with the tube, and wholly contained within the tube wall.

#### 8.4 Flux Leakage Sensors:

8.4.1 The flux sensor shall consist of magnetic field transducers that respond to variations in magnetic flux density. These sensors generally consist of one of the following types: electromagnetic coils, Hall probes, magneto diodes, magnitors, or magnetoresistors. These sensors are normally used to detect the flux leakage directly from the discontinuity in the tube; however, they may also be used to detect flux leakage patterns that have been transferred from the tube to a strip of magnetic tape. The flux sensors should be of sufficient number and length so as to provide 100 % coverage while scanning the tube surface to be examined at the desired examination speed. Their location (with respect to the magnetic pole pieces and the tubular product) should result in maximum response to the leakage field caused by a discontinuity in the tubular product.

8.4.2 The depth and orientation of a discontinuity below the outside surface will affect the magnitude of the signal received from it. Sensitivity decreases significantly as the distance between the flux leakage sensor and the tube under examination is increased. Therefore, the sensors should remain clean and have uniform contact with the tube surface, or if air riding the sensors should be held at a uniform distance above the surface of the tube.

8.5 *Electronic Instrumentation*—The electronic apparatus shall be capable of amplifying signals from the flux sensors and processing them for the operation of alarms. Multiple probes may be used to increase the speed of examination. The signals may be processed in two separate channels to result in a differentiation between inner and outer surface discontinuities. Each of the two sets of electronic channels should contain its own sensitivity and threshold triggering controls for independent setting of percentage of wall rejection levels.

8.6 *Driving Mechanism*—A mechanical drive mechanism shall be used which is capable of rigidly holding and passing the tube through the inspection apparatus at constant speed and concentric with the inspection apparatus. As required, the driving mechanism shall be capable of rotating and advancing, or just advancing the tube with a constant speed.

### 9. Principles of Examination

9.1 Conduct the examination of tubular products for longitudinal discontinuities employing a transverse magnetic field and flux leakage detectors using one or more of the following techniques:

9.1.1 Obtain a transverse magnetic field by either (1) positioning north and south poles of a magnet on opposite sides of a tube on a diameter or chord as shown in Fig. 1(a) and 1(b); or (2) passing a high direct current through a conducting rod centrally positioned in the tube under examination.

9.1.2 Position a flux sensor (or sensors) containing magnetic field transducers on or near the tube surface and move at a uniform speed over the area being magnetized.

9.1.3 At a discontinuity in the tube wall, the flux lines are distorted, producing a leakage field. The maximum flux leakage for a discontinuity normally occurs when magnetization is perpendicular to the discontinuity.

9.1.4 For active pole magnetization, rotation of the magnetizing system about the tube results in transverse magnetization of the tube wall that is periodically perpendicular to all radii of

the tube (Fig. 2(a)). Rotation of the tube with the magnetizing poles held stationary will also produce the same effect (Fig. 2(b)).

9.1.5 Relative motion between the flux sensor and the flux leakage field caused by the discontinuity is generally utilized to generate a voltage in the flux sensor. The amplitude of the voltage generated by the sensor is generally indicative of the severity of the discontinuity when all other factors are constant. The flux leakage field measured at the outside surface of the tube resulting from an inside surface discontinuity is much broader than the leakage field from a discontinuity of equal severity located on the outer surface of the tube, resulting in a lower signal frequency for the inner surface discontinuity (Fig. 3(a) and 3(b)). Several types of equipment utilize this information to determine whether the discontinuity is located on the inner or outer surface of the tube.

9.1.6 Near saturation is required to provide repeatable and reliable indications for the presence of outer surface, inner surface, or subsurface discontinuities. A suitable measuring means or reference samples or both are required to properly adjust the equipment for operation at the required sensitivity and magnetization level.

9.2 The examination of tubular products for transverse discontinuities utilizing a longitudinal magnetic field is discussed in Section 14.

### 10. Reference Standard

10.1 The tubes selected for reference standards should be first examined to ascertain that they are free of interfering natural discontinuities prior to the introduction of artificial defects. The standard tube shall be of the same alloy, temper, and nominal dimensions as the tubes to be examined on a production basis. The standard shall be of sufficient length to permit the required spacing of artificial discontinuities and to be mechanically stable while in the examining position in the apparatus. Artificial discontinuities placed in the tube shall be of the following types:

10.1.1 *Notches*—Longitudinal outside surface or inside surface notches may be produced either by air abrasive, milling, or EDM (Electric Discharge Machining). Notch depth is usually specified as a percent of nominal wall thickness with typical values being 5, 10, 12½, or 20 %. Notch width shall be the minimum practical but shall not exceed the depth. Notch width and geometry are relevant variables that can affect signal response and should be taken into consideration in applying this method. Maximum notch length shall be specified. Lengths of ¼, ½, and 1 in. (6.3, 12.7, and 25.4 mm) are typical. Notch orientation may be longitudinal or at an angle that is typical of the discontinuities produced by the particular manufacturing process. Refer to Section 15 for transverse notches.

10.1.2 *Holes*—When holes are used for calibration, they should be made through the tube wall without causing permanent distortion of the tube. The diameter of these holes may be specified based on factors involving intended service or other appropriate criteria. Typical hole diameters range from ⅓<sub>32</sub> through ⅛ in. (0.79 through 3.2 mm), although a ⅓<sub>16</sub>-in. (1.6-mm) diameter hole is specified for use with all sizes of tube and tubing in one widely used industrial standard. It is considered good practice to include holes with diameters

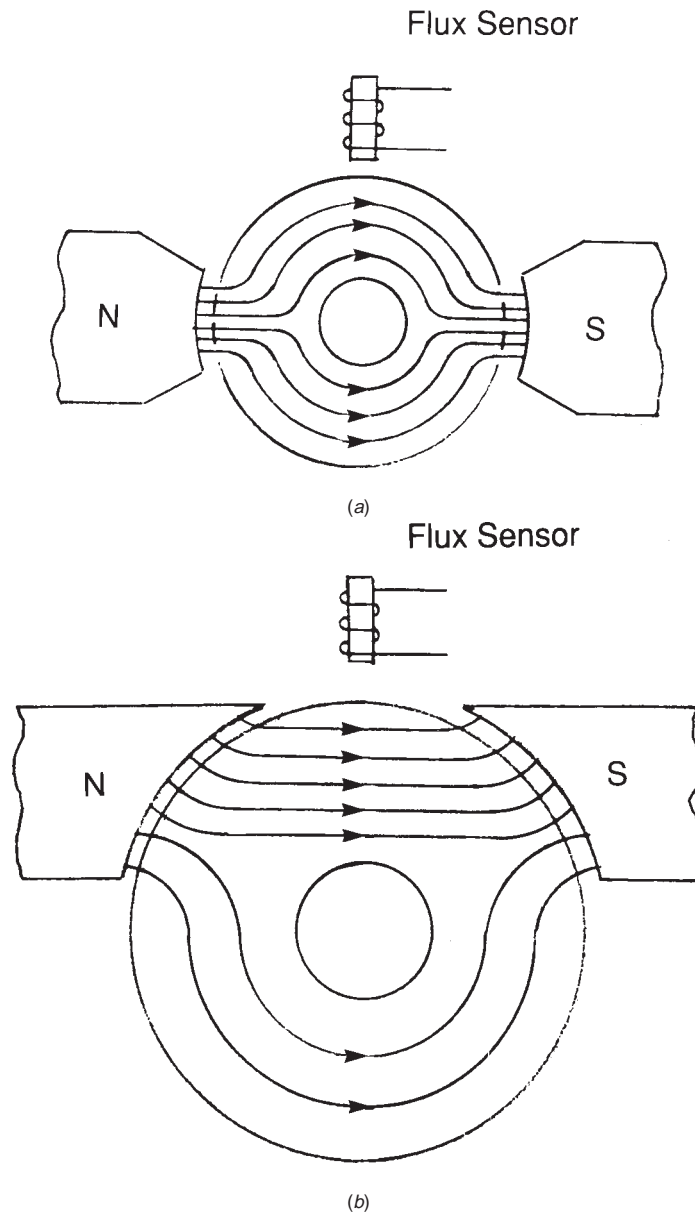

FIG. 1 Transverse Magnetization

greater and smaller than the reference size used to set the rejection level, since these provide a useful means of verifying adequate dynamic response of the equipment.

10.1.3 *Hole and Notch Combination*—Hole size and notch configuration (type, orientation, and dimension, etc.) influence the levels of flux leakage signal response. Correlation between these signals plus the method and tolerances used in their measurement, shall be as specified in the agreement between the supplier and the purchaser.

10.2 In preparing a reference standard for welded tubes, artificial discontinuities should be placed in both the weld metal and the parent metal, if both are to be examined. When inspecting only the weld area, the discontinuities need be placed only in the weld area of the reference standard.

## 11. Adjustment and Standardization of Apparatus Sensitivity

11.1 The procedure for setting up and checking the sensitivity of the apparatus is as follows:

11.1.1 Fabricate the reference standard as specified in the agreement between purchaser and supplier.

11.1.2 Adjust the magnetizing system for the size material to be inspected.

11.1.3 Center the sensing apparatus to properly receive the material to be examined.

11.1.4 Scan the reference standard (containing reference notches or holes or both) and adjust magnetization power, flaw channel sensitivity, and filter network as applicable for optimal

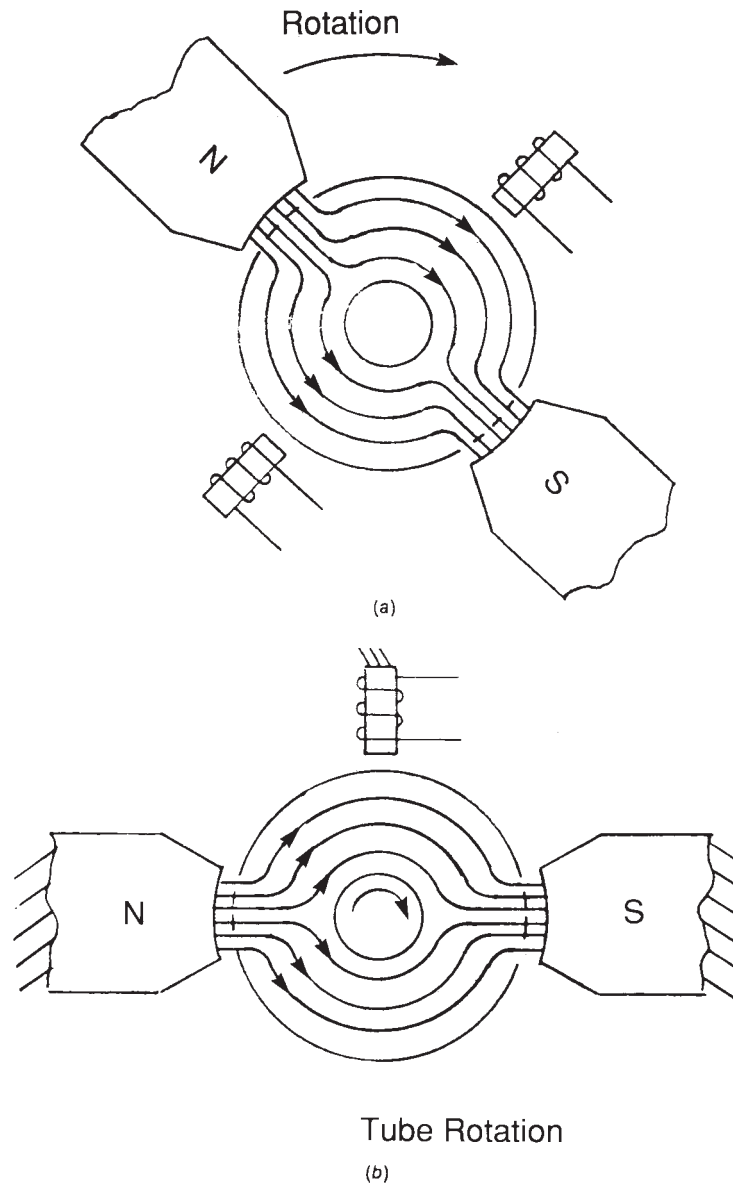

**FIG. 2 Rotational Transverse Magnetization**

signal-to-noise ratio. The tube is normally not translated (advanced) during standardization but all other conditions are identical to those used in production inspection of the tubular product. After standardization, pass the reference standard through the inspection assembly at operating speed to demonstrate adequate performance.

11.1.5 Pass the tubes to be examined through the inspection apparatus with the sensitivity adjusted as described above. Set aside tubes with discontinuity indications indicated by the apparatus. It is recommended that all such tubes be reexamined in accordance with the purchase specification to determine the acceptability of the tube under the applicable specifications.

11.1.6 Standardize the examination apparatus at the start and end of each examination run using the reference standard.

Restandardize at least every 4 h, or whenever improper functioning of the apparatus is suspected. Whenever improper functioning is found, restandardize the apparatus and reexamine all tubes examined during the period since the last proper standardization took place.

11.1.7 Select the examination speed so as to provide assurance of detecting the minimum length discontinuity prescribed in the specification.

## DETECTION OF TRANSVERSE DISCONTINUITIES

### 12. Summary

12.1 The following sections define and clarify portions of Sections 8, 9, 10, and 11 in regard to the examination of tubular

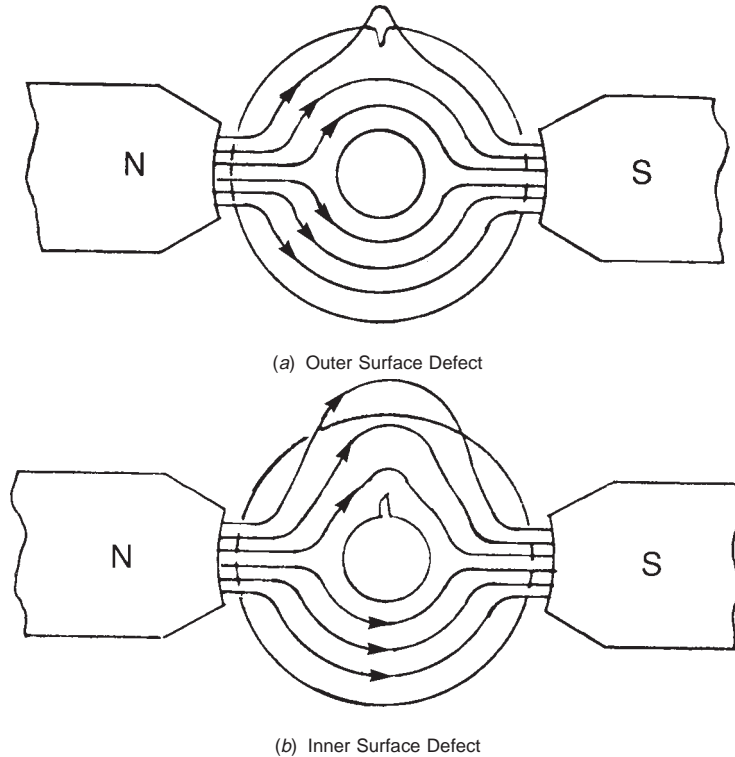

FIG. 3 External Flux Leakage for O.D. and I.D. Discontinuities

products for transversely oriented discontinuities by employing a longitudinal magnetic field.

### 13. Apparatus

13.1 The magnetizing system shall consist of a suitable means of applying a strong adjustable longitudinal magnetic field to the region of the tube under the flux sensors, and shall be capable of bringing that region of the tube to near saturation.

### 14. Principles of Examination

14.1 Conduct the examination of tubular products for discontinuities employing a longitudinal magnetic field and flux leakage detectors using one or more of the following techniques:

14.1.1 Obtain a longitudinal field as shown in Fig. 4(a) by either (1) positioning north and south poles of a magnet on a sector of a tube; or (2) passing a direct current through encircling coils centrally positioned about the tube under examination.

14.1.2 Position a flux sensor (or sensors) containing magnetic field transducers on or near the tube surface which is magnetized as the tube moves through the magnetizing system.

14.1.3 Passing the tube under examination through the magnetizing system results in magnetization of the tube wall that is longitudinal to the axis of the tube under examination.

### 15. Reference Standard

15.1 Dimensions of notches and holes remain the same as covered by Section 10; however, notches should be produced transverse to the axis of the tube.

### 16. Adjustment and Standardization of Apparatus Sensitivity

16.1 Select the proper coils, magnetizing yokes, or permanent magnets where required and follow procedures in Section 11.

### 17. Keywords

17.1 electromagnetic (eddy current) testing; ferromagnetic; flux leakage; NDT; nondestructive testing; steel; tubular products

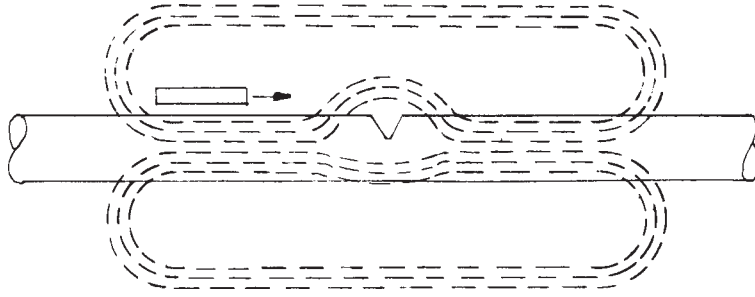

**FIG. 4 Longitudinal Magnetization**

*ASTM International takes no position respecting the validity of any patent rights asserted in connection with any item mentioned in this standard. Users of this standard are expressly advised that determination of the validity of any such patent rights, and the risk of infringement of such rights, are entirely their own responsibility.*

*This standard is subject to revision at any time by the responsible technical committee and must be reviewed every five years and if not revised, either reapproved or withdrawn. Your comments are invited either for revision of this standard or for additional standards and should be addressed to ASTM International Headquarters. Your comments will receive careful consideration at a meeting of the responsible technical committee, which you may attend. If you feel that your comments have not received a fair hearing you should make your views known to the ASTM Committee on Standards, at the address shown below.*

*This standard is copyrighted by ASTM International, 100 Barr Harbor Drive, PO Box C700, West Conshohocken, PA 19428-2959, United States. Individual reprints (single or multiple copies) of this standard may be obtained by contacting ASTM at the above address or at 610-832-9585 (phone), 610-832-9555 (fax), or service@astm.org (e-mail); or through the ASTM website (www.astm.org).*