



■ Designation: **E 709 – 9501**

An American National Standard

Standard Guide for Magnetic Particle Examination¹

This standard is issued under the fixed designation E 709; the number immediately following the designation indicates the year of original adoption or, in the case of revision, the year of last revision. A number in parentheses indicates the year of last reapproval. A superscript epsilon (ϵ) indicates an editorial change since the last revision or reapproval.

This standard has been approved for use by agencies of the Department of Defense.

■ ¹ This guide is under the jurisdiction of ASTM Committee ~~E-7~~ E07 on Nondestructive Testing and is the direct responsibility of Subcommittee E07.03 on Magnetic Particle and Penetrant Testing.

■ Current edition approved ~~March 15, 1995~~, July 10, 2001. Published ~~May 1995~~, September 2001. Originally published as E 709 – 80. Last previous edition E 709 – 945.

1. Scope

1.1 This guide² describes techniques for both dry and wet magnetic particle examination, a nondestructive method for detecting cracks and other discontinuities at or near the surface in ferromagnetic materials. Magnetic particle examination may be applied to raw material, semifinished material (billets, blooms, castings, and forgings), finished material and welds, regardless of heat treatment or lack thereof. It is useful for preventive maintenance examination.

1.1.1 This guide is intended as a reference to aid in the preparation of specifications/standards, procedures and techniques.

1.2 This guide is also a reference that may be used as follows:

1.2.1 To establish a means by which magnetic particle examination, procedures recommended or required by individual organizations, can be reviewed to evaluate their applicability and completeness.

1.2.2 To aid in the organization of the facilities and personnel concerned in magnetic particle examination.

1.2.3 To aid in the preparation of procedures dealing with the examination of materials and parts. This guide describes magnetic particle examination techniques that are recommended for a great variety of sizes and shapes of ferromagnetic materials and widely varying examination requirements. Since there are many acceptable differences in both procedure and technique, the explicit requirements should be covered by a written procedure (see Section 21).

1.3 This guide does not indicate, suggest, or specify acceptance standards for parts/pieces examined by these techniques. It should be pointed out, however, that after indications have been produced, they must be interpreted or classified and then evaluated. For this purpose there should be a separate code, specification, or a specific agreement to define the type, size, location, degree of alignment and spacing, area concentration, and orientation of indications that are unacceptable in a specific part versus those which need not be removed before part acceptance. Conditions where rework or repair are not permitted should be specified.

1.4 This guide describes the use of the following magnetic particle method techniques.

1.4.1 Dry magnetic powder (see 8.34),

1.4.2 Wet magnetic particle (see 8.45),

1.4.3 Magnetic slurry/paint magnetic particle (see 8.45.8), and

1.4.4 Polymer magnetic particle (see 8.45.8).

1.5 *Personnel Qualification*—Personnel performing examination ~~is in accordance with~~ this guide shall be qualified and certified in accordance with ~~ASNT Qualification and Certification of NDT Personnel, or Recommended Practice No. SNT-TC-1A, or MIL-STD-410 for military purposes, ANSI/ASNT Standard CP-189, NAS 410,~~ or as specified in the contract or purchase order.

1.6 *Nondestructive Testing Agency*— If a nondestructive testing agency as described in Practice E 543 is used to perform the examination, the testing agency shall meet the requirements of Practice E 543.

1.7 Table of Contents:

	SECTION
Scope	1
Scope Description	1.1
A Reference Document	1.2
Acceptance Standards for Parts not Covered	1.3
Magnetic Particle Method Techniques	1.4
Personnel Qualifications	1.5
Nondestructive Testing Agency	1.6
Table of Contents	1.7
SI Units	1.8
Safety Caveat	1.9
Referenced Documents	2
ASTM Standards	2.1
SAE Documents	2.2
ASNT Documents	2.3
U.S. Government Documents	2.4
Definitions	3
Summary of Guide	4
Principle	4.1
Method	4.2
Magnetization	4.3
Types of Magnetic Particle and Their Use	4.4
Evaluation of Indications	4.5
Typical Magnetic Particle Indications	4.6
Significance and Use	5
Equipment	6
Types	6.1
	SECTION
Portability	6.2

² For ASME Boiler and Pressure Vessel Code Applications see related Guide SE-709 in Section II of that Code.

Yokes	6.3
Prods	6.4
Black Light	6.5
Equipment Verification	6.6
Examination Area	7
Light Intensity for Examination	7.1
Housekeeping	7.2
Magnetic Particle Materials	8
Particle Types	8.1
<u>Particle Types</u>	<u>8.2</u>
Particle Characteristics	8.2
<u>Particle Characteristics</u>	<u>8.3</u>
Dry Particles	8.3
<u>Dry Particles</u>	<u>8.4</u>
Wet Particle Systems	8.4
<u>Wet Particle Systems</u>	<u>8.5</u>
Part Preparation	9
General	9.1
Cleaning Examination Surface	9.2
Sequence of Operations	10
Sequencing Particle Application and Establishing Magnetic Flux Field	10.1
Types of Magnetizing Currents	11
Basic Current Types	11.1
Part Magnetization Techniques	12
Examination Coverage	12.1
Direct and Indirect Magnetization	12.2
Choosing a Magnetization Technique	12.3
Direction of Magnetic Fields	13
Discontinuity Orientation vs Magnetic Field Direction	13.1
Circular Magnetization	13.2
Torodial Magnetization	13.3
Longitudinal Magnetization	13.4
Multidirectional Magnetization	13.5
Magnetic Field Strength	14
Magnetizing Field Strengths	14.1
Establishing Field Strengths	14.2
Guidelines for Establishing Magnetic Fields	14.3
Application of Dry and Wet Magnetic Particles	15
Dry Magnetic Particles	15.1
Wet Particles Applications	15.2
Magnetic Slurry/Paint	15.3
Magnetic Polymers	15.4
Interpretation of Indications	16
Valid Indications	16.1
Recording of Indications	17
Means of Recording	17.1
Accompanying Information	17.2
Demagnetization	18
Applicability	18.1
Demagnetization Methods	18.2
Extent of Demagnetization	18.3
Post Examination Cleaning	19
Particle Removal	19.1
Means of Particle Removal	19.2
Evaluation of System Performance/Sensitivity	20
Contributor Factors	20.1
Maintenance and Calibration of Equipment	20.2
Equipment Checks	20.3
Examination Area Light Level Control	20.4
Dry Particle Quality Control Tests	20.5
Wet Particle Quality Control Tests	20.6
Bath Characteristics Control	20.7
Verifying System Performance	20.8
Procedure and Report	21
Written Procedure	21.1
Written Reports	21.2

Acceptance Standards	22
Safety	23
	SECTION
Precision and Bias	24
Keywords	25
Annex	<u>AnnexA1</u>
<u>Appendix X1.</u>	<u>Appendix</u> <u>X1</u>
<u>Appendix X2.</u>	<u>Appendix</u> <u>X2</u>

1.8 The numerical values shown in inch-pound units are to be regarded as the standard. SI units are provided for information only.

1.9 *This standard does not purport to address all of the safety concerns, if any, associated with its use. It is the responsibility of the user of this standard to establish appropriate safety and health practices and determine the applicability of regulatory limitations prior to use.*

2. Referenced Documents

2.1 ASTM Standards:

A 275/A 275M Test Method for Magnetic Particle Examination of Steel Forgings³

A 456/A 456M Specification for Magnetic Particle Examination of Large Crankshaft³

D 93 Test Methods for Flash Point by Pensky-Martens Closed Tester⁴

D 1296 Test Methods for Water and Sediment Sulfur in Crude Oil by Centrifuge Method (Field Procedure)³ Petroleum Products (General Bomb Method)⁴

D 129 Test 445 Test Method for Sulfur in Petroleum Products (General Bomb Method)³ Kinematic Viscosity of Transparent and Opaque Liquids (and the Calculation of Dynamic Viscosity)⁴

D 445 Test 808 Test Method for Kinematic Viscosity of Transparent Chlorine in New and Opaque Liquids (and the Calculation of Dynamic Viscosity)³ Used Petroleum Products (Bomb Method)⁴

D 808 Test 1966 Test Method for Chlorine Foots in New and Used Petroleum Products (Bomb Method)³ Raw Linseed Oil Gravimetric Method⁵

E 165 Test Method for Liquid Penetrant Examination⁶

E 543 Practice for Evaluating Agencies that Perform Performing Nondestructive Testing⁶

E 1316 Terminology for Nondestructive Examinations⁶

E 1444 Practice for Magnetic Particle Examination⁶

2.2 Society of Automotive Engineers (SAE): Aerospace Materials Specifications:⁷

AMS 2641 Vehicle

AMS 2300 Premium Aircraft Quality Steel Cleanliness Magnetic Particle Inspection Procedure

AMS 2301 Aircraft Quality Steel Cleanliness Magnetic Particle Inspection Procedure

AMS 2303 Aircraft Quality Steel Cleanliness Martensitic Corrosion Resistant Steels Magnetic Particle Inspection Procedure

AMS 2641 Vehicle Magnetic Particle Inspection

AMS 3040 Magnetic Particles, Non-fluorescent, Dry Method

AMS 3041 Magnetic Particles, Non-fluorescent, Wet Method, Oil Vehicle, Ready to Use

AMS 3042 Magnetic Particles, Non-fluorescent, Wet Method, Dry Powder

AMS 3043 Magnetic Particles, Non-fluorescent, Oil Vehicle, Aerosol Packaged

AMS 3044 Magnetic Particles, Fluorescent, Wet Method, Dry Powder

AMS 3045 Magnetic Particles, Non-fluorescent, Wet Method, Oil Vehicle, Ready to Use

AMS 3046 Magnetic Particles, Non-fluorescent, Wet Method, Oil Vehicle, Aerosol Packaged

AMS 5062 Steel, Low Carbon Bars, Forgings, Tubing, Sheet, Strip, and Plate 0.25 Carbon, Maximum

AMS 5355 Investment Castings

AMS-I-83387 Inspection Process, Magnetic Rubber

AS 4792 Water Conditioning Agents for Aqueous Magnetic Particle Inspection

AS 5282 Tool Steel Ring Standard for Magnetic Particle Inspection

³ Annual Book of ASTM Standards, Vol 05.01: 01.05.

⁴ Annual Book of ASTM Standards, Vol 03.03: 05.01.

⁵ Available from Society

⁶ Annual Book of Automotive Engineers, 400 Commonwealth Drive, Warrendale, PA 15096; ASTM Standards, Vol 06.03.

⁶ Available from American Society for Nondestructive Testing, 1711 Arlingate Plaza, P.O. Box 28518, Columbus, OH 43228-0518.

⁶ Annual Book of ASTM Standards, Vol 03.03.

⁷ Available from Standardization Documents Order Desk, Bldg. 4 Section D, 700 Robbins Ave., Philadelphia, Society of Automotive Engineers, 400 Commonwealth Drive, Warrendale, PA 15111-5094, Attn: NPODS: 15096.

AS 5371 Reference Standards Notched Shims for Magnetic Particle Inspection

2.3 American Society for Nondestructive Testing:⁸

SNT-TC-1A Recommended Practice Magnetic Particle Method

CP-189 ASNT Qualification and Certification of Nondestructive Testing Personnel

2.4 U.S. Government Publications: Federal Standards:⁹

A-A-59230 Fluid, Magnetic Particle Inspection, Suspension

FED-STD 313 Material Safety Data Sheets Preparation and the Submission of

MIL-STD-410 Nondestructive Testing Personnel Qualification and Certification

MIL-STD-1949 Magnetic Particle Inspection, Method of

2.5 OSHA Document:¹⁰

29CFR 1910.1200 Hazard Communication

2.6 AIA Documents:

NAS 410 Nondestructive Testing Personnel Qualification and Certification

3. Terminology

3.1 For definitions of terms used in the practice, refer to Terminology E 1316

4. Summary of Guide

4.1 *Principle*—The magnetic particle method is based on the principle that magnetic field lines when present in a ferromagnetic material, will be distorted by a change in material continuity, such as a sharp dimensional change or a discontinuity. If the discontinuity is open to or close to the surface of a magnetized material, flux lines will be distorted at the surface, a condition termed as “flux leakage.” When fine magnetic particles are distributed over the area of the discontinuity while the flux leakage exists, they will be held in place and the accumulation of particles will be visible under the proper lighting conditions. While there are variations in the magnetic particle method, they all are dependent on this principle, that magnetic particles will be retained at the locations of magnetic flux leakage.

4.2 *Method*—While this practice permits and describes many variables in equipment, materials, and procedures, there are three steps essential to the method:

4.2.1 The part must be magnetized.

4.2.2 Magnetic particles of the type designated in the contract/purchase order/specification must be applied while the part is magnetized.

4.2.3 Any accumulation of magnetic particles must be observed, interpreted, and evaluated.

4.3 *Magnetization:*

4.3.1 *Ways to Magnetize*—A ferromagnetic material can be magnetized either by passing an electric current through the material or by placing the material within a magnetic field originated by an external source. The entire mass or a portion of the mass can be magnetized as dictated by size and equipment capacity or need. As previously noted, the discontinuity must interrupt the normal path of the magnetic field lines. If a discontinuity is open to the surface, the flux leakage will be at the maximum for that particular discontinuity. When that same discontinuity is below the surface, flux leakage evident on the surface will be less. Practically, discontinuities must be open to the surface, to create sufficient flux leakage to accumulate magnetic particles.

4.3.2 *Field Direction*—If a discontinuity is oriented parallel to the magnetic field lines, it may be essentially undetectable. Therefore, since discontinuities may occur in any orientation, it may be necessary to magnetize the part or area of interest twice or more sequentially in different directions by the same method or a combination of methods (see Section 13) to induce magnetic field lines in a suitable direction in order to perform an adequate examination.

4.3.3 *Field Strength*—The magnetic field must be of sufficient strength to indicate those discontinuities which are unacceptable, yet must not be so strong that an excess of particles is accumulated locally thereby masking relevant indications (see Section 14).

4.4 *Types of Magnetic Particles and Their Use*—There are various types of magnetic particles available for use in magnetic particle examination. They are available as dry powders (fluorescent and nonfluorescent) ready for use as supplied (see 8.34), powder concentrates (fluorescent and nonfluorescent) for dispersion in water or suspending light petroleum distillates (see 8.45), magnetic slurries/paints (see 8.45.7), and magnetic polymer dispersions (see 8.45.8).

4.5 *Evaluation of Indications*—When the material to be examined has been properly magnetized, the magnetic particles have been properly applied, and the excess particles properly removed, there will be accumulations of magnetic particles at the points of flux leakage. These accumulations show the distortion of the magnetic field and are called indications. Without disturbing the

⁸ Available from Occupational Safety and Health Review Commission, 1825 K Street, N.W., Washington, DC 20006. American Society for Nondestructive Testing, 1711 Arlingate Plaza, P.O. Box 28518, Columbus, OH 43228-0518.

⁹ These equations are included for historical continuity only. It is faster to buy a Tesla meter, lay the probe on the part and measure the field strength than calculating using the equations.

⁹ Available from Standardization Documents Order Desk, Bldg. 4 Section D, 700 Robbins Ave., Philadelphia, PA 19111-5094, Attn: NPODS.

¹⁰ Available from Occupational Safety and Health Review Commission, 1825 K Street, N.W., Washington, DC 20006.

particles, the indications must be examined, classified, interpreted as to cause, compared with the acceptance standards, and a decision made concerning the disposition of the material that contains the indication.

4.6 *Typical Magnetic Particle Indications* :

4.6.1 *Surface Discontinuities*—Surface discontinuities, with few exceptions, produce sharp, distinct patterns (see Annex A1).

4.6.2 *Near-surface discontinuities*—Near-surface discontinuities produce less distinct indications than those open to the surface. The patterns are broad, rather than sharp, and the particles are less tightly held (see Annex A1).

5. **Significance and Use**

5.1 The magnetic particle method of nondestructive examination indicates the presence of surface and near-surface discontinuities in materials that can be magnetized (ferromagnetic). This method can be used for production examination of parts/components or structures and for field applications where portability of equipment and accessibility to the area to be examined are factors. The ability of the method to find small discontinuities can be enhanced by using fluorescent particles suspended in a suitable vehicle and by introducing a magnetic field of the proper strength whose orientation is as close as possible to 90° to the direction of the suspected discontinuity (see 4.3.2). Making the surface smoother improves mobility of the magnetic particles under the influence of the magnetic field to collect on the surface where magnetic flux leakage occurs.

6. **Equipment**

6.1 *Types*—There are a number of types of equipment available for magnetizing ferromagnetic parts and components. With the exception of a permanent magnet, all equipment requires a power source capable of delivering the required current levels to produce the magnetic field. The current used dictates the sizes of cables and the capability of relays, switching contacts, meters and rectifier if the power source is alternating current.

6.2 *Portability*—Portability, which includes the ability to hand carry the equipment, can be obtained from yokes. Their size limits their ability to provide the magnetic fields that can be obtained from equipment with larger current flows. General purpose mobile equipment which may be truck mounted, is usually designed either for use with prods on the ends of two cables or with only the cables which are attached to the piece being examined, threaded through an opening in it or wrapped around it. Mobility is limited by the cable and size and the environment. Underwater examination on oil drilling platforms and oil production platforms offshore are examples of a hostile environment.

6.3 *Yokes*—Yokes are usually C-shaped electromagnets which induce a magnetic field between the poles (legs) and are used for local magnetization (Fig. 1). Many portable yokes have articulated legs (poles) that allow the legs to be adjusted to contact irregular surfaces or two surfaces that join at an angle.

6.3.1 *Permanent Magnets*—Permanent magnets are available but their use may be restricted for many applications. Permanent magnets can lose their magnetic field generating capacity by being partially demagnetized by a stronger flux field, being damaged, or dropped. In addition, the particle mobility, created by AC and half-wave rectified current pulsations in electromagnetic yokes, is not present. Particles, steel filings, chips, and scale clinging to the poles can create a housekeeping problem.

6.4 *Prods*—Prods are used for local magnetizations, see Fig. 2. The prod tips that contact the piece should be aluminum, copper braid, or copper pads rather than solid copper. With solid copper tips, accidental arcing during prod placement or removal can cause copper penetration into the surface which may result in metallurgical damage (softening, hardening, cracking, etc.). See 12.3.1.1(a). Open-circuit voltages should not exceed 25 V.

6.4.1 *Remote Control Switch*—A remote-control switch, which may be built into the prod handles, should be provided to permit the current to be turned on after the prods have been properly placed and to turn it off before the prods are removed in order to minimize arcing (arc burns). (See 12.3.1.1(a).)

6.5 *Black Light*—The black light must be capable of developing the required wavelengths of 330 to 390 nm with an intensity at the examination surface that satisfies 7.1.2. Wavelengths at or near 365 nm shall predominate. Suitable filters should remove

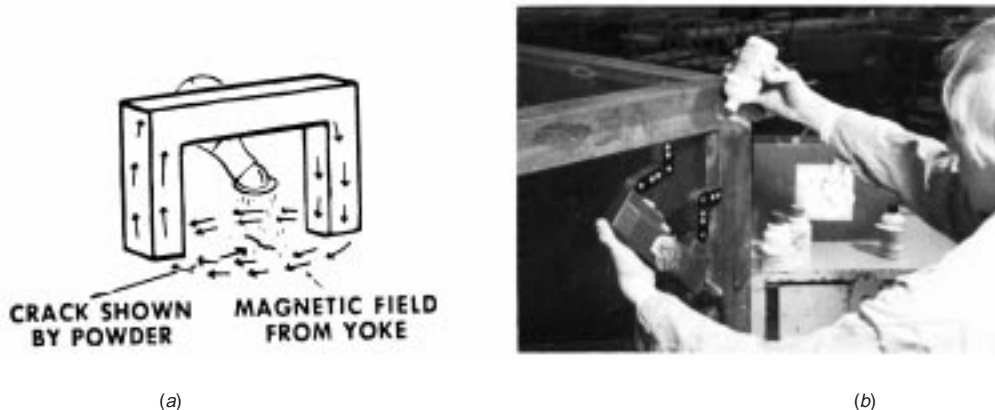
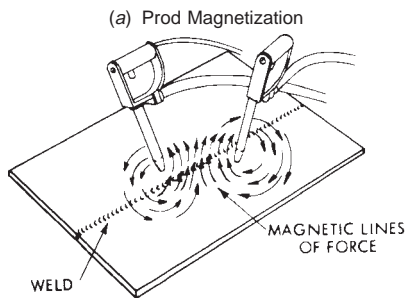
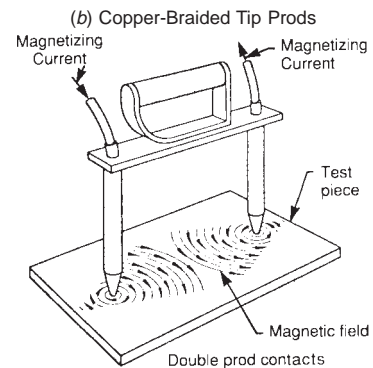

FIG. 1 Yoke Method of Part Magnetization



(c) Single-Prod Contacts Magnetization



(d) Double-Prod Contacts

FIG. 2 Localized Area Magnetization Using Prod Technique

the extraneous visible light emitted by black lights (violet or blue 405 and 435-nm Hg lines and greenish-yellow 577-nm Hg line). Some high-intensity black light bulbs may emit unacceptable amounts of greenish-yellow light which may cause fluorescent indications to become invisible. A drop, greater than 10 %, in line voltage greater than ± 10 % can cause a change in black light output with consequent inconsistent performance. A constant voltage transformer should be used where there is evidence of voltage changes greater than 10 %.

6.6 *Equipment Verification*—See Section 20.

7. Examination Area

7.1 *Light Intensity for Examination*—Magnetic indications found using nonfluorescent particles are examined under visible light. Indications found using fluorescent particles must be examined under black (ultraviolet) light. This requires a darkened area with accompanying control of the visible light intensity.

7.1.1 *Visible Light Intensity*—The intensity of the visible light at the surface of the part/work piece undergoing examination should be a minimum of 100 foot candles (1000 lux). The intensity of ambient visible light in the darkened area where fluorescent magnetic particles examination is performed should not exceed 2 foot candles (20 lux).

7.1.1.1 *Field Inspections*—For some field inspections using nonfluorescent particles, visible light intensities as low as 50 foot candles (500 lux) may be used when agreed on by the contracting agency.

7.1.2 *Black (Ultraviolet) Light:*

7.1.2.1 *Black Light Intensity*—The black light intensity at the examination surface shall be not less than $1000 \mu\text{W}/\text{cm}^2$ when measured with a suitable black light meter.

7.1.2.2 *Black Light Warm-up*—Allow the black light to warm up for a minimum of 5 min prior to its use or measurement of the intensity of the ultraviolet light emitted.

7.1.3 *Dark Area Eye Adaptation*—~~It is recommended that the an inspector be in the darkened area for at least 3 min prior to examining parts using black light one (1) minute so that his/her eyes will adapt to dark viewing prior to examining parts under UV illumination.~~¹¹ **Caution** —Photochromic or permanently tinted lenses ~~shall should~~ not be worn during examination.

¹¹ This guide is under the jurisdiction of ASTM Committee E07 on Nondestructive Testing and is the direct responsibility of Subcommittee E07.03 on Magnetic Particle and Penetrant Testing.

Current edition approved July 10, 2001. Published September 2001. Originally published as E 709 – 80. Last previous edition E 709 – 95.

7.2 *Housekeeping*—The examination area should be kept free of interfering debris. If fluorescent materials are involved, the area should also be kept free of fluorescent objects not related to the part/piece being examined.

8. Magnetic Particle Materials

8.1 *Magnetic Particle Properties* :

8.1.1 *Dry Particle Properties*—AMS 3040 describes the generally accepted properties of dry method particles.

8.1.2 *Wet Particle Properties*—The following documents describe the generally accepted properties of wet method particles in their various forms:

AMS 3041

AMS 3042

AMS 3043

AMS 3044

AMS 3045

AMS 3046

8.1.3 *Suspension Vehicle*—The suspension vehicle for wet-method examination may be either a light oil distillate fluid (refer to AMS 2641 or A-A-52930) or a conditioned water vehicle (refer to AS 4792).

8.2 *Particle Types*—The particles used in either dry or wet magnetic particle examination techniques are basically finely divided ferromagnetic materials which have been treated to impart color (fluorescent and nonfluorescent) in order to make them highly visible (contrasting) against the background of the surface being examined. The particles are designed for use either as a free flowing dry powder or for suspension at a given concentration in a suitable liquid medium.

8.23 *Particle Characteristics*—The magnetic particles must have high permeability to allow ease of magnetizing and attraction to the discontinuity and low retentivity so they will not be attracted (magnetic agglomeration) to each other. Control of particle size and shape is required to obtain consistent results. The particles should be nontoxic, free from rust, grease, paint, dirt, and other deleterious materials that might interfere with their use; see 20.5 and 20.6. Both dry and wet particles are considered safe when used in accordance with the manufacturer's instructions. They generally afford a very low hazard potential with regard to flammability and toxicity.

8.34 *Dry Particles*—Dry magnetic powders are designed to be used as supplied and are applied by spraying or dusting directly onto the surface of the part being examined. They are generally used on an expendable basis although the particles may be collected and reused. However, to maintain particle size and control possible contamination, this is not a normal practice. Dry powders may also be used under extreme environmental conditions. They are not affected by cold; therefore examination can be carried out at temperatures that would thicken or freeze wet baths. They are also heat resistant; some powders may be usable at temperatures up to 600°F (315°C). Some colored, organic coatings applied to dry particles to improve contrast lose their color at temperatures this high, making the contrast less effective. Fluorescent dry particles cannot be used at this high a temperature; the manufacturer should be contacted for the temperature limitation or tests should be run.

8.34.1 *Advantages*—The dry magnetic particle technique is generally superior to the wet technique for detection of near-surface discontinuities: (a) for large objects when using portable equipment for local magnetization; (b) superior particle mobility is obtained for relatively deep-seated flaws half-wave rectified current as the magnetizing source; (c) ease of removal.

8.34.2 *Disadvantages*—The dry magnetic particle technique; (a) cannot be used in confined areas without proper safety breathing apparatus; (b) ~~Probability of Detection (POD) is appreciably less than the wet technique for fine surface discontinuities;~~ (c) ~~can be~~ difficult to use in overhead magnetizing positions; (d) ~~does not always leave evidence exists of complete coverage of part surface as with the wet technique;~~ (e) (d) ~~is likely to have~~ lower production rates ~~can be expected with than~~ the dry technique ~~versus the wet technique;~~ and (f) ~~it~~ (e) is difficult to adapt to any type of automatic system.

8.34.3 *Nonfluorescent Colors*—Although dry magnetic particle powder can be almost any color, the most frequently employed colors are light gray, black, red, or yellow. The choice is generally based on maximum contrast with the surface to be examined. The examination is done under visible light.

8.34.4 *Fluorescent*—Fluorescent dry magnetic particles are also available, but are not in general use primarily because of their higher cost and use limitations. They require a black light source and a darkened work area. These requirements are not often available in the field-type locations where dry magnetic particle examinations are especially suitable.

8.4.5 *Dual Colors*—Dual-colored particles are available that are readily detectable in visible light and also display fluorescence when viewed under ultra-violet light or a combination visible and ultra-violet light. Use in accordance with the manufacturer's recommendations.

8.5 *Wet Particle Systems*—Wet magnetic particles are designed to be suspended in a vehicle such as water or light petroleum distillate at a given concentration for application to the test surface by flowing, spraying, or pouring. They are available in both fluorescent and nonfluorescent concentrates. In some cases the particles are premixed with the suspending vehicle by the supplier, but usually the particles are supplied as a dry concentrate or paste concentrate which is mixed with the distillate or water by the user. The suspensions are normally used in wet horizontal magnetic particle equipment in which the suspension is retained in a reservoir and recirculated for continuous use. The suspension may also be used on an expendable basis dispensed from an aerosol.

8.45.1 *Primary Use*—Because the particles used are smaller, wet method techniques are generally used to locate smaller discontinuities than the dry method is used for. The liquid vehicles used will not perform satisfactorily when their viscosity exceeds

5cSt (5 mm²/s) at the operating temperature. If the suspension vehicle is a hydrocarbon, its flash point limits the top temperature. Mixing equipment is usually required to keep wet method particles uniformly in suspension.

8.45.2 Where Used—The wet fluorescent method usually is performed indoors or in areas where shelter and ambient light level can be controlled and where proper application equipment is available.

8.45.3 Color—~~Fluorescent wet method particles glow a bright greenish-yellow when viewed under black light. Nonfluorescent particles are usually black or reddish brown, although other colors are available. The~~ The color often chosen for any given examination should be one that best contrasts most with the test examination surface. Because contrast is invariably higher with fluorescent materials, these are utilized in most wet process examinations. Fluorescent wet method particles normally glow a bright yellow-green when viewed under black light, although other colors are available. Non-fluorescent particles are usually black or reddish brown, although other colors are available. Dual-colored particles are available that are readily detectable in visible light and also display fluorescence when viewed under ultra-violet light or a combination visible and ultra-violet light. Refer to 8.5.5.

8.45.4 Suspension Vehicles—Generally the particles are suspended in a light petroleum (low-viscosity) distillate or conditioned water. (If sulfur or chlorine limits are specified, use Test Methods D 129 and D 808 to determine their values.

8.45.4.1 Petroleum Distillates—Low-viscosity light petroleum distillates vehicles (AMS 2641 Type 1 or equal) are ideal for suspending both fluorescent and nonfluorescent magnetic particles and are commonly employed.

(1) *Advantages*—Two significant advantages for the use of petroleum distillate vehicles are: (a) the magnetic particles are suspended and dispersed in petroleum distillate vehicles without the use of conditioning agents; and (b) the petroleum distillate vehicles provide a measure of corrosion protection to parts and the equipment used.

(2) *Disadvantages*—Principal disadvantages are flammability and availability. It is essential, therefore, to select and maintain readily available sources of supply of petroleum distillate vehicles that have as high a flash point as practicable to avoid possible flammability problems.

(3) *Characteristics*—Petroleum distillate vehicles to be used in wet magnetic particle examination should possess the following: (a) viscosity should not exceed 3.0 cSt (3 mm²/s) at 100°F (38°C) and not more than 5.0 cSt (5 mm²/s) at the lowest temperature at which the vehicle will be used; when tested in accordance with Test Method D 445, in order not to impede particle mobility (see 20.7.43), (b) minimum flash point, when tested in accordance with Test Methods D 93, should be 200°F (93°C) in order to minimize fire hazards (see 20.7.24), (c) odorless; not objectionable to user, (d) low inherent fluorescence if used with fluorescent particles; that is, it should not interfere significantly with the fluorescent particle indications (see 20.6.4.1), and (e) nonreactive; should not degrade suspended particles.

8.45.4.2 Water Vehicles with Conditioning Agents—Water may be used as a suspension vehicle for wet magnetic particles provided suitable conditioning agents are added which provide proper wet dispersing, in addition to corrosion protection for the parts being tested and the equipment in use. Plain water does not disperse some types of magnetic particles, does not wet all surfaces, and is corrosive to parts and equipment. On the other hand, water suspensions of magnetic particles are safer to use since they are nonflammable. The selection and concentration of the conditioning agent should be as recommended by the particle manufacturer. The following are recommended properties for water vehicles containing conditioning agents for use with wet magnetic particle examination:

(1) *Wetting Characteristics*—The vehicle should have good wetting characteristics; that is, wet the surface to be tested, give even, complete coverage without evidence of dewetting the test surface. Smooth test surfaces require that a greater percentage of wetting agent be added than is required for rough surface. Nonionic wetting agents are recommended (see 20.7.35).

(2) *Suspension Characteristics*—Impart good dispersability; that is, thoroughly disperse the magnetic particles without evidence of particle agglomeration.

(3) *Foaming*—Minimize foaming; that is, it should not produce excessive foam which would interfere with indication formation or cause particles to form scum with the foam.

(4) *Corrosiveness*—It should not corrode parts to be tested or the equipment in which it is used.

(5) *Viscosity Limit*—The viscosity of the conditioned water should not exceed a maximum viscosity of 3 cSt (3 mm²/s) at 100°F (38°C) (see 20.7.43).

(6) *Fluorescence*—The conditioned water should not fluoresce if intended for use with fluorescent particles.

(7) *Nonreactiveness*—The conditioned water should not cause deterioration of the suspended magnetic particles.

(8) *Water pH*—The pH of the conditioned water should not be less than ~~6.0~~ 7.0 or exceed 10.5.

(9) *Odor*—The conditioned water should be essentially odorless.

8.45.5 Concentration of Wet Magnetic Particle Suspension —The initial bath concentration of suspended magnetic particles should be as specified or as recommended by the manufacturer and should be checked by settling volume measurements and maintained at the specified concentration on a daily basis. If the concentration is not maintained properly, ~~test examination results can vary greatly.~~ The concentration of dual-colored particles in the wet method bath suspension may be adjusted to best perform in the desired lighting environment. Higher particle concentration is recommended for visible light areas and lower particle concentration is recommended for ultraviolet light areas. Use in accordance with the particle manufacturer's recommendations.

8.45.6 Application of Wet Magnetic Particles (see 15.2).

8.45.7 Magnetic Slurry/Paint Systems— Another type of examination vehicle is the magnetic slurry/paint type consisting of a

heavy oil in which flake-like particles are suspended. The material is normally applied by brush before the part is magnetized. Because of the high viscosity, the material does not rapidly run off surfaces, facilitating the inspection of vertical or overhead surfaces. The vehicles may be combustible, but the fire hazard is very low. Other hazards are very similar to those of the oil and water vehicles previously described.

8.45.8 *Polymer-Based Systems*—The vehicle used in the magnetic polymer is basically a liquid polymer which disperses the magnetic particles and which cures to an elastic solid in a given period of time, forming fixed indications. Viscosity limits of standard wet technique vehicles do not apply. Care should be exercised in handling these polymer materials. Use in accordance with manufacturer's instructions and precautions. This technique is particularly applicable to examine areas of limited visual accessibility, such as bolt holes.

9. Part Preparation

9.1 *General*—The surface of the part to be examined should be essentially clean, dry, and free of contaminants such as dirt, oil, grease, loose rust, loose mill sand, loose mill scale, lint, thick paint, welding flux/slag, and weld splatter that might restrict particle movement. See 15.1.2 about applying dry particles to a damp/wet surface. When testing a local area, such as a weld, the areas adjacent to the surface to be examined, as agreed by the contracting parties, must also be cleaned to the extent necessary to permit detection of indications.

9.1.1 *Nonconductive Coatings*—Thin nonconductive coatings, such as paint in the order of 0.02 to 0.05 mm (1 or 2 mil) will not normally interfere with the formation of indications, but they must be removed at all points where electrical contact is to be made for direct magnetization. Indirect magnetization does not require electrical contact with the part/piece. See Section 12.2. If a nonconducting coating/plating is left on the area to be examined that has a thickness greater than 0.05 mm (2 mil), it must be demonstrated that discontinuities can be detected through the maximum thickness applied.

9.1.2 *Conductive Coatings*—A conductive coating (such as chrome plating and heavy mill scale on wrought products resulting from hot forming operations) can mask discontinuities. As with nonconductive coatings, it must be demonstrated that the discontinuities can be detected through the coating.

9.1.3 *Residual Magnetic Fields*—If the part/piece holds a residual magnetic field from a previous magnetization that will interfere with the examination, the part must be demagnetized. See Section 18.

9.2 *Cleaning Examination Surface*—Cleaning of the test surface may be accomplished by detergents, organic solvents, or mechanical means. As-welded, as-rolled, as-cast, or as-forged surfaces are generally satisfactory, but if the surface is unusually nonuniform, as with burned-in sand or a very rough weld deposit, interpretation may be difficult because of mechanical entrapment of the magnetic particles. In case of doubt, any questionable area should be recleaned and reexamined (see 9.1). An extensive presentation of applicable cleaning methods is described in Annex A1 of Test Method E 165.

9.2.1 *Plugging and Masking Small Holes and Openings*—Unless prohibited by the purchaser, small openings and oil holes leading to obscure passages or cavities can be plugged or masked with a suitable nonabrasive material which is readily removed. In the case of engine parts, the material must be soluble in oil. Effective masking must be used to protect components that may be damaged by contact with the particles or particle suspension.

10. Sequence of Operations

10.1 *Sequencing Particle Application and Establishing Magnetic Flux Field*—The sequence of operation in magnetic particle examination applies to the relationship between the timing and application of particles and establishing the magnetizing flux field. Two basic techniques apply, that is, continuous (see 10.1.1 and 10.1.2) and residual (see 10.1.3), both of which are commonly employed in industry.

10.1.1 *Continuous Magnetization*—Continuous magnetization is employed for most applications utilizing either dry or wet particles and should be used unless specifically prohibited in the contract, purchase order, or specification. The sequence of operation for the dry and the wet continuous magnetization techniques are significantly different and are discussed separately in 10.1.1.1 and 10.1.1.2.

10.1.1.1 *Dry Continuous Magnetization Technique*—Unlike a wet suspension, dry particles lose most of their mobility when they contact the surface of a part. Therefore, it is imperative that the part/area of interest be under the influence of the applied magnetic field while the particles are still airborne and free to be attracted to leakage fields. This dictates that the flow of magnetizing current be initiated prior to the application of dry magnetic particles and terminated after the application of powder has been completed and any excess has been blown off. Magnetizing currents of the half-wave rectified alternating and unrectified AC provide additional particle mobility on the surface of the part. Examination with dry particles is usually carried out in conjunction with prod-type localized magnetizations, and buildup of indications is observed as the particles are being applied.

10.1.1.2 *Wet Continuous Magnetization Technique*—The wet continuous magnetization technique generally applies to those parts processed on a horizontal wet type unit. In practice, it involves bathing the part with the examination medium to provide an abundant source of suspended particles on the surface of the part and terminating the bath application immediately prior to cutting off of the magnetizing current. The duration of the magnetizing current is typically on the order of ½ s with two or more shots given to the part.

10.1.1.3 *Polymer or Slurry Continuous Magnetization Technique*—Prolonged or repeated periods of magnetization are often

necessary for polymer- or slurry-base suspensions because of slower inherent magnetic particle mobility in the high-viscosity suspension vehicles.

10.1.2 *True Continuous Magnetization Technique*—In this technique, the magnetizing current is sustained throughout both the processing and examination of the part.

10.1.3 *Residual Magnetization Techniques* :

10.1.3.1 *Residual Magnetization*—In this technique, the examination medium is applied after the magnetizing force has been discontinued. It can be used only if the material being tested has relatively high retentivity so the residual leakage field will be of sufficient strength to attract and hold the particles and produce indications. This technique may be advantageous for integration with production or handling requirements or for intentionally limiting the sensitivity of the examination. It has found wide use examining pipe and tubular goods. Unless demonstrations with typical parts indicate that the residual field has sufficient strength to produce relevant indications of discontinuities (see 20.8) when the field is in proper orientation, the continuous method should be used.

10.1.3.2 *Current Quick Break*—Equipment, full-wave rectified AC, for residual magnetization must be designed to provide a consistent quick break of the magnetizing current.

11. Types of Magnetizing Currents

11.1 *Basic Current Types*—The four basic types of current used in magnetic particle examination to establish part magnetization are alternating current, single phase half-wave rectified alternating current, full-wave rectified alternating current, and for a special application, DC.

11.1.1 *Alternating Current (AC)*—Part magnetization with alternating current is preferred for those applications where examination requirements call for the detection of discontinuities, such as fatigue cracks, that are open to the surface. Associated with AC is a “skin effect” that confines the magnetic field at or near to the surface of a part. In contrast, both half-wave rectified alternating current and full-wave rectified alternating current produce a magnetic field having maximum penetrating capabilities which should be used when near-surface discontinuities are of concern. Alternating current is also extensively used for the demagnetization of parts after examination. The through-coil technique is normally used for this purpose due to its simple, fast nature. See Fig. 3.

11.1.2 *Half-Wave Rectified Alternating Current*—Half-wave rectified alternating current is frequently used in conjunction with dry particles and localized magnetization (for example, prods or yokes) to achieve some depth of penetration for detection of typical discontinuities found in weldments and ferrous castings. As with AC for magnetization, single-phase current is utilized and average value measured as “magnetizing current.”

11.1.3 *Full-Wave Rectified Alternating Current*—Full-wave rectified alternating current may utilize single- or three-phase current. Three-phase current has the advantage of lower line amperage whereas single-phase equipment is less expensive. Full-wave rectified AC is commonly used when the residual method is to be employed. With the continuous method, full-wave rectified AC is used for magnetization of coated and plated parts. Because particle movement, either dry or wet is noticeably slower, precautions must be taken to ensure that sufficient time is allowed for formation of indications.

11.1.4 *Direct Current (DC)*—A bank of batteries or a D C generator produce a direct magnetizing current. They have largely given way to half-wave rectified or full-wave rectified AC except for a few specialized applications, primarily because of battery cost and maintenance. One such example is the charging of a bank of capacitors, which on discharge is used to establish a residual magnetic field in tubing, casing, line pipe, and drill pipe.



FIG. 3 Coil Magnetization

12. Part Magnetization Techniques

12.1 *Examination Coverage*—All examinations should be conducted with sufficient area overlap to assure the required coverage at the specified sensitivity has been obtained.

12.2 *Direct and Indirect Magnetization*— A part can be magnetized either directly or indirectly. For direct magnetization the magnetizing current is passed directly through the part creating a circular magnetic field in the part. With indirect magnetization techniques a magnetic field is induced in the part which can create a circular/toroidal, longitudinal, or multidirectional magnetic field in the part. The techniques described in 20.8 for verifying that the magnetic fields have the anticipated direction and strength should be employed. This is especially important when using the multidirection technique to examine complex shapes.

12.3 *Choosing Magnetization Technique*— The choice of direct or indirect magnetization will depend on such factors as size, configuration, or ease of processing. Table 1 compares the advantages and limitations of the various methods of part magnetization.

TABLE 1 Advantages and Limitations of the Various Ways of Magnetizing a Part

Magnetizing Technique and Material Form	Advantages	Limitations
I. Direct Contact Part Magnetization (see 12.3.1)		
Head/Tailstock Contact Solid, relatively small parts (castings, forgings, machined pieces) that can be processed on a horizontal wet unit	<ol style="list-style-type: none"> 1. Fast, easy technique. 2. Circular magnetic field surrounds current path. 3. Good sensitivity to surface and near-surface discontinuities. 4. Simple as well as relatively complex parts can usually be easily processed with one or more shots. 5. Complete magnetic path is conducive to maximizing residual characteristics of material. 	<ol style="list-style-type: none"> 1. Possibility of arc burns if poor contact conditions exist. 2. Long parts should be magnetized in sections to facilitate bath application without resorting to an overly long current shot.
Large castings and forgings	<ol style="list-style-type: none"> 1. Large surface areas can be processed and examined in relatively short time. 	<ol style="list-style-type: none"> 1. High amperage requirements (16 000 to 20 000 A) dictate special DC power supply.
Cylindrical parts such as tubing, pipe, hollow shafts, etc.	<ol style="list-style-type: none"> 1. Entire length can be circularly magnetized by contacting, end to end. 	<ol style="list-style-type: none"> 1. Effective field limited to outside surface and cannot be used for inside diameter examination. 2. Ends must be conductive to electrical contacts and capable of carrying required current without excessive heat. Cannot be used on oil country tubular goods because of possibility of arc burns.
Long solid parts such as billets, bars, shafts, etc.	<ol style="list-style-type: none"> 1. Entire length can be circularly magnetized by contacting, end to end. 2. Current requirements are independent of length. 	<ol style="list-style-type: none"> 1. Voltage requirements increase as length increases due to greater impedance of cable and part. 2. Ends must be conductive to electrical contact and capable of carrying required current without excessive heat.
Prods: Welds	<ol style="list-style-type: none"> 3. No end loss. 1. Circular field can be selectively directed to weld area by prod placement. 2. In conjunction with half-wave rectified alternating current and dry powder, provides excellent sensitivity to subsurface discontinuities as well as surface type. 3. Flexible, in that prods, cables, and power packs can be brought to examination site. 	<ol style="list-style-type: none"> 1. Only small area can be examined at one time. 2. Arc burns due to poor contact. 3. Surface must be dry when dry powder is being used. 4. Prod spacing must be in accordance with the magnetizing current level.
Large castings or forgings	<ol style="list-style-type: none"> 1. Entire surface area can be examined in small increments using nominal current values. 2. Circular field can be concentrated in specific areas that historically are prone to discontinuities. 3. Equipment can be brought to the location of parts that are difficult to move. 4. In conjunction with half-wave rectified alternating current and dry powder, provides excellent sensitivity to near surface subsurface type discontinuities that are difficult to locate by other methods. 	<ol style="list-style-type: none"> 1. Coverage of large surface area require a multiplicity of shots that can be very time-consuming. 2. Possibility of arc burns due to poor contact. Surface should be dry when dry powder is being used.
II. Indirect Part Magnetization (see 12.3.2)		
Central Conductor Miscellaneous parts having holes through which a conductor can be placed such as: Bearing race Hollow cylinder Gear Large nut	<ol style="list-style-type: none"> 1. No electrical contact to part and possibility of arc burns eliminated. 2. Circumferentially directed magnetic field is generated in all surfaces, surrounding the conductor (inside diameter, faces, etc.). 	<ol style="list-style-type: none"> 1. Size of conductor must be ample to carry required current. 2. Ideally, conductor should be centrally located within hole.

TABLE 1 *Continued*

Magnetizing Technique and Material Form	Advantages	Limitations
	<ol style="list-style-type: none"> Ideal for those cases where the residual method is applicable. Light weight parts can be supported by the central conductor. Multiple turns may be used to reduce current required. 	<ol style="list-style-type: none"> Larger diameters require repeated magnetization with conductor against inside diameter and rotation of part between processes. Where continuous magnetization technique is being employed, examination is required after each magnetization.
Large clevis Pipe coupling, casing/tubing Tubular type parts such as: Pipe/Casting Tubing Hollow shaft	<ol style="list-style-type: none"> No electrical contact of part required. Inside diameter as well as outside diameter examination. Entire length of part circularly magnetized. 	<ol style="list-style-type: none"> Outside surface sensitivity may be somewhat less than that obtained on the inside surface for large diameter and extremely heavy wall.
Large valve bodies and similar parts	<ol style="list-style-type: none"> Provides good sensitivity for detection of discontinuities located on internal surfaces. 	<ol style="list-style-type: none"> Outside surface sensitivity may be somewhat less than that obtained on the inside diameter for heavy wall.
Coil/Cable Wrap	<ol style="list-style-type: none"> All generally longitudinal surfaces are longitudinally magnetized to effectively locate transverse discontinuities. 	<ol style="list-style-type: none"> Length may dictate multiple shot as coil is repositioned.
Miscellaneous medium-sized parts where the length predominates such as a crankshaft	<ol style="list-style-type: none"> Longitudinal field easily attained by means of cable wrapping. 	<ol style="list-style-type: none"> Multiple magnetization may be required due to configuration of part.
Large castings, forgings, or shafting	<ol style="list-style-type: none"> Easy and fast, especially where residual magnetization is applicable. No electrical contact. 	<ol style="list-style-type: none"> L/D (length/diameter) ratio important consideration in determining adequacy of ampere-turns. Effective L/D ratio can be altered by utilizing pieces of similar cross-sectional area. Use smaller coil for more intense field.
Miscellaneous small parts	<ol style="list-style-type: none"> Relatively complex parts can usually be processed with same ease as those with simple cross section. 	<ol style="list-style-type: none"> Sensitivity diminishes at ends of part due to general leakage field pattern. Quick break desirable to minimize end effect on short parts with low L/D ratio.
Induced Current Fixtures	<ol style="list-style-type: none"> No electrical contact. 	<ol style="list-style-type: none"> Laminated core required through ring.
Examination of ring-shaped part for circumferential-type discontinuities.	<ol style="list-style-type: none"> All surface of part subjected to toroidal-type magnetic field. Single process for 100 % coverage. Can be automated. 	<ol style="list-style-type: none"> Type of magnetizing current must be compatible with method. Other conductors encircling field must be avoided. Large diameters require special consideration.
Ball examination	<ol style="list-style-type: none"> No electrical contact. 100 % coverage for discontinuities in any direction with three-step process and proper orientation between steps. Can be automated. 	<ol style="list-style-type: none"> For small-diameter balls, limited to residual magnetization.
Disks and gears	<ol style="list-style-type: none"> No electrical contact. Good sensitivity at or near periphery or rim. Sensitivity in various areas can be varied by core or pole-piece selection. 	<ol style="list-style-type: none"> 100 % coverage may require two-step process with core or pole-piece variation, or both. Type of magnetizing current must be compatible with part geometry.
Yokes:		
Examination of large surface areas for surface-type discontinuities.	<ol style="list-style-type: none"> No electrical contact. Highly portable. Can locate discontinuities in any direction with proper orientation. 	<ol style="list-style-type: none"> Time consuming. Must be systematically repositioned in view of random discontinuity orientation.
Miscellaneous parts requiring examination of localized areas.	<ol style="list-style-type: none"> No electrical contact. Good sensitivity to direct surface discontinuities. Highly portable. Wet or dry technique. Alternating-current type can also serve as demagnetizer in some instances. 	<ol style="list-style-type: none"> Must be properly positioned relative to orientation of discontinuities. Relatively good contact must be established between part and poles. Complex part geometry may cause difficulty. Poor sensitivity to subsurface-type discontinuities except in isolated areas.

12.3.1 Direct Contact Magnetization—For direct magnetization, physical contact must be made between the ferromagnetic part and the current carrying electrodes connected to the power source. Both localized area magnetization and overall part magnetization are direct contact means of part magnetization achieved through the use of prods, head and tailstock, clamps, and magnetic leeches.

12.3.2 *Localized Area Magnetization :*

12.3.2.1 *Prod Technique*—The prod electrodes are first pressed firmly against the test part (Fig. 2(a)). The magnetizing current is then passed through the prods and into the area of the part in contact with the prods. This establishes a circular magnetic field in the part around and between each prod electrode, sufficient to carry out a local magnetic particle examination (Fig. 2(c) and Fig. 2(d)). **Caution:** Extreme care should be taken to maintain clean prod tips, to minimize heating at the point of contact and to prevent arc burns and local overheating on the surface being examined since these may cause adverse effects on material properties. Arc burns cause metallurgical damage; if the tips are solid copper, copper penetration into the part may occur. Prods should not be used on machined surfaces or on aerospace component parts.

(1) Unrectified AC limits the prod technique to the detection of surface discontinuities. Half-wave rectified AC is most desirable since it will detect both surface and near-surface discontinuities. The prod technique generally utilizes dry magnetic particle materials due to better particle mobility. Wet magnetic particles are not generally used with the prod technique because of potential electrical and flammability hazards.

(2) Proper prod examination requires a second placement with the prods rotated approximately 90° from the first placement to assure that all existing discontinuities are revealed. Depending on the surface coverage requirements, overlap between successive prod placements may be necessary. On large surfaces, it is good practice to layout a grid for prod/yoke placement.

12.3.2.2 *Manual Clamp/Magnetic Leech Technique*—Local areas of complex components may be magnetized by electrical contacts manually clamped or attached with magnetic leeches to the part (Fig. 4). As with prods, sufficient overlap may be necessary if testing of the contact location is required.

12.3.2.3 *Overall Magnetization:*

(1) *Head and Tailstock Contact* —Parts may be clamped between two electrodes (such as a head and tailstock of horizontal wet magnetic particle equipment) and the magnetizing current applied directly through the part (Fig. 5). The size and shape of the part will determine whether both field directions can be obtained with such equipment.

(2) *Clamps*—The magnetizing current may be applied to the test part by clamping the current carrying electrodes to the part, producing a circular magnetic field (Fig. 6).

(3) *Multidirectional Magnetization Technique*—With suitable circuitry, it is possible to produce a multidirectional (oscillating) field in a part by selectively switching the magnetic field within the part between electrode contacts/clamps positioned approximately 90° apart. This permits building up indications in all possible directions and may be considered the equivalent of magnetizing in two or more directions (Fig. 7). On some complex shapes as many as 16 to 20 steps may be required with conventional equipment. With multidirectional magnetization, it is usually possible to reduce the magnetizing steps required by more than half. It is essential that the wet continuous method, be used and that the magnetic field direction and relative intensity be determined by one or more of the techniques described in 20.8.

12.3.3 *Indirect Magnetization*—Indirect part magnetization involves the use of a preformed coil, cable wrap, yoke, or a central conductor to induce a magnetic field. Coil, cable wrap, and yoke magnetization are referred to as longitudinal magnetization in the part (see 13.3).



FIG. 4 Direct-Contact Magnetization Through Magnetic Leech Clamp of Part



FIG. 5 Direct Contact Magnetization Through Head/Tailstock



FIG. 6 Direct Contact Overall Magnetization

12.3.3.1 *Coil and Cable Magnetization*—When coil (Fig. 3) or cable wrap (Fig. 8) techniques are used, the magnetic field strength is proportional to ampere turns and depends on simple geometry (see 14.3.2).

12.3.3.2 *Central Conductor, Induced Current Magnetization*—Indirect circular magnetization of hollow pieces/parts can be performed by passing the magnetizing current through a central conductor (Fig. 9(a) and Fig. 9(b)) or cable used as a central conductor or through an induced current fixture (Fig. 9(c)).

12.3.3.3 *Yoke Magnetization*—A magnetic field can be induced into a part by means of an electromagnet (see Fig. 1), where the part or a portion thereof becomes the magnetic path between the poles (acts as a keeper) and discontinuities preferentially transverse to the alignment of the pole pieces are indicated. Most yokes are energized by AC, half-wave rectified AC, or full-wave rectified AC. A permanent magnet can also introduce a magnetic field in the part but its use is restricted (see 6.3.1).

13. Direction of Magnetic Fields

13.1 *Discontinuity Orientation vs. Magnetic Field Direction*—Since indications are not normally obtained when discontinuities are parallel to the magnetic field, and since indications may occur in various or unknown directions in a part, each part must be magnetized in at least two directions approximately at right angles to each other as noted in 5.3.2. On some parts circular magnetization may be used in two or more directions, while on others both circular and longitudinal magnetization are used. A multidirectional field can also be employed to achieve part magnetization in more than one direction.

13.2 *Circular Magnetization*—Circular magnetization (Fig. 10) is the term used when electric current is passed through a part, or by use of a central conductor (see 12.3.3.2) through a central opening in the part, inducing a magnetic field at right angles to the current flow.

13.3 *Toroidal Magnetization*—When magnetizing a part with a toroidal shape, such as a solid wheel or the disk with a center opening, an induced field that is radial to the disk is most useful for the detection of discontinuities in a circumferential direction.

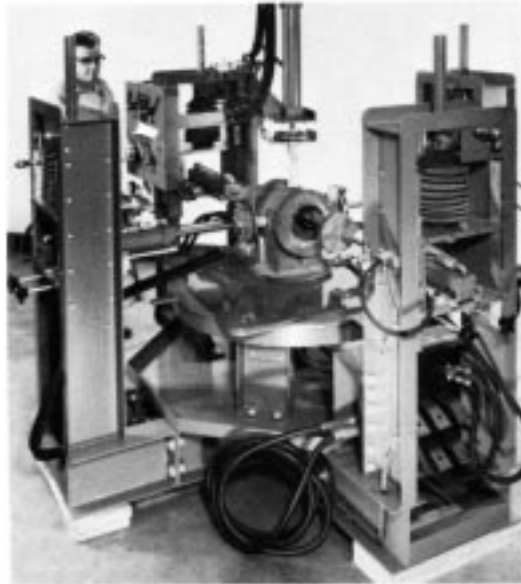

FIG. 7 Multidirectional–Overall Magnetization



FIG. 8 Cable Magnetization

In such applications this field may be more effective than multiple shots across the periphery.

13.4 *Longitudinal Magnetization*—Longitudinal magnetization (Fig. 11) is the term used when a magnetic field is generated by an electric current passing through a multiturn, Fig. 12, or laminated coil, Fig. 13, which encloses the part or section of the part to be examined.

13.5 *Multidirectional Magnetization*—~~The magnetic fields~~ Multidirectional magnetization may be induced used to fulfill the requirement for magnetization in two directions if it is demonstrated that it is effective in all areas. Test parts in accordance with 20.8.2 or shims manufactured to the part requirements of AS 5371, or as otherwise approved by passing current through the part from different directions (see 12.3.2.3 Level III and the Cognizant Engineering Organization, may be used to verify field direction, strength, and balance in multidirectional magnetization. Balance of the field intensity is critical. The field intensity shall be balanced in all directions. The particle application must be timed so that the magnetization levels reach full value in all directions, while the particles are mobile on the surface under examination. (Refer to Fig. 14). ~~Artificial flaws, circular shims, or,~~

13.5.1 When actual parts with known defects are used, the number and orientation(s) of the defects (for example, axial, longitudinal, circumferential, etc.) should be used to establish noted. The magnetic field intensity can be considered as being properly balanced when all noted defects can be readily identified with particle indications.

13.5.2 The wet continuous method must be used when performing multidirectional magnetization.

14. Magnetic Field Strength

14.1 *Magnetizing Field Strengths*—To produce interpretable indications, the magnetic field in the part must have sufficient



(a) Use of Central Conductor on Multipart Magnetization

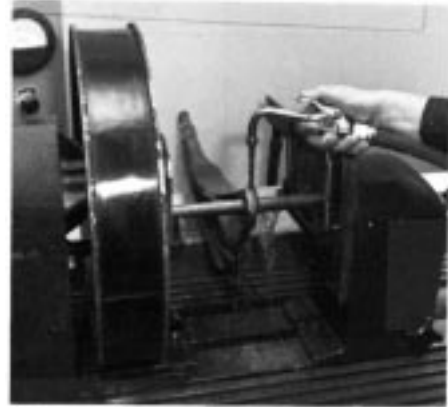

(b) Use of Central Conductor for Localized Magnetization



(c) Use of a Special Induced Current Fixture

FIG. 9 Central Conductor Induced Magnetization

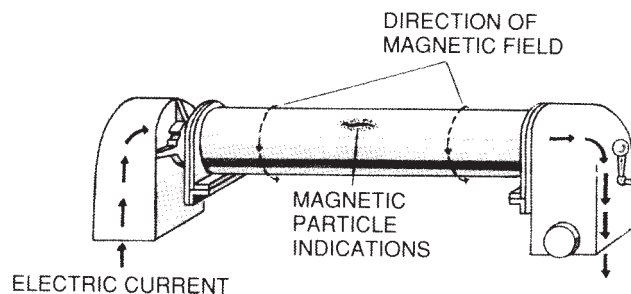

FIG. 10 Circular Magnetization

strength and proper orientation. For the indications to be consistent, this field strength must be controlled within reasonable limits, usually $\pm 25\%$. Factors that affect the strength of the field are the size, shape, section thickness, material of the part/piece, and the technique of magnetization. Since these factors vary widely, it is difficult to establish rigid rules for magnetic field strengths for every conceivable configuration.

14.2 *Establishing Field Strengths*—Sufficient magnetic field strength can be established by:

14.2.1 *Known Discontinuities*—Experiments with similar/identical parts having known discontinuities.

14.2.2 *Artificial Discontinuities*—The “pie” field indicator (Fig. 15) and slotted notched shims (Fig. 16) (Appendix X1) are artificial discontinuities. Other types of artificial flaws are available and may be selected as appropriate. See 20.8.

14.2.3 *Hall-effect Probe-Tangential Field Strengths* —Tangentially applied field strengths, as measured with a Hall-effect probe/sensor, in the range from 30 to 60 G (2.4 to 4.8 kA M^{-1}) should be adequate. See 20.8. Under some circumstances some fields in the range from 10 to 150 G may be required.

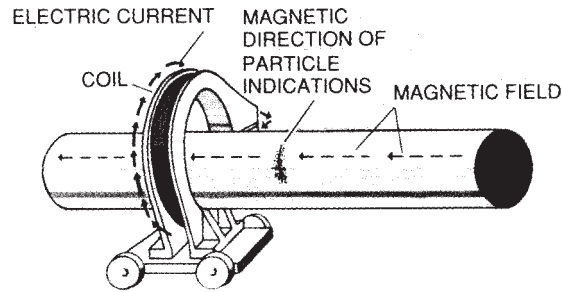

FIG. 11 Longitudinal Magnetization

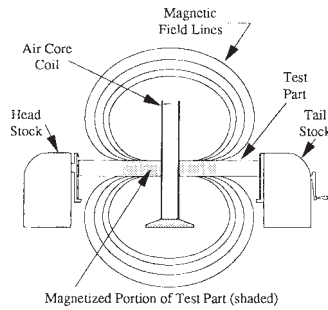

FIG. 12 Magnetic Field Produced by an Air Core Coil

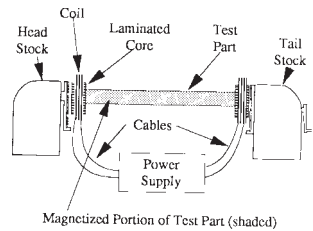

FIG. 13 Magnetic Field Produced by a Laminated Core Coil



FIG. 14 Multidirectional Magnetization

14.2.4 *Using Empirical Formulas*—Section 14.3 has four empirical formulas for establishing magnetic field strengths; they are rules of thumb. As such, they must be used with judgment. Their use may lead to:

14.2.4.1 Over magnetization, which causes excessive particle background that makes interpretation more difficult if not impossible.

14.2.4.2 Poor coverage.

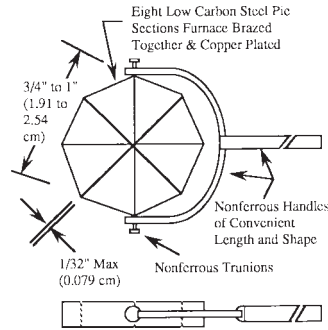

FIG. 15 Magnetic Field Indicator

14.2.4.3 Poor choice of test geometries.

14.2.4.4 A combination of the above.

14.3 *Guidelines for Establishing Magnetic Fields*—The following guidelines can be effectively applied for establishing proper levels of circular and longitudinal magnetization.

14.3.1 *Circular Magnetization—Magnetic Field Strength:*

14.3.1.1 *Direct Circular Magnetization*—When magnetizing by passing current directly through the part the nominal current should be 300–800 A/in. of part diameter (12 to 32 A/mm). The diameter of the part shall be taken as the greatest distance between any two points on the outside circumference of the part. Currents will normally be 500 A/in. (20 A/mm) or lower, with the higher currents up to 800 A/in. (32 A/mm) being used to examine for inclusions or to examine low-permeability alloys. Amperages of less than 300 A/in. may be used when part configuration dictates and approval is obtained from the Level III and the Cognizant Engineering Organization.

14.3.1.2 *Central Conductor Induced Magnetization*—Central conductors are widely used in magnetic particle examination to provide:

(1) A circular field on both the inside surface and outside surface of tubular pieces that cannot be duplicated by the direct current technique.

(2) A non-contact means of part magnetization virtually eliminating the possibility of arc burning the material, as can be the case with current flow through contacts, such as prods or clamps.

(3) Substantial processing advantages over direct contact techniques on ring-shaped parts.

(4) In general it is desirable to centrally locate a central conductor to permit the entire circumference of the part to be processed at one time. The resulting field is concentric relative to the axis of the piece and is maximum at the inside surface. The strength of the magnetic field should be verified by the means discussed in 20.8. With a centrally located central conductor, the magnetizing current requirements would be the same as a solid piece having the same outside diameter.

(5) When using offset central conductors the conductor passing through the inside of the part is placed against an inside wall of the part. The current shall be from 12 A per mm of part diameter to 32 A per mm of part diameter (300 to 800 A/in.). The diameter of the part shall be taken as the largest distance between any two points on the outside circumference of the part. Generally currents will be 500 A/in. (20 A per mm) or lower with the higher currents (up to 800 A/in.) being used to examine for inclusions or to examine low permeability alloys such as precipitation-hardening steels. For examinations used to locate inclusions in precipitation-hardening steels even higher currents, up to 1000 A/in. (40 A per mm) may be used. The distance along the part circumference which may be effectively examined shall be taken as approximately four times the diameter of the central conductor, as illustrated in Fig. 17 16. The entire circumference shall be examined by rotating the part on the conductor, allowing for

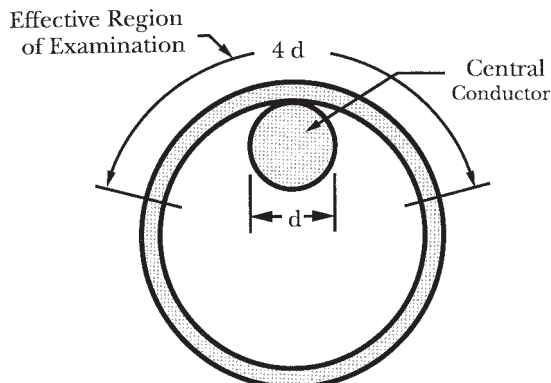

FIG. 17 16 Approximate Effective Region of Examination When Using an Offset Central Conductor (Threader Bar)

approximately a 10 % magnetic field overlap. Less overlap, different current levels, and larger effective regions (up to 360°) may be used if the presence of suitable field levels is verified.

14.3.1.23 Localized Magnetization:

~~(1) Using Prods—With prods, the strength circular magnetization is proportional to the amperage used but varies with the prod spacing and thickness of the section being examined. It is recommended that a magnetizing current from 1—When using prods on material 3/4 in. (90 to 110 A/25 (19 mm) in thickness or less, 90 to 115 A/in. of prod spacing should (3.5 to 4.5 A/mm) shall be used. For material greater than 3/4 in. (19 mm) and over in thickness. Prolonged energizing cycles may cause undesirable localized overheating. Prod thickness, 100 to 125 A/in. of prod spacing should not exceed 8 in. (200 mm); be used. Prod spacing shall not be less than 3 2 in. (75 (50 mm) is usually not practical due to banding of the particles around the prods. When the area of examination exceeds a or greater than 8 in. (200 mm). The effective width of the magnetizing field when using prods is one quarter fourth of the prod spacing, measured from spacing on each side of a centerline connecting line through the prod-centers, the magnetic field intensity should be verified at the edges of the area being examined. centers.~~

(2) *Using Yokes*—The field strength of a yoke (or a permanent magnet) can be empirically determined by measuring its lifting power (see 20.3.6). If a Hall-effect probe is used, it shall be placed on the surface midway between the poles.

14.3.2 *Air-Core Coil Longitudinal Magnetization*—Longitudinal part magnetization is produced by passing a current through a multiturn coil encircling the part or section of the part to be examined. A magnetic field is produced parallel to the axis of the coil. The unit of measurement is ampere turns (NI) (the actual amperage multiplied by the number of turns in the encircling coil or cable). The effective field extends on either side of the coil a distance approximately equal to the radius of the coil being employed. Long parts should be examined in sections not to exceed this length. There are four empirical longitudinal magnetization formulas employed for using encircling coils, the formula to be used depending on the fill factor. The formulas are included for historical continuity only. If used its use should be limited to simple shaped parts. It would be quicker and more accurate to use a Gauss (Tesla) meter, lay its probe on the part and measure the field rather than to calculate using the formulas.

14.3.2.1 *Low Fill-Factor Coils*—In this case, the cross-sectional area of the fixed encircling coil greatly exceeds the cross-sectional area of the part (less than 10 % coil inside diameter). For proper part magnetization, such parts should be placed well within the coils and close to the inside wall of the coil. With this low fill-factor, adequate field strength for eccentrically positioned parts with a length-over-diameter ratio (L/D) between 3 and 15 is calculated from the following equations:¹²

(1) *Parts With Low Fill-Factor Positioned Close to Inside Wall of Coil:*

$$NI = K/(L/D) (\pm 10 \%) \quad (1)$$

where:

- N = number of turns in the coil,
- I = coil current to be used, amperes (A),
- K = 45 000 (empirically derived constant),
- L = part, length, in., (see Note),
- D = part diameter, in.; for hollow parts, see 14.3.2.4, and
- NI = ampere turns.

For example, a part 15 in. (38.1 cm) long with 5-in. (12.7-cm) outside diameter has an L/D ratio of 15/5 or 3. Accordingly, the ampere turn requirement ($NI = 45\,000/3$) to provide adequate field strength in the part would be 15 000 ampere turns. If a five-turn coil or cable is used, the coil amperage requirements would be ($I = 15\,000/5$) = 3000 A ($\pm 10 \%$). A500 turn coil would require 30 A ($\pm 10 \%$).

(2) *Parts with a Low Fill-Factor Positioned in the Center of the Coil:*

$$NI = KR/\{(6L/D) - 5\}(\pm 10 \%) \quad (2)$$

where:

- N = number of turns in the coil,
- I = coil current to be used, A,
- K = 43 000 (empirically derived constant),
- R = coil radius, in.,
- L = part length, in. (see Note),
- D = part diameter, in., for hollow parts (see 14.3.2.4), and
- NI = ampere turns.

For example, a part 15 in. (38.1 cm) long with 5-in. (12.7-cm) outside diameter has a L/D ratio of 15/5 or 3. If a five-turn 12-in. diameter (6-in. radius) (30.8-cm diameter (15.4-cm radius)) coil or cable is used, (I) the ampere turns requirement would be as follows:

¹² These equations are included for historical continuity only. It is faster to buy a Tesla meter, lay the probe on the part and measure the field strength than calculating using the equations.

$$NI = \frac{(43\,000 \times 6)}{((6 \times 3) - 5)} \text{ or } 19\,846$$

and (2) the coil amperage requirement would be as follows:

$$\frac{19\,846}{5} \text{ or } 3\,969 \text{ A } (\pm 10 \%)$$

14.3.2.2 *Intermediate Fill-Factor Coils*—When the cross section of the coil is greater than twice and less than ten times the cross section of the part being examined:

$$NI = (NI)_{\text{hf}}(10 - Y) + (NI)_{\text{lf}}(Y - 2)/8 \quad (3)$$

where:

NI_{hf} = value of NI calculated for high fill-factor coils using Eq 3,

NI_{lf} = value of NI calculated for low fill-factor coils using Eq 1 or Eq 2, and

Y = ratio of the cross-sectional area of the coil to the cross section of the part. For example, if the coil has an inside diameter of 10 in. (25.4 cm) and part (a bar) has an outside diameter of 5 in. (12.2 cm)

$$Y = (\pi(5)^2)/(\pi(2.5)^2) = 4$$

14.3.2.3 *High Fill-Factor Coils*—In this case, when fixed coils or cable wraps are used and the cross-sectional area of the coil is less than twice the cross-sectional area (including hollow portions) of the part, the coil has a high fill-factor.

(1) For Parts Within a High Fill-Factor Positioned Coil and for Parts with an L/D ratio equal to or greater than 3:

$$NI = \frac{K}{\{(L/D) + 2\}} (\pm 10 \%)$$

where:

N = number of turns in the coil or cable wrap,

I = coil current, A,

K = 35 000 (empirically derived constant),

L = part length, in.,

D = part diameter, in., and

NI = ampere turns.

For example, the application of Eq 3 can be illustrated as follows: a part 10 in. (25.4 cm) long-with 2-in. (5.08-cm) outside diameter would have an L/D ratio of 5 and an ampere turn requirements of $NI = 35\,000/(5 + 2)$ or 5000 ($\pm 10 \%$) ampere turns. If a five-turn coil or cable wrap is employed, the amperage requirement is 5000/5 or 1000 A ($\pm 10 \%$).

NOTE 1—For L/D ratios less than 3, a pole piece (ferromagnetic material approximately the same diameter as part) should be used to effectively increase the L/D ratio or utilize an alternative magnetization method such as induced current. For L/D ratios greater than 15, a maximum L/D value of 15 should be used for all formulas cited above.

14.3.2.4 *L/D Ratio for a Hollow Piece*—When calculating the L/D ratio for a hollow piece, D shall be replaced with an effective diameter D_{eff} calculated using:

$$D_{\text{eff}} = [(A_t - A_h)/\pi]^{1/2}$$

$$D_{\text{eff}} = 2[(A_t - A_h)/\pi]^{1/2}$$

where:

A_t = total cross-sectional area of the part, and

A_h = cross-sectional area of the hollow portion(s) of the part.

For a cylindrical piece, this is equivalent to:

$$D_{\text{eff}} = [(OD)^2 - (ID)^2]^{1/2}$$

where:

OD = outside diameter of the cylinder, and

ID = inside diameter of the cylinder.

15. Application of Dry and Wet Magnetic Particles

15.1 Dry Magnetic Particles:

15.1.1 *Magnetic Fields for Dry Particles*—Dry magnetic powders are generally applied with the continuous magnetizing techniques utilizing AC or half-wave rectified AC or yoke magnetization. A current duration of at least ½ s should be used. The current duration should be short enough to prevent any damage from overheating or from other causes. It should be noted that AC and half-wave rectified AC impart better particle mobility to the powder than DC or full-wave rectified AC. Dry magnetic powders are widely used for magnetic particle examination of large parts as well as on localized areas such as welds. Dry magnetic particles are widely used for oil field applications and are frequently used in conjunction with capacitor discharge style equipment and the residual method.

15.1.2 *Dry Powder Application*—Dry powders should be applied in such a manner that a light uniform, dust-like coating settles upon the surface of the part/piece while it is being magnetized. Dry particles must not be applied to a wet surface; they will have limited mobility. Neither should they be applied where there is excessive wind. The preferred application technique suspends the particles in air in such a manner that they reach the part surface being magnetized in a uniform cloud with a minimum of force. Usually, specially designed powder blowers and hand powder applicators are employed (Fig. 1(b) and Fig. 4). Dry particles should not be applied by pouring, throwing, or spreading with the fingers.

15.1.3 *Excess Powder Removal*—Care is needed in both the application and removal of excess dry powder. While the magnetizing current is present, care must be exercised to prevent the removal of particles attracted by a leakage field that may prove to be a relevant indication of a discontinuity.

15.1.4 *Near-surface Discontinuities Powder Patterns* —In order to recognize the broad, fuzzy, weakly held powder patterns produced by near-surface discontinuities, it is essential to observe carefully the formation of indications while the powder is being applied and also while the excess is being removed. Sufficient time for indication formation and examination should be allowed between successive magnetization cycles.

15.2 *Wet Particle Application*—Wet magnetic particles, fluorescent or nonfluorescent, suspended in a vehicle at a recommended concentration may be applied either by spraying or flowing over the areas to be inspected during the application of the magnetizing field current (continuous technique) or after turning off the current (residual technique). Proper sequencing of operation (part magnetization and timing of bath application) is essential to indication formation and retention. For the continuous technique multiple current shots should be applied. The last shot should be applied after the particle flow has been diverted and while the particle bath is still on the part. A single shot may be sufficient. Care should be taken to prevent damage to a part due to overheating or other causes. Since fine or weakly held indications on highly finished or polished surfaces may be washed away or obliterated, care must be taken to prevent high-velocity flow over critical surfaces and to cut off the bath application before removing the magnetic field. Since a residual field has a lower intensity than a continuous field, less pronounced indications tend to form.

15.3 *Magnetic Slurry/Paints*—Magnetic slurry/paints are applied to the part with a brush before or during part magnetization. Indications appear as a dark line against a light silvery background. Magnetic slurry is ideal for overhead or underwater magnetic particle examination.

15.4 *Magnetic Polymers*—Magnetic polymers are applied to the test part as a liquid polymer suspension. The part is then magnetized, the polymer is allowed to cure, and the elastic coating is removed from the test surface for examination. Care must be exercised to ensure that magnetization is completed within the active migration period of the polymer which is usually about 10 min. This method is particularly applicable to areas of limited visual access such as bolt holes. Detailed application and use instructions of the manufacturer should be followed for optimum results.

16. Interpretation of Indications

16.1 *Valid Indications*—All valid indications formed by magnetic particle examination are the result of magnetic leakage fields. Indications may be relevant (16.1.1), nonrelevant (16.1.2), or false (16.1.3).

16.1.1 *Relevant Indications*—Relevant indications are produced by leakage fields which are the result of discontinuities. Relevant indications require evaluation with regard to the acceptance standards agreed upon between the manufacturer/test agency and the purchaser (see Annex A1).

16.1.2 *Nonrelevant Indications*—Nonrelevant indications can occur singly or in patterns as a result of leakage fields created by conditions that require no evaluation such as changes in section (like keyways and drilled holes), inherent material properties (like the edge of a bimetallic weld), magnetic writing, etc.

16.1.3 *False Indications*—False indications are not the result of magnetic forces. Examples are particles held mechanically or by gravity in shallow depressions or particles held by rust or scale on the surface.

17. Recording of Indications

17.1 *Means of Recording*—When required by a written procedure, permanent records of the location, type, direction, length(s), and spacing(s) of indications may be made by one or more of the following means.

17.1.1 *Sketches*—Sketching the indication(s) and their locations.

17.1.2 *Transfer (Dry Powder Only)*—Covering the indication(s) with transparent adhesive-backed tape, removing the tape with the magnetic particle indication(s) adhering to it, and placing it on paper or other appropriate background material indicating locations.

17.1.3 *Strippable Film (Dry Powder Only)*—Covering the indication(s) with a spray-on strippable film that fixes the indication(s) in place. When the film is stripped from the part, the magnetic particle indication(s) adhere to it.

17.1.4 *Photographing*—Photographing the indications themselves, the tape, or the strippable film reproductions of the indications.

17.1.5 *Written Records*—Recording the location, length, orientation, and number of indications.

17.2 *Accompanying Information*—A record of the procedure parameters listed below as applicable should accompany the inspection results:

17.2.1 *Method Used*—Magnetic particle method (dry, wet, fluorescent, etc.).

17.2.2 *Magnetizing Technique*—Magnetizing technique (continuous, true-continuous, residual).

17.2.3 *Current Type*—Magnetizing current (AC, half-wave rectified or full-wave rectified AC, etc.).

17.2.4 *Field Direction*—Direction of magnetic field (prod placement, cable wrap sequence, etc.).

17.2.5 *Field Strength*—Magnetic current strength (ampere turns, amperes per millimetre (inch) of prod spacing, lifting force, etc.).

18. Demagnetization

18.1 *Applicability*—All ferromagnetic material will retain some residual magnetism, the strength of which is dependent on the retentivity of the part. Residual magnetism does not affect the mechanical properties of the part. However, a residual field may cause chips, filing, scale, etc. to adhere to the surface affecting subsequent machining operations, painting, or plating. Additionally, if the part will be used in locations near sensitive instruments, high residual fields could affect the operation of these instruments. Furthermore, a strong residual magnetic field in a part to be arc welded could interfere with welding. Residual fields may also interfere with later magnetic particle examination. Demagnetization is required only if specified in the drawings, specification, or purchase order. When required, an acceptable level of residual magnetization and the measuring method shall also be specified. See 18.3.

18.2 *Demagnetization Methods*—The ease of demagnetization is dependent on the coercive force of the metal. High retentivity is not necessarily related to high coercive force in that the strength of the residual field is not always an indicator of ease of demagnetizing. In general, demagnetization is accomplished by subjecting the part to a field equal to or greater than that used to magnetize the part and in nearly the same direction, then continuously reversing the field direction while gradually decreasing it to zero.

18.2.1 *Withdrawal from Alternating Current Coil*—The fastest and most simple technique is to pass the part through a high intensity alternating current coil and then slowly withdraw the part from the field of the coil. A coil of 5000 to 10 000 ampere turns is recommended. Line frequency is usually from 50 to 60 Hz alternating current. The piece should enter the coil from a 12-in. (300-mm) distance and move through it steadily and slowly until the piece is at least 36 in. (900 mm) beyond the coil. Care should be exercised to ensure that the part is entirely removed from the influence of the coil before the demagnetizing force is discontinued, otherwise the demagnetizer may have the reverse effect of magnetizing the part. This should be repeated as necessary to reduce the residual field to an acceptable level. See 18.3. Small parts of complex figuration can be rotated and tumbled while passing through the field of the coil.

18.2.2 *Decreasing Alternating Current*—An alternative technique for part demagnetization is subjecting the part to the field while gradually reducing its strength to a desired level.

18.2.3 *Demagnetizing With Yokes*—Alternating current yokes may be used for local demagnetization by placing the poles on the surface, moving them around the area, and slowly withdrawing the yoke while it is still energized.

18.2.4 *Reversing Direct Current*—The part to be demagnetized is subjected to consecutive steps of reversed and reduced direct current magnetization to a desired level. (This is the most effective process of demagnetizing large parts in which the alternating current field has insufficient penetration to remove the internal residual magnetization.) This technique requires special equipment for reversing the current while simultaneously reducing it in small increments.

18.3 *Extent of Demagnetization*—The effectiveness of the demagnetizing operation can be indicated by the use of appropriate magnetic field indicators or field strength meters. **Caution:** A part may retain a strong residual field after having been circularly magnetized and exhibit little or no external evidence of this field. Therefore, the circular magnetization should be conducted before longitudinal magnetization if complete demagnetization is required.

18.3.1 After demagnetization residual fields should not exceed 3 G (240 Am^{-1}) anywhere in the piece, absolute value, unless otherwise agreed upon or as specified on the engineering drawing or in the contract, purchase order, or specification.

19. Post Examination Cleaning

19.1 *Particle Removal*—Post-test cleaning is necessary where magnetic particle material(s) could interfere with subsequent processing or with service requirements. The purchaser should specify when post-test cleaning is needed and the extent required.

19.2 *Means of Particle Removal*—Typical post-test cleaning techniques employed are: (a) the use of compressed air to blow off unwanted dry magnetic particles; (b) drying of wet particles and subsequent removal by brushing or with compressed air; (c) removal of wet particles by flushing with solvent; and (d) other suitable post-examination cleaning techniques may be used if they will not interfere with subsequent requirements.

20. Evaluation of System Performance/Sensitivity

20.1 *Contributing Factors*—The overall performance/sensitivity of a magnetic particle examination system is dependent upon the following:

- 20.1.1 Operator capability, if a manual operation is involved.
- 20.1.2 Control of process steps.
- 20.1.3 The particles or suspension, or both.
- 20.1.4 The equipment.
- 20.1.5 Visible light level.
- 20.1.6 Black light monitoring where applicable.
- 20.1.7 Magnetic field strength.
- 20.1.8 Field direction or orientation.
- 20.1.9 Residual field strength.
- 20.1.10 These factors should all be controlled individually.

20.2 *Maintenance and Calibration of Equipment*—The magnetic particle equipment employed should be maintained in proper working order at all times. The frequency of verification calibration, usually every six months, see Table 2, or whenever a malfunction is suspected, should be specified in the written procedures of the testing facility. Records of the checks and results provide useful information for quality control purposes and should be maintained. In addition, any or all of the tests described should be performed whenever a malfunction of the system is suspected. Calibration tests should be conducted in accordance with the specifications or documents that are applicable.

20.3 *Equipment Checks*—The following tests are recommended for ensuring the accuracy of magnetic particle magnetizing equipment.

20.3.1 *Ammeter Accuracy*—The equipment meter readings should be compared to those of a control test meter incorporating a shunt or current transformer connected to monitor the output current. The accuracy of the entire control test meter arrangement should be verified at six-month intervals or as agreed upon between the purchaser and supplier by a means traceable to the National Institute of Standards and Technology (NIST). Comparative readings shall be taken at a minimum of three output levels encompassing the usable range. The equipment meter reading shall not deviate by more than $\pm 10\%$ of full scale relative to the actual current values as shown by the test meter. **Caution:** When measuring half-wave rectified AC, the direct current reading of a conventional DC test meter reading must be doubled.

20.3.2 *Timer Control Check*—On equipment utilizing a timer to control the duration of the current flow, the timer should be checked for accuracy as specified in Table 2 or whenever a malfunction is suspected.

20.3.3 *Magnetic Field Quick Break Check*—On equipment that has a quick break feature, the functioning of this circuit should be checked and verified. This test may be performed using a suitable oscilloscope or a simple test device usually available from the manufacturer. On electronic power packs or machines, failure to achieve indication of a “quick break” would indicate that a malfunction exists in the energizing circuit.

20.3.4 *Equipment Current Output Check*—To ensure the continued accuracy of the equipment, ammeter readings at each transformer tap should be made with a calibrated ammeter-shunt combination. This accessory is placed in series with the contacts. The equipment shunt should not be used to check the machine of which it is a part. For infinite current control units (non-tap switch), settings at 500-A intervals should be used. Variations exceeding $\pm 10\%$ from the equipment ammeter readings indicate the equipment needs service or repair.

20.3.5 *Internal Short Circuit Check*—Magnetic particle equipment should be checked periodically for internal short circuiting. With the equipment set for maximum amperage output, any deflection of the ammeter when the current is activated with no

TABLE 2 Recommended Verification Intervals

Item	Maximum Time Between Verifications ^A	Reference Paragraphs
Lighting:		
Visible light intensity	1 week	7.1.1
Black light intensity	1 week	7.1.2
Background visible light intensity	1 week ^A	7.1.1
System performance using test piece or ring specimen of Fig. 18	1 day	20.8.3
<u>System performance using test piece or ring specimen of Fig. 17</u>	<u>1 day</u>	<u>20.8.3</u>
Wet particle concentration	8 h, or every shift change	20.6
Wet particle contamination	1 week	20.6.4
Water break test	1 day	20.7.3
<u>Water break test</u>	<u>1 day</u>	<u>20.7.5</u>
Equipment calibration/check:		
Ammeter accuracy	6 months	20.3.1
Timer control	6 months	20.3.2
Quick break	6 months	20.3.3
Dead weight check	6 months	20.3.6
Light meter checks	6 months	20.4

^A Note—The maximum time between verifications may be extended when substantiated by actual technical stability/reliability data.

conductor between the contacts is an indication of an internal short circuit.

20.3.6 *Electromagnetic Yoke Lifting Force Test*—The magnetizing force of a yoke (or a permanent magnet) should be tested by determining its lifting power on a steel plate. See Table 3. The lifting force relates to the electromagnetic strength of the yoke.

20.3.7 *Powder Blower*—The performance of powder blowers used to apply the dry magnetic particles should be checked at routine intervals or whenever a malfunction is suspected. The check should be made on a representative test part. The blower should coat the area under test with a light, uniform dust-like coating of dry magnetic particles and have sufficient force to remove the excess particles without disturbing those particles that are evidence of indications. Necessary adjustments to the blower’s flow rate or air velocity should be made in accordance with the manufacturer’s recommendations.

20.4 *Examination Area Light Level Control:*

20.4.1 *Visible Light Intensity*—Light intensity in the examination area should be checked at specified intervals with the designated light meter at the surface of the parts being examined. See Table 2.

20.4.2 *Black (ultraviolet) Light Intensity*—Black light intensity and wavelength should be checked at the specified intervals but not to exceed one-week intervals and whenever a bulb is changed. Reflectors and filters should be cleaned daily and checked for integrity. See Table 2. Cracked or broken UV filters shall be replaced immediately. Defective bulbs which radiate UV energy must also be replaced before further use.

20.5 *Dry Particle Quality Control Tests*— In order to assure uniform and consistent performance from the dry magnetic powder selected for use, it is advisable that all incoming powders be certified or tested for conformance with quality control standards established between the user and supplier.

20.5.1 *Contamination:*

20.5.1.1 *Degradation Factors*—Dry magnetic particles are generally very rugged and perform with a high degree of consistency over a wide process envelope. Their performance, however, is susceptible to degradation from such contaminants as moisture, grease, oil, rust and mill scale particles, nonmagnetic particles such as foundry sand, and excessive heat. These contaminants will usually manifest themselves in the form of particle color change and particle agglomeration, the degree of which will determine further use of the powder. Over-heated dry particles can lose their color, thereby reducing the color contrast with the part and thus hinder part examination. Particle agglomeration can reduce particle mobility during processing, and large particle agglomerates may not be retained at an indication.

20.5.1.2 *Ensuring Particle Quality*—To ensure against deleterious effects from possible contaminants, it is recommended that a routine performance/sensitivity test be conducted (see 20.8.3).

20.6 *Wet Particle Quality Control Tests*— The following tests for wet magnetic particle suspensions should be conducted at startup and at regular intervals to assure consistent performance. See Table 2. Since bath contamination will occur as the bath is used, monitoring the working bath at regular intervals is essential.

20.6.1 *Determining Bath Concentration*— Bath concentration and sometimes bath contamination are determined by measuring its settling volume through the use of a Test Method D 1966 pear-shaped centrifuge tube with a 1-mL stem (0.05-mL divisions) for fluorescent particle suspensions or a 1.5-mL stem (0.1-mL divisions) for nonfluorescent suspensions. Before sampling, the suspension should be run through the recirculating system for at least 30 min to ensure thorough mixing of all particles which could have settled on the sump screen and along the sides or bottom of the tank. Take a 100-mL portion of the suspension from the hose or nozzle, demagnetize and allow it to settle for approximately 60 min with petroleum distillate suspensions or 30 min with water-based suspensions before reading. The volume settling out at the bottom of the tube is indicative of the particle concentration in the bath.

20.6.2 *Sample Interpretation*—If the bath concentration is low in particle content, add a sufficient amount of particle materials to obtain the desired concentration; if the suspension is high in particle content, add sufficient vehicle to obtain the desired concentration. If the settled particles appear to be loose agglomerates rather than a solid layer, take a second sample. If still agglomerated, the particles may have become magnetized; replace the suspension.

20.6.3 *Settling Volumes*—For fluorescent particles, the recommended settling volume (see ~~8.4.6~~ 15.2) is from 0.1 to 0.4 mL in a 100-mL bath sample and from 1.2 to 2.4 mL per 100 mL of vehicle for non-fluorescent particles, unless otherwise specified approved by the Cognizant Engineering Organization (CEO). Refer to appropriate AMS document (3041, 3042, 3043, 3044, 3045, and/or 3046). For dual-colored particles, the recommended settling volume should be determined by the performance requirements and lighting environment of a given application as recommended by the manufacturer. See 8.5.5.

20.6.4 *Bath Contamination*—Both fluorescent and nonfluorescent suspensions should be checked periodically for contaminants such as dirt, scale, oil, lint, loose fluorescent pigment, water (in the case of oil suspensions), and particle agglomerates which can adversely affect the performance of the magnetic particle examination process. See Table 2.

TABLE 3 Minimum Yoke Lifting Force

Type Current	Yoke Pole Leg Spacing	
	50 to 100 mm (2 to 4 in.)	100 to 150 mm (4 to 6 in.)
AC	45 N (10 lb)	
DC	135 N (30 lb)	225 N (50 lb)

20.6.4.1 *Carrier Contamination*—For fluorescent baths, the liquid directly above the precipitate should be examined with black light. The liquid will have a little fluorescence. Its color can be compared with a freshly made-up sample using the same materials or with an unused sample from the original bath that was retained for this purpose. If the “used” sample is noticeably more fluorescent than the comparison standard, the bath should be replaced.

20.6.4.2 *Particle Contamination*—The graduated portion of the tube should be examined under black light if the bath is fluorescent and under visible light (for both fluorescent and nonfluorescent particles) for striations or bands, differences in color or appearance. Bands or striations may indicate contamination. If the total volume of the contaminates, including bands or striations exceeds 30 % of the volume of magnetic particles, or if the liquid is noticeably fluorescent (see 20.6.4.1), the bath should be replaced.

20.6.5 *Particle Durability*—The durability of both the fluorescent and nonfluorescent magnetic particles in suspension should be checked periodically to ensure that the particles have not degraded due to chemical attack from the suspending oil or conditioned water vehicles or mechanically degraded by the rotational forces of the recirculating pump in a wet horizontal magnetic particle unit. Fluorescent magnetic particle breakdown in particular can result in a decrease in sensitivity and an increase in nonmagnetic fluorescent background. Lost fluorescent pigment can produce false indications that can interfere with the examination process.

20.6.6 *Fluorescent Brightness*—It is important that the brightness of fluorescent magnetic particle powder be maintained at the established level so that indication and background brightness can be kept at a relatively constant level. Variations in contrast can noticeably affect test results. Lack of adequate contrast is generally caused by:

20.6.6.1 An increase in contamination level of the vehicle increasing background fluorescence, or

20.6.6.2 Loss of vehicle because of evaporation, increasing concentration, or

20.6.6.3 Degradation of fluorescent particles. A change in contrast ratio can be observed by using a test ring specimen with an etched surface.

20.6.7 *Performance/Sensitivity*—Failure to find a known discontinuity in a part or obtain the specified indications on the test ring (see 20.8.3) indicates a need for changing of the entire bath. If a part was used, it must have been ultrasonically cleaned so that no fluorescent background can be detected when viewed under black light with a surface intensity of at least 1000 $\mu\text{W}/\text{cm}^2$. If any background is noted that interferes with either detection or interpretation, the bath should be drained and a new suspension made.

20.6.8 *Magnetic Stripe Cards*—The encoded pattern on the magnetic stripes of magnetic stripe cards may serve as a test piece for the evaluation of particle sensitivity. Particles are attracted to magnetic gradients formed when the stripe has been encoded. See Appendix X2 for further information.

20.7 *Bath Characteristics Control* :

20.7.1 *Oil Bath Fluids*—Properties of oil-bath fluids are described in AMS 2641 or A-A-59230.

20.7.2 *Water Bath Fluids*—Properties of conditioned water-bath fluids are described in AS 4792.

20.7.3 *Viscosity*—The viscosity of the suspension should not exceed 5 mm^2/s (5.0 cSt), at any temperature at which the bath may be used, when tested in accordance with Test Method D 445.

20.7.24 *Flash Point*—The flash point of wet magnetic particle light petroleum distillate suspension should be a minimum of 200°F (93°C); use Test Method D 93.

20.7.35 *Water Break Test for Conditioned Water Vehicles* —Properly conditioned water will provide proper wetting, particle dispersion, and corrosion protection. The water break test should be performed by flooding a part, similar in surface finish to those under test, with suspension, and then noting the appearance of the surface of the part after the flooding is stopped. If the film of suspension is continuous and even all over the part, sufficient wetting agent is present. If the film of suspension breaks, exposing bare surfaces of the part, and the suspension forms many separate droplets on the surface, more wetting agent is needed or the part has not been sufficiently cleaned.

20.7.46 *pH of Conditioned Water Vehicles*— The pH of the conditioned water bath should be between ~~6.0~~ 7.0 and 10.5 as determined by a suitable pH meter or special pH paper.

20.8 *Verifying System Performance* :

System performance tests must be conducted in accordance with a written procedure so that the test is performed in the same manner each time.

20.8.1 *Production Test Parts with Discontinuities*—A practical way to evaluate the performance and sensitivity of the dry or wet magnetic particles or overall system performance, or both, is to use representative test parts with known discontinuities of the type and severity normally encountered during actual production inspection. However, the usefulness of such parts is limited because the orientation and magnitude of the discontinuities cannot be controlled. The use of flawed parts with gross discontinuities is not recommended. **Caution**—If such parts are used, they must be thoroughly cleaned and demagnetized after each use.

20.8.2 *Fabricated Test Parts with Discontinuities*—Often, production test parts with known discontinuities of the type and severity needed for evaluation are not available. As an alternative, fabricated test specimens with discontinuities of varying degree and severity can be used to provide an indication of the effectiveness of the dry or wet magnetic particle examination process.

20.8.3 *Test Plate*—~~The~~—A magnetic particle system performance test plate, such as shown in Fig. 18 17 is useful for testing the overall performance of systems wet or dry techniques using prods and yokes. Recommended minimum dimensions are ten

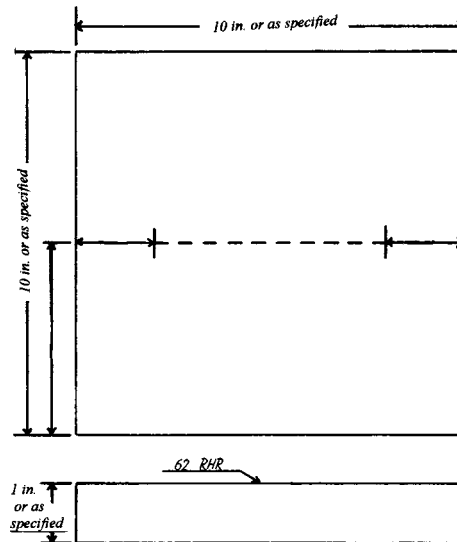

FIG. 17 Sample of a Magnetic Particle Performance Test Plate. Defects are formed and located in accordance with plate manufacturers' specifications.

inches per side and nominal thickness of one inch. Discontinuities can be formed by controlled heating/cooling, EDM notches, artificial discontinuities per 14.2.2 or other means.

NOTE 2—Notches are to be filled flush to the surface with a nonconducting material, such as epoxy, to prevent the mechanical holding of the indicating medium.

20.8.4 *Test Ring Specimen*—The A test (Ketos) ring specimen (Fig. 19) is may also be used in evaluating and comparing the overall performance and sensitivity of both dry and wet, fluorescent and non-fluorescent magnetic particle techniques using a central conductor magnetization technique. Refer to Practice E 1444, Appendix X1.

20.8.4.1 *Test Ring Material*—The tool steel (Ketos) ring should be machined from AISI O1 material in accordance with Fig. 19. Either the machined ring or the steel blank should be annealed at 1650°F (900°C), cooled 50°F (28°C) per hour to 1000°F (540°C) and then air cooled to ambient temperature to give comparable results using similar rings that have had the same treatment. Material and heat treatment are important variables. Experience indicates controlling the softness of the ring by hardness (90 to 95 HRB) alone is insufficient.

20.8.4.2 *Using the Test Ring*—If using the test ring, Fig. 19, is circularly magnetized with full-wave rectified AC passing through place a central conductor with a diameter between 1 to 1¼ in. and 1.25 in. (25 to 31 mm) diameter hole located in the ring center. The conductor should have and 31 mm) and a length greater longer than 16 in. (400 mm). The current used, unless otherwise agreed upon (40 cm) through the center of the ring. Center the ring on the length of the conductor. Magnetize the ring circularly by passing the user and current through the particle manufacturer, shall be 1400 amps. For dry conductor as described in Appendix X1 of Practice E 1444. Gently apply particles to the minimum number surface of holes shown shall be four. For wet particles the ring while the current is flowing. Examine the ring within one minumte after current application. The number of holes shown shall be three. The ring edge hole indications visible should be examined after 1 min with either black light meet or visible light, see 20.4 depending on the type exceed those as specified in Appendix X1 of partieles involved. Practice E 1444.

20.8.5 *Magnetic Field Indicators:*

20.8.5.1 *“Pie” Field Indicator*— The magnetic field indicator shown in Fig. 15 relies on the slots between the pie shaped segments to show the presence and the approximate direction of the magnetic field. A suitable field strength is indicated when a clearly defined line of magnetic particles forms across the copper face of the indicator (the slots are against the piece) when the magnetic particles are applied simultaneously with the magnetizing force. Failure to obtain an indication can result from: (1) insufficient magnetic field, or (2) the magnetic properties of the material being examined, or both.

20.8.5.2 *Slotted Shims*—Several types of slotted shims exist. Three, shown in Fig. 16, similar but not identical, have been used by the Japanese for a number of years Refer to AS 5371 and are being manufactured to illustrations in the United States. Slot depths of 15, 30, and 60 % of the shim thickness can be obtained; the slots being chemically milled. The slotted side is placed in close contact with the piece. The linear (bar) slot is useful when discontinuities are critical in a specific direction. The circular slot indicates the direction of maximum field strength and the angular tolerance of sensitivity. It can be used for developing multidirectional magnetizing procedures. The radially slotted strip has been found most useful for parts with narrow spaces and small radii. The true continuous method (10.1.2) of magnetization must be used, that is, the particles must be applied before the current flow is stopped. For dry powder applications, the excess powder must be blown off before the current stops flowing. Appendix X1.

20.8.6 *Half-effect Probe*—The Hall-effect probe or sensor measures the tangential field strength (in air adjacent to the part) of the magnetizing force (H) and is calibrated in gauss. The sensor must be used with care. It must be kept close to the part surface. The manufacturer's instructions should be followed. These instruments can be used to detect a residual field or measure fields produced during head shots and shots using a central conductor.

21. Procedures

21.1 When specified a procedure should be written for all magnetic particle examinations and should include as a minimum the following information. A sketch is usually used for illustrating part geometry, techniques, and areas for examination. This sketch may also be used for recording location of magnetic field indicators and for recording location of discontinuities.

- 21.1.1 Area to be examined (entire part or specific area),
- 21.1.2 Type of magnetic particle material (dry or wet, visible or fluorescent),
- 21.1.3 Magnetic particle equipment,
- 21.1.4 Part surface preparation requirements,
- 21.1.5 Magnetizing process (continuous, true-continuous, residual),
- 21.1.6 Magnetizing current (alternating, half-wave rectified AC, full-wave rectified AC, direct),
- 21.1.7 Means of establishing part magnetization (direct-prods, head/tailstock contact or cable wrap, indirect-coil/cable wrap, yoke, central conductor, and so forth),
- 21.1.8 Direction of magnetic field (circular or longitudinal),
- 21.1.9 System performance/sensitivity checks,
- 21.1.10 Magnetic field strength (ampere turns, field density, magnetizing force, and number and duration of application of magnetizing current),
- 21.1.11 Application of examination media,
- 21.1.12 Interpretation and evaluation of indications,
- 21.1.13 Type of records including accept/reject criteria,
- 21.1.14 Demagnetizing techniques, if required, and
- 21.1.15 Post-examination cleaning, if required,
- 21.2 *Written Reports*—Written reports shall be prepared as agreed upon between the testing agency/department and the purchaser/user.

22. Acceptance Standards

22.1 The acceptability of parts examined by this method is not specified herein. Acceptance standards are a matter of agreement between the manufacturer and the purchaser and should be stated in a referenced contract, specification, or code.

23. Safety

- 23.1 Those involved with hands-on magnetic particle examination exposure to hazards include:
 - 23.1.1 *Electric Shock and Burns*—Electric short circuits can cause shock and particularly burns from the high amperages at relatively low voltages that are used. Equipment handling water suspensions should have good electrical grounds.
 - 23.1.2 *Flying Particles*—Magnetic particles, particularly the dry ones, dirt, foundry sand, rust, and mill scale can enter the eyes and ears when they are blown off the part when applying them to a vertical or overhead surface or when cleaning an examined surface with compressed air. Dry particles are easy to inhale and the use of a dust respirator is recommended.
 - 23.1.3 *Falls*—A fall from a scaffold or ladder if working on a large structure in the field or shop.
 - 23.1.4 *Fire*—Ignition of a petroleum distillate bath.
 - 23.1.5 *Environment*—Doing magnetic particle examination where flammable vapors are present as in a petrochemical plant or oil refinery. Underwater work has its own set of hazards.
 - 23.1.6 *Wet Floors*—Slipping on a floor wetted with a particle suspension.
 - 23.1.7 *Shifting or Dropping of Large Components*—Large components, especially those on temporary supports can shift during examination or fall while being lifted. In addition, operators should be alert to the possibility of injury to body members being caught beneath a sling/chain or between head/tail stock and the piece.
 - 23.1.8 *Ultraviolet Light Exposure*—Ultraviolet light in excess of 1000 $\mu\text{W}/\text{cm}^2$ can adversely affect the eyes and skin. Safety goggles designed to absorb UV wavelength radiation are suggested where high intensity blacklight is used.
 - 23.1.9 *Materials and Concentrates*—The safe handling of magnetic particles and concentrates are governed by the supplier's Material Safety Data Sheets (MSDS). The MSDS conforming to 29 CFR 1910.1200 or equivalent must be provided by the supplier to any user and must be prepared in accordance with FED-STD-313.

24. Precision and Bias

- 24.1 The methodology described in the practice will produce repeatable results provided:
 - 24.1.1 The strength of the magnetic flux field in the part/piece is confirmed and,
 - 24.1.2 The field has the proper orientation with respect to the discontinuities being sought.
- 24.2 It must be recognized that the surface condition of the material being examined, the material's magnetic properties, its shape, and control of the factors listed in 20.1 influence the results obtained.

25. Keywords

25.1 dye; evaluation; examination; fluorescent; inspection; magnetic particle; nondestructive; testing

ANNEX

(Mandatory Information)

A1. TYPICAL MAGNETIC PARTICLE INDICATIONS

A1.1 Surface discontinuities with few exceptions produce sharp and distinct magnetic particle indications. Near-surface discontinuities on the other hand produce less distinct or fuzzy magnetic particle indications in comparison to surface discontinuities; the magnetic particle indications are broad rather than sharp and the particles are less tightly held.

A1.2 Wet Method:

A1.2.1 *Fluorescent*— Indications of surface cracks, surface indications, and an indication of a near surface discontinuity are shown in Figs. A1.1-A1.6.



FIG. A1.1 Indications of Surface Cracks (Produced by Central Conductor DC Magnetization)

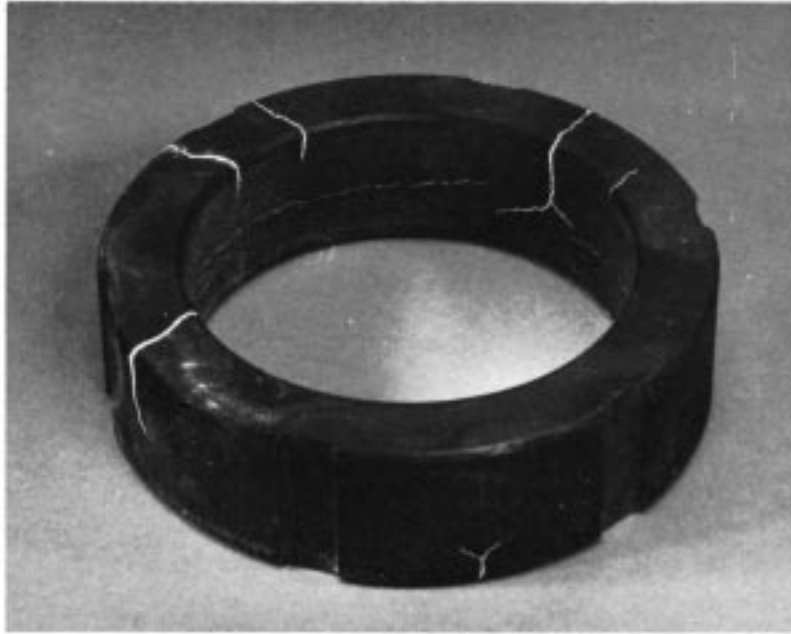

FIG. A1.2 Indications of Surface Cracks (Produced by Central Conductor DC Magnetization)



FIG. A1.3 Indications of Surface Cracks (Produced by Central Conductor DC Magnetization)

A1.2.2 *Nonfluorescent*— Indications of surface cracks are shown in Figs. A1.7-A1.16.

A1.3 *Dry Method*—Indications of surface cracks are shown in Figs. A1.17-A1.23.

A1.4 Nonrelevant indications are shown in Figs. A1.24-A1.26.



FIG. A1.4 Surface Indications (Produced by Central Conductor DC Magnetization)

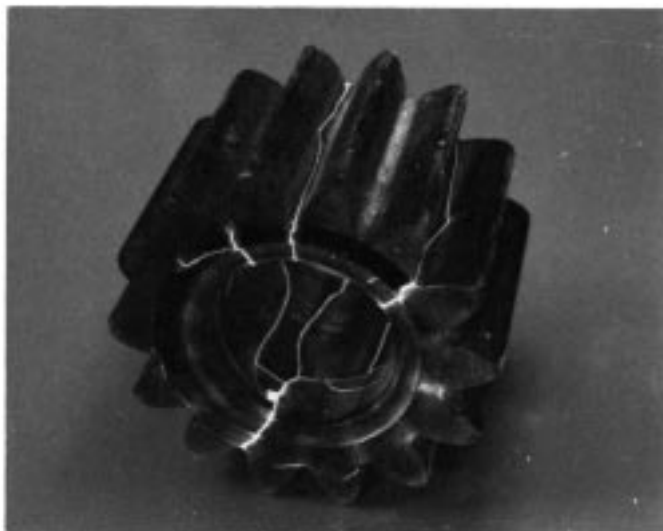

FIG. A1.5 Indications of Surface Cracks (Produced by Circular Magnetization DC Continuous)

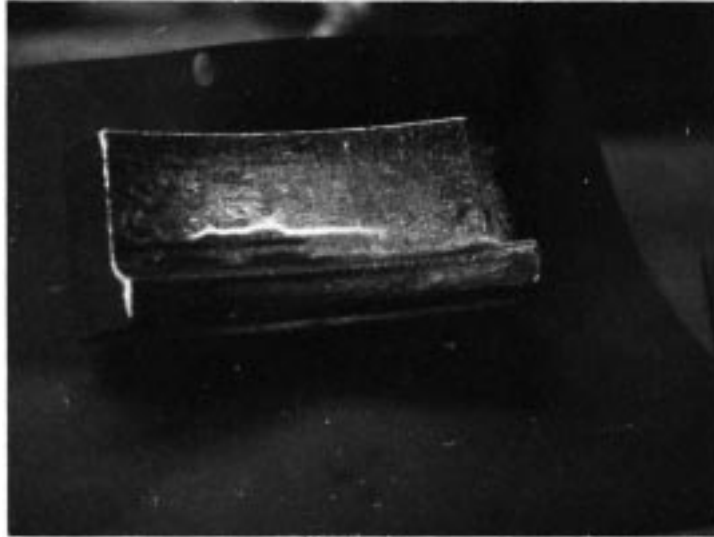

FIG. A1.6 Indication of a Near-Surface Discontinuity (Produced by Prod Magnetization)

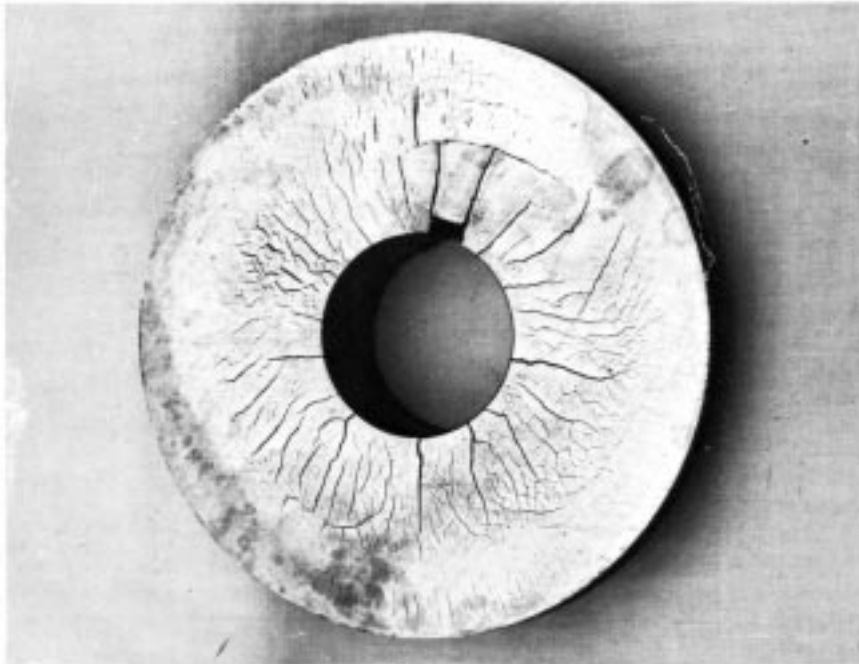

FIG. A1.7 Indications of Surface Cracking (Produced by Central Conductor Magnetization DC Continuous)



FIG. A1.8 Indications of Surface Cracking (Produced by Circular Direct Magnetization DC Continuous)

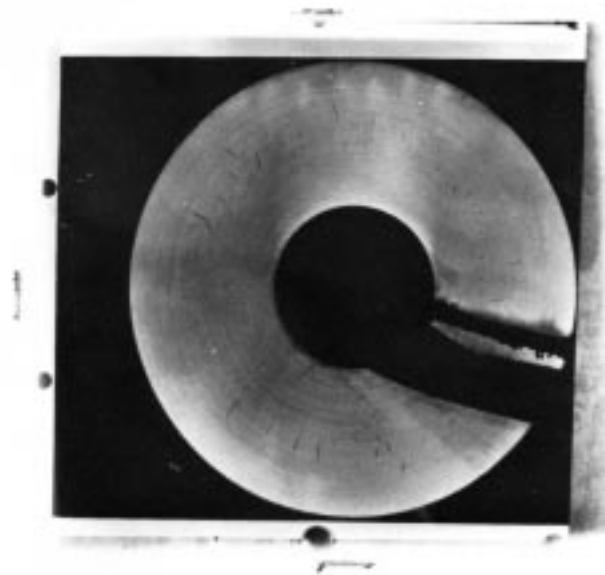

FIG. A1.9 Indications of Surface Cracks (Produced by Central Conductor Magnetization DC Continuous)



FIG. A1.10 Indications of Surface Cracks (Produced by Circular Indirect Magnetization DC)

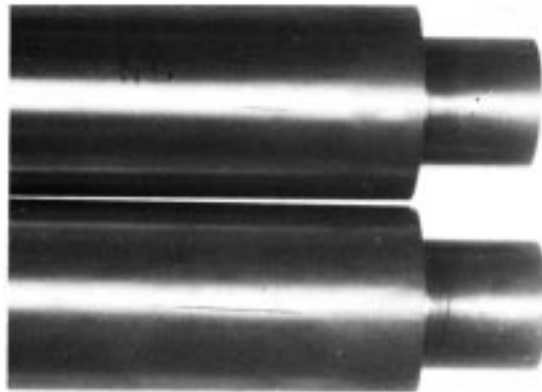

FIG. A1.11 Indications of a Near-Surface Discontinuity (Produced by Circular Direct Magnetization AC Continuous)

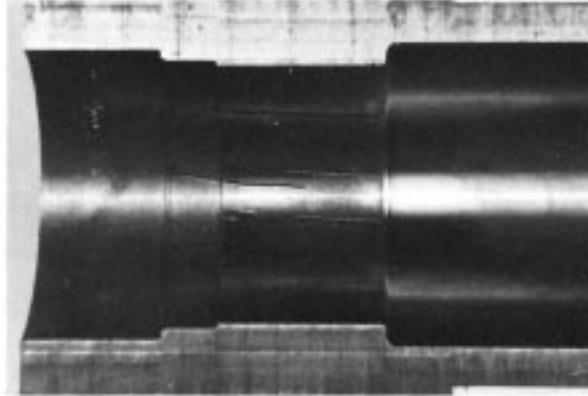

FIG. A1.12 Indications of Near-Surface Indications (Produced by Circular Direct Magnetization AC Continuous)

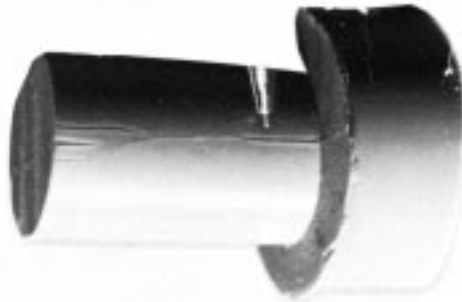

FIG. A1.13 Magnetic Rubber Indications of Surface Cracks in Aircraft Fastener Holes (Produced by Yoke Magnetization DC Continuous)



FIG. A1.14 Magnetic Rubber Indications of Surface Cracks in Aircraft Fastener Holes (Produced by Yoke Magnetization DC Continuous)

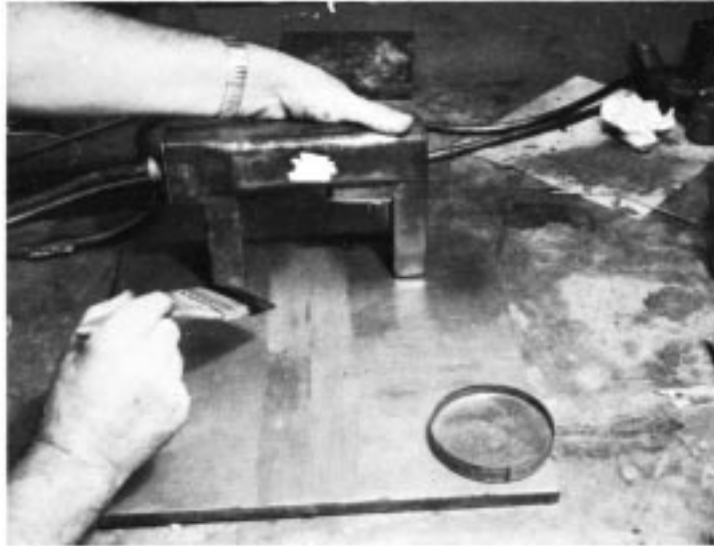

FIG. A1.15 Magnetic Slurry Indications of Surface Cracks in Weldment (Produced by Yoke Magnetization, AC Continuous)

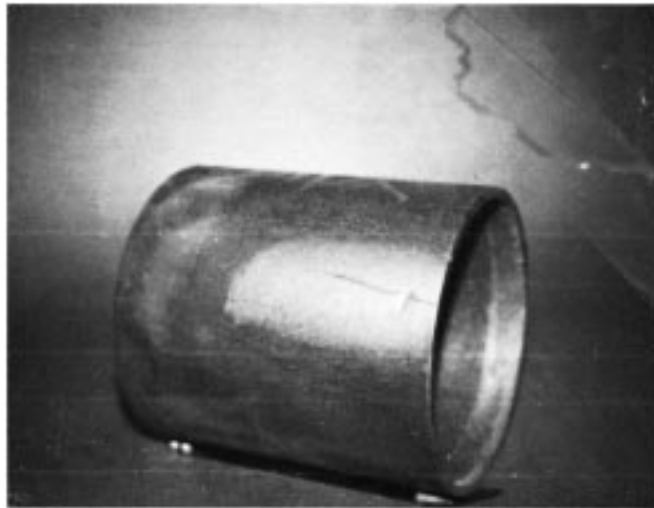

FIG. A1.16 Magnetic Slurry Indications of Surface Cracks (Produced by Yoke Magnetization, AC Continuous)



FIG. A1.17 Indications of a Near-Surface Discontinuity (Produced by Prod Magnetization, HWDC Continuous)



FIG. A1.18 Indications of a Near-Surface Discontinuity (Produced by Prod Magnetization, HWDC Continuous)

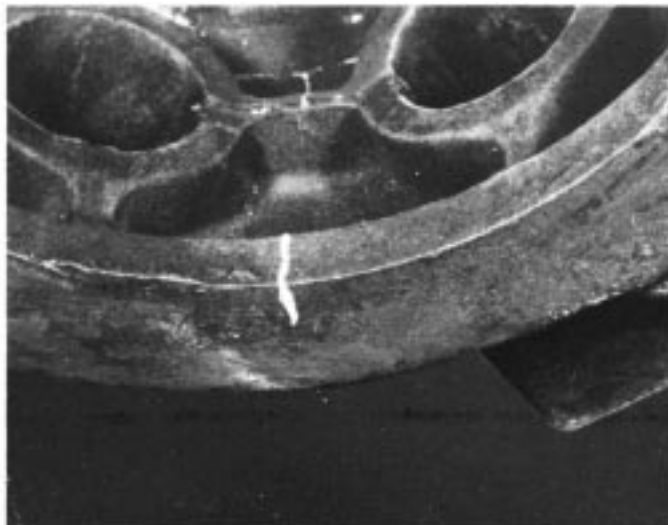

FIG. A1.19 Indication of Surface Cracks (Produced by Circular Indirect Magnetization, AC Continuous)

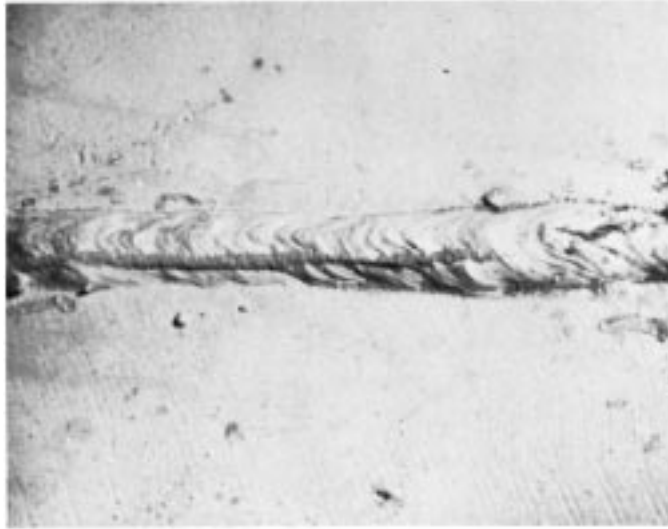

FIG. A1.20 Indication of Surface Cracks (Produced by Prod Magnetization, AC Continuous)

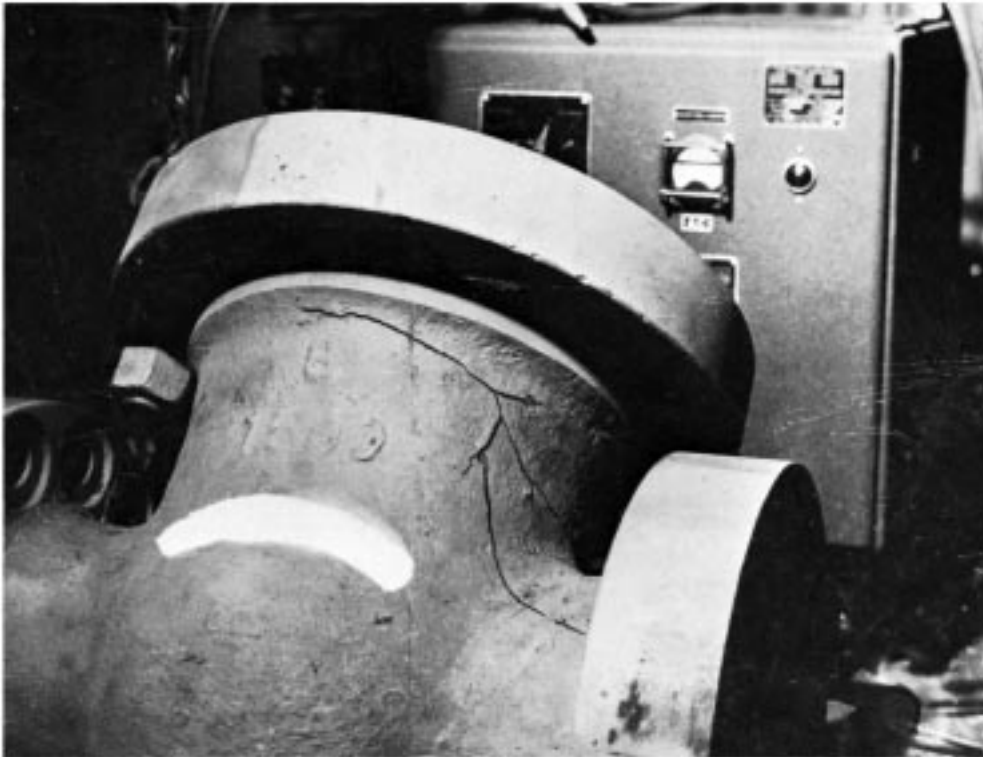

FIG. A1.21 Indications of Surface Cracks (Produced by Prod Magnetization, DC Continuous)



FIG. A1.22 Indications of Surface Cracks (Produced by Circular Direct Magnetization, AC Continuous)



FIG. A1.23 Indications of Surface Cracks (Produced by Central Conductor Magnetization, AC Continuous)



FIG. A1.24 Nonrelevant Indications of Magnetic Writing
(Produced by Direct Magnetization, DC Continuous)

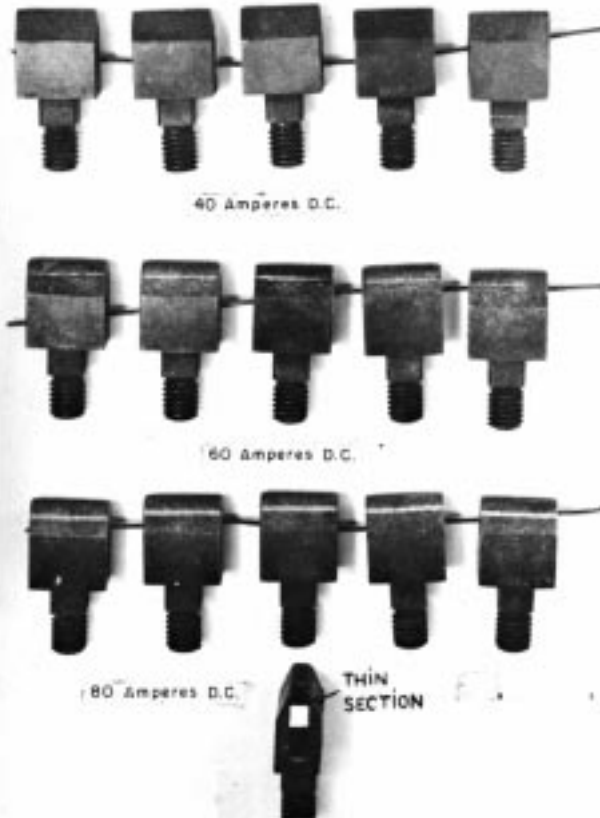

FIG. A1.25 Nonrelevant Indications Due to Change in Section on
a Small Part (Produced by Indirect, Circular Magnetization, DC
Continuous)

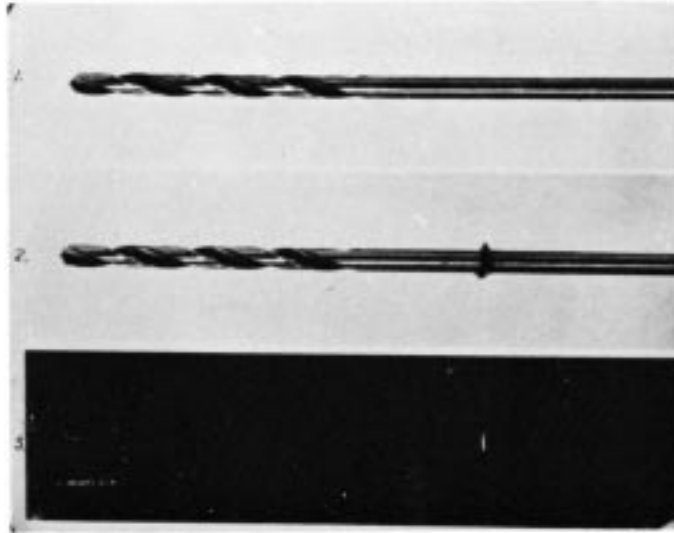

FIG. A1.26 Nonrelevant Indications of Junction Between Dissimilar Materials (Produced by Coil DC Residual Magnetization)

APPENDIXES

(Nonmandatory Information)

X1. REFERENCE STANDARD NOTCHED SHIMS FOR MAGNETIC PARTICLE EXAMINATION PER AS 5371

X1.1 The following standard flawed shims are typically used to establish proper field direction and ensure adequate field strength during technique development in magnetic particle examination. The shims of Fig. X1.1 may be used to ensure the establishment and balance of fields in the multidirectional magnetization method.

X1.1.1 The shims are available in two thicknesses, 0.002 in. (0.05 mm) and 0.004 in. (0.10 mm). Thinner shims are used when the thicker shims cannot conform to the part surface in the area of interest.

X1.1.2 The shims are available in two sizes, 0.75 in. (19 mm) square for Figs. X1.1 and X1.2 and 0.79 in. (20 mm) square of Fig. X1.3. The shims of Fig. X1.3 are cut, by the user, into four 0.395 in. (10 mm) square shims for use in restricted areas.

X1.1.3 Shims shall be low carbon steel, AMS 5062 or equivalent.

X1.1.4 Shims shall be used as specified in AS 5371. Shims are placed in the area(s) of interest with notches toward the surface of the part being examined. Use enough shims or place the shims in multiple areas to ensure proper field directions and strengths are obtained.

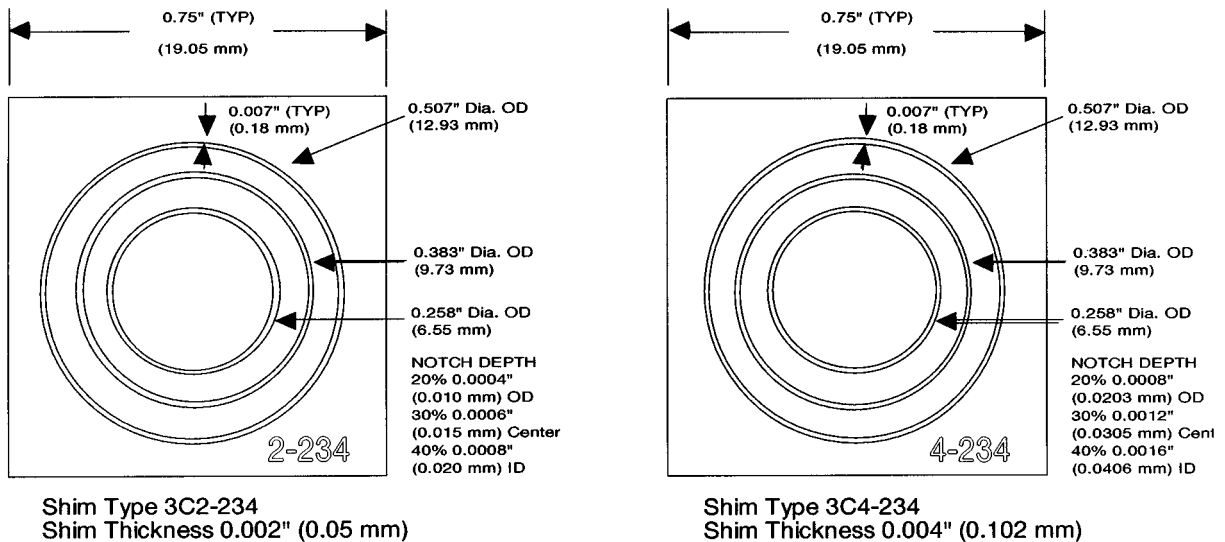

FIG. X1.1 Shim Thicknesses for Shim Types 3C2-234 and 3C4-234

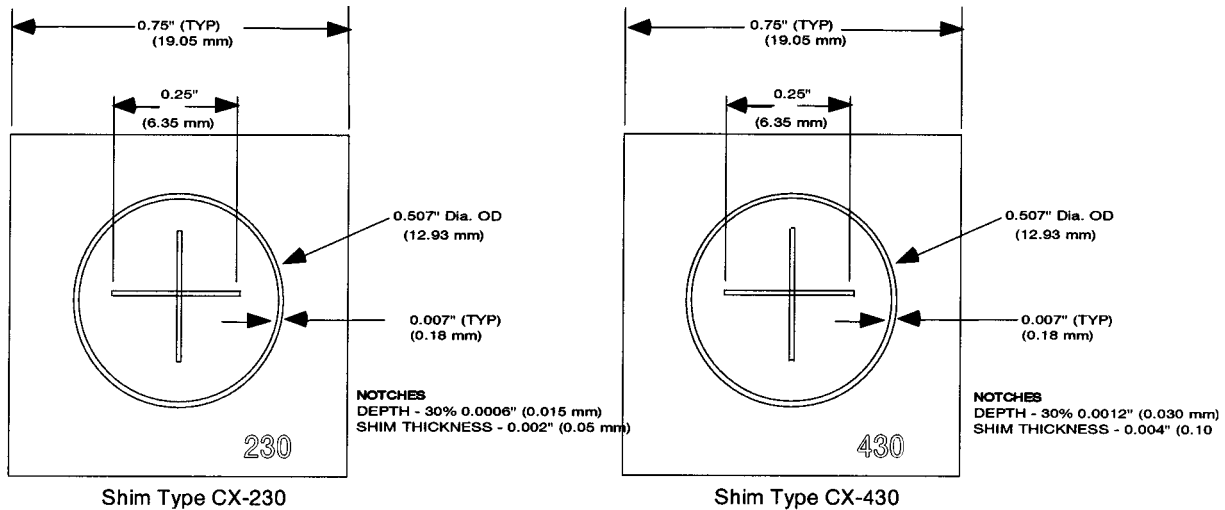

FIG. X1.2 Shim Types CX-230 and CX-430

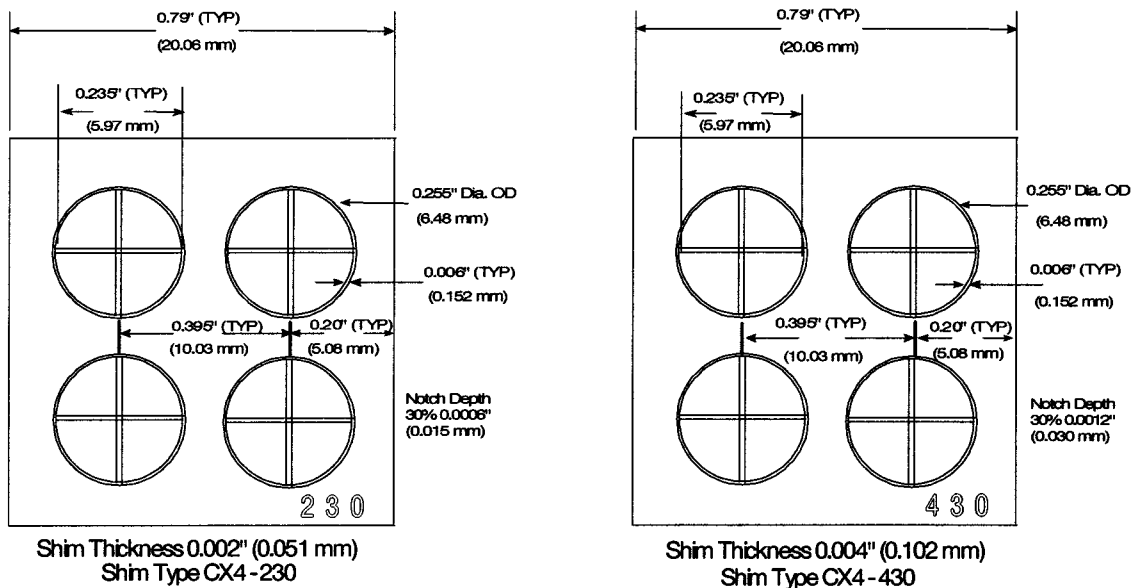

FIG. X1.3 Shim Thicknesses for Shim Types CX4-230 and CX4-430

X2. DEVICES FOR EVALUATION OF MAGNETIC PARTICLE EXAMINATION MATERIALS

X2.1 Scope

X2.1.1 The purpose of this appendix is to describe the capabilities and use of various devices that may be utilized to monitor and evaluate the performance of materials and systems for magnetic particle examination.

X2.2 Magnetic Stripe Cards. The magnetically encoded pattern in magnetic stripes, as on cards used for personal banking, identification and other purposes, can serve as a tool to evaluate magnetic particle inspection materials. Particles are attracted to the magnetic gradients formed in the stripe when the stripe has been magnetically encoded with a pattern of flux reversals. The encoding of the stripe can be controlled to provide gradients of varying magnitude. Particles can be evaluated for sensitivity when observed to see how small a gradient can generate a particle indication.

X2.3 Characteristics

X2.3.1 Magnetic stripe cards shall be made in accordance with ISO 7810– Identification Cards— Physical Characteristics.

X2.3.2 The stripe may be made of either low-coercivity (lo-co) or high-coercivity (hi-co) material, as designated by the manufacturer.

X2.3.3 A constant encoding pattern, decaying encoding pattern, reverse decaying pattern or other pattern may be encoded into the stripe. See Fig. X2.1 photograph of fluorescent particle indications of decaying and reverse decaying encoding patterns.

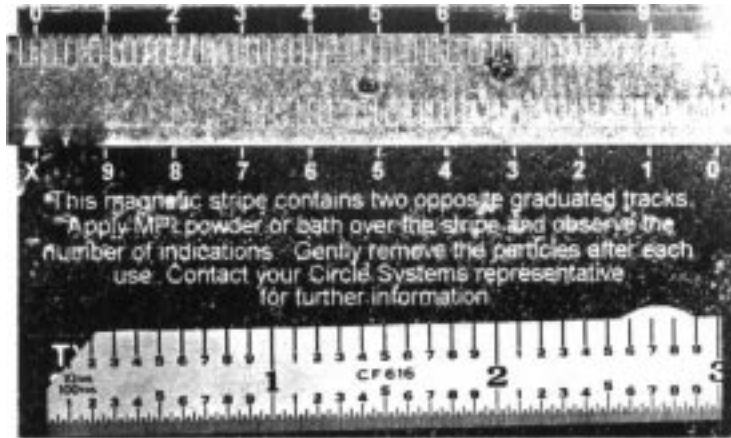

FIG. X2.1 Example of fluorescent particle indications of a decaying encoding pattern (top track) and a reverse-decaying pattern (bottom track) on the magnetic stripe of a magnetic stripe card.

X2.4 Use of the Magnetic Stripe Card for Magnetic Particle Material Evaluation

X2.4.1 Wet Method Materials—Wet method materials may be poured, sprayed or otherwise applied to the stripe, as they would be used for MPI. Excess bath shall be allowed to flow away from the stripe. The stripe shall be observed under suitable illumination (See Section 7) for the formation of particle indications. Observations shall be noted as to the quantity of particle indications and the clarity thereof.

NOTE X2.1—Dark colored non-fluorescent particles may be more readily observed with the use of a white contrast paint applied over the stripe prior to particle evaluation. Particle indications may also be observed and/or permanently recorded per Section 17 (Paragraph 17.1.2 can apply to wet method powder after the fluid has been allowed to evaporate.).

X2.4.2 Dry Method Materials—Dry method materials shall be poured, dusted, blown or otherwise applied to the stripe, as they would be used for MPI. Excess powder shall be removed with a gentle blowing action. The stripe shall be observed under suitable illumination (See Section 7) for the formation of particle indications. Observations shall be noted as to the quantity of particle indications and the clarity thereof. Refer to Note X2.1 for dark colored particles.

X2.4.3 Recording of Indications—Recorded particle indications (See 17.1.2) may serve as material documentation records and standards for material performance. Other material, or the same material at a later time, can be compared at any time to the recorded standard.

X2.5 Loss of Indications on the Stripe—There are several circumstances where particle indications may not be visible on the magnetic stripe. When indications are not visible the subject particles shall not be used for inspection unless otherwise verified as being acceptable.

X2.5.1 Concentration—The subject wet method particles may not have a sufficient level of concentration. In this case, increase the concentration level of the bath and re-perform the test until the particles demonstrate suitable performance.

X2.5.2 Sensitivity—The subject particles may not provide necessary sensitivity. In this case, replace the material with a suitably sensitive material and re-perform the test until the particles demonstrate suitable performance.

X2.5.3 Erasure—The stripe has become magnetically erased. In this case, no discernible particle indication will appear. In this case, repeat the test with another card and/or sensitivity test until the particles demonstrate suitable performance. Either destroy the card with the de-encoded stripe or report it to the manufacturer and follow the manufacturer's recommendations.

X2.6 Precautions

X2.6.1 Preparation—The surface of the stripe must be clean of any fluid or foreign matter prior to the application of the MPI material. The encoded stripe shall not be re-magnetized in any manner prior to use or de-magnetized in any manner following its use.

X2.6.2 Storage—The surface of the stripe should be cleaned of remaining fluid and particles after the observations of the MPI material have been made. When not in use, the card should be stored away from excessive heat and strong magnetic fields.

ASTM International takes no position respecting the validity of any patent rights asserted in connection with any item mentioned in this standard. Users of this standard are expressly advised that determination of the validity of any such patent rights, and the risk of infringement of such rights, are entirely their own responsibility.

This standard is subject to revision at any time by the responsible technical committee and must be reviewed every five years and if not revised, either reapproved or withdrawn. Your comments are invited either for revision of this standard or for additional standards and should be addressed to ASTM International Headquarters. Your comments will receive careful consideration at a meeting of the responsible technical committee, which you may attend. If you feel that your comments have not received a fair hearing you should make your views known to the ASTM Committee on Standards, at the address shown below.

This standard is copyrighted by ASTM International, 100 Barr Harbor Drive, PO Box C700, West Conshohocken, PA 19428-2959, United States. Individual reprints (single or multiple copies) of this standard may be obtained by contacting ASTM at the above address or at 610-832-9585 (phone), 610-832-9555 (fax), or service@astm.org (e-mail); or through the ASTM website (www.astm.org).