



# Standard Test Method for High-Frequency (10 kHz-1 MHz) Core Loss of Soft Magnetic Core Components at Controlled Temperatures Using the Voltmeter-Ammeter-Wattmeter Method<sup>1</sup>

This standard is issued under the fixed designation A 1013; the number immediately following the designation indicates the year of original adoption or, in the case of revision, the year of last revision. A number in parentheses indicates the year of last reappraisal. A superscript epsilon ( $\epsilon$ ) indicates an editorial change since the last revision or reappraisal.

## 1. Scope

1.1 This test method covers the equipment, procedures, and measurement of core loss of either toroidal or mated soft magnetic core components, such as soft ferrite cores, iron powder cores, and so forth, over ranges of controlled ambient temperatures typically from  $-20$  to  $+120^{\circ}\text{C}$ , frequencies from 10 kHz to 1 MHz, under sinusoidal flux conditions.

1.2 *This standard does not purport to address all of the safety concerns, if any, associated with its use. It is the responsibility of the user of this standard to establish appropriate safety and health practices and determine the applicability of regulatory limitations prior to use.*

1.3 The values and equations stated in customary (cgs-emu and inch-pound) of SI units are to be regarded separately as standard. Within this test method, SI units are shown in brackets except for the sections concerning calculations where there are separate sections for the respective unit systems. The values stated in each system may not be exact equivalents; therefore, each system shall be used independently of the other. Combining values from the two systems may result in nonconformance with this standard.

## 2. Referenced Documents

### 2.1 ASTM Standards:

A 34/A 34M Practice for Sampling and Procurement Testing of Magnetic Materials<sup>2</sup>

A 340 Terminology of Symbols and Definitions Relating to Magnetic Testing<sup>2</sup>

E 177 Practice for Use of the Terms Precision and Bias in ASTM Test Methods<sup>3</sup>

## 3. Terminology

3.1 The definitions of terms, symbols, and conversion factors relating to magnetic testing, used in this test method, are found in Terminology A 340.

## 3.2 Definitions of Terms Specific to This Standard:

3.2.1 *bifilar transformer*—a transformer in which the turns of the primary and secondary windings are wound together side by side and in the same direction. This type of winding results in near unity coupling, so that there is a very efficient transfer of energy from primary to secondary.

3.2.2 *core-loss density,  $P_{cd}$* —core loss per unit volume in  $\text{mW}/\text{cm}^3$  [ $\text{W}/\text{m}^3$ ].

3.2.3 *effective permeability*—the relative permeability of a magnetic circuit including the effect of air gaps in the magnetic path length.

3.2.4 *mated core set*—two or more core segments assembled with the magnetic flux path perpendicular to the mating surface.

## 4. Significance and Use

4.1 This test method is designed for testing of either toroidal or mated soft magnetic core components over a range of temperatures, frequencies, and flux densities.

4.2 The reproducibility and repeatability of this test method are such that it is suitable for design, specification acceptance, service evaluation, and research and development.

## 5. Apparatus

5.1 The apparatus shall consist of as many of the component parts as shown in the block circuit diagrams (Figs. 1 and 2) and described as follows and in the appendix, as required to perform the tests.

5.2 *Signal Generator*—A low distortion sine wave signal generator is required. The frequency accuracy of the signal generator should be within  $\pm 0.1\%$  with an output amplitude range from 1-mV to 10-V p-p.

5.3 *Broadband Power Amplifier*, capable of amplifying the output of the signal source by 50 dB.

5.4 *Volt-Amp-Watt Meter with Current Transformer*, ac-coupled, broadband, power factor independent, true RMS reading instrument. Voltage channel minimum input impedance 1 M $\Omega$ , voltage range from 2 to 100 V, current ranges from 5 mA to 5A, power ranges from 100 mW to 500 W. The full-scale accuracy of the wattmeter shall not exceed 0.75 % of the product of the input voltage and current ranges.

<sup>1</sup> This test method is under the jurisdiction of ASTM Committee A06 on Magnetic Properties and is the direct responsibility of Subcommittee A06.01 on Test Methods.

Current edition approved Oct. 10, 2000. Published January 2001.

<sup>2</sup> *Annual Book of ASTM Standards*, Vol 03.04.

<sup>3</sup> *Annual Book of ASTM Standards*, Vol 14.02.

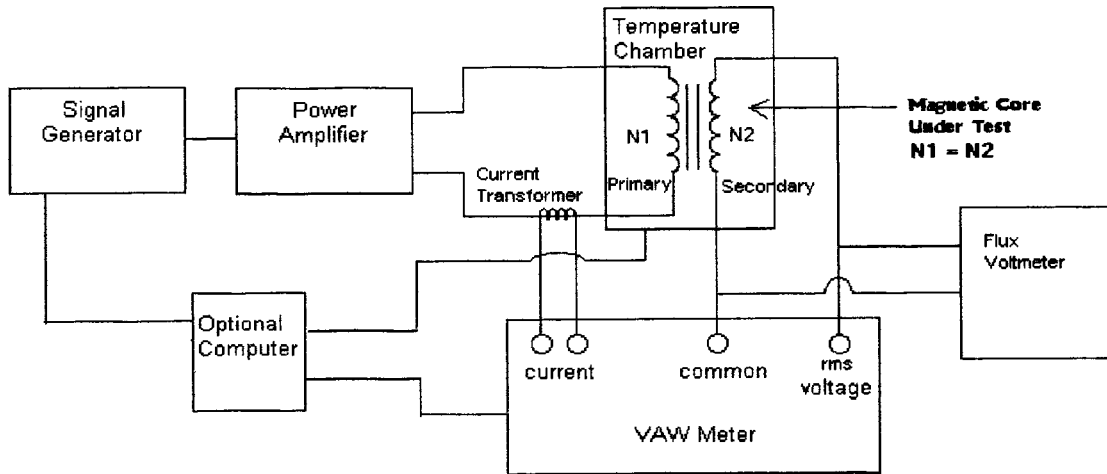

FIG. 1 Basic Circuit for VAW Meter Method Using Primary and Secondary Windings

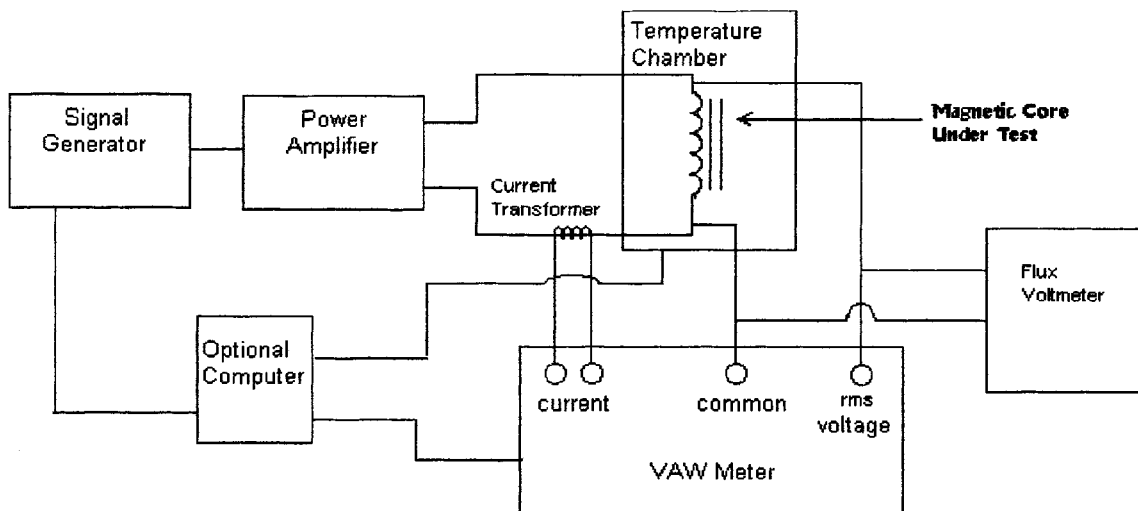

FIG. 2 Optional Circuit for VAW Meter Method Using One Winding Only (See 7.1)

5.5 *Flux Voltmeter*—A full-wave true-averaging voltmeter with scale reading in average volts times 1.111 so that its indications will be identical with those of a true rms voltmeter on a pure sinusoidal voltage. Input impedance of at least 2 M $\Omega$ . To produce the estimated precision of test under this test method, the full-scale meter errors shall not exceed 0.25 %.

5.6 *Temperature Chamber*, heated with electric elements, cooled by injecting liquid CO<sub>2</sub> or liquid nitrogen into the air stream through an expansion nozzle or equivalent methods.

5.7 *Temperature with Platinum RTD or Type T Thermocouple*.

5.8 *Optional*—Personal computer with appropriate I/O to control equipment and collect data.

## 6. Test Core Component

6.1 The test core component can be of any magnetic material (soft ferrite, iron powder, and so forth). The effective permeability of the material must be sufficiently high so that the test core component can be driven to the desired flux density with the available test equipment (within the power amplifier limitations).

6.2 When testing for material properties, the cross-sectional area of the test core component shall be uniform throughout its entire magnetic path length. The core may be of any shape. Shapes with nonuniform cross-sectional areas within their magnetic path length can be tested for specific core shape performance comparisons; however, the core-loss density will not be accurate, since the flux density and core loss vary throughout the magnetic path length and are not uniform.

6.3 Mated core set assembled around a prewound coil can be used, as well as toroidal cores.

6.3.1 Mating surfaces must be ground smooth and flat to minimize air gaps. Air gaps cause reluctance in the flux path and cause flux to fringe, both of which contribute to higher measured losses.

6.3.2 Clamping pressure for the mated core set needs to be sufficient to hold the cores together with minimum air gaps but not so strong that it affects the properties of the material through the creation of stress-magnetostriction anisotropy. A pressure of 5 lb/in.<sup>2</sup> [35 kPa] is recommended where the area is the area of the mating surfaces.

6.4 The length of test leads from the measuring instruments to the test core component should be minimized. The test leads should be twisted pairs to minimize magnetic pickup. The test lead capacitance can be significant at high frequencies and contributes to inaccuracy in the measurements.

## 7. Procedure

7.1 Prepare the test core component in the form of a transformer by applying windings to a toroid or for a mated core set by winding a bobbin and then assembling the magnetic cores around it. In either case, the winding should be single layer, wound as a bifilar transformer, and distributed evenly around the winding length. The number of turns is based on the maximum voltage available from the power amplifier calculated using Eq 6. If sufficient wire size (>600 circular mil/amp [0.30 mm<sup>2</sup>/amp]) is used, the winding losses are negligible; therefore, the secondary of Fig. 1 may be eliminated. Voltages can then be measured across the primary as shown in the optional circuit diagram (Fig. 2).

7.2 Place the test core component in the temperature chamber and attach it to the test equipment.

7.3 Set the chamber temperature. Sense the temperature of the core material by imbedding a platinum RTD or Type T thermocouple into a block of material similar to the material under test and with a cross-sectional area equal to or larger than the test core component. Some materials, such as ferrite, are poor thermal conductors and therefore may take considerable time to reach the ambient temperature (20 min for a 0.5- by 0.5-in. [12.7- by 12.7-mm] cross-sectional area is common).

7.4 Use Eq 6 to calculate the flux voltage for the desired flux density. Set the signal generator to the desired frequency then adjust the output so that the flux voltmeter indicates the value of voltage calculated to give the desired test induction. The voltage waveform must be sinusoidal to ensure that the power measurements are accurate. The simplest way to verify that the voltage waveform is sinusoidal is to observe that the flux voltmeter and the RMS voltmeter indicate equal values within  $\pm 1\%$ , showing that the form factor of the voltage is 1.111.

7.5 For core loss determinations, read and record the power from the wattmeter. Core loss density can be calculated using Eq 7.

## 8. Calculation (Customary Units)

8.1 The effective dimensional core parameters of the test specimen are computed by normalizing the core area ( $A$ ) throughout the core's magnetic path length ( $l$ ). Core constants  $C_1$  and  $C_2$  are calculated and used to calculate effective magnetic path length ( $l_1$ ), effective core cross-sectional area ( $A_e$ ), and effective core volume ( $V_e$ ), as follows:

$$\text{Core constant, } C_1 = \sum_1^n \frac{l_n}{A_n} \text{ cm}^{-1} \quad (1)$$

$$\text{Core constant, } C_2 = \sum_1^n \frac{l_n}{A_n^2} \text{ cm}^{-3} \quad (2)$$

$$\text{Effective magnetic path length, } l_1 = \frac{(C_1)^2}{C_2} \text{ cm} \quad (3)$$

$$\text{Effective core cross-sectional area, } A_e = \frac{C_1}{C_2} \text{ cm}^2 \quad (4)$$

$$\text{Effective core volume, } V_e = \frac{(C_1)^3}{(C_2)^2} \text{ cm}^3 \quad (5)$$

8.2 Calculate flux voltage as follows:

$$E_f = \sqrt{2} \pi B A_e N_2 f \times 10^{-8} \quad (6)$$

where:

$E_f$  = flux voltage induced in winding  $N_2$ , V;

$B$  = peak flux density, G;

$A_e$  = effective cross-sectional area of the test core component, cm<sup>2</sup>;

$N_2$  = number of turns of secondary winding; and

$f$  = frequency, Hz.

8.3 Calculate specific core loss density as follows:

$$P_{cd} = \frac{P_C}{V_e} \quad (7)$$

where:

$P_{cd}$  = core loss density, mW/cm<sup>3</sup>;

$P_C$  = core loss, mW; and

$V_e$  = effective core volume, cm<sup>3</sup>.

## 9. Calculation (SI Units)

9.1 The effective dimensional core parameters of the test core component are computed by normalizing the core area ( $A$ ) throughout the core's magnetic path length ( $l$ ). Core constants  $C_1$  and  $C_2$  are calculated and used to calculate effective magnetic path length ( $l_1$ ), effective core cross-sectional area ( $A_e$ ), and effective core volume ( $V_e$ ), as follows:

$$\text{Core constant, } C_1 = \sum_1^n \frac{l_n}{A_n} \text{ m}^{-1} \quad (8)$$

$$\text{Core constant, } C_2 = \sum_1^n \frac{l_n}{A_n^2} \text{ m}^{-3} \quad (9)$$

$$\text{Effective magnetic path length, } l_1 = \frac{(C_1)^2}{C_2} \text{ m} \quad (10)$$

$$\text{Effective core cross-sectional area, } A_e = \frac{C_1}{C_2} \text{ m}^2 \quad (11)$$

$$\text{Effective core volume, } V_e = \frac{(C_1)^3}{(C_2)^2} \text{ m}^3 \quad (12)$$

9.2 Calculate flux voltage as follows:

$$E_f = \sqrt{2} \pi B A_e N_2 f \quad (13)$$

where:

$E_f$  = flux voltage induced in winding  $N_2$ , V;

$B$  = peak flux density, T;

$A_e$  = effective cross-sectional area of the test core component, m<sup>2</sup>;

$N_2$  = number of turns of secondary winding; and

$f$  = frequency, Hz.

9.3 Calculate specific core loss density as follows:

$$P_{cd} = f \frac{P_C}{V_e} \quad (14)$$

where:

- $P_{cd}$  = core-loss density, [W/m<sup>3</sup>];
- $P_C$  = core loss, W; and
- $V_e$  = effective core volume, m<sup>3</sup>.

## 10. Report

- 10.1 Report the following information:
  - 10.1.1 Core component identification,
  - 10.1.2 Test frequencies,
  - 10.1.3 Test magnetic flux densities,
  - 10.1.4 Test temperature, and
  - 10.1.5 Test results (core loss density).

## 11. Precision and Bias

11.1 *Test Program*—Nine independent laboratories performed core-loss measurements on a common MnZn ferrite toroid using this test method. The core loss was measured at an induction of 1 kG [0.1 T], a frequency of 25 kHz, and at 25°C. This data plus an experiment to determine repeatability at one laboratory were used to develop the following precision information.

11.2 *Precision*—The precision is as follows:

	Core Loss, W	Percent of Value
Average test value:	0.246	...
95 % repeatability limit (within laboratory)	0.008	3.25
95 % reproducibility limit (between laboratories)	0.055	22.4

The preceding terms (repeatability and reproducibility) are used as specified in Practice E 177. These values are used for the comparison of two test results, both of which are single measurements. The respective standard deviations among test results may be obtained by dividing the preceding values by 2.8.

11.3 *Bias*—Since there is no accepted reference material, method, or laboratory suitable for measuring the magnetic properties determined using this test method, there is no statement of bias.

## 12. Keywords

12.1 alternating current; core; core loss; core test; ferrite core; high frequency; magnetic material; magnetic test; sinusoidal; soft ferrite; volt-amp-watt

## APPENDIX

### (Nonmandatory Information)

#### X1. EQUIPMENT LIST FOR APPARATUS SHOWN IN FIGS. 1 AND 2

X1.1 The following equipment list for the apparatus shown in Figs. 1 and 2 is included for information only and does not imply an endorsement of the particular equipment manufacturers nor limit the use of comparable equipment.

- X1.1.1 *Signal Generator*—HP 3225B or equivalent.
- X1.1.2 *Broadband Power Amplifier*—ENI 2100L or equivalent.
- X1.1.3 *Volt-Amp-Watt Meter with Current Transformer*—Clarke-Hess Model 258 or equivalent.

X1.1.4 *Flux Voltmeter*—Fluke 8810A with ac converter option 008 or equivalent.

X1.1.5 *Temperature Chamber*—Delta Design Model 9064 or equivalent.

X1.1.6 *Temperature Meter with Platinum RTD or Type T Thermocouple*—Newport 269 digital pyrometer or equivalent.

X1.1.7 *Optional*—Personal computer with appropriate I/O to control equipment and collect data.

*ASTM International takes no position respecting the validity of any patent rights asserted in connection with any item mentioned in this standard. Users of this standard are expressly advised that determination of the validity of any such patent rights, and the risk of infringement of such rights, are entirely their own responsibility.*

*This standard is subject to revision at any time by the responsible technical committee and must be reviewed every five years and if not revised, either reapproved or withdrawn. Your comments are invited either for revision of this standard or for additional standards and should be addressed to ASTM International Headquarters. Your comments will receive careful consideration at a meeting of the responsible technical committee, which you may attend. If you feel that your comments have not received a fair hearing you should make your views known to the ASTM Committee on Standards, at the address shown below.*

*This standard is copyrighted by ASTM International, 100 Barr Harbor Drive, PO Box C700, West Conshohocken, PA 19428-2959, United States. Individual reprints (single or multiple copies) of this standard may be obtained by contacting ASTM at the above address or at 610-832-9585 (phone), 610-832-9555 (fax), or service@astm.org (e-mail); or through the ASTM website (www.astm.org).*