



Designation: A 893 – 97

## Standard Test Method for Complex Dielectric Constant of Nonmetallic Magnetic Materials at Microwave Frequencies<sup>1</sup>

This standard is issued under the fixed designation A 893; the number immediately following the designation indicates the year of original adoption or, in the case of revision, the year of last revision. A number in parentheses indicates the year of last reapproval. A superscript epsilon ( $\epsilon$ ) indicates an editorial change since the last revision or reapproval.

### 1. Scope

1.1 This test method covers the measurement of the complex dielectric constant of isotropic ferrites for extremely high-frequency applications.

1.2 The values stated in either customary units or SI units are to be regarded separately as standard. Within the text, the SI units are shown in brackets. The values stated in each system are not exact equivalents; therefore, each system shall be used independently of the other. Combining values from the two systems may result in nonconformance with this specification.

1.3 *This standard does not purport to address all of the safety concerns, if any, associated with its use. It is the responsibility of the user of this standard to establish appropriate safety and health practices and determine the applicability of regulatory limitations prior to use.*

### 2. Summary of Test Method

2.1 In an isotropic dielectric medium with a steady electric field,  $E$ , the electric displacement,  $D$ , is given by the equation:

$$D = k\epsilon_0 E \quad (1)$$

where:

$\epsilon_0$  = permittivity of free space and

$k$  = dielectric constant. If the medium is subjected to an alternating electric field, the electric displacement is not necessarily in phase with the field. This fact may be expressed mathematically by taking  $k$  as a complex quantity. If we write  $k = k' - jk''$ , the imaginary part,  $k''$ , determines the dissipation in the medium.

2.2 This test method uses a cavity perturbation technique as a means of separating electric from magnetic effects. Quantities that must be measured are the resonance frequency,  $f$ , of the cavity with and without the sample, the loaded  $Q$  of the cavity with and without the specimen, and the cavity and specimen dimensions.

2.3 The specimen is in the form of a rod and is placed parallel to the microwave electric field in a region of substan-

tially uniform electric and zero microwave magnetic fields. The perturbation theory requires that the diameter of the sample rod be small compared to one quarter of the wavelength of the microwave radiation in the specimen. Estimation of this wavelength requires knowledge of the permittivity,  $\epsilon = k\epsilon_0$ , and permeability,  $\mu$ , of the specimen under the conditions of measurement. The wavelength,  $\lambda$ , in the specimen is given by the equation:

$$\lambda = 1/f'(\mu\epsilon)^{1/2} \quad (2)$$

For many ferrites,  $\mu$  may be taken equal to  $\mu_0$ , the permeability of empty space, without serious error. The permittivity,  $\epsilon$ , is determined by measurement as described below; after obtaining a value of  $\epsilon$ , it is necessary to ascertain with the aid of Eq 1 that the sample diameter is sufficiently small.

2.4 This test method is not suitable for materials with loss tangents  $\geq 0.1$ , with the loss tangent defined as  $\tan \delta = k''/k'$ .

2.5 The results of the perturbation theory calculation may be expressed in the form:

$$\delta f/f = [-(k-1) |Miv_s E^o E^i dv| / 2 |Miv_c (E^o)^2 dv] \quad (3)$$

where:

$f$  =  $f' + jf''/2Q$ ;

$Q$  = loaded  $Q$  of the cavity;

$v_s$  = specimen volume contained within the cavity, in.<sup>3</sup> [mm<sup>3</sup>];

$v_c$  = cavity volume, in.<sup>3</sup> [mm<sup>3</sup>]; and

$E$  = microwave electric field strength.

The superscript  $o$  refers to fields in the empty cavity and the superscript  $i$  refers to fields inside the specimen.

2.6 A specific cavity suitable for this test method is a TE<sub>10n</sub> rectangular cavity,<sup>2</sup> where  $n$  is odd. With the rod running completely across the cavity at the center, Eq 2 for  $\delta f/f$  can be reduced to the following:

$$\delta f'/f' = -2(k' - 1)(v_s/v_c); \delta(1/Q) = 4k''(v_s/v_c) \quad (4)$$

$\delta f'$  and  $\delta(1/Q)$  are, respectively, the difference in the cavity resonant frequency with and without the specimen and the difference in the reciprocal  $Q$  of the cavity with and without the specimen, and  $f'$  is the resonant frequency of the empty cavity.

<sup>1</sup> This test method is under the jurisdiction of ASTM Committee A-6 on Magnetic Properties and is the direct responsibility of Subcommittee A06.01 on Test Methods.

Current edition approved Oct. 10, 1997. Published December 1998. Originally published as C 525 – 63 T. Last previous edition F 131 – 86 (1991).

<sup>2</sup> See, for example, Montgomery C. G., Ed., *Technique of Microwave Measurements*, McGraw-Hill Book Co., Inc., New York, 1947, pp. 294–295; Bronwell and Beam, *Theory and Application of Microwaves*, McGraw-Hill Book Co., Inc., 1947, pp. 368–337.

2.7 In many cases it is convenient to describe the dissipative properties of the medium by alternative notation. An effective resistivity at the frequency  $f' = \theta/2\pi$  may be defined by the equation:

$$\rho = 1/\omega k'' \epsilon_0 \tag{5}$$

### 3. Significance and Use

3.1 This test method can be used to evaluate batch type or continuous production of material for use in microwave applications. It may be used to determine the loss factors of microwave ferrites or help evaluate absorption materials for use in microwave ovens and other shielding applications.

3.2 The values obtained by use of this practice can be used as quality assurance information for process control, or both, when correlated to the chemistry or process for manufacturing the material.

### 4. Apparatus

4.1 Fig. 1 is a schematic diagram of the equipment required for the measurement. Power from a suitable unmodulated or amplitude modulated microwave source, *A*, is run through a variable attenuator, *D*, and kept at a constant level throughout the measurement with the aid of a directional coupler, *E*, a crystal detector, and a power-indicating meter, *F*. This constant power is run through a precision variable attenuator, *G*, to the cavity, *H*, and the cavity output power is detected and indicated on a suitable meter, *I*.

### 5. Test Specimen and Cavity

5.1 The specimen shall be in the form of a rod. It is inserted in a transmission-type cavity so that the axis of the rod is along a line of constant microwave electric field and zero microwave magnetic field. The ends of the rod shall pass through holes in both cavity walls.

5.2 The rod diameter shall be 0.041 + 0.000, - 0.002 in. [0.10 + 0.00, - 0.05 mm] at X-band unless this violates the conditions of 2.3.

5.3 The input and output lines of this cavity shall be made to appear as matched loads by the appropriate use of pads or isolators.

5.4 The TE<sub>10n</sub> cavity (*n* odd and 3 or greater) shall be resonant between 9000 and 10 000 MHz for the X-band measurement. The loaded *Q* of the empty cavity shall be greater than 2000 (Note 1). The holes through which the ferrite passes shall be 0.042 + 0.002, - 0.000 in. [0.11 + 0.05, - 0.00 mm] in diameter. The dimensions of a typical cavity, operating in the TE<sub>103</sub> mode, are shown in Fig. 2.

NOTE 1—High *Q*s are obtainable by using waveguide and end plates of oxygen-free high-conductivity copper or by silver plating.

### 6. Procedure

6.1 Introduce an attenuation of 3 dB with the precision attenuator. Without the specimen in the cavity, adjust the microwave frequency to cavity resonance, as indicated by maximum power output with respect to frequency variation. Note the indication of the output power level and measure the resonant frequency,  $f'$ , with a wavemeter or other suitable means at *B*. Remove the 3 dB of attenuation and locate the two frequencies at which the output power is the same as at cavity resonance with the 3-dB attenuation in. Determine the separation in frequency of these two half-power points at *B* by a heterodyning technique using a frequency stabilized source, *C*. The loaded *Q* of the cavity is then given by  $f'/\Delta f' 1/2$  where  $\Delta f' 1/2$  is the frequency separation of the half-power points.

6.2 Alternatively, instead of the 3 dB of attenuation specified above, a larger amount,  $\alpha$  decibels, may be used. If  $\Delta f'$  is the separation of the two frequencies at which the output power without attenuation is the same as the output power at cavity resonance with the  $\alpha$  decibels of attenuation inserted, the *Q* is given by the equation:

$$Q = (f'/\Delta f') \sqrt{10^{\alpha/10} - 1} \tag{6}$$

6.3 By choosing a value of  $\alpha$  sufficiently large, it is possible to make the measurement of  $\delta f'$  with a precision wavemeter, eliminating the need of the heterodyning technique.

6.4 Position the specimen in the cavity and then repeat the measurements of  $f'$  and *Q*. The change in  $f'$  (a negative quantity) is the desired  $\delta f'$ , and the change in  $1/Q$  is the desired  $\delta (1/Q)$ . Nonzero microwave magnetic field at the specimen can introduce magnetic loss into this measurement. A

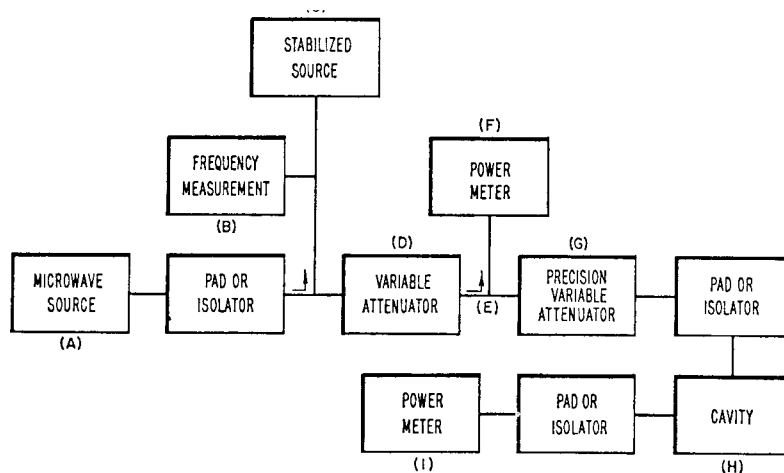

**FIG. 1 Schematic Diagram of Equipment Required for Measurement of Complex Dielectric Constant**

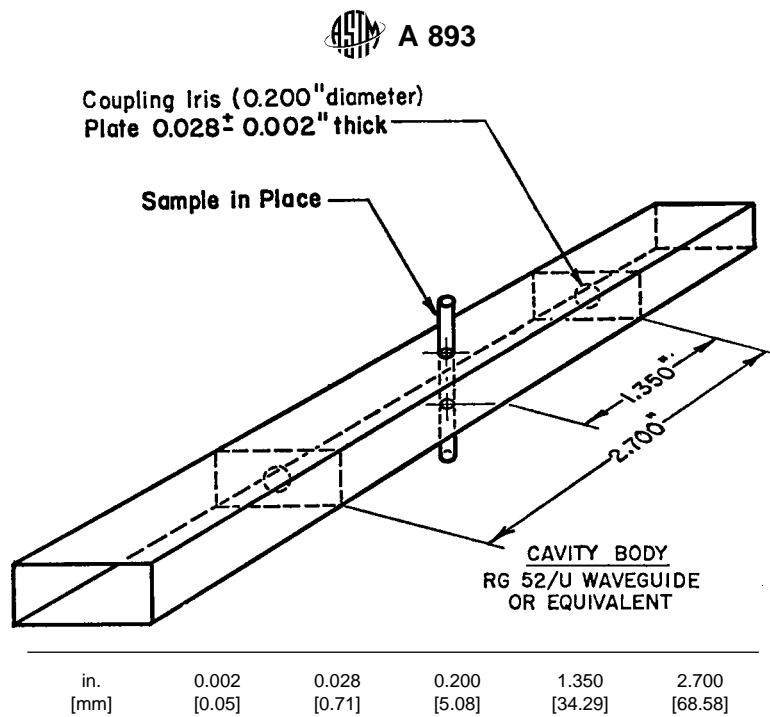

**FIG. 2 Typical Cavity for Measurement of Dielectric Constant at 9300 MHz**

suitable magnetic bias can be applied to the ferrite to avoid this loss contribution. The measurement of dielectric loss tangent must be independent of the applied magnetic field.

6.5 The recommended standard test temperature is  $25^{\circ}\text{C} \pm 5^{\circ}\text{C}$ .

## 7. Calculation

7.1 Calculate the values of  $k'$  and  $k''$  by means of Eq 3. Obtain the loss tangent, as defined in 2.4, from these values of  $k'$  and  $k''$ .

## 8. Report

8.1 The report shall include the following:

- 8.1.1 Values of  $k'$  and loss tangent,
- 8.1.2 Temperature of the material during the measurement,
- 8.1.3 Frequency at which the measurement was made,

8.1.4 Specimen diameter, and

8.1.5 Unique identity of the specimen.

## 9. Precision and Bias

9.1 The bias of the measurements shall be such that the error contributed to  $k'$  will be within  $\pm 3\%$  and the error contributed to the loss tangent will be within  $\pm 0.001$  or  $\pm 5\%$ , whichever is greater.

## 10. Keywords

10.1 absorption; dielectric; dielectric constant; ferrimagnetic; ferrite; loss factor; loss tangent; microwave; permittivity; shielding

*ASTM International takes no position respecting the validity of any patent rights asserted in connection with any item mentioned in this standard. Users of this standard are expressly advised that determination of the validity of any such patent rights, and the risk of infringement of such rights, are entirely their own responsibility.*

*This standard is subject to revision at any time by the responsible technical committee and must be reviewed every five years and if not revised, either reapproved or withdrawn. Your comments are invited either for revision of this standard or for additional standards and should be addressed to ASTM International Headquarters. Your comments will receive careful consideration at a meeting of the responsible technical committee, which you may attend. If you feel that your comments have not received a fair hearing you should make your views known to the ASTM Committee on Standards, at the address shown below.*

*This standard is copyrighted by ASTM International, 100 Barr Harbor Drive, PO Box C700, West Conshohocken, PA 19428-2959, United States. Individual reprints (single or multiple copies) of this standard may be obtained by contacting ASTM at the above address or at 610-832-9585 (phone), 610-832-9555 (fax), or service@astm.org (e-mail); or through the ASTM website (www.astm.org).*