



Standard Practices for Internal Reflection Spectroscopy¹

This standard is issued under the fixed designation E 573; the number immediately following the designation indicates the year of original adoption or, in the case of revision, the year of last revision. A number in parentheses indicates the year of last reapproval. A superscript epsilon (ϵ) indicates an editorial change since the last revision or reapproval.

1. Scope

1.1 These practices provide general recommendations covering the various techniques commonly used in obtaining internal reflection spectra.^{2,3} Discussion is limited to the infrared region of the electromagnetic spectrum and includes a summary of fundamental theory, a description of parameters that determine the results obtained, instrumentation most widely used, practical guidelines for sampling and obtaining useful spectra, and interpretation features specific for internal reflection.

2. Referenced Documents

2.1 ASTM Standards:

- E 131 Terminology Relating to Molecular Spectroscopy⁴
- E 168 Practices for General Techniques of Infrared Quantitative Analysis⁴
- E 284 Terminology of Appearance⁵

3. Terminology

3.1 *Definitions of Terms and Symbols*—For definitions of terms and symbols, refer to Terminologies E 131 and E 284, and to Appendix X1.

4. Significance and Use

4.1 These practices provide general guidelines for the good practice of internal reflection infrared spectroscopy.

5. Theory

5.1 In his studies of total reflection at the interface between two media of different refractive indices, Newton (**1**)⁶ discovered that light extends into the rarer medium beyond the

reflecting surface (see Fig. 1). In internal reflection spectroscopy, IRS, this phenomenon is applied to obtain absorption spectra by measuring the interaction of the penetrating radiation with an external medium, which will be called the sample (**2,3**). Theoretical explanation for the interaction mechanisms for both absorbing and nonabsorbing samples is provided by Snell's law, the Fresnel equations (**4**), and the Maxwell relationships (**5**).

NOTE 1—To provide a basic understanding of internal reflection phenomena applied to spectroscopy, a brief description of the theory appears in Appendix X2. For a detailed theoretical discussion of the subject, see (**4**).

6. Parameters of Reflectance Measurements

6.1 Practical application of IRS depends on many precisely controlled variables. Since an understanding of these variables is necessary for proper utilization of the technique, descriptions of essential parameters are presented.

6.2 *Angle of Incidence, θ* —When θ is greater than the critical angle, θ_c , total internal reflection occurs at the interface between the sample and the internal reflection element, IRE. When θ is appreciably greater than θ_c , the reflection spectra most closely resemble transmission spectra. When θ is less than θ_c , radiation is both refracted and internally reflected, generally leading to spectral distortions. θ should be selected far enough away from the average critical angle of the sample—IRE combination that the change of θ_c through the region of changing index (which is related to the presence of the absorption band of the sample) has a minimal effect on the shape of the internal reflection band. Increasing θ decreases the number of reflections, and reduces penetration. In practice, there is some angular spread in a focused beam. For instruments that utilize f4.5 optics in the sample compartment, there is a beam spread of $\pm 5^\circ$, but the beam spread in the IRE is smaller because of its refractive index. The value will increase as lower f-number optics are utilized. This beam spread produces a corresponding distribution of effective paths and effective depth of penetrations.

6.3 *Number of Reflections, N* — N is an important factor in determining the sensitivity of the IRE. Where multiple reflections are employed, internal reflection occurs a number of times along the length of the IRE depending on its length, l , thickness, t , and on the angle of incidence, θ , of the radiant beam.

NOTE 2—The length of an IRE is defined as the distance between the

¹ These practices are under the jurisdiction of ASTM Committee E-13 on Molecular Spectroscopy and are the direct responsibility of Subcommittee E13.03 on Infrared Spectroscopy.

Current edition approved April 10, 1996. Published June 1996. Originally published as E 573 – 76. Last previous edition E 573 – 90.

² Internal Reflection Spectroscopy, IRS, is the accepted nomenclature for the technique described in these practices. Other terms are sometimes used which include: Attenuated Total Reflection, ATR; Frustrated Total Reflection, FTR; Multiple Internal Reflection, MIR; and other less commonly used terms. In older literature, one may find references to Frustrated Total Internal Reflection, FTIR. This should not be confused with Fourier Transform Infrared Spectroscopy FT-IR.

³ Other terms sometimes used for referring to the internal reflection element are: ATR crystal, MIR plate, or sample plate.

⁴ *Annual Book of ASTM Standards*, Vol 03.06.

⁵ *Annual Book of ASTM Standards*, Vol 06.01.

⁶ The boldface numbers in parentheses refer to the list of references at the end of these practices.

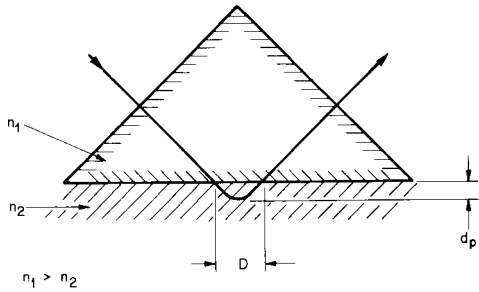

NOTE 1—The ray penetrates a fraction of a wavelength (d_p) beyond the reflecting surface into the rarer medium of refractive index n_2 (the sample), and there is a certain displacement (D) upon reflection. θ is the angle of incidence of the ray in the denser medium, of refractive index, n_1 , at the interface between the two media.

FIG. 1 Schematic Representation of Path of a Ray of Light for Total Internal Reflection

centers of the entrance and exit apertures.

6.3.1 Absorption occurs with each reflection (see Fig. 2), giving rise to an absorption spectrum, the intensity of which depends on N . For single-pass IREs, N can be calculated using the following relationship:

$$N = \left(\frac{l}{t}\right) \cot \theta \quad (1)$$

For double-pass IREs:

$$N = 2 \left(\frac{l}{t}\right) \cot \theta \quad (2)$$

Many single-pass IREs employ approximately 25 reflections.

NOTE 3— N must be an odd integer for IREs in the shape of a trapezoid, and an even integer for IREs in the shape of a parallelogram.

6.4 Relative Refractive Index, n_{21} , of the Sample, n_2 , and IRE, n_1 ; ($n_{21} = n_2/n_1$)—Refractive index matching controls the spectral contrast. If the indexes of the sample and the IRE approach each other, band distortions can occur. Therefore, it is necessary to select an IRE with a refractive index considerably greater than the mean index of the sample.

6.4.1 The refractive index of a material undergoes abrupt changes in the region of an absorption band. Fig. 3 (6) shows the change in refractive index of a sample across an absorption band as a function of wavelength. When an IRE of index n_A is selected, there may be a point at which the index of the sample is greater than that of the IRE. At this wavelength, there is no θ at which total internal reflection can take place, and nearly all of the energy passes into the sample. The absorption band resulting in this case will be broadened toward longer wavelengths, and hence appear distorted. When an IRE of index n_B is selected, there is no point at which the index of the sample exceeds it. On the long wavelength side, however, the refrac-

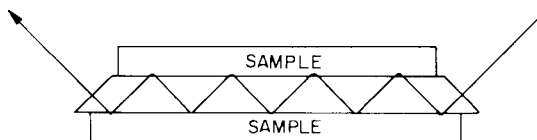
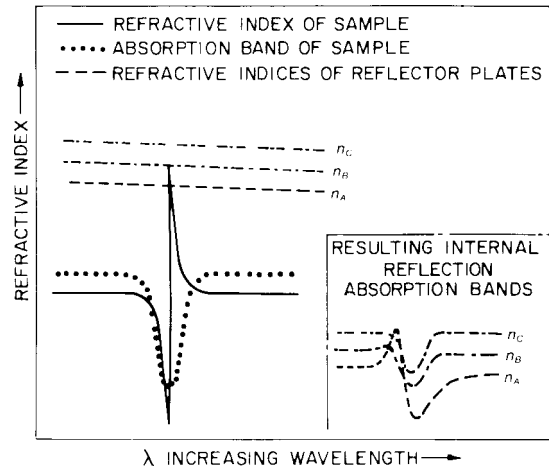

FIG. 2 Multiple Internal Reflection Effect



Solid Line—Refractive index of sample.
Dotted Line—Absorption band of sample.
Dashed Lines—Refractive indices of reflector plates.

FIG. 3 Refractive Index Versus Wavelength

tive indexes approach each other. This results in an absorption band that is less distorted, but that is still broadened on the long wavelength side. With an IRE of index n_C , a considerably higher refractive index than that of the sample, the index variation of the sample causes no obvious distortion of the absorption band.

6.5 Depth of Penetration, d_p —The distance into the rarer medium for which the amplitude of the penetrating radiation falls to e^{-1} of its value at the surface is a function of the wavelength of the radiation, the refractive indexes of both the IRE and the sample, and the angle of incidence of the radiation at the interface.

6.5.1 The depth of penetration, d_p , can be calculated as follows:

$$d_p = \frac{\lambda_1}{2\pi(\sin^2 \theta - n_{21}^2)^{1/2}} \quad (3)$$

where: $\lambda_1 = \frac{\lambda}{n_1}$ = wavelength of radiation in the IRE.

The depth of penetration increases as the angle of incidence decreases, and becomes infinitely large as θ approaches the critical angle (see Figs. 4 and 5) (7).

6.6 Effective Path Length, d_e —The effective pathlength, or relative effective thickness, d_e , for the beam for each reflection is defined by Harrick (4) in detail, and is different for \perp -polarized than for \parallel -polarized radiation. For bulk materials, when $\theta = 45^\circ$, $d_{e\perp} = \frac{1}{2} d_{e\parallel}$, and the average effective thickness is about equal to the penetration depth, d_p . For larger angles, d_e is smaller than d_p and for smaller angles, d_e is larger than d_p . The total effective pathlength is equal to N times the effective pathlength, d_e . An example of the effect of θ on $N \cdot d_e$ is shown in Fig. 6.

6.7 Absorption Coefficient, α —As in transmission spectroscopy, the absorptivity of a material affects the fraction of the incident radiation that is absorbed, and hence the spectral contrast. The internal reflectance of bulk materials and thin films, for small absorptivities, is as follows:

$$R = 1 - \alpha d_e \quad (4)$$

The reflectance for N reflections is:

NO.	θ_c	n_{21}	NO.	θ_c	n_{21}
1	10°	174	9	50°	766
2	15°	259	10	55°	819
3	20°	342	11	60°	866
4	25°	423	12	65°	906
5	30°	500	13	70°	940
6	35°	574	14	75°	966
7	40°	643	15	80°	985
8	45°	707	16	85°	996

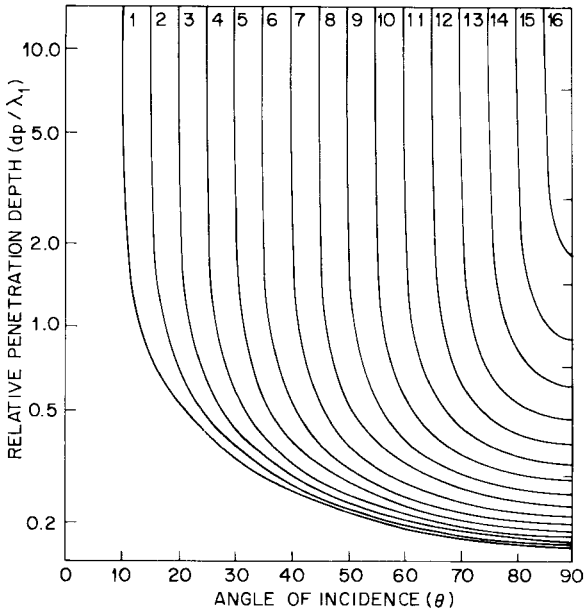

NOTE 1—Fractional penetration depth of electromagnetic field in rarer bulk medium for total internal reflection versus angle of incidence for a number of interfaces. The penetration depth is infinitely large at the critical angle and is about one tenth the wavelength at grazing incidence for relatively high index media. $\lambda_1 = \lambda/n_1$ is the wavelength in the denser medium.

FIG. 4 Relative Penetration Depth Versus Angle of Incidence

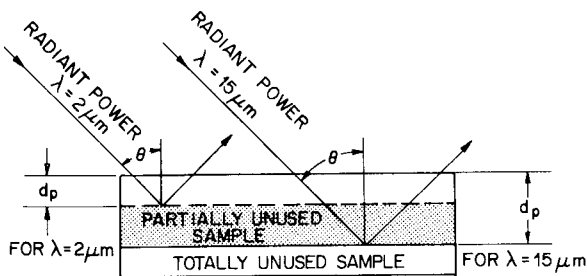

FIG. 5 Variation of Penetration Depth with Wavelength of Radiation in Sample (7)

$$R^N = (1 - \alpha d_e)^N \quad (5)$$

6.7.1 If $\alpha d_e \ll 1$, $R^N \approx 1 - N \cdot \alpha \cdot d_e$, that is, the reflection loss is increased by a factor of N . The relationships between the absorption coefficient, α , and the absorptivity, a , are given by Eq X2.13 and Eq X2.14.

6.8 Sampling Area—When multiple reflections are used, the sampling area is somewhat analogous to the pathlength in transmission spectroscopy. The amount of absorption by a sample in contact with a multiple-reflection IRE is proportional to the area of contact within the sensitive region. Sampling area is proportional to $1/\cos \theta$ and increases with increasing θ .

6.8.1 The sensitive region of an IRE sampling face varies,

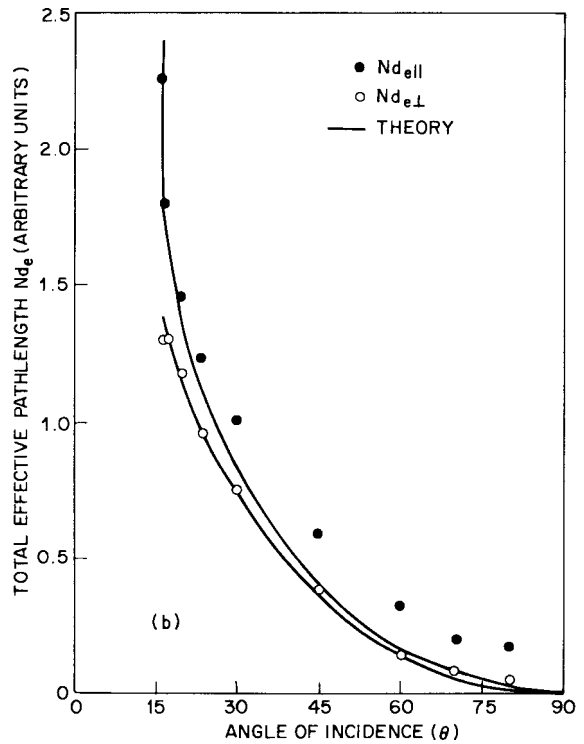

NOTE 1—Total effective pathlength versus angle of incidence for polystyrene stain on silicon surface. The sharp drop with angle of incidence is largely, although not entirely, due to decrease of N with θ . Points represent experimental measurements and solid curves are theoretical calculations (4).

FIG. 6 Total Effective Pathlength Versus Angle of Incidence

depending on the IRS system in which it is used. A small region or the entire area of the sampling faces can be sensitive, as seen for the dispersive systems shown in Fig. 7. It must be emphasized that, in general, there is no relationship between the size of the sensitive sampling area and the optical efficiency of the IRS system, provided that the slit height of the dispersive spectrophotometer is filled. In fact, it is preferred that an IRE have insensitive edges so that gasket materials or sample holders do not cause spectral interference. It is important that samples be positioned so that they lie completely across the width of the sensitive area. For accessories utilizing single-reflection prisms and hemicylinders, the entire sample face should be covered. If this area is not completely covered by the sample, radiation bypasses the sample and the effect will be similar to a transmission cell with an air bubble in it. Knowing the sensitive sampling area on an IRE is important when the sample is limited and it is desirable to place the sample on the IRE in the most efficient manner (8). The sensitive region of an IRE sampling face may differ quite radically when used in an

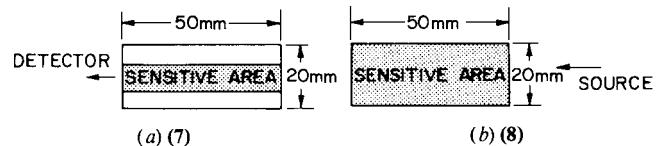

FIG. 7 Sensitive Sampling Areas of IRE Plates

interferometer. The focused image is nearly circular and may not fill the vertical dimension of the crystal but often will overfill the width of the IRE face. This results in vignetting and introduces small wavenumber errors in Fourier Transform spectroscopy. The problem of overfilling the entrance aperture can be minimized by utilizing beam condensing optics, but this will increase the angular spread of the incident rays.

NOTE 4—It is recommended that an IRE with a vertical dimension only slightly larger than the focused beam diameter be used. This ensures that the sensitive area encompasses the full crystal face.

6.9 *Efficiency of Contact*—In order to obtain an internal reflection spectrum, it is necessary to bring the sample to a distance within the penetration depth, d_p . Physical contact of the sample with the IRE may be sufficient to obtain a qualitative spectrum. However, if the exact contact conditions are not reproduced, a source of error may result, particularly when interpretation requires a direct comparison with similarly obtained spectra, or when quantitative measurements are made.

6.10 *Electric Field Strength*—Spectral contrast is affected by the strength of the electric field, that is, the amplitude of the standing wave, in the rarer medium at the reflecting interface between two media. The field strength of the \parallel -polarized component is greater than that of the \perp component, and both of these field strengths decrease with increasing θ .

7. Instrumentation

7.1 *Internal Reflection Attachments*—The internal reflection attachment, IRA, holds the IRE. It directs some portion of the radiation beam into the IRE, and then redirects the emerging energy into the spectrophotometer slits or onto the FT-IR detector without displacing or defocusing the beam while maintaining the same beam spread. The IRA is placed into the sampling compartment of a spectrometer. Most commercially available infrared spectrophotometers can be equipped with a reflection attachment for obtaining internal reflection spectra (Note 4). The optical efficiency of internal reflection infrared systems can be nearly equal to theoretical. However, in some IRAs only half of the spectrophotometer energy may be available. Schematic diagrams of two types of fixed-angle IRAs are presented in Fig. 8. For double-beam operation, it is preferred that an IRA identical to that used in the sample beam be used in the reference beam in order to compensate for surface scatter, atmospheric absorptions, or absorptions in the IRE. When using an IRA in a FT-IR

spectrometer, a reference spectrum (or background) is usually recorded using the same IRE with no sample in contact with the crystal. Very careful cleaning and sampling procedures (more than usual) are required here. Spectral verification of IRE cleanliness is essential. Internal reflection equipment includes the following:

7.1.1 The IRAs designed to be placed into the sampling compartment of a spectrophotometer. These are of the following types: (a) variable-angle single internal reflection; (b) fixed-angle multiple internal reflection (θ usually set at 45°), and (c) variable-angle multiple internal reflection (θ is either continuously variable, usually between 30 and 60° , or a choice of angles is preset by the manufacturer, usually at 30 , 45 , and 60° . In order to have the θ that is specified on the attachment, an IRE for that same θ must be used.) (d) platforms for supporting fixed-angle plates in a horizontal position, and (e) IRAs for supporting prism IREs of various geometry.

7.1.2 *Goniometers*—Goniometers are essential for absolute intensity measurements.

7.1.3 *Horizontal ATR Attachments*—This family of accessories is based on single-pass IRE geometries, which may be of fixed-angle or variable-angle construction. They are designed so that only one crystal face is accessible to the user in a horizontal plane. Some designs have the crystal set into the top surface of the accessory; others have a range of interchangeable plates, each with a different crystal material or sampling geometry. Plates are available to examine solid samples and often can accommodate a device to apply pressure to the sample. Other plates have a “boat” configuration and are designed to accept liquid samples. Some accessories are designed to vary the temperature of the sample.

7.1.3.1 The construction of horizontal IREs result in some potential problem areas for users. The crystal may be held in the plate by a fixing material, which may give spectral contributions. Liquid samples that are inhomogeneous (for example, engine oils) may suffer from separation or deposition of heavier components onto the surface of the crystal. This results in a spectrum that shows an excessive contribution from that material pressure applied to a sample by using a pressure plate and cannot easily be controlled. Use of pressure may cause some polymeric samples to exude semiliquid onto the plate.

NOTE 5—It is not the intention of this practice to specify any particular instrumentation for IRS. It is assumed that the equipment used is of the usual commercial quality and that the manufacturer's instructions will be consulted for proper IRA operation.

7.2 *Internal Reflection Elements*—Infrared radiation is propagated through the internal reflection element by total internal reflection. Where multiple reflections are employed, the long pathlengths required place stringent demands on both the quality and the preparation of optical materials for IREs. The geometries of more common types and the properties of the best optical materials are presented in 7.3 and 7.4. Additional information is available in the literature (4).

7.3 *Geometry*—Common IREs are classified as follows:

7.3.1 *Single-Reflection IREs* (Note 5):

7.3.1.1 Fixed-angle prisms (Fig. X3.1(a))

7.3.1.2 Variable-angle hemicylinders (Fig. X3.1(b)), and

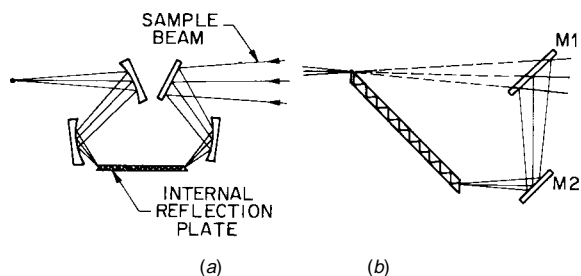

NOTE 1—(a) utilizes trapezoid IREs, and (b) utilizes parallelepiped IREs.

FIG. 8 Fixed-Angle Multiple-Reflection Internal Reflection Attachments

7.3.1.3 Micro hemicylinders.

NOTE 6—Prior to 1964, single-reflection IREs were the only type commercially available. They are still used, but principally for strongly absorbing materials. For weak absorbers, the angle of incidence must be set close to the critical angle and the kind of distortion depicted earlier (Fig. 3) can result.

7.3.2 *Multiple-Reflection IREs* (Diagrams of common types are shown in Fig. X3.1(c), (d), (e), (f), and (n)):

7.3.2.1 *Single-Pass IRE*—This is the simplest and most common. Radiation introduced through the entrance aperture propagates by multiple internal reflections down the length of the plate to the exit aperture. In these IREs, θ is generally fixed at 45° ; however, plates are available with θ fixed at any angle.

7.3.2.2 *Double-Pass IRE*—In this type, radiation propagates down the length of the plate and is reflected back upon itself by a metalized end reflecting surface. The beam returns at a slightly different angle of incidence. The average θ is usually between 45 and 50° .

7.3.2.3 *Variable-Angle Multiple Reflection Plates, Single- and Double-Pass* (Note 7)—Angle variation may be obtained by use of IRAs that have provisions for repositioning IREs at set angles of incidence. Where a knowledge of θ is not as important as the effect of angle change, fixed angle IREs may be used in any baseplate position to effect an angle change. For example, if a KRS-5 IRE with $\theta = 45^\circ$ is placed into an IRA position for $\theta = 60^\circ$, then the actual angle of incidence is 51.3° . If the value of θ must be known, it can be calculated using the following equation:

$$\theta = \theta_{IRA} - \sin^{-1} \left(\frac{\sin(\theta_{IRA} - \theta_{IRE})}{n_1} \right) \quad (6)$$

where:

- θ_{IRA} = angle of incidence of the IRA position,
- θ_{IRE} = angle of incidence of the IRE, and
- n_1 = refractive index of the IRE material.

NOTE 7—For further information on this subject, see (29).

7.3.2.4 *Cylindrical Internal Reflection Element, (CIRE)*, (Fig. X3.1(f))—The CIREs are made from polished cylinders of any suitable IRE material with polished conical ends. The cone angle will vary with the material used but should be roughly complimentary to the desired internal reflection angle. Although it is difficult to precisely describe the paths of all of the rays entering the entrance cone of the CIRE, empirical studies have shown that the equations for number of reflections (1), depth of penetration (3), reflection (5), and absorptions (appendix) hold with reasonable accuracy. The end face of the CIRE matches the circular shape of the FT-IR beam. When used with instruments that refocus the FT-IR beam on the cone ends at the proper angle, the CIRE performs efficiently because it utilizes the entire beam. The CIREs are useful for constructing liquid cells because they can be sealed into a sample chamber by means of O-rings. Such sealed cells can be made to withstand several hundred pounds of pressure.

7.3.2.5 *Prism Internal Reflection Element, (PIRE)* (Fig. X3.1(h))—The PIREs are polished fixed-angle, elongated, four-sided, double-pass prisms constructed from any suitable IRE material. These IRE's are usually mounted vertically in a chamber that can be used for liquid or solid powder sampling.

Liquid volume (when used as a sealed liquid cell) or immersion depth (when used as a probe by dipping the IRE into a powder or liquid sample) controls the number of reflections used. The throughput of a nine-reflection 45° angle double-pass ZnSe prism liquid cell is about 40 % at 4000 cm^{-1} and 50 % at 1000 cm^{-1} .

7.3.2.6 *Use of Optical Fiber as IRE*—If cladding is removed from a short length of an IR transmitting optical fiber, light passing through the fiber becomes an IRE. If that portion of the fiber is immersed in a liquid or resin sample, the spectrum of that material can be obtained.

7.4 *Optical Materials*—A perfect IRE material is not available because some of the desirable properties are mutually exclusive. Important characteristics of useful materials are:

- 7.4.1 High mean refractive index, preferably $n = 2.5$ to 3.5 ,
- 7.4.2 High transmittance and spectral purity,
- 7.4.3 Ability to take high polish,
- 7.4.4 Toughness and resistance to cold flow, permitting pressing and clamping to optimize contact, and
- 7.4.5 Chemical inertness, offering resistance to chemical attack by samples and cleaning materials.

NOTE 8—Properties of best available and most frequently used IRE materials appear in Table 1. For a more complete coverage of the wide range of optical materials suitable for fabricating IREs, consult (9) and (10)

NOTE 9—Coverage of all internal reflection instrumentation is beyond the scope of these practices. For more extensive coverage of the subject, see (4), (11), and (12).

8. Internal Reflection Elements

8.1 *Selection*—The refractive index of the IRE should be chosen so that measurements of bulk materials made at the desired θ will not yield distorted spectra. Lower index yields higher transmission because reflection losses at the entrance and exit faces are reduced. For thin films (less than 100 nm), the lowest possible index should be used so that distortion will be absent, while absorption will be enhanced. Hardness and inertness should also be considered. The system to be studied determines to some extent the choice of IRE material since the surfaces must not be attacked chemically. Ionizable acids and bases, for example, will etch the surface of KRS-5. Germanium and silicon, on the other hand, can be washed or soaked in dilute acids and alkalis.

8.2 *Evaluation*—The quality of an IRE is judged by its transmittance and the dependence of transmittance on wavelength. The maximum transmittance expected is determined by considering the reflection losses at the entrance and exit apertures. If only these losses are considered, then:

$$T_1 \approx (1 - R)^2 \quad (7)$$

where:

T_1 = transmittance of the IRE,

and at normal incidence for the entrance or exit beam:

$$R = \frac{(n_1 - 1)^2}{(n_1 + 1)^2} \quad (8)$$

Many IREs exhibit transmittances close to the maximum value predicted by Eq 8 even when as many as 100 reflections are employed.

TABLE 1 Properties of Typical Optical Materials for Internal Reflection Elements^A

Material	Useful Range, [μm] [cm ⁻¹]	Mean Refractive Index	Critical Angle, θ _c	Properties
Silver chloride	0.45–16 22 000–700	2.0	30	soft, moldable, light-sensitive, easily scratched, insoluble in water
Silver bromide	0.5–35 20 000–500	2.22	27	slightly harder than silver chloride, otherwise similar, insoluble in water and alcohol
Zinc sulfide	0.7–10 14 000–1000	2.22	27	relatively hard and inert, water insoluble, attacked by concentrated acids and bases
Diamond C	0.22–4; 6–FIR 45 000–2 500; 1 600–FIR	2.4	25	hard, expensive, permanent, insoluble in water, acids, and bases
KRS-5, thallos bromide iodide	0.7–40 14 000–250	2.35	24.6	relatively soft, convenient index, favorable combination of properties, soluble in warm water, soluble in bases; insoluble in acids
Zinc selenide	0.5–14.3 20 000–700	2.42	24.6	expensive, brittle, water insoluble, releases H ₂ Se, a toxic material when used with acids, soluble in strong acids, dissolves in nitric acid
Cadmium telluride	1.0–22 10 000–500	2.65	22.25	expensive, relatively inert, can be used with aqueous solutions, insoluble in acids
Arsenic triselenide	0.9–11.8 11 000–900	2.8	20.9	brittle, can be soaked in 35 % HCL, 95 % H ₂ SO ₄ , 10 % nitric acid, attacked by alkali, concentrated nitric acid and aqua regia
Silicon	1.06–6.7; 30–FIR 9 500–1 500; 350–FIR	3.5	15.6	hard, high resistivity material, useful at high temperatures, insoluble in most acids and bases, soluble in HF and HNO ₃
Germanium	2.0–11.4 5 000–900	4.0	14.5	limited range, sensitivity to temperature, becomes opaque at 125°C, insoluble in water, soluble in hot H ₂ SO ₄ and aqua regia, fine penetration depth
Sapphire	0.4–4.5	1.8	31.8	extremely hard, chemically resistant, low index, short transmission range
Cubic zirconia	0.4–5	2.1	27.3	extremely hard, chemically resistant, nontoxic, good index, relatively short transmission range

^A For various applications, a wide variety of optical materials have been employed as IREs. These materials include MgO, CaF₂, ZnS_{Se} (zinc-sulfo-selenide solid solution), NaCl, KCl, and KBr.

8.2.1 Reasons for Poor Performance:

8.2.1.1 *Poor Optical Material*—Defects in the quality of IRE materials are magnified because of the long pathlengths and large N s employed in IRS. Some pieces of KRS-5 exhibit internal haziness that contributes to energy losses, especially at shorter wavelengths. Other pieces are soft and soluble in organic solvents, leading to rapid deterioration of the surface.

8.2.1.2 *Inadequate Surface Polish*—This causes scattering losses for soft materials such as KRS-5. Harder materials like silicon and germanium are capable of excellent surface polishing, and seldom need reconditioning.

8.2.1.3 *Poor Tolerance on Lengths and Angles*—The length to thickness ratio, l/t , of the IRE controls N (usually θ is predetermined) (see Eq 1). In single-pass IREs, l/t is chosen so that the central ray enters and leaves by way of the entrance and exit apertures. If Eq 1 does not yield an integer, then a single incoming beam will yield two spatially separated beams at the exit aperture that partially or completely miss the exit aperture. (This occurs when the aperture is larger than the source image.) In double-pass IREs (Eq 2), loss of energy occurs if N is not an integer, since the beam might strike the entrance rather than the exit aperture, and so be directed back toward the source. In this case, the condition for optimum transmission can be satisfied by adjusting θ , provided that the instrumentation permits angle variation. The tolerances on all angles of the surfaces from which reflection occurs and through which light is transmitted are strict. This is especially true for high-index IREs, because, if the angle of the exit aperture is off by δ degrees, the exit beam is deflected away from the normal to that surface by $n\delta$.

8.2.1.4 *Nonparallelism*—If an IRE does not have parallel

surfaces, and the deviation from θ is by an angle δ , then after N reflections, θ within the IRE is changed by $N\delta$ for a single-pass plate. The exit beam will be deflected $n \cdot N\delta$ degrees away from the normal to the exit aperture. For double-pass IREs, nonparallelism is not as serious, because any change in θ as the beam traverses the IRE is compensated for in its return path. A wavy surface in either single- or double-pass IREs might not be serious if the average flatness is maintained.

8.2.2 *Quality Checks of an IRE*—Check the quality of an IRE by one or more of the following:

8.2.2.1 Visually inspecting for obvious surface or geometric defects,

8.2.2.2 Employing the IRE as a transmission plate to determine its optical purity,

8.2.2.3 Placing the IRE into a single-beam IRA in a dispersive spectrometer and measuring the transmitted power as a function of wavelength. Scattering, which goes roughly as λ^{-4} , is more severe at shorter wavelengths if the surface polish is inadequate. Spectra of IREs with good and bad surfaces are shown in Fig. 9. Very low overall transmittance of new IREs could indicate poor geometry or poor crystal structure,

8.2.2.4 Mounting the IRE on a goniometer and reflecting a highly collimated laser beam from the surface in question, then noting the angular displacements for flatness and poor tolerance on angles, and

8.2.2.5 Comparing with a reference IRE. When a double-beam internal reflection system is used, it is good practice to keep a previously tested high-quality IRE in the reference optics so that changes in a sample IRE can be readily observed.

8.2.3 Evaluating an IRE by comparing it with an unused reference IRE, using a double-beam internal reflection system,

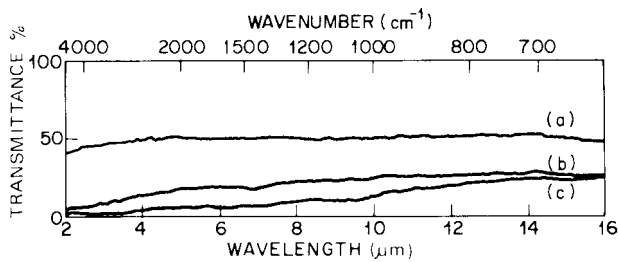

NOTE 1—Comparison of the transmittance versus wavelength for a number of KRS-5 single-pass plates with various qualities of surface polish; $N = 26$, $\theta = 45^\circ$. (a) Good polish; (b) hazy surface, needs resurfacing; (c) scratched, poor surface polish, needs repolishing. (Courtesy of G. D. Propster, Wilks Infrared Center, Foxboro Corp., South Norwalk, CT.)

FIG. 9 Comparison of Transmittance Versus Wavelength

requires that both the sample and reference beam IRAs be well-aligned. The sample-beam IRA must be realigned whenever a new (or refinished) IRE is to be checked and used because small differences of geometry always exist among IREs. An abbreviated procedure suffices for checking a used IRE in the IRA that had previously been aligned with it.

8.2.3.1 The procedure for evaluating a new IRE in a dispersive spectrophotometer in a double-beam internal reflection system is:

- (a) (a) Partially align the IRA-IRE optical system,
- (b) (b) Turn the 100 % control of the spectrophotometer to move the recorder pen downscale to about 50 % T ,
- (c) (c) Continue the alignment of the IRA to maximize transmitted energy, and
- (d) (d) Turn the 100 % control of the spectrophotometer to place the recorder pen at about 80 % T . Then run the IRE baseline.

8.2.3.2 The procedure for evaluating a used IRE is as follows:

- (a) (a) Use a previously aligned optical system, having a highquality IRE in the reference beam and no additional external reference beam attenuation,
- (b) (b) Place the IRE to be checked in the sample-beam IRA, and turn the 100 % control of the spectrophotometer to place the recorder pen at about 80 %, or as far upscale as possible if this is less than 80 %, and
- (c) (c) Record the baseline of the IRE.

8.3 Care and Handling of IREs—For optimal performance, it is necessary to maintain the cleanliness of the IRE. When cleaning sealed cells (see 10.3.7), chlorinated and ketone solvents should be used with caution, so that cements or glues are not attached. The particular properties of each crystal material dictate special handling precautions. Recommendations for care of most used IREs are as follows:

8.3.1 Germanium, Silicon, Zinc Selenide, and Zinc Sulfide—The IREs of these materials are hard and brittle, and subject to mechanical fracture. They do not scratch easily and rarely need repolishing. If necessary, they may be washed or soaked in water or in any organic solvents, without damage to optical properties.

8.3.2 KRS-5—This material is relatively soft, and it scratches and deforms fairly easily. Rough or hard samples

may dent or scratch the optical faces. The quality of this IRE is variable, some crystals being softer and hazier than others. Commercially available IREs of KRS-5 display wide variations in hardness and resistance to ketone solvents. The best optical materials are hard and insoluble in acetone solvent. Crystals that display acetone solubility scratch, deform, and lose surface polish easily. Warm water, ionizable acids and bases, chlorinated solvents, or amines should not be used on these IREs. Hydrocarbon solvents, ketones, alcohols, and cold water (for short intervals) may be used for cleaning.

NOTE 10—Regarding the toxicity of KRS-5 and KRS-6, no extraordinary hazard is encountered in normal handling as an IRE. Powdered or granular material which may be formed during grinding or polishing is dangerous since it may be ingested or absorbed through breaks in the skin.

8.3.3 Silver Chloride—Silver chloride (AgCl) is considerably softer than KRS-5, and much more flexible. The IREs of this material scratch easily, and if they are left in contact with metal over a few hours, a reaction occurs that damages both the IRE and the holder. For this reason, it is recommended that AgCl not come in contact with the metal holder. This material is light-sensitive and accumulates surface-oxidation products upon exposure to light and air which can be removed by washing a solvent-cleaned AgCl plate with a 0.2 % hypo solution. The AgCl has a low initial cost and it may be most economical to discard a worn AgCl IRE.

8.3.4 Sapphire—An extremely hard material, it is chemically resistant to both strong acids and bases. With a relatively low index (1.8) and short transmission range (to 4.5 μm) it is useful primarily in process applications where its nontoxicity and resistance to corrosive streams are important.

8.3.5 Cubic Zirconia—An extremely hard (third in the hardness scale) durable material, it is superior to sapphire in index (above 2) and transmission range (to 5 μm), and nearly equal in chemical resistance. It is nontoxic and suitable for process applications in foods and pharmaceuticals.

8.3.6 General Recommendations—Preservation of optical surfaces for all IRE materials can be accomplished as follows:

8.3.6.1 Removal of nonslippery solid coatings may be accomplished in the following manner: Place the pressure-sensitive side of an adhesive tape onto the sample across the length of the IRE. Apply light pressure on the release side of the tape with a finger. (This will not deform even the softest IREs since the tape acts as a cushion.) At an 180° angle, slowly peel the tape away from the IRE. Most nonslippery, resinous, elastomeric, and powdered samples are substantially removed by this technique.

8.3.6.2 For the removal of thin, organic films or residues that remain after the procedure in 8.3.4.1, flush the IRE with an appropriate solvent. For best results, a solvent wash bottle should be used for all washing operations. This avoids unnecessary handling of the crystal. For the removal of organic contaminants on germanium or silicon IRE surfaces, ultrasonic cleaning may be used, but caution must be used when cleaning KRS-5, as too much power damages this material. (Suggested cleaning time is 30 s.)

8.3.6.3 Dab an IRE to dryness with soft rayon balls. Do not rub. Soft IREs are scratched by many so-called soft tissues. These should be avoided for cleaning use. Many commercially

available rayon balls contain solvent extractables. To eliminate possible contamination of the IRE, wash the ball with the solvent used in the cleaning operation.

8.3.6.4 For the removal of fingerprints, saturate a soft rayon ball with cold water. Lightly wipe the contaminated area by dabbing the IRE surface. Drying of the IRE may be accelerated by flushing with reagent grade acetone, and then dabbing dry.

8.3.6.5 To determine the absence of residues, place the cleaned IRE into the IRA. Then scan through the range of the spectrophotometer. Residual organic materials are revealed by C—H, C—F, Si—O stretching, or carbonyl absorptions. Fingerprints are obvious by visual inspection, but if not noticed, they can cause spurious absorptions and overall reduction in transmitted spectral energy. If the spectrum indicates that the IRE is not clean, repeat 8.3.4.2 through 8.3.4.4.

8.3.6.6 If the procedure in 8.3.4.5 reveals a poor IRE baseline (see Fig. 9), with a 15 to 20 % transmittance in the shorter wavelength region for a single-beam IRA, or a 60 to 70 % transmittance in a double-beam IRA, then the IRE needs reconditioning to restore its optical properties. Using bad IREs leads to poorly resolved spectra caused by low energy transmission. The IRE reconditioning should be left to operators skilled in this art because there are precise geometric and optical polishing requirements, and some IRE materials are toxic.

9. Operation of Internal Reflection Attachments (29)

9.1 Operating conditions for individual IRAs are best obtained from the manufacturer's instructions. Some general procedures that apply to most commercial internal reflection instrumentation are (Note 11):

NOTE 11—It is assumed that the infrared spectrometer is operating properly. Performance of the instrument can be evaluated in accordance with Practice E 275.⁴ If radiation beam lengths are unequal, or if the source is bent, the baseline will exhibit atmospheric absorptions even when a double-beam IRA is properly aligned.

9.1.1 *Single-Beam IRA Used in a Dispersive Spectrophotometer:*

9.1.1.1 Set the spectrophotometer to transmit 100 % at 2000 cm^{-1} (5 μm).

9.1.1.2 Place the IRA into the sample compartment of the spectrophotometer with the IRE in position.

9.1.1.3 Align the optics in accordance with the manufacturer's instructions, so that the transmittance reading of the IRE is maximized. For new KRS-5, with $t = 2$ mm, $l = 50$ mm, and $\theta = 45^\circ$, the transmittance reading should be between 25 and 50 %.

9.1.1.4 Attenuate the reference beam, bringing the pen to an 85 or 95 % transmittance reading.

9.1.1.5 Check the pen response by interrupting the sample beam.

9.1.1.6 If pen response is low, increase the slit program or the gain setting, or both, until the desired response is obtained. The peak-to-peak noise level should be less than 2 % of full scale.

9.1.1.7 Run the IRE baseline through the full range of the spectrophotometer. The baseline should be flat within 5 % if the IRE is new.

9.1.1.8 Position the sample on the IRE. Recheck optical

alignment of the IRA before obtaining a spectrum, in order to compensate for any displacement of the IRE that might have occurred when positioning the sample.

9.1.2 *Double-Beam IRA Used in a Dispersive Spectrophotometer:*

9.1.2.1 Align the optics in accordance with the manufacturer's instructions. If more radiant power is transmitted through the reference IRE, the recorder pen will be deflected downscale, whereas an upward deflection indicates greater transmittance of the sample-beam IRE. Alignment of the reference optics should be continued until the pen no longer moves upscale. The central rays of both the sample and the reference beam should be parallel and have matched vertical displacements as they enter the photometer.

9.1.2.2 Set the desired transmittance reading using the spectrophotometer's 100 % control.

9.1.2.3 Record the baseline. If an optical imbalance is present, the baseline will exhibit atmospheric absorption bands. In this case, realign until the baseline is free of atmospheric absorptions.

9.1.2.4 Proceed in accordance with 9.1.1.5-9.1.1.8 for single-beam operation.

9.1.2.5 For best results, it is desirable to use matched IREs in the sample and the reference beam.

9.1.3 *Single-Beam IRA in an FT-IR Spectrometer:*

9.1.3.1 Place the IRA in the sample compartment and partially align with the internal alignment source, if available.

9.1.3.2 Monitor the system energy (for example, interferogram centerburst intensity, energy meter, or sample beam) and align in accordance with the manufacturer's instructions to maximize this signal. The signal should be 25 to 50 % of the signal observed with the IRA not present.

9.1.3.3 Record a background single-beam spectrum using a clean IRE.

9.1.3.4 Carefully remove the IRE and position a sample on it. Replace the IRE to the IRA as reproducibly as possible.

9.1.3.5 Record the sample single-beam spectrum, ratio against the background recorded in 9.1.3.3 to obtain a spectrum in transmittance units.

NOTE 12—A poor baseline (either low transmittance or highly sloped) may indicate loss of alignment between background and sample collection. This necessitates starting at 9.1.3.1 and repeating all steps through 9.1.3.5.

10. Sampling Techniques

10.1 Sampling is accomplished by placing the material of interest in contact with the reflecting surfaces of the IRE. Physical contact is generally sufficient for obtaining qualitative spectra. In general, smooth pliable samples such as rubber, films, coatings on soft substrates, and so forth, make excellent contact with slight pressure; thus only a small area of sample may be required for obtaining a suitable spectrum. If this is the case, the desired number of reflections can be selected by using only a small section of the IRE surface.

10.1.1 It is possible to obtain an identifiable spectrum of suitable spectral contrast by random placement of a sample onto the IRE. However, if a good quality spectrum with reproducible spectral features is desired, and less than the entire IRE is to be contacted, then the sample must be placed

across the width of the sample plate covering the sensitive region (see Fig. 7). Guidelines for sampling the various material types are presented in 10.2 and 10.3.

NOTE 13—Manufacturers supply a variety of holders for supporting IREs and samples. Designs vary and holders are not universally interchangeable among IRAs of different manufacturers. It is possible to obtain custom-made holders of preferred designs. Information concerning these is best obtained from manufacturers of IRS equipment.

10.2 Self-Adhering Materials:

10.2.1 With tacky solids, viscous semisolids, or pastes, good physical or optical contact is readily obtained by placing the desired sample area against the IRE.

10.2.2 Dissolve soluble nontacky solids in a suitable solvent. Control the thickness of the sample partly by adjusting the concentration of the solids in the solution. Then draw the solution into a capillary tube and apply it to an IRE so that the tip of the capillary does not touch it. Hold the IRE by the sides in a tilted position, so that the solution flows down and spreads out. The area covered by the sample can be controlled to a certain extent by a manual tilting motion of the IRE. Permit the sample to dry until the solvent bands disappear. If the spectrum is too intense, remove the excess sample by saturating a soft rayon ball with the solvent used, then carefully wipe off the sample at the edges until the sample produces the desired spectral contrast.

10.3 Nonadhering Samples:

10.3.1 *Solid Sample Holder*—Use a solid sample holder to support nonadhering samples. To obtain uniform contact between the sample and the IRE, apply pressure by adjusting the pressure plate. Apply pressure reproducibly by using a torque wrench. This is particularly important when an attempt is made to obtain spectra of reproducible contrast. If the pressure is not uniformly distributed across the IRE surface, brittle IREs will crack and soft IREs will be deformed. Distribute the pressure by lining the metal pressure plate with a relatively soft neoprene-backed or TFE-fluorocarbon (heavy gage) backed pressure-sensitive adhesive tape. If the entire area of the lined pressure plate is not completely covered with sample, there is a possibility of the lining material making contact with the IRE surface. This could lead to erroneous interpretation of the sample spectrum. To eliminate possible mistakes of this type, the dimensions of the lining material should not exceed those of the sample.

10.3.2 *Films*—Cut the sample to size, place into a solid-sample holder with the identical side of film of the same dimensions and in the same position on both sides of the IRE. Apply uniform pressure in accordance with the manufacturer's instructions. The manner and ease of obtaining uniform pressure depends on the specific design of the holder.

10.3.3 *Fibers*—Sample long, single filaments or yarns by winding a band about 20 mm wide around both sides of the solid-sample holder. Strands should be close together, but not crossing each other, so that an even sample area is produced. With careful sampling, sufficient uniform pressure can be applied without deforming soft IREs. However, there is a danger of deforming the IRE, leaving an imprint of individual strands on the surface, if too much pressure is applied. An alternative approach is to lay the strands onto the adhesive

surface of a length of tape. The tacky adhesive holds each strand in place while the next is being applied. In this way, the entire surface of adhesive is uniformly covered with aligned filaments or yarns. Two identical samples may be cut to the size of the IRE and placed in the sample holder on both sides of the IRE. Sufficient uniform pressure is easily applied with no risk of deforming or fracturing the IRE.

10.3.4 *Powders*—Powders may be sampled in several ways. Soluble powders may be deposited from solution directly onto the IRE using a capillary tube. Evaporate the solvent, thereby leaving the sample. Sufficient contact may not be obtained using this method. If it is not, press the powder against the IRE in a solid sample holder. Care should be taken if the particles are hard, since the IRE may be scratched or deformed when pressure is applied. Another approach is to spread the powder uniformly across the sticky side of an adhesive tape, then sample in the same manner as for films. Insoluble powders may be suspended in a solvent, then deposited onto an IRE as a slurry. A powdered film remains on the IRE after solvent evaporation. Special double-pass plates or prism IREs can be dipped into the powder. If sufficient contact is obtained using this approach, immersion depth controls spectral intensity. (13)

10.3.5 *Pliable Insoluble Solids*—High-molecular weight polymers, papers, fabrics, and foams may all fall into this category. Cut or slice an appropriate sample to size so that the surface is reasonably smooth before sampling in the same manner as for films.

10.3.6 *Hard Brittle Materials*—These types are among the most difficult to sample in their natural state. If the surface is smooth, cleave the sample to size with a sharp razor blade. If not, even the surface by careful abrading. Pulverize brittle samples and sample as powders. If the sample is completely intractable, pyrolysis may provide the only means for identifying organic components from condensable pyrolyzate fractions by transmission or IRS data.⁷

10.3.7 *Liquids*—Sealed cylindrical internal reflection cells, sealable and demountable prism liquid cells, platform cavity cells, and special double-pass plates,⁸ mounted in a vertical position, are available for liquid sampling. In fixed volume types, fill the cell or cavity volume using a syringe. When using prism liquid cells, adjust the liquid height in the cell chamber so that the IRE immersion depth provides optimum spectral intensity for the material type. Using the vertical-mounted IREs, dip the IRE into a beaker of the liquid sample. Control the spectral intensity by adjusting the immersion depth of the IRE in the liquid. Take care in selecting the IRE material in order to avoid corrosion. (Whenever the liquid contains multiple components, surface potentials can contribute to a segregation of components near the IRE surface. The spectrum recorded in this case may not be a true representation of the mixture.)

⁷ Pyrolysis IRS equipment is available from Spectra Tech, Inc., Stamford, CT; Harrick Scientific Corp., Ossining, NY; and R.J. Harvey Instrument Corp., Hillsdale, NY.

⁸ Necessary optical components for utilization of vertical double-pass IREs are commercially available from Harrick Scientific Corp., Ossining, NY, and from Wilks Infrared Center, Foxboro Corp., Plymouth, MA.

11. Record of Experimental Conditions

11.1 Label the IRS spectrum with the following information:

- 11.1.1 Sample identification, special treatment, size, position on IRE, and sampling conditions,
- 11.1.2 IRE material, θ , N , or l/t ,
- 11.1.3 IRA manufacturer and model number, and
- 11.1.4 Infrared spectrophotometer manufacturer, model No., and instrumental conditions.

12. Interpretation of Data

12.1 It should be remembered that, in internal reflection spectra of bulk materials, only a thin layer of film near the surface is sampled. The spectrum depends principally upon the composition of the part of the sample that is in contact with the IRE surface. This may be different from the bulk of the sample in thin-layer laminates or in materials exhibiting orientation effects or exudation of some components. Band intensities, shapes, and locations depend on the angle of incidence and relative refractive index, n_{21} , and therefore caution is advisable when comparing spectra with those obtained by transmission methods.

12.2 The penetration depth in IRS is proportional to the wavelength (Eq 3). Therefore, absorption bands at longer wavelengths appear relatively stronger than those at shorter wavelengths. This variation in penetration depth may cause bands at 3 μm to show only one fifth the absorption intensity expected from the transmission spectra, relative to bands at 15 μm . The IRS spectra of very thin films more closely resemble those obtained by transmission than do the IRS spectra of thicker specimens. The effective thickness of films up to 100 nm is proportional to the actual thickness. When all of the variables are understood and controlled, IRS spectra can be obtained in which the band shapes and positions are sufficiently similar to those of transmission spectra that available libraries of spectra may be consulted for identification. For identification by direct comparison, it is preferable that IRS spectra of standards be consulted.

13. Applications

13.1 Practically all samples adaptable to transmission techniques can also be studied by reflectance methods. The choice of which method is better for a particular sample depends on a combination of considerations: specific spectral information desired, physical form of sample, opacity of sample, available reference spectra, amount of sample, ease of sampling, or analysis time.

13.1.1 The IRS can be employed when a sample cannot be conveniently studied by transmission techniques. For opaque or intractable samples, reflectance methods might provide the only means for obtaining a spectrum. The IRS is the preferred technique when a knowledge of an untampered functional layer or a nondestructive method is desired. Useful spectra of coatings, adhesive rubber and rubberlike materials, laminates (14) (see Fig. 10), textiles, fibers, paper, soft thick films, geological samples, aqueous solutions, and very small residues can easily be obtained by IRS. In some cases, a combination of both transmission and reflection methods can provide a more accurate characterization of the composition of bulk materials

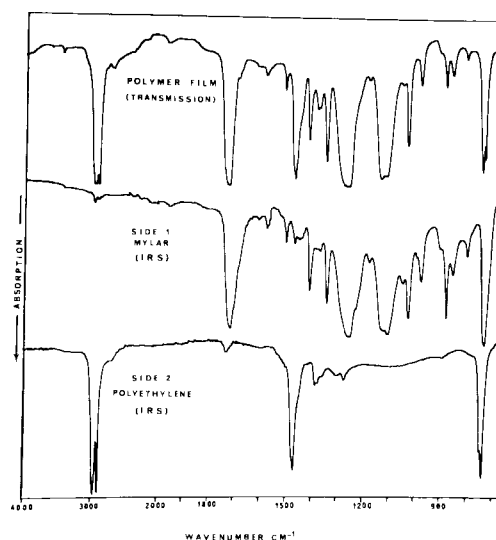

NOTE 1—The top spectrum might be misinterpreted as a copolymer. IRS spectra of Side 1 and Side 2 clearly indicate the composition of the laminate (14).

FIG. 10 IRS and Transmission Spectra of a Mylar-Polyethylene Laminate

than is possible by use of either method alone.

13.1.2 Some applications that are more conveniently handled by IRS methods are noted in this section. Suggested experimental conditions that provide good quality spectra are presented and are intended to serve as guidelines for sampling, and do not necessarily indicate conditions for optimum spectral contrast. Although optimum sampling conditions are preferable, it is possible to obtain useful spectra by using the best available compromise of IRS equipment, provided that θ remains above the critical angle, and that the experimental conditions are reproducible.

13.2 *Biological Samples: Skin, Bone, and Collagen from Connective Tissue (15)*—Cut thin slices of these samples with a razor or microtome. Mount on a 45° KRS-5, IRE in an appropriate sample holder. The IRS spectra of these materials

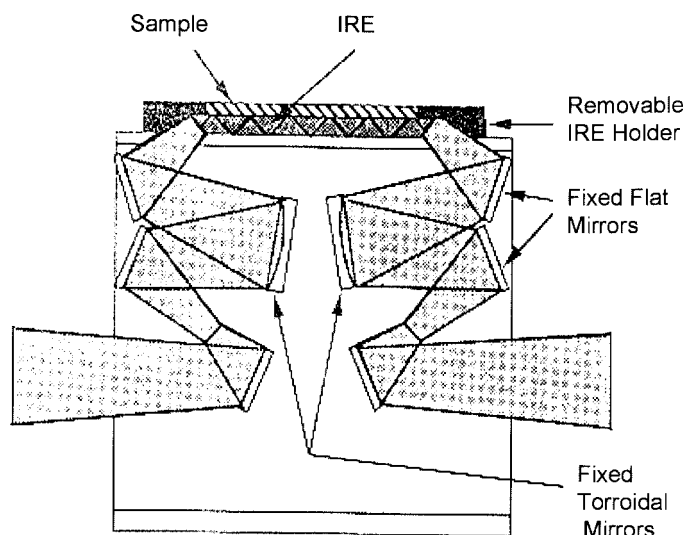

FIG. 11 Typical Beampath Followed in Horizontal IRA (29)

provide the advantage of in situ sampling, avoiding the possibility of denaturing the samples, and also providing identification of mineral components without the spurious side effects encountered during the sample preparation that is required for transmission spectra.

13.3 Cellulose Derivatives and Chemically Modified Cottons (16)—Obtain reflection spectra of these samples by sandwiching a 1 by 20 by 50-mm, 45°, KRS-5, IRE between two fabric samples that are cut to identical dimensions (but slightly smaller than the IRE), and then mounting in a lined solid sample holder. Apply uniform pressure with a torque wrench. With unmodified cellulose for comparison, the differences in chemical treatment can be observed and sometimes identified. Inspection of both sides of fabric can reveal preferential treatment of one side. Sateen fabric, woven with mercerized filling threads and unmercerized warp threads, indicates a face spectrum (Side 1) characteristic of mercerized cellulose and a back spectrum (Side 2) of unmodified cellulose. This information cannot be obtained using transmission methods.

13.4 Aqueous Solutions (17)—The IRS is useful in this case since transmission measurements may not be possible if inorganic or polar-organic material is only slightly soluble in the common infrared solvents. Using a liquid-sample holder, IRS spectra of aqueous solutions of carboxylic acids and alkali salts of carboxylic acids, sulfonic acids, glycine, amine salts, amino acids, amides, phenols, carbohydrates, and inorganic salts such as potassium hydrogen carbonate, potassium carbonate, sodium sulfate, potassium sulfite, sodium nitrate, sodium phosphate, and so forth, can be obtained. Good quality spectra of inorganic salts in water are obtained using a single-reflection IRE of Irtran-2, $\theta = 40^\circ$, $N = 1$.

13.5 Minerals—Qualitative spectra of minerals are obtained by grinding the sample to a powder of mixed-particle size, then sampling it as a powder. Provided θ is maintained above the critical angle, no scattering is observed in non-absorbing regions of the spectrum, offering an advantage over transmission, where useful spectra cannot be obtained with large-diameter particles. Spectral contrast of minerals using IRS is somewhat dependent on particle size, smaller particles giving higher spectral contrast. In spite of this, good quality spectra (18) of albite and augite have been obtained using mixed particles up to 100 μm in diameter. Experimental conditions that render good quality spectra are:

Mineral	IRE	θ , °	N
quartz	Ge	45	100
albite, augite	KRS-5	45	20

NOTE 14—Quartz has a refractive index from 0 to above 7 over one absorption band, so that the critical angle will move from zero to well above the angle of incidence regardless of the refractive index of IRE material. Very large absorptivities occur, and these, combined with refractive index variations, make the reflection metallic in certain spectral regions (18). In spite of this, internal reflection spectra can be obtained for quartz particle diameters up to 150 μm . Band shapes and locations depend on particle size and the degree of polarization of the radiation beam.

13.6 Polymers Stability—Reactions occurring at polymer surfaces are conveniently studied by IRS (19). Polyethylene, polypropylene, polycarbonate, poly(vinyl chloride), ABS, and other polymers may be artificially aged using ultraviolet light

or heat. Since some aging effects are initially concentrated on polymer surface, reflection spectra provide a means for early detection of surface reactions. Oxidative stability may be studied by monitoring the intensity of carbonyl absorption at 1709 cm^{-1} (5.85 μm). The ratio of carbonyl to methylene absorption at 1449 cm^{-1} (6.9 μm) can be used to estimate the relative extent of the oxidation. This ratio may then be related to some physical property such as tensile strength or brittleness. For these studies, mold the polymer to a uniform thickness with flat surfaces, or sample the film as is. After an appropriate aging cycle, cut samples to cover an IRE face entirely, then place them into a lined solid-sample holder, sandwiching a 2 by 20 by 50-mm, 45° KRS-5, IRE between them. Apply uniform pressure using a torque wrench.

13.7 Residues on Pressure-Sensitive Adhesive Tape Surface (8)—The performance of a pressure-sensitive adhesive can be adversely affected by the presence of very small amounts of surface contaminants. Frequently only a few monolayers of contaminant are involved. The IRS furnishes a means for obtaining a spectrum of the surface in question without altering the layer of interest. Detection of a contaminant can generally be accomplished by completely covering both faces of a 1 by 20 by 50-mm, 45°, KRS-5 IRE with sample. If the contaminant is sufficiently thick, a spectrum of the contaminant will result. If not, as is usually the case: (1) Using a double-beam dispersive system, a compensation spectrum can be run, placing a control sample free of contamination on the reference IRE. The area of the reference sample is adjusted until absorptions of the adhesive are cancelled, leaving a spectrum of the contaminant. Identification of a mixture of zinc salts of fatty acids (20) can be made in this manner. (2) Using a computerized (dispersive or FT-IR system), the control spectrum subtracted from that of the contaminated adhesive pattern generates a difference spectrum of the contaminant. For extremely thin surface residues, the tape may be applied to the IRE with slight pressure, then slowly peeled away at a 180° angle. This procedure will generally deposit the contaminant onto the IRE. The thickness of the residue can be built up by successive reapplications until the desired spectral contrast is obtained.

13.8 Pyrolyzates—Intractable samples such as highly filled and tightly cured resistor coatings, carbon black-filled tire stock and crosslinked, insoluble elastomers are difficult to sample by conventional transmission or reflectance techniques. This type of sample may be thermally decomposed using pyrolysis IRS. During pyrolysis, volatile and condensable phases are generally formed. Condensable degradation products most often include smaller polymer segments formed by means of a chain scission. This material is collected onto the optical face of a multiple-reflection IRE (usually KRS-5) supported by the pyrolysis chamber.

13.9 Other IRS Applications—Many other IRS applications are reported in the literature, and include: determination of optical constants (21) and coating thicknesses (4); molecular orientation studies (21) using polarized internal reflection measurements, such as molecular orientation of polypropylene (23) during uniaxial drawing; spectroscopic studies of electrochemical reactions using germanium (24) and other special

IRE-electrodes (25,26); and recording spectra of monomolecular films and powdered samples (27). For a more complete coverage of the subject, consult the literature and manufacturer's bulletins which include a variety of suggested applications.

14. Quantitative Aspects

14.1 *Reproducibility of Spectra*—Measurements of carefully designed IRS spectra yield Beer's law plots of absorbance versus concentration which can be used for quantitative analysis. For the quantitation of IRS data, it is essential that the infrared scans be reproducible. Experimental parameters must be rigidly controlled, and can be, if the following guidelines are used:

14.1.1 Select only the best quality IREs for quantitative analysis.

14.1.2 Maintain a reasonably constant IRE baseline (geometry and optical condition) throughout the analysis of standards and samples. It is important that the energy transmitted by the IRE be sufficiently high that low-energy spectra do not result. If spectra are completely reproducible, quantitative information may be derived even from spectra recorded under low-energy conditions. However, such spectra are frequently distorted and difficult to reproduce when using another IRE having the same geometry and composition and low-energy transmission.

14.1.3 Reproduce area and quality of contact of the sample IRE throughout the analysis. Uniform, reproducible contact is easily obtained with self-adhering and smooth, flat samples, but may be difficult with hard, and impossible with rough, surfaces. When less than the total IRE surface is used, samples should be mounted on the plate so that the identical region of the IRE is covered. It is not essential to know N , but only to reproduce N .

14.1.4 Maintain a balanced optical system of the transfer optics.

14.1.5 Where thin films are studied, maintain a constant film thickness or determine the exact film thickness.

14.1.6 When bulk samples are studied, the relationship of the analysis surface to the overall sample composition must be known. For some types of samples, such as coated films, plasticized films, or adhesive tapes, the surface will not be representative of bulk composition. In these cases, the surface composition may be related to that of the coating or the adhesive or to some prior treatment of the sample. If standards cannot be prepared and conditioned in the same manner as the sample, IRS should not be used for quantitative analysis.

14.2 *Special Applications*—There are some samples for which IRS spectra may have advantages over transmission spectra for quantitative work. For example, if films over 5 μm thick are used for obtaining IRS data, interference fringes can be avoided. Multiple reflections or large surface areas, or both, can enhance weak absorption bands to provide high sensitivity.

14.2.1 Levels of aromatic components in modified alkyds and alkyd resins and levels of unsaturation, for example, trans unsaturation at 970.9 cm^{-1} (10.3 μm) of petroleum resins, can be determined in IRS spectra, provided appropriate standards are available.

NOTE 15—For selecting analytical wavelength, absorption measurement, analytical curve preparation, and calculation methods, consult Practice E 168.

15. Keywords

15.1 internal reflection spectroscopy

APPENDIXES

(Nonmandatory Information)

X1. SYMBOLS RELATING TO INTERNAL REFLECTION SPECTROSCOPY¹²

A'	= aperture of IRE.	κ	= attenuation index.
a	= absorption parameter.	l	= length of IRE.
α	= absorption coefficient.	N	= number of reflections.
ATR	= attenuated total reflection.	n	= index of refraction.
d	= film thickness.	n_1	= index of refraction of IRE.
d_e	= effective pathlength, or effective thickness of a film.	n_2	= index of refraction of rarer medium or sample.
d_p	= penetration depth of electromagnetic field in rarer medium.	n_{21}	= refractive index ratio for reflecting interface, $n_{21} = n_2/n_1$.
δ	= phase shift of light due to reflection.	ν	= frequency of light.
P	= radiant power.	ϕ	= angle of refraction.
P_o	= radiant power of incident beam.	θ	= angle of incidence.
IRA	= internal reflection attachment.	θ_c	= critical angle.
IRE	= internal reflection element.	R	= reflectance, $R = r^2$.
IRS	= internal reflection spectroscopy.	r	= reflected amplitude for unit incident amplitude.
i	= square root of minus one.	t	= thickness of IRE.

X2. THEORY OF INTERNAL REFLECTION SPECTROSCOPY

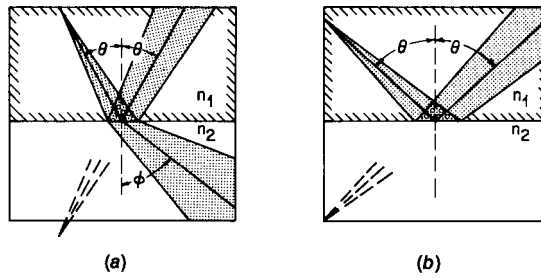

FIG. X2.1 Refraction and Internal Reflection of Rays of Light

X2.1 Nonabsorbing Media⁹

X2.1.1 Electromagnetic radiation that strikes an interface between two nonabsorbing media that have different refractive indexes, n_1 and n_2 , is partially transmitted and partially reflected. The angular relationship between the incident and refracted rays of the transmitted beam is given by Snell's law:

$$n_1 \sin \theta = n_2 \sin \phi \tag{X2.1}$$

in which θ and ϕ are the angles of incidence and refraction. For the reflected rays, the angle of reflection is equal to the angle of incidence (Fig. X2.1).

X2.1.2 For incident rays of unit amplitude, the amplitudes of reflected rays are given by Fresnel's equations:

$$r_{\perp} = -\frac{\sin(\theta - \phi)}{\sin(\theta + \phi)} \text{ and} \tag{X2.2}$$

$$r_{\parallel} = \frac{\tan(\theta - \phi)}{\tan(\theta + \phi)} \tag{X2.3}$$

Here, the electric field vector is perpendicular (\perp) to the plane of incidence for perpendicular polarization, and lies in the plane of incidence for parallel (\parallel) polarization.

X2.1.3 Reflectance, that is the fraction of the incident radiant power that is reflected, is equal to the square of the amplitude of the reflected ray. Near normal incidence, where $\phi \approx n_{12}\theta$ (n_{12} is the refraction index ratio, n_1/n_2), the reflectance is the same for both components of polarization, and is given as follows:

$$R = \frac{(n_{12} - 1)^2}{(n_{12} + 1)^2} \tag{X2.4}$$

X2.1.4 For external reflection, when the radiation strikes the interface from the medium of lower refractive index, the reflectances of the perpendicular and polarized rays vary with angle of incidence as shown by the solid curves of Fig. X2.2. The reflectance of the parallel-polarized component is zero at Brewster's angle (also called the polarizing angle):

$$\theta_B = \tan^{-1}(n_{12}) \tag{X2.5}$$

The reflectances for both polarizations are total (100 %) at grazing incidence ($\theta = 90^\circ$).

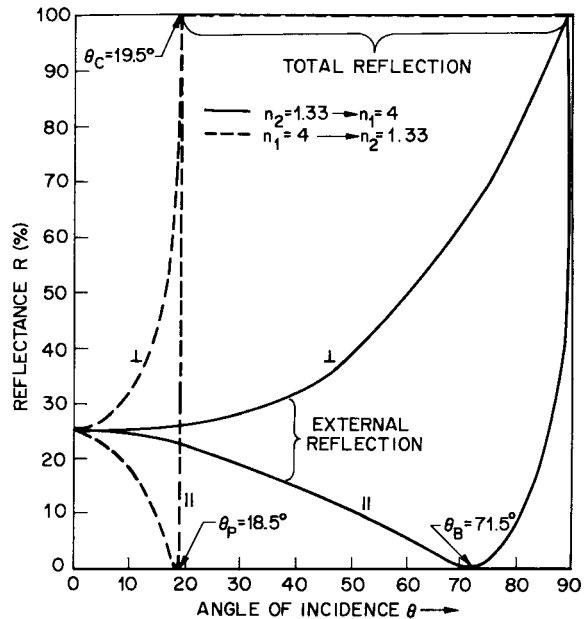

NOTE 1—Reflectance versus angle of incidence for an interface between media with indices, $n_1 = 4$ and $n_2 = 1.33$, for light polarized perpendicular, R_{\perp} , and parallel, R_{\parallel} , to plane of incidence for external reflection (solid lines) and internal reflection (dashed lines). θ_c , θ_B , and θ_p are the critical, Brewster's, and principal angles, respectively.

FIG. X2.2 Reflectance Versus Angle of Incidence

X2.1.5 For internal reflection, when the radiation strikes the interface from the medium of higher refractive index, the reflectances vary with angle of incidence as shown by the broken curves of Fig. X2.2. These are similar to the curves for external reflection, but extend over a smaller range of angles. The G reflectances for both polarizations are total at the critical angle, θ_c , as follows:

$$\theta_c = \sin^{-1} n_{21} \tag{X2.6}$$

X2.1.5.1 The reflectance of the parallel component is zero at an internal polarizing angle, θ_p , which is called the principal angle, and is the complement of Brewster's angle:

$$\theta_p = \tan^{-1} n_{21} \tag{X2.7}$$

X2.1.5.2 The reflectance of the parallel component increases abruptly over a very small range of the angle of incidence from θ_p to θ_c . This is accompanied by an abrupt change of the angle of refraction: ϕ becomes 90° for incidence

⁹ The Symbols provided in Appendix X1 are not to be considered standard nomenclature. These are under advisement by Subcommittee E13.04 on Nomenclature and must be further approved by ASTM Committee E-13 on Molecular Spectroscopy.

at θ_c , and is imaginary for $\theta > \theta_c$. The Fresnel reflection equations become:

$$r_{\perp} = \frac{\cos \theta - i(\sin^2 \theta - n_{21}^2)^{1/2}}{\cos \theta + i(\sin^2 \theta - n_{21}^2)^{1/2}} \quad (X2.8)$$

$$r_{\parallel} = \frac{n_{21}^2 \cos \theta - i(\sin^2 \theta - n_{21}^2)^{1/2}}{n_{21}^2 \cos \theta + i(\sin^2 \theta - n_{21}^2)^{1/2}} \quad (X2.9)$$

When n_{21} is real (both media nonabsorbing), $|r_{\perp}| = |r_{\parallel}| = 1$, and internal reflection is total for $\theta_c \leq \theta = 90^\circ$.

X2.2 Absorbing Rarer Medium

X2.2.1 When the rarer medium is absorbing, its complex refractive index

$$\hat{n}_2 = n_2(1 + i\kappa_2) \quad (X2.10)$$

replaces n_2 in the Fresnel Eq X2.8 and Eq X2.9 (Note X2.1). The attenuation index, κ , is related to the absorption coefficient, α , and the absorptivity, a , of the Bouguer-Beer law by:

$$n\kappa = \alpha c / 4\pi\nu \quad (X2.11)$$

$$P/P_o = e^{-ab} = 10^{-abc} \quad (X2.12)$$

$$\alpha = M \cdot a \cdot c \quad (X2.13)$$

Here, c_o is the velocity of light in vacuo, and ν its frequency. M is the natural logarithm of 10, $M = 2.303$; b is sample thickness, and c is the concentration of the absorbing species in the sample.

NOTE X2.1—The complex refractive index is written $n_2 = n_2 + i\kappa_2$ by IUPAC, and κ_2 is called the absorption index.

X2.2.2 Internal reflection is affected by an absorbing rarer medium as illustrated in Fig. X2.3. For radiation incident between $\theta = 0$ and $\theta \approx \theta_p$, internal reflectance is rather insensitive to absorption coefficient, until it becomes very large. For angles of incidence greater than the critical angle, however, internal reflectance can be highly sensitive to the absorption coefficient, and the parallel component of polarization is more sensitive than the perpendicular.

X2.3 Attenuated Total Reflection

X2.3.1 Maxwell's equations predict the evanescent wave that extends into the medium of lower refractive index, beyond the reflecting interface. The frequency of this wave is that of the incident radiation, and its amplitude diminishes exponentially with distance from the interface. It is possible to couple with this evanescent wave and extract energy from it, thereby making the reflection less than total. The strength of the coupling depends (in part) on the amplitude (electric field strength) of the evanescent wave. Frustrated total reflection occurs when the coupled medium does not absorb the energy, but conducts it away from the interface. Attenuated total reflection occurs when the coupled medium absorbs the energy extracted from the evanescent wave.

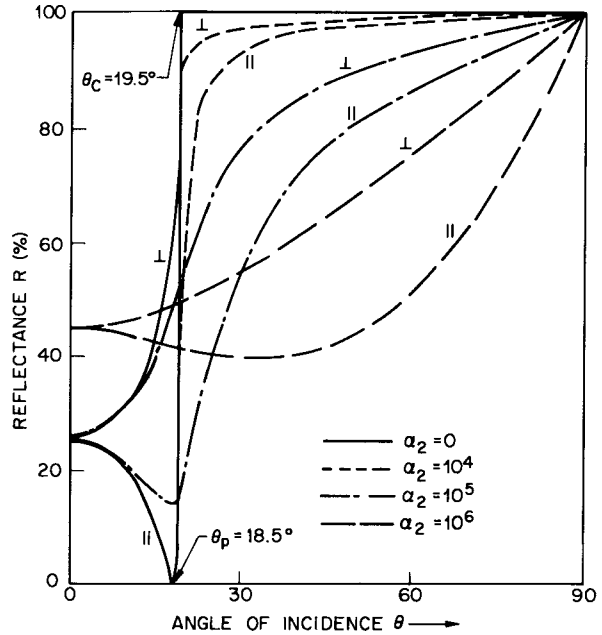

NOTE 1—Internal reflectance at an interface versus angle of incidence at $\lambda = 0.4 \mu\text{m}$ for $n_{21} = 0.333$ and various values of absorption coefficient α_2 . Note that the curves tend to resemble those for external reflection when α_2 becomes high.

FIG. X2.3 Internal Reflectance at an Interface Versus Angle of Incidence

X2.3.2 Attenuated total reflection is observed when the angle of incidence is maintained greater than the critical angle while wavelength is scanned across an absorption band. The amount by which internal reflection is diminished from being total, because of absorption of energy from the evanescent wave, that is, the reflectance loss per reflection, is the absorption parameter, a :

$$a = 1 - R \quad (X2.14)$$

The absorption parameter is greater near the critical angle than at larger angles, and is also greater for \parallel -polarization than for \perp -polarization.

X2.3.3 The relationship between attenuated internal reflectance and the absorption coefficient of Beer's law can be expressed in simplified form if absorption is small, for example, $\alpha b < 0.1$. Then Beer's law can be approximated by:

$$P/P_o \approx 1 - \alpha b \quad (X2.15)$$

where αb is the fraction absorbed for transmission through a sample of thickness, b . The corresponding quantity for internal reflection is the absorption parameter, so that the internal reflectance of a single reflection can be expressed by:

$$R = 1 - a = 1 - \alpha d_e \quad (X2.16)$$

Here d_e is an effective pathlength, or effective thickness of a thin film, and is defined by:

$$d_e = a/\alpha \quad (X2.17)$$

X3. INTERNAL REFLECTION ELEMENTS

X3.1 Various transparent optical elements used in internal reflection spectroscopy for establishing the condition necessary

to obtain the internal reflection spectra of materials are shown in Fig. X3.1.

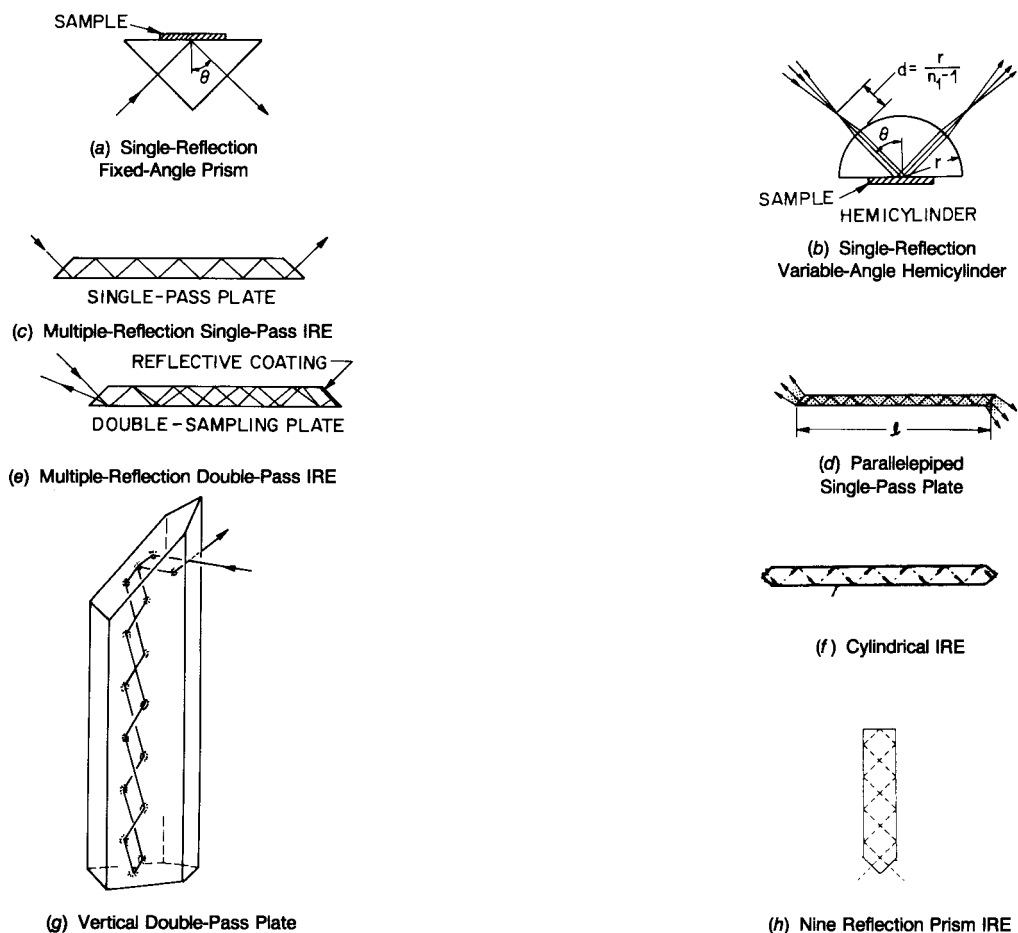

FIG. X3.1 Internal Reflection Elements

REFERENCES

- (1) Newton, *Opticks II*, Book 8, 1917 p. 97.
- (2) Fahrenfort, J., "Attenuated Total Reflectance—A New Principle for Production of Useful Spectra of Organic Compounds," *Molecular Spectroscopy*, 1962, p. 701.
- (3) Harrick, N. J., Discussion of December 1959, p. B.D.-4, following paper presented by Eischens, R. P., "Infrared Methods Applied to Surface Phenomena in Semiconductor Surfaces," (Proceedings of Second Conference), Pergamon Press, London, 1960, p. 56.
- (4) Mirabella, F. M., and Harrick, N. J., *Internal Reflection Spectroscopy Review and Supplement*, Harrick Scientific Corp., Ossining, NY, 1985.
- (5) Born, M., and Wolf, E., *Principles of Optics*, 2nd ed., Pergamon Press, NY, 1964.
- (6) Wilk's Scientific Corp., "Internal Reflection Spectroscopy," 1965, p. 1.
- (7) Gilby, A. C., Cassels, J., and Wilks, P. A., Jr., "Internal Reflection Spectroscopy III, Microsampling," *Applied Spectroscopy*, Vol 24, No. 5, 1970.
- (8) Paralusz, C. M., "Internal Reflection Spectroscopy Applied to the Analysis of Adhesive Tapes," *Journal of Colloid and Interface Science*, Vol 47, No. 3, 1974, pp. 719-746.
- (9) Wolfe, W. L., Ballard, S. S., and McCarthy, K. A., "Refractive Index of Special Crystals and Certain Glasses," *American Institute of Physics Handbook*, 2nd ed., Edited by E. E. Gray, McGraw Hill, New York, NY, 1963, p. 11.
- (10) McCarthy, K. G., Ballard, S. S., and Wolfe, W. L., "Transmission and Absorption of Special Crystals and Certain Glasses," *American Institute of Physics Handbook*, 2nd ed., Edited by E. E. Gray, McGraw Hill, New York, NY, 1963, p. 45.
- (11) Gilby, A. C., Burr, J., Jr., and Crawford, B., Jr., "Vibrational Intensities XII, An Optical-Mechanical System from Infrared Attenuated Total Reflection Measurements," *Journal of Physical Chemistry*, Vol 70, 1966, p. 1520.
- (12) Fahrenfort, J., and Visser, W. M., "On the Determination of Optical Constants in the Infrared by Attenuated Total Reflectance," *Spectrochimica Acta*, Vol 21, 1965, p. 1433.
- (13) Harrick, N. J., "The Internal Reflection Probe," *Analytical Chemistry*, Vol 43, No. 11, 1971, pp. 1533-1535.
- (14) Luongo, J. P., "Characterization of Polymeric Films by Reflection

- Spectroscopy," *Paper No. 2,137*, National Meeting of the Electrochemical Society in Los Angeles, CA, 1970.
- (15) Furedi, H., and Walton, A. G., "Transmission and Attenuated Total Reflection Spectra of Bone and Collagen," *Applied Spectroscopy*, Vol 22, No. 1, 1968, pp. 23–26.
 - (16) McCall, E. R., Miles, S. H., and O'Connor, R. T., "Frustrated Multiple Internal Reflectance Spectroscopy of Chemically Modified Cottons," *American Dyestuff Reporter*, Vol 55, No. 11, 1966, pp. 31–35.
 - (17) Katlatsky, B., and Keller, R. E., "ATR Infrared Analysis of Aqueous Solutions," *Analytical Chemistry*, Vol 35, 1963, p. 1665.
 - (18) Harrick, *Internal Reflection Spectroscopy*, pp. 233–239.
 - (19) Chan, M. G., and Hawkins, W. L., "Internal Reflection Spectroscopy in the Prediction of Outdoor Weatherability," *Polymer*, Vol 2, 1968, p. 1638.
 - (20) Medeck, E., "Some Qualitative and Quantitative Applications of Multiple Internal Reflection Spectroscopy," *Canadian Spectroscopy*, Vol 13, 1968, pp. 76–80.
 - (21) Hansen, W. N., "Internal Reflection Spectroscopy and the Determination of Optical Constants," *ISA Transactions*, Vol 4, 1965, p. 263.
 - (22) Flournoy, P. A., and Schaffers, W. J., "Attenuated Total Reflection Spectra from Surfaces of Anisotropic Absorbing Films," *Spectrochimica Acta*, Vol 22, 1966, p. 5.
 - (23) Flournoy, P. A., "Attenuated Total Reflection Spectra from Oriented Polypropylene Films," *Spectrochimica Acta*, Vol 22, 1966, p. 15.
 - (24) Mark, H. B., and Pons, B. S., *Analytical Chemistry*, Vol 38, 1966, p. 119.
 - (25) Hansen, W. N., "Spectroscopic Observation of an Electrochemical Reaction via Internal Reflection," *Modern Aspects of Reflectance Spectroscopy*, Edited by W. Wendlandt, Plenum Publishing Corp., New York, NY, 1968, pp. 182–191.
 - (26) Prostak, A., Mark, H. B., Jr., and Hansen, W. N., "Simultaneous Electrochemical and Internal Reflection Spectrometric Measurements Using Gold-Film Electrodes," *Journal of Physical Chemistry*, Vol 72, 1968, p. 2576.
 - (27) Harrick, N. J., "Enhanced Sensitivity for Internal Reflection Spectroscopy," *Modern Aspects of Reflectance Spectroscopy*, Edited by W. Wendlandt, Plenum Publishing Corp., New York, NY, 1968, pp. 207–215.
 - (28) Wilks, P. A., "Internal Reflection Spectroscopy I, Effect of Angle of Incidence Change," *Applied Spectroscopy*, Vol 22, No. 6, 1968, pp. 782–784.
 - (29) Compton, Senya V., and Compton, David A., "Optimization of Data Recorded by Internal Reflectance Spectroscopy," *Practical Sampling Techniques for Infrared Analysis*, P. B. Coleman, ed., CRC Press, 1993.

The American Society for Testing and Materials takes no position respecting the validity of any patent rights asserted in connection with any item mentioned in this standard. Users of this standard are expressly advised that determination of the validity of any such patent rights, and the risk of infringement of such rights, are entirely their own responsibility.

This standard is subject to revision at any time by the responsible technical committee and must be reviewed every five years and if not revised, either reapproved or withdrawn. Your comments are invited either for revision of this standard or for additional standards and should be addressed to ASTM Headquarters. Your comments will receive careful consideration at a meeting of the responsible technical committee, which you may attend. If you feel that your comments have not received a fair hearing you should make your views known to the ASTM Committee on Standards, at the address shown below.

This standard is copyrighted by ASTM, 100 Barr Harbor Drive, PO Box C700, West Conshohocken, PA 19428-2959, United States. Individual reprints (single or multiple copies) of this standard may be obtained by contacting ASTM at the above address or at 610-832-9585 (phone), 610-832-9555 (fax), or service@astm.org (e-mail); or through the ASTM website (www.astm.org).