



Designation: C 11 – 01a

## Standard Terminology Relating to Gypsum and Related Building Materials and Systems<sup>1</sup>

This standard is issued under the fixed designation C 11; the number immediately following the designation indicates the year of original adoption or, in the case of revision, the year of last revision. A number in parentheses indicates the year of last reapproval. A superscript epsilon ( $\epsilon$ ) indicates an editorial change since the last revision or reapproval.

### 1. Scope

1.1 This standard contains terminology relating to gypsum and related building materials and systems. The terms are generically defined. More specific and expanded definitions may appear in appropriate standards.

### 2. Referenced Documents

#### 2.1 ASTM Standards:

- C 22/C 22M Standard Specification for Gypsum<sup>2</sup>
- C 28 Specification for Gypsum Plasters<sup>2</sup>
- C 35 Specification for Inorganic Aggregates for Use in Gypsum Plaster<sup>2</sup>
- C 36 Specification for Gypsum Wallboard<sup>2</sup>
- C 37 Specification for Gypsum Lath<sup>2</sup>
- C 52 Specification for Gypsum Partition Tile or Block<sup>3</sup>
- C 59 Specification for Gypsum Casting and Molding Plaster<sup>2</sup>
- C 61 Specification for Gypsum Keene's Cement<sup>2</sup>
- C 79 Specification for Gypsum Sheathing Board<sup>2</sup>
- C 317 Specification for Gypsum Concrete<sup>2</sup>
- C 318 Specification for Gypsum Formboard<sup>3</sup>
- C 472 Test Methods for Physical Testing of Gypsum, Gypsum Plasters and Gypsum Concrete<sup>2</sup>
- C 473 Test Methods for Physical Testing of Gypsum Board Products and Gypsum Lath<sup>2</sup>
- C 475 Specification for Joint Compound and Joint Tape for Finishing Gypsum Board<sup>2</sup>
- C 557 Specification for Adhesives for Fastening Gypsum Wallboard to Wood Framing<sup>2</sup>
- C 587 Specification for Gypsum Veneer Plaster<sup>2</sup>
- C 588 Specification for Gypsum Base for Veneer Plasters<sup>2</sup>
- E 84 Test Method for Surface Burning Characteristics of Building Materials<sup>4</sup>
- E 96 Test Methods for Water Vapor Transmission of Materials<sup>5</sup>

E 119 Test Methods for Fire Tests of Building Construction and Materials<sup>4</sup>

E 337 Test Method for Measuring Humidity With a Psychrometer (The Measurement of Wet- and Dry-Bulb Temperatures)<sup>6</sup>

### 3. Terminology

**accelerator**, *n*—a material that will shorten the setting time of gypsum plasters.

**accessories**, *n*—products fabricated for the purpose of forming corners, edges, control joints, or decorative effects.

**adhesive**, *n*—a substance capable of holding materials together by surface attachment.

**admixture**, *n*—a material other than water, aggregate, or inorganic cementitious material that is used as an ingredient in gypsum plaster or cement plaster and is added to the batch immediately before or during job mixing.

**aggregate**, *n*—an inert granular material which may be added to gypsum plasters. (C 35)

**all purpose compound**, *n*—a compound formulated and manufactured to serve as a taping or finishing compound, or both.

**anhydrite**, *n*—the mineral consisting primarily of anhydrous calcium sulfate,  $\text{CaSO}_4$ .

**arris (of an arch)**, *n*—the outside corner or angle formed by the meeting of a wall surface with the curved surface of an arch (see Fig. 1).

**base coat**, *n*—the first layer or layers of plaster applied over a lath or other substrate. The first application is normally called a scratch coat and the second application is referred to as a brown coat.

**base coat floating**, *n*—the finishing act of spreading, compacting, and smoothing of the base coat plaster to a reasonably true plane.

**bedding coat**, *n*—that coat of plaster to receive aggregate or other decorative material of any size, impinged or embedded into its surface, before it sets.

**bond plaster**, *n*—a calcined gypsum plaster specially formulated for application over rough monolithic concrete as a bonding coat for a subsequent gypsum plaster layer. (C 28)

**bridging**, *n*—*in framing*, sections of wood or metal pieces

<sup>1</sup> This terminology is under the jurisdiction of ASTM Committee C11 on Gypsum and Related Building Materials and Systems and are the direct responsibility of Subcommittee C11.91 on Terminology and Editorial.

Current edition approved Dec. 10, 2001. Published February 2002. Originally published as C 11 – 16 T. Last previous edition C 11 – 01.

<sup>2</sup> Annual Book of ASTM Standards, Vol 04.01.

<sup>3</sup> Discontinued: See 1982 Annual Book of ASTM Standards, Vol 04.01.

<sup>4</sup> Annual Book of ASTM Standards, Vol 04.07.

<sup>5</sup> Annual Book of ASTM Standards, Vol 04.06.

<sup>6</sup> Annual Book of ASTM Standards, Vol 11.03.

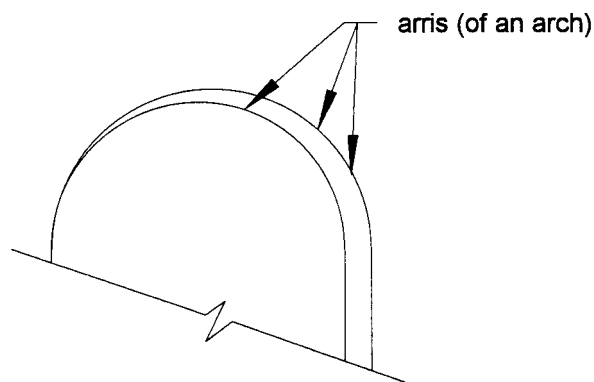

FIG. 1 Arris (of an Arch)

used between framing members to stiffen, give lateral support, and minimize rotation.

**brown coat**, *n*—the second coat in three-coat gypsum plaster application.

**building construction joint**, *n*—a designed division of a building that allows movement of all component parts of the building, in any plane, which may be caused by thermal, seismic, wind loading or any other force. The construction of the separation is accomplished by one of the following methods: (1) manufactured devices suitable for this application, or (2) by field fabrication of suitable materials.

**calcined gypsum**, *n*—a dry powder; primarily calcium sulfate hemihydrate, resulting from calcination of gypsum; cementitious base for production of most gypsum plasters: also called plaster of paris; sometimes called stucco.

**calcium sulfate**, *n*—the chemical compound  $\text{CaSO}_4$ .

**cementitious material**, *n*—a material that, when mixed with water, with or without aggregate, provides the plasticity and the cohesive and adhesive properties necessary for placement, and the formation of a rigid mass.

**coat**, *n*—a layer of plaster applied in a single operation.

**combined water**, *n*—the water chemically held, as water of crystallization, by the calcium sulfate dihydrate or hemihydrate crystal.

**compressive strength**, *n*—the maximum load sustained by a standard specimen of a material when subjected to a crushing force.

**consistency**, *n*—a property of a material determined by the complete flow force relation. (C 557)

**consistency (normal)**, *n*—the number of millilitres of water per 100 g of gypsum plaster or gypsum concrete required to produce a mortar or a slurry of specified fluidity. (C 472)

**control (expansion-contraction) joint**, *n*—a designed separation in the system materials that allows for movement caused by expansion or contraction of the system. The construction of the separation is accomplished by one of the following methods: (1) manufactured devices suitable for this application, or (2) by field fabrication of suitable materials.

**core (of gypsum board)**, *n*—the hardened material filling the space between the face and back papers consisting substantially of rehydrated gypsum with additives.

**cored tile or block**, *n*—see **gypsum tile or block**. (C 52)

**corner reinforcement, exterior**, *n*—a preformed section of wire or expanded sheet steel, for the reinforcement of exterior stucco external corners (arries).

**cure (portland cement plaster or stucco)**, *v*—(1) to provide conditions conducive to the hydration process of portland cement plaster or stucco.

(2) to maintain proper temperature and a sufficient quantity of water within the plaster to ensure cement hydration.

**dash-bond coat**, *n*—a thick slurry of portland cement, sand, and water, machine-sprayed or hand-dashed with a paddle or stiff-bristled broom to any acceptable surface, to provide improved adhesion and a key for the subsequent portland cement plaster or stucco coat.

**density**, *n*—the weight per unit volume of a material. (C 472)

**edge (of gypsum board)**, *n*—the paper-bound edge as manufactured.

*embedding compound*—see **taping compound**.

**end (of gypsum board)**, *n*—the end perpendicular to the paper-bound edge. The gypsum core is always exposed.

*expansion joint*, *n*—see **control (expansion-contraction) joint**.

**face**, *n*—the surface designed to be left exposed to view or to receive decoration or additional finishes.

**featured edge**, *n*—an edge configuration of the paper bound edge of gypsum board that provides special design or performance.

**fineness modulus**, *n*—an empirical factor obtained by adding total percentages of a sample of aggregate retained on each of a specified series of sieves and dividing by 100. The sieve sizes used are: No. 100 (150  $\mu\text{m}$ ), No. 50 (300  $\mu\text{m}$ ), No. 30 (600  $\mu\text{m}$ ), No. 16 (1.18 mm), No. 8 (2.36 mm), No. 4 (4.75 mm),  $\frac{3}{8}$  in. (9.5 mm),  $\frac{3}{4}$  in. (19.0 mm), 1 $\frac{1}{2}$  in. (38.1 mm) and larger, increasing in the ratio of 2 to 1.

**finish coat**, *n*—the final layer of plaster applied over a basecoat or other substrate.

**finish coat floating**, *n*—the finishing act of spreading, compacting, and smoothing the finish coat plaster or stucco to a specified surface texture.

**finishing compound**, *n*—(sometimes called *topping compound*) a compound specifically formulated and manufactured for use over taping or all purpose compounds to provide a smooth and level surface for the application of decoration.

**fire-resistance classification**, *n*—a standard rating of fire-resistance and protective characteristics of a building construction or assembly. (E 119)

**flame spread classification**, *n*—a standard rating of relative surface burning characteristics of a building material as compared to a standard material. (E 84)

**flexural strength**, *n*—the maximum load sustained by a standard specimen of a sheet material when subjected to a bending force.

**framing member**, *n*—stud, plate, track, joist, furring, and other support to which a gypsum panel product, or metal plaster base is attached.

**free water**, *n*—all water contained by gypsum board or plaster in excess of that chemically held as water of crystallization.

**gauging plaster**, *n*—a calcined gypsum plaster designed to be mixed with lime putty. (C 28)

**grout**, *n*—gypsum or portland cement plaster used to fill

crevices or to fill hollow metal frames.

**gypsum**, *n*—the mineral consisting primarily of fully hydrated calcium sulfate,  $\text{CaSO}_4 \cdot 2\text{H}_2\text{O}$  or calcium sulfate dihydrate. (C 22/C 22M)

**gypsum backing board**, *n*—a ¼ in. to ⅝ in. gypsum board for use as a backing for gypsum wallboard, acoustical tile, or other dry cladding.  
*water resistant gypsum backing board*—a gypsum board designed for use on walls primarily as a base for the application of ceramic, or plastic tile.

**gypsum base for veneer plasters**, *n*—a gypsum board used as the base for application of a gypsum veneer plaster. (C 588)

**gypsum board**, *n*—the generic name for a family of sheet products consisting of a noncombustible core primarily of gypsum with paper surfacing.

**gypsum concrete**, *n*—a calcined gypsum mixed with wood chips or aggregate, or both. (C 317)

**gypsum core board**, *n*—a ¾ in. (19.0 mm) to 1 in. (25.4 mm) gypsum board consisting of a single board or factory laminated multiple boards, used as a gypsum stud or core in semisolid or solid gypsum board partitions.

**gypsum formboard**<sup>7</sup>, *n*—a gypsum panel product used as the permanent form for poured gypsum roof decks. (C 318)

**gypsum lath**, *n*—a gypsum board used as the base for application of gypsum plaster. (C 37)  
*perforated gypsum lath*<sup>7</sup>—a gypsum lath having perforations to provide mechanical keying of the basecoat plaster.  
*foil-backed gypsum lath*—the same as plain gypsum lath except that in addition, the back surface shall be covered with a continuous sheet of pure bright finished aluminum foil.  
*type X lath*—a gypsum lath specially manufactured to provide specific fire-resistant characteristics.

**gypsum molding plaster**, *n*—a calcined gypsum plaster used primarily for plaster casts or molds, sometimes used as a gauging plaster. (C 59, C 28)

**gypsum neat plaster**, *n*—a calcined gypsum plaster without aggregate; common usage is for gypsum plaster used for base coats. (C 28)

**gypsum panel products**, *n*—the general name for a family of sheet products consisting essentially of gypsum.

**gypsum plaster**, *n*—the generic name for a family of powdered cementitious products consisting primarily of calcined gypsum with additives to modify physical characteristics, and having the ability, when mixed with water, to produce a plastic mortar or slurry which can be formed to the desired shape by various methods and will subsequently set to a hard, rigid mass. (C 28)

**gypsum sheathing**, *n*—a gypsum board used as a backing for exterior surface materials, manufactured with water-repellant paper and may be manufactured with a water-resistant core. (C 79)

**gypsum tile or block**<sup>7</sup>, *n*—a cast gypsum building unit. (C 52)

**gypsum wallboard**, *n*—a gypsum board used primarily as an interior surfacing for building structures. (C 36)  
*foil-backed gypsum wallboard*—a gypsum wallboard with the back surface covered with a continuous sheet of pure bright finished aluminum foil. (C 36)  
*type X gypsum wallboard*—a gypsum wallboard specially manufactured to provide specific fire-resistant characteristics (C 36).

**gypsum wood-fibered plaster**, *n*—a calcined gypsum plaster containing shredded or ground wood fiber added during manufacture.

**hemihydrate**, *n*—the dry powder, calcium sulfate hemihydrate, resulting from calcination of  $\text{CaSO}_4 \cdot 2\text{H}_2\text{O}$ , calcium sulfate dihydrate. See **calcined gypsum**.

**joining**, *n*—the juncture of two separate plaster applications of the same coat, usually within a single surface plane.

**joint compound**, *n*—a compound used for taping or finishing gypsum board, or both.

**joint reinforcing metal**, *n*—strips of expanded metal, woven or welded wire mesh used to reinforce corners and other areas of plaster and lath.

**joint tape**, *n*—a type of paper, metal, fabric, glass mesh, or other material, commonly used with a cementitious compound, to reinforce the joints between adjacent gypsum boards. (C 475)

**Keene's cement**, *n*—an anhydrous gypsum plaster characterized by a low mixing water requirement and special setting properties, primarily used with lime to produce hard, dense finish coats. (C 61)

**key**, *n*—the grip or mechanical bond of one coat of plaster to another coat, or to a plaster base. It may be accomplished physically by the penetration of wet mortar or crystals into paper fibers, perforations, scoring irregularities, or by the embedment of the lath.

*lath*—see **gypsum lath**.

**load-bearing partition**, *n*—a partition designed to support a portion of the building structure.

**machine direction**, *n*—the direction parallel to the paper-bound edge of the gypsum board.

**masonry cement**, *n*—a hydraulic cement for use in mortars for masonry construction, containing one or more of the following materials: portland cement, portland blast furnace slag cement, portland-pozzolan cement, natural cement, slag cement, or hydraulic lime; and in addition usually containing one or more materials such as hydrated lime, limestone, chalk, calcareous shell, talc, slag, or clay as prepared for this purpose.

**mechanical bonds**, *n*—the attachment created when plaster penetrates, into or through, the substrate, or envelops irregularities in the surface of the substrate.

**mill-mixed plaster (ready-mixed plaster)**, *n*—material formulated and dry-blended by the manufacturer, requiring only the addition of and mixing with water.

**mortar**, *n*—a mixture of gypsum plaster with aggregate or hydrate lime, or both, and water to produce a trowelable fluidity.

*neat gypsum plaster*—see **gypsum neat plaster**.

**perm**, *n*—a unit of measurement of water vapor permeance; a

<sup>7</sup> This product is no longer manufactured, and the specifications for it have been discontinued but the definition is retained for reference purposes.

metric perm, or 1 g/24 h·m<sup>2</sup>·mm Hg. U.S. unit, 1 grain/h·ft<sup>2</sup>·in. Hg. (E 96)

**permeability, *n***—the property of a porous material that permits a fluid (or gas) to pass through it; in construction, commonly refers to water vapor permeability of a sheet material or assembly and is defined as water vapor permeance per unit thickness. Metric unit of measurement, metric perms per centimetre of thickness. See **water vapor transmission, perm, permeance.** (E 96)

**permeance (water vapor), *n***—the ratio of the rate of water vapor transmission (WVT) through a material or assembly between its two parallel surfaces to the vapor pressure differential between the surfaces. Metric unit of measurement is the metric perm, 1 g/24 h·m<sup>2</sup>·mm Hg; U.S. unit, 1 grain/h·ft<sup>2</sup>·in. Hg. See **water vapor transmission, permeability, perm.** (E 96)

*plaster*—see **gypsum plaster, gypsum neat plaster.**

**plaster bond, *n***—the state of adherence between plaster coats or between plaster and a plaster base, produced by adhesive or mechanical interlock of plaster with base or special supplementary materials.

**plastic cement, *n***—a hydraulic cement to which one or more plasticizing agents (but not more than 12 % by volume) have been added during intergrinding or blending to increase the workability and molding qualities of the resultant cement paste, mortar, or plaster.

**plasticity, *n***—that property of freshly mixed cement paste, mortar, or plaster which determines its workability and molding qualities.

**portland cement, *n***—a hydraulic cement produced by pulverizing clinker consisting essentially of hydraulic calcium silicates, and usually containing one or more forms of calcium sulfate as an interground addition.

**portland cement plaster, *n***—a plaster mix in which portland cement or combinations of portland and masonry cements or portland cement and lime are the principal cementitious materials mixed with aggregate.

**purity, *n***—the percentage of CaSO<sub>4</sub>·½H<sub>2</sub>O in the calcined gypsum portion of a gypsum plaster or gypsum concrete, as defined by Specification C 28, for Gypsum Plasters. The percentage of CaSO<sub>4</sub>·2H<sub>2</sub>O in the gypsum or the gypsum portion of fully hydrated, dry, set gypsum plaster. (C 472, C 28)

**ready-mixed plaster, *n***—a calcined gypsum plaster with aggregate added during manufacture. (C 28)

**relative humidity, *n***—the ratio of actual water vapor pressure to the saturation water vapor pressure at the same temperature, expressed as a percentage. (E 337)

**retarder, *n***—a material that will lengthen the setting time of gypsum plaster.

**round edge, *n***—a rounded, paper-bound edge formation on gypsum board, commonly used for gypsum lath. (C 37, C 473)

**saddle-tie, for furring, *n***—a single or double strand of wire used to attach furring members to framing members of wall or ceiling assemblies. See Fig. 2.

**saddle-tie, for furring, *v***—to attach furring members to framing members of wall or ceiling assemblies using a single or

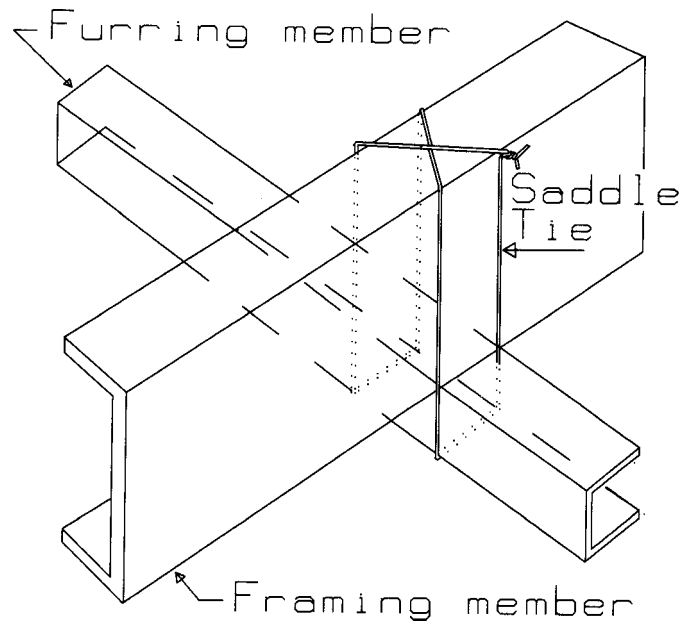

FIG. 2 Saddle-Tie

double strand of wire. See Fig. 2.

**saddle-tie, for wire hangers, *v***—to attach wire hangers to main runners. See Fig. 3.

**set, *n***—the hardening and hydration of a gypsum plaster. See **setting time.** (C 472)

**setting time, *n***—the elapsed time required for a gypsum plaster to attain a specified hardness and strength after mixing with water. (C 472)

**stucco, *n***—a portland cement-aggregate plaster mix designed for use on exterior surfaces. See **portland cement plaster.**

**synthetic gypsum, *n***—a chemical product, consisting primarily of calcium sulfate dihydrate (CaSO<sub>4</sub>·2H<sub>2</sub>O) resulting primarily from an industrial process.

**tapered edge, *n***—an edge formation of gypsum board which provides a shallow depression at the paper-bound edge to

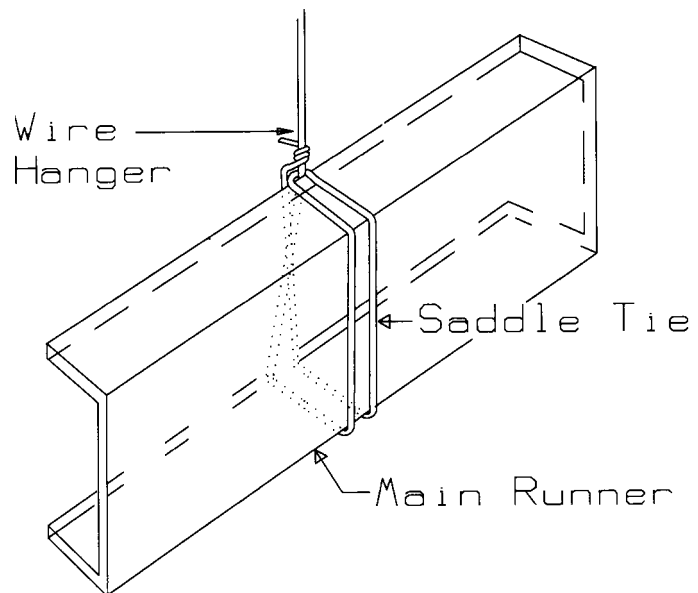

FIG. 3 Saddle-Tie

receive joint reinforcement. (C 473, C 36)

**taping compound**, *n*—(sometimes called *embedding compound*) a compound specifically formulated and manufactured for use in embedding of joint reinforcing tape at gypsum board joints.

**three-coat work**, *n*—plaster applied in three successive coats with time between coats for setting or drying, or both.

*topping compound*—see **finishing compound**.

**veneer plaster**, *n*—a calcined gypsum plaster specially manufactured to provide high strength, hardness, and abrasion resistance when applied in thin coats over a gypsum base for veneer plasters. (C 587)

*wallboard*—see **gypsum wallboard**. (C 36)

**water absorption**, *n*—the amount of water absorbed by a material under specified test conditions commonly expressed as weight percent of the test specimen.

**water-repellent paper**, *n*—gypsum board paper surfacing which has been formulated or treated to resist water penetration.

**water-resistant core**, *n*—a gypsum board specially formulated to resist water penetration.

**water vapor transmission (WVT)**, *n*—the rate of water vapor flow, under steady specified conditions, through a unit area of a material, between its two parallel surfaces and normal to the surfaces. Metric unit of measurement is  $1 \text{ g}/24 \text{ h}\cdot\text{m}^2$ . See **permeability, permeance, perm.** (E 96)

**wood-fibered plaster**, *n*—a calcined gypsum plaster containing shredded or ground wood fiber added during manufacture. (C 28)

*This standard is subject to revision at any time by the responsible technical committee and must be reviewed every five years and if not revised, either reapproved or withdrawn. Your comments are invited either for revision of this standard or for additional standards and should be addressed to ASTM International Headquarters. Your comments will receive careful consideration at a meeting of the responsible technical committee, which you may attend. If you feel that your comments have not received a fair hearing you should make your views known to the ASTM Committee on Standards, at the address shown below.*

*This standard is copyrighted by ASTM International, 100 Barr Harbor Drive, PO Box C700, West Conshohocken, PA 19428-2959, United States. Individual reprints (single or multiple copies) of this standard may be obtained by contacting ASTM at the above address or at 610-832-9585 (phone), 610-832-9555 (fax), or service@astm.org (e-mail); or through the ASTM website (www.astm.org).*