



Designation: C 473 – 003

Standard Test Methods for Physical Testing of Gypsum Panel Products¹

This standard is issued under the fixed designation C 473; the number immediately following the designation indicates the year of original adoption or, in the case of revision, the year of last revision. A number in parentheses indicates the year of last reapproval. A superscript epsilon (ϵ) indicates an editorial change since the last revision or reapproval.

1. Scope*

- 1.1 These test methods cover the physical testing of gypsum panel products.
- 1.2 The test methods appear in the following order:

Flexural Strength (Method A)	Section 7
Core, End and Edge Hardness (Method A)	8
Nail Pull Resistance (Method A)	9
Flexural Strength (Method B)	11
Core, End and Edge Hardness (Method B)	12
Nail Pull Resistance (Method B)	13
Humidified Deflection	14
End Squareness	15
Nominal Thickness	16
Recessed- or Tapered Edge Depth	17
Width	18
Length	19
Water Resistance of Core-Treated Water-Repellent Gypsum Panel Products	20
Surface Water Resistance of Gypsum Panel Products with Water-Repellent Surfaces	21

1.3 The text of these test methods references notes and footnotes that provide explanatory material. These notes and footnotes, excluding those in tables and figures, shall not be considered as requirements of these test methods.

1.4 *This standard does not purport to address all of the safety concerns, if any, associated with its use. It is the responsibility of the user of this standard to establish appropriate safety and health practices and determine the applicability of regulatory limitations prior to use.*

2. Referenced Documents

2.1 ASTM Standards:

C 11 Terminology Relating to Gypsum and Related Building Materials and Systems²

¹ These test methods are under the jurisdiction of ASTM Committee C-11 on Gypsum and Related Building Materials and Systems and are the direct responsibility of Subcommittee C11.01 on Specifications and Test Methods for Gypsum Products.

Current edition approved ~~Jan. 10, 2003~~, June 10, 2003. Published ~~March 2000~~, August 2003. Originally published as C 473 – 61, approved in 1961. Last previous edition C 473 – 99^ε, approved in 2000 as C 473 – 00.

*A Summary of Changes section appears at the end of this standard.

D 3285 Test Method for Water Absorptiveness of Nonfibulose Paper and Paperboard (Cobb Test)³
 E 4 Practices for Force Verification of Testing Machines⁴

3. Terminology

3.1 Definitions used in these test methods are in accordance with Terminology C 11.

3.2 *Definitions of Terms Specific to This Standard:*

3.2.1 *edge, n*—the paper-bound edge, or long edge, as manufactured.

3.2.2 *ends, n*—the end perpendicular to the paper-bound edge or long edge.

4. Sampling

4.1 For use in these test methods, a sample shall consist of not less than 0.25 % of the number of gypsum panel products in a shipment, but not less than three gypsum panel products. Test specimens shall be taken from the sample lot as indicated in each method.

5. Conditioning

5.1 Condition specimens to constant weight at a temperature of $85 \pm 15^\circ\text{F}$ ($29.5 \pm 8.5^\circ\text{C}$) and relative humidity of $50 \pm 2\%$ (Note 1). Test specimens individually after constant weight is reached and within 10 min upon removal from the conditioning chamber.

NOTE 1—Laboratory test results indicated that conditioning temperatures may range from 70 to 100°F (21 to 38°C) without significantly affecting the results. However, relative humidity is critical. This is the reason for testing specimens within 10 min upon removal from the conditioning chamber.

Method A—Constant Rate of Loading

INTRODUCTION

The following procedures are applicable to so-called “shot machines” that utilize lead or steel shot that applies a load to the specimen at a constant stress rate or any other device that applies the load at a constant stress rate.

6. Apparatus—Method A

6.1 *Testing Machine*— Apply the test load at a uniform rate of 1 lbf/s (4.45 N/s) $\pm 10\%$. Apply the load with a device independent of manual control of the rate of loading during an individual sample test (see Fig. 1). The deformation of the specimen controls the cross head speed.

7. Flexural Strength (Method A)

7.1 *Summary of Test Method*—Flexural properties of gypsum panel products are evaluated by supporting the specimen near the ends and applying a transverse load midway between the supports.

7.2 *Significance and Use*—This test method covers a procedure for evaluating the ability of gypsum panel products to withstand flexural stresses during handling or use of the material. This test method is used to determine compliance with gypsum panel product specifications. The degree of correlation between this test and service performance has not been fully determined.

7.3 *Apparatus*—See Section 6.1.

7.3.1 *Specimen Supports*—All specimen bearing supports and load surfaces shall be true, shall engage the full width of the test specimen, shall be of such strength they will not deform under the test load, and shall be rounded to a radius of 0.125 in. (3.2 mm). The specimen supports shall be spaced 14 ± 0.016 in. (356 ± 0.41 mm) on centers measured at the points of surface contact with

² Annual Book of ASTM Standards, Vol 04.01.

³ Annual Book of ASTM Standards, Vol 15.09.

⁴ Annual Book of ASTM Standards, Vol 03.01.

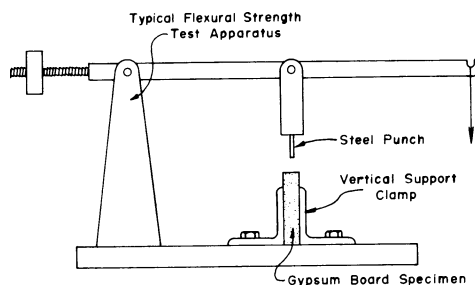

FIG. 1 Apparatus Schematic for Core, End, and Edge Hardness Test

the specimen. The supports shall be attached to a plate that shall be rigidly attached to the test apparatus. The supports shall be parallel to each other and perpendicular to the long dimension of the test specimen. The bearing surface of the end supports shall be on the same plane to ensure contact along the entire bearing surfaces. Supports shall be not less than 12 in. (305 mm) in length. When a load is being applied, the loading bar shall be in contact with the full width of the specimen. The load-bearing surface shall be parallel to the bearing surface of the specimen supports. The specimen and supports shall be located so that the vertical axis through the center of the load-bearing surface passes through the specimen at one half of the specimen width and one half of the distance between the supports.

7.4 *Sampling*—Sampling shall be in accordance with Section 4.

7.5 *Test Specimens*:

7.5.1 Cut four specimens, each 12 in. (305 mm) by approximately 16 in. (406 mm) from each gypsum panel product in the sample, two having the 16-in. dimension parallel to the edge and two having the 16-in. dimension perpendicular to the edge. Cut the specimens not less than 4 in. (102 mm) away from the ends and edges of the gypsum panel product except where the product is 24-in. or less in width, where it is impossible to do so.

7.5.2 Condition specimens in accordance with Section 5.

7.6 *Procedure*:

7.6.1 Use the apparatus in 7.3, supporting each specimen centrally on the fixed parallel bearings, 14-in. (356 mm) on centers, and apply the load on a similar bearing midway between the supports. Position perforated gypsum lath so the load is not applied over perforations.

7.6.2 For specimens with the long dimension parallel to the edge, test one specimen from each gypsum panel product face up and the other face down. For specimens with the long dimension perpendicular to the edge, test one specimen from each gypsum panel product face up and the other face down.

7.6.3 For gypsum panel products with surfacing material, the load is determined at the time of transverse failure of the surfacing material and core through the thickness of the specimen. The specimens shall not show a break in the bond between the surfacing and the core before transverse failure of the gypsum panel product. If a single specimen fails, test two additional specimens from the same sample, and, if either one of the two specimen fail, the sample has failed. For gypsum panel products without surfacing material, the load is determined at the time of transverse failure through the thickness of the specimen.

7.7 *Report*—Calculate and report the average breaking load in pound-force or newtons for each test condition, rounded to the nearest 1 lbf (N). The test conditions are: (1) parallel, face up; (2) parallel, face down; (3) perpendicular, face up; and, (4) perpendicular, face down.

7.8 *Precision and Bias*—The precision and bias for this test method has not been determined.

8. Core, End, and Edge Hardness (Method A)

8.1 *Summary of Test Method*—The core, end, and edge hardness of gypsum panel products is evaluated by determining the force required to push a steel punch into the area of test.

8.2 *Significance and Use*—This test method covers a procedure for evaluating the ability of the gypsum panel product core, ends, and edges to resist crushing during handling or use of the material. This test method is used to determine compliance with gypsum panel product specifications. The degree of correlation between these test methods and service performance has not been determined.

8.3 *Apparatus*—See 6.1. Clamp or secure the specimen to the base of the test apparatus shown in Fig. 1 with the face of the specimen perpendicular to the base of the test apparatus and parallel to the movement of the steel punch. Secure the steel punch to the moving head of the test apparatus, positioned so that its center axis is parallel with the line of travel and so that the punch is inserted into the core equidistant from the surfaces of the specimen. Use a steel punch 0.099 ± 0.003 in. (2.515 ± 0.076 mm) in diameter and more than ½ in. (12.7 mm) long with the bearing surface machined to a 90° angle in reference to the punch center line (see Fig. 1 for test setup schematic).

8.4 *Sampling*—Sampling shall be in accordance with Section 4.

8.5 *Test Specimens*:

8.5.1 *Specimens for Core Hardness* —Using a table or band saw, cut one specimen from the center of each of the three gypsum panel product samples approximately 12 by not less than 3 in. (305 by 76 mm), with the 12-in. dimension perpendicular to the edges of the products, for a total of not less than three specimens. The smaller, not less than 3 in., dimension will vary depending on the specific punch length and opening in the testing machines. Place the sample in the tester, with the loading arm in a horizontal position and with the punch resting on the specimen. Saw cuts along the 12-in. dimension shall be smooth and square with the smaller (not less than 3-in.) dimension, as well as with the specimen.

8.5.2 *Specimens for End Hardness* —Cut specimens the same size and method as described in 8.5.1 from one mill-cut end of the gypsum panel product, with the 12-in. (305-mm) dimension perpendicular to the edges, for a total of not less than three specimens, and run tests only on the mill-cut end of the specimens.

8.5.3 *Specimens for Edge Hardness* —Cut specimens the same size and method as described in 8.5.1 from the opposite edges of each gypsum panel product, with the 12 in. (305 mm) dimension of the specimens parallel with the edges, for a total of not less than six specimens. For gypsum panel products with surfacing material, cut a ¼ to ½-in. (6 to 13-mm) strip of surfacing material from the edge of the test specimens exposing the core for test. Remove as little of the core as possible when removing the surfacing

material. Prepare the first test area $2 \pm \frac{1}{2}$ in. (51 ± 13 mm) from one edge of the specimen, with the next two test areas approximately 4 in. (102 mm) apart.

8.5.4 Condition specimens in accordance with Section 5.

8.6 *Procedure*—Using the apparatus in 8.3, clamp or secure the specimen in a fixed vertical position on its 12 in. (305 mm) dimension edge (see Fig. 1 for test setup schematic). If necessary, modify the flexural strength test equipment to conduct the core, end, and edge hardness test). Place this test surface not less than 1 in. (25 mm) above the grip of the specimen holder. Conduct three tests spaced approximately 4 in. (102 mm) apart on each specimen, with the first test area $2 \pm \frac{1}{2}$ in. (51 ± 13 mm) from one edge of the specimen. Position the steel punch over the test area and apply the load. Report as the core, end, or edge hardness the load required to push the steel punch a distance of $\frac{1}{2}$ in. (13 mm) into the core of the specimen.

8.6.1 *Procedure for Core Hardness* —Test either of the 12-in. (305-mm) saw cut edges, for a total of not less than nine tests (three per specimen).

8.6.2 *Procedure for End Hardness* —Test the 12-in. (305-mm) mill-cut end, for a total of not less than nine tests (three per specimen).

8.6.3 *Procedure for Edge Hardness* —Test areas along the 12-in. (305-mm) edge, for a total of not less than eighteen tests (three per specimen). For products with surfacing material, test where the surfacing material has been removed.

8.7 *Report*—Report the core, end, and edge hardness individually as the average load in pounds-force or newtons rounded to the nearest 1 lbf (N). Discard any single test value that varies from the average by more than 15 % and repeat the test on the same sample to obtain a new value.

8.8 *Precision and Bias*—The precision and bias of this test method has not been determined.

9. Nail Pull Resistance (Method A)

9.1 *Summary of Test Method*—The ability of gypsum panel products to resist nail pull-through is evaluated by determining the load required to push a standard nail head through the product.

9.2 *Significance and Use*—This test method covers a procedure for evaluating the ability of gypsum panel products to resist nail pull-through by determining the load required to force a standard nail head through the product. This test method is used to determine compliance with gypsum panel product specifications. The degree of correlation between these test methods and service performance has not been determined.

9.3 *Apparatus*—See 6.1. This apparatus shall be used with either of the specimen support plates in 9.3.1 or 9.3.2.

9.3.1 Fig. 2 shows a schematic of a nail pull resistance apparatus adaptable to a typical flexural strength apparatus commonly used in the gypsum industry. The specimen support plate shall have a 3-in. (76-mm) diameter hole in the center. The support plate shall be not less than 6 by 6 in. (152 by 152 mm). It shall be attached to the apparatus as necessary to maintain the surface of the plate perpendicular to the travel of the test nail. The support plate must also be located so that the vertical axis through the center of the nail shank passes through the center of the hole in the support plate. The test nail shank shall be 0.099 ± 0.003 in. (2.515 ± 0.076 mm) in diameter and the nail head shall be 0.250 ± 0.005 in. (6.350 ± 0.127 mm) in diameter. The nail shall be attached at the head to the movable cross head of the test apparatus. This attachment shall not exceed the diameter of the nail head and shall be placed directly over the head. It shall also be attached so that the vertical axis through the nail shank is parallel with the travel.

9.3.2 Fig. 3 shows a schematic of an alternate nail pull resistance apparatus adaptable to a typical flexural strength apparatus commonly used in the gypsum industry. This apparatus mirrors all of the requirements of 9.3.1, except that the nail is not attached at the head to the movable cross head of the test apparatus. The alternate apparatus utilizes a machined plunger with the nail head and shank incorporated as an integral part of the plunger. The plunger fits into a bushing that keeps the nail aligned perpendicular to the test specimen.

9.4 *Sampling*—Sampling shall be in accordance with Section 4.

9.5 *Test Specimens*:

9.5.1 Cut five specimens 6 by 6 in. (152 by 152 mm) from a strip cut across the width of each 48-in. (1220-mm) gypsum panel product starting not less than 4 in. (102 mm) in from the edge. Cut a total of five specimens from more than one full width strip from gypsum panel products less than 38 in. (965 mm) wide. Do not cut the specimen closer than 3 in. (76 mm) from the product edges.

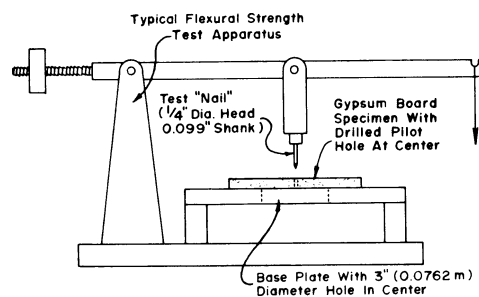
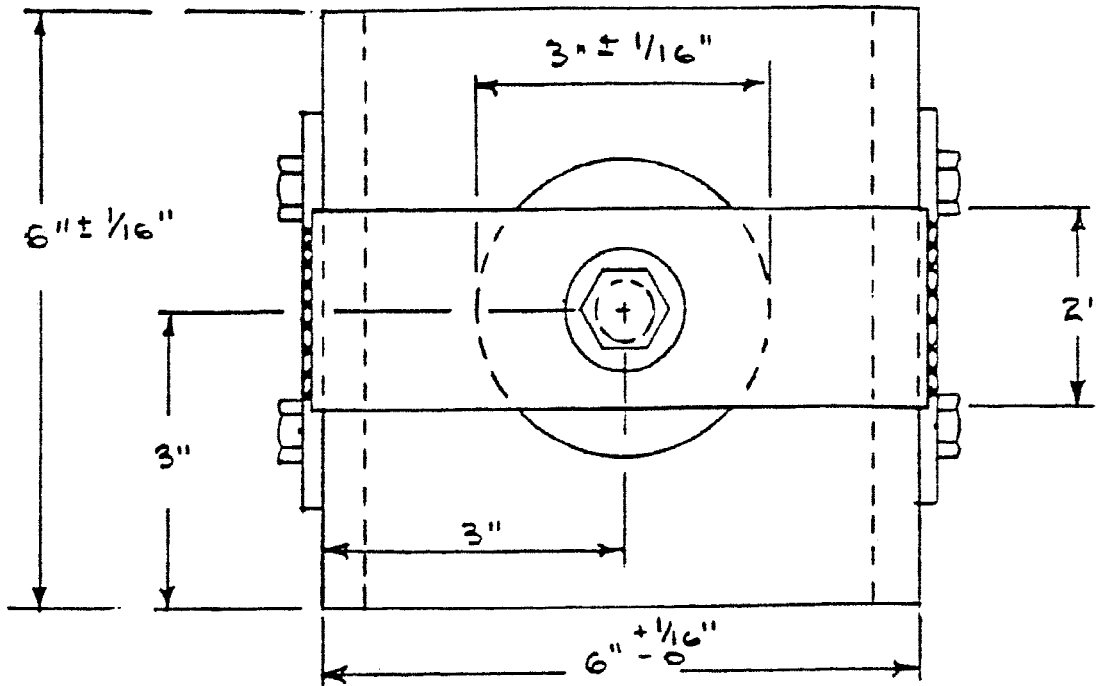

FIG. 2 Apparatus Schematic for Nail-Pull Resistance Test

TOP VIEW



LOAD FROM BAR ATTACHED TO TRANSVERSE TESTER ARM

BRONZE OR BRASS BUSHING PRESS FIT WITH .001" CLEARANCE FOR PLUNGER

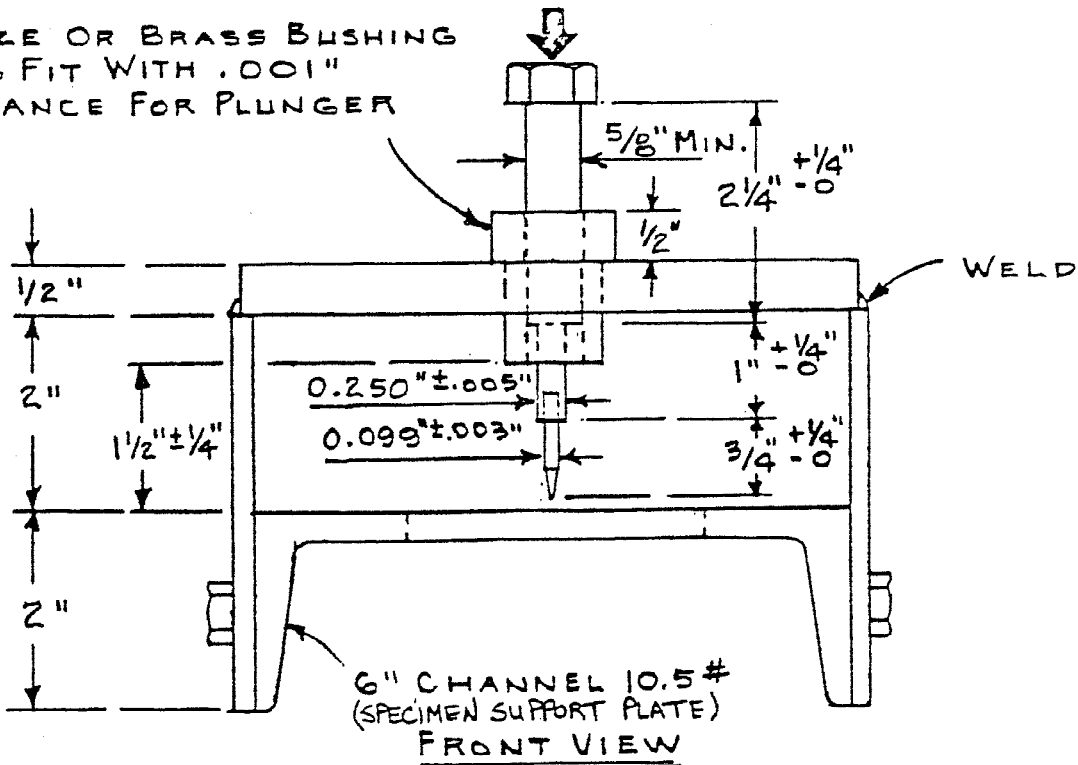

FIG. 3 Nail Pull Specimen Support Plate

9.5.2 Drill a $\frac{7}{64}$ -in. (2.778-mm) diameter pilot hole through the thickness of the gypsum panel product in the center of each test specimen and perpendicular to the surface.

9.5.3 Condition specimens in accordance with Section 5.

9.6 Procedure—Using the apparatus in 9.3, center the specimen face up on the base plate and manually lower the test nail, inserting the nail shank in the pilot hole, until the nail head is flush with the surface of the specimen. Apply the load until the

maximum load is achieved. Normally, this will occur as the nail head breaks through the gypsum panel product surface.

9.7 *Report*—Calculate the average maximum load in pounds-force or newtons, rounded to the nearest 1 lbf (N). Discard any single test that varies from the average by more than 15 %. If more than 15 % of the test values are discarded, repeat the test.

9.8 *Precision and Bias*—The precision and bias of this test method has not been determined.

Method B—Constant Rate of Cross Head Speed

INTRODUCTION

The following procedures are applicable to so-called universal test machines. These instruments often use electronic load cells and data acquisition equipment to gather information about the specimen being tested. The instruments generally in use move the cross head at a constant speed, as opposed to having the deformation on the specimen control cross head speed, which would be a true constant rate of strain instrument.

10. Apparatus

10.1 *Testing Machine*, of any type that is of sufficient capacity and that is capable of providing a rate of loading at a strain rate of 1.0 in./min \pm 5 s (25 mm/min \pm 5 s). The load platform of the test equipment shall be of sufficient size to accept the specimen holder and load applying apparatus. The testing machine shall be power operated and shall apply the load continuously and without shock.

10.2 The test apparatus shall be verified according to Practices E 4, the three sections titled “Basis of Verification,” “Corrections,” and “Time Interval Between Verifications.”

10.3 *Load-Indicating Equipment*, capable of reading to 1-lbf (4.45-N) increments, shall be provided for the test apparatus. A means shall be provided to indicate the maximum load attained during the test.

11. Flexural Strength (Method B)

11.1 *Summary of Test Method*—Flexural properties of gypsum panel products are evaluated by supporting the specimen near the ends and applying a transverse load midway between the supports.

11.2 *Significance and Use*—This test method covers a procedure for evaluating the ability of gypsum panel products to withstand flexural stresses during handling or use of the material. This test method is used to determine compliance with gypsum panel product specifications. The degree of correlation between this test and service performance has not been fully determined.

11.3 *Apparatus*—See Section 10.

11.3.1 *Specimen Supports*—All bearing supports and load surfaces shall be true, shall engage the full width of the test specimen, shall be of such strength they will not deform under the test load, and shall be rounded to a radius of 0.125 in. (3.2 mm). The specimen supports shall be spaced 14 ± 0.016 in. (356 ± 0.41 mm) on centers measured at the points of surface contact with the specimen. The supports shall be attached to a plate that shall be rigidly attached to the test apparatus. Test specimen supports shall be parallel to each other and perpendicular to the long dimension of the test specimen. The bearing surface of the end supports shall be on the same plane to ensure contact along the entire bearing surfaces. Supports shall be not less than 12 in. (305 mm) in length. When a load is being applied, the loading bar shall be in contact with the full width of the specimen. The load-bearing surface shall be parallel to the bearing surface of the specimen supports. The specimen and specimen supports shall be located so that the vertical axis through the center of the load-bearing surface passes through the specimen at one half of the specimen width and one half of the distance between the supports (see Fig. 4).

11.4 *Sampling*—Sampling shall be in accordance with Section 4.

11.5 *Test Specimen:*

11.5.1 Cut four specimens, each 12 in. (305 mm) by approximately 16 in. (406 mm) from each gypsum panel product in the sample, two having the 16-in. dimension parallel to the edge and two having the 16-in. dimension perpendicular to the edge. Cut the specimens not less than 4 in. (102 mm) away from the ends and edges of the gypsum panel product except where the product is 24-in. or less in width, where it is impossible to do so.

11.5.2 Condition specimens in accordance with Section 5.

11.6 *Procedure:*

11.6.1 Use the apparatus in 11.3, supporting each specimen centrally on the fixed parallel supports, 14-in. (356-mm) on centers, and apply the load on a similar bearing midway between the supports. Position perforated gypsum lath so the load is not applied over perforations.

11.6.2 For specimens with the long dimension parallel to the edge, test one specimen from each gypsum panel product face up and the other face down. For specimens with the long dimension perpendicular to the edge, test one specimen from each gypsum panel product face up and the other face down.

11.6.3 For gypsum panel products with surfacing material, the load is determined at the time of transverse failure of the surfacing material and core through the thickness of the specimen. The specimens shall not show a break in the bond between the surfacing and the core before transverse failure of the gypsum panel product. If a single specimen fails, test two additional specimens from the same sample, and, if either one of the two specimens fail, the sample has failed. For gypsum panel products without surfacing material, the load is determined at the time of transverse failure through the thickness of the specimen.

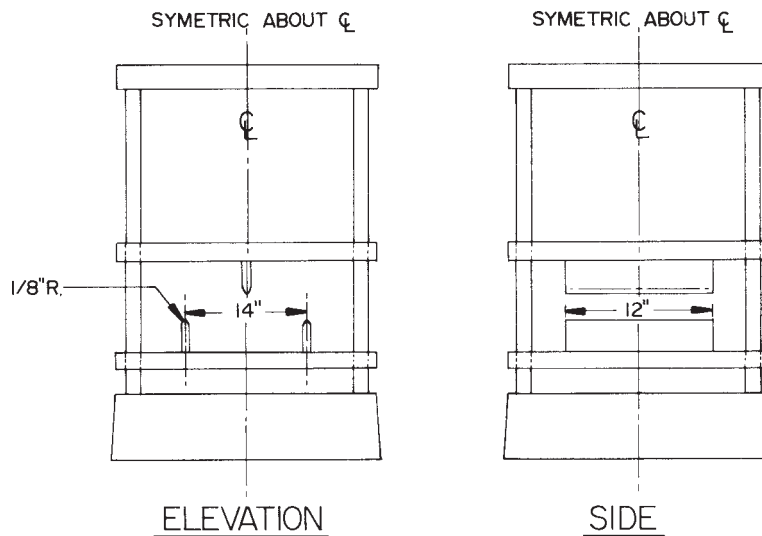

FIG. 4 Testing Machine

11.7 *Report*—Calculate and report the average breaking load in pounds-force or newtons for each test condition, rounded to the nearest 1 lbf (N). The test conditions are: (1) parallel, face up; (2) parallel, face down; (3) perpendicular, face up; and, (4) perpendicular, face down.

11.8 *Precision and Bias:*

11.8.1 *Precision*—The 95 % repeatability limit of the Parallel, Face Up (Method B) test is the test result ± 4.796 lbf [21.33 N]. The 95 % reproducibility limit of the Parallel, Face Up (Method B) test is the test result ± 8.992 lbf [40.00 N].

11.8.2 *Precision*—The 95 % repeatability limit of the Parallel, Face Down (Method B) test is the test result ± 5.087 lbf [22.63 N]. The 95 % reproducibility limit of the Parallel, Face Down (Method B) test is the test result ± 7.370 lbf [32.78 N].

11.8.3 *Precision*—The 95 % repeatability limit of the Across, Face Up (Method B) test is the test result ± 10.290 lbf [45.77 N]. The 95 % reproducibility limit of the Across, Face Up (Method B) test is the test result ± 13.368 lbf [59.46 N].

11.8.4 *Precision*—The 95 % repeatability limit of the Across, Face Down (Method B) test is the test result ± 11.704 lbf [52.06 N]. The 95 % reproducibility limit of the Across, Face Down (Method B) test is the test result ± 19.429 lbf [86.42 N].

11.8.5 *Bias*—No information can be presented on the bias of the procedure in these test methods for measuring the Flexural Strength (Method B) because there is no material having an accepted reference value.

12. Core, End, and Edge Hardness (Method B)

12.1 *Summary of Test Method*—The core, end, and edge hardness of gypsum panel products is evaluated by determining the force required to push a steel punch into the area of test.

12.2 *Significance and Use*—This test method covers a procedure for evaluating the ability of the gypsum panel product core, ends, and edges to resist crushing during handling or use of the material. This test method is used to determine compliance with gypsum panel product specifications. The degree of correlation between this test method and service performance has not been fully determined.

12.3 *Apparatus*—See Section 10.

12.3.1 A means of securing the specimen to the base of the test apparatus shall be provided. The face of the specimen shall be perpendicular to the base of the test apparatus and parallel to the movement of the steel punch. The steel punch shall be secured to the moving head of the test apparatus. It shall be positioned so that its center axis is parallel with the line of travel. It also shall be positioned so that the punch is inserted into the core equidistant from the surfaces of the specimen. The steel punch shall be 0.099 ± 0.003 in. (2.515 ± 0.076 mm) in diameter and more than $\frac{1}{2}$ in. (12.7 mm) long with the bearing surface machined to a 90° angle in reference to the punch center line (see Fig. 5 and Fig. 6).

12.4 *Sampling*—Sampling shall be in accordance with Section 4.

12.5 *Test Specimens:*

12.5.1 *Specimens for Core Hardness*—Using a table or band saw, cut a specimen not less than 12 by 3 in. (305 by 76 mm) from the center of each gypsum panel product, for a total of not less than three specimens. The 12-in. (305-mm) dimension shall be perpendicular to the edges of the gypsum panel product. Cuts along the 12 in. (305 mm) dimension shall be smooth and perpendicular to the face of the specimen.

12.5.2 *Specimens for End Hardness*—Cut a specimen not less than 12 by 3 in. (305 by 76 mm) from one mill-cut end of each gypsum panel product, for a total of not less than three specimens. Cut the 12-in. (305-mm) dimension perpendicular to the edges of the gypsum panel product.

12.5.3 *Specimens for Edge Hardness*—Cut a specimen not less than 12 by 3 in. (305 by 76 mm) from each edge of each gypsum panel product, for a total of not less than six specimens. Cut the 12-in. (305-mm) dimension parallel to the edge of the gypsum

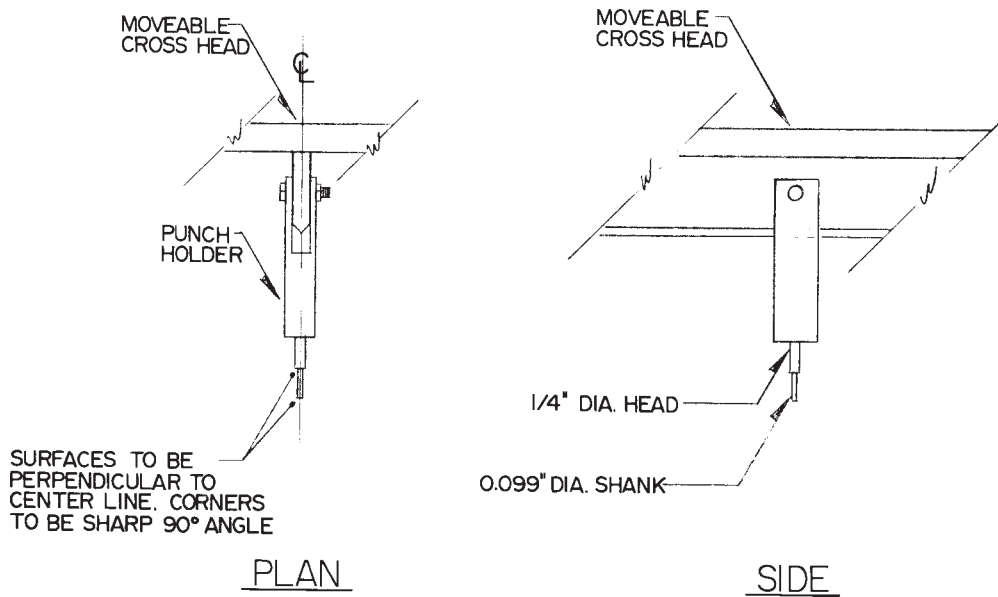

FIG. 5 Test Setup—Punch for Hardness and Nail Pull Resistance

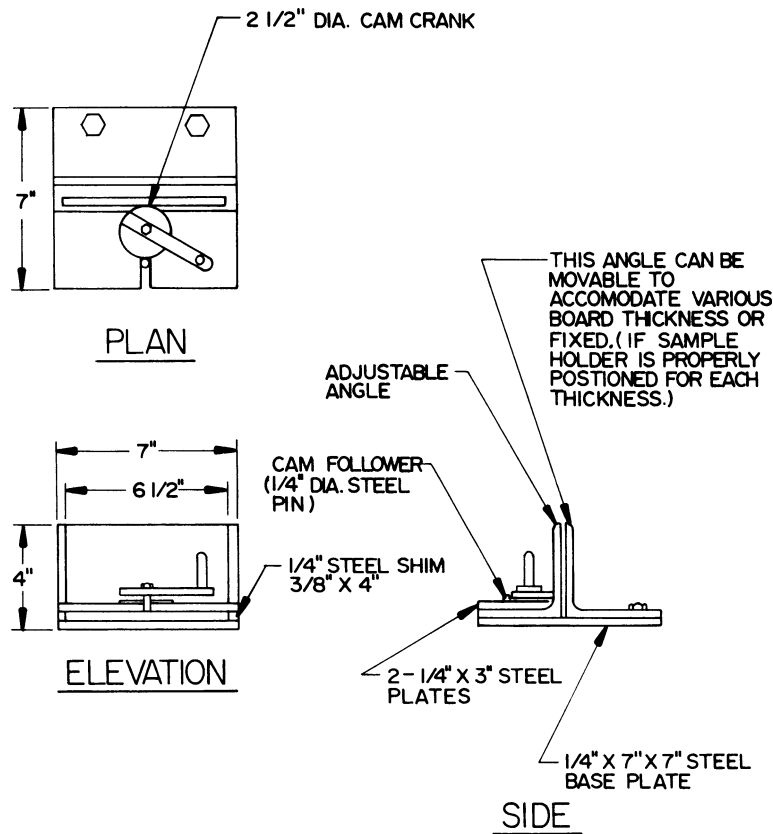

FIG. 6 Test Setup—Sample Holder for Hardness Test

panel product. For gypsum panel products with surfacing material, cut a 1/4 to 1/2-in. (6 to 13-mm) strip of surfacing material from the edge of the test specimens exposing the core for test. Remove as little of the core as possible when removing the surfacing material. Prepare the first test area $2 \pm 1/2$ in. (51 ± 13 mm) from one edge of the specimen, with the next two test areas spaced approximately 4 in. (102 mm) apart.

12.5.4 Condition specimens in accordance with Section 5.

12.6 Procedure—Using the apparatus in 12.3, clamp or secure the specimen in a fixed vertical position on its 12 in. (305 mm) dimension edge. If necessary, modify the flexural strength test equipment to conduct the core, end, and edge hardness test. Place this test surface not less than 1 in. (25 mm) above the grip of the specimen holder. After the specimen is in place, zero the load

indicator. Conduct three tests spaced approximately 4 in. (102 mm) apart on each specimen, with the first test area $2 \pm \frac{1}{2}$ in. (51 ± 13 mm) from one edge of the specimen. Position the steel punch over the test area and apply the load. Report as the core, end, or edge hardness the load required to push the steel punch a distance of $\frac{1}{2}$ in. (13 mm) into the core of the specimen.

12.6.1 *Procedure for Core Hardness*—Test either of the 12-in. (305-mm) saw cut ends, for a total of not less than nine tests (three per specimen).

12.6.2 *Procedure for End Hardness*—Test the 12-in. (305-mm) mill-cut end, for a total of not less than nine tests (three per specimen).

12.6.3 *Procedure for Edge Hardness*—Test areas along the 12-in. (305-mm) edge, for a total of not less than eighteen tests (three per specimen). For products with surfacing material, test where the surfacing material has been removed.

12.7 *Report*—Report the core, end, and edge hardness individually as the average load in pounds-force or newtons rounded to the nearest 1 lbf (N). Discard any single test value that varies from the average by more than 15 % and repeat the test on the same sample to obtain a new value.

12.8 *Precision and Bias:*

12.8.1 *Precision*—The 95 % repeatability limit of the End Hardness (Method B) test is the test result ± 8.103 lbf [36.04 N]. The 95 % reproducibility limit of the End Hardness (Method B) test is the test result ± 9.725 lbf [43.56 N].

12.8.2 *Precision*—The 95 % repeatability limit of the Core Hardness (Method B) test is the test result ± 4.231 lbf [18.82 N]. The 95 % reproducibility limit of the Core Hardness (Method B) test is the test result ± 9.668 lbf [43.01 N].

12.8.3 *Precision*—The 95 % repeatability limit of the Edge Hardness (Method B) test is the test result ± 7.730 lbf [34.38 N]. The 95 % reproducibility limit of the Edge Hardness (Method B) test is the test result ± 23.031 lbf [102.45 N].

12.8.4 *Bias*—No information can be presented on the bias of the procedure in these test methods for measuring the End, Core, and Edge Hardness because there is no material having an accepted reference value.

13. Nail Pull Resistance (Method B)

13.1 *Summary of Test Method*—The ability of gypsum panel products to resist nail pull-through is evaluated by determining the load required to push a standard nail head through the product.

13.2 *Significance and Use*—This test method covers a procedure for evaluating the ability of gypsum panel products to resist nail pull-through by determining the load required to force a standard nail head through the product. This test method is used to determine compliance with gypsum panel product specifications. The degree of correlation between these test methods and service performance has not been determined.

13.3 *Apparatus*—See Section 10. The apparatus shall be used with either of the specimen support plates in 13.3.1 or 13.3.2.

13.3.1 *Specimen Support Plate*, shall be true and have a 3-in. (76-mm) diameter hole in the center. The support plate shall be not less than 6 by 6 in. (152 by 152 mm). It shall be attached to the apparatus as necessary to maintain the surface of the plate perpendicular to the travel of the test nail. The support plate must also be located so that the vertical axis through the center of the nail shank passes through the center of the hole in the support plate. The test nail shank shall be 0.099 ± 0.003 in. (2.515 ± 0.076 mm) in diameter and the nail head shall be 0.250 ± 0.005 in. (6.350 ± 0.127 mm) in diameter. The nail shall be attached at the head to the movable cross head of the test apparatus. This attachment shall not exceed the diameter of the nail head and shall be placed directly over the head. It shall also be attached so that the vertical axis through the nail shank is parallel with the travel. See Figs. 5 and 7 for examples of the test setup configuration.

13.3.2 Fig. 3 shows a schematic of an alternate nail pull resistance apparatus adaptable to a typical flexural strength apparatus commonly used in the gypsum industry. This apparatus mirrors all of the requirements of 13.3.1, except that the nail is not attached

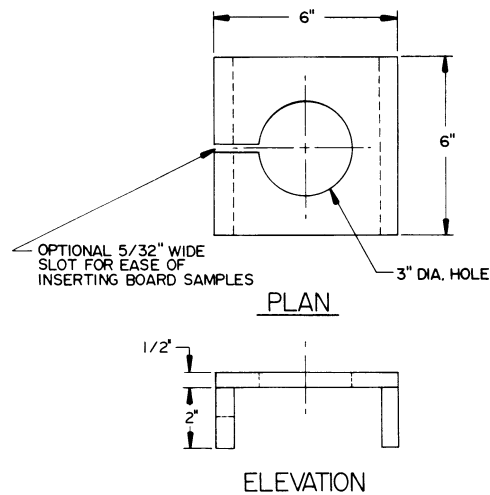

FIG. 7 Test Setup—Sample Holder for Nail Pull Resistance

at the head to the movable cross head of the test apparatus. The alternate apparatus utilizes a machined plunger with the nail head and shank incorporated as an integral part of the plunger. The plunger fits into a bushing that keeps the nail aligned perpendicular to the test specimen.

13.4 *Sampling*—Sampling shall be in accordance with Section 4.

13.5 *Test Specimens*:

13.5.1 Cut five specimens 6 by 6 in. (152 by 152 mm) from a strip cut across the width of each 48-in. (1220-mm) gypsum panel product starting not less than 4 in. (102 mm) in from the edge. Cut a total of five specimens from more than one full width strip from gypsum panel products less than 38 in. (965 mm) wide. Do not cut the specimen closer than 3 in. (76 mm) from the product edges.

13.5.2 Drill a 7/64-in. (2.778-mm) diameter pilot hole through the thickness of the gypsum panel product in the center of each test specimen and perpendicular to the surface.

13.5.3 Condition specimens in accordance with Section 5.

13.6 *Procedure*—Using the apparatus in 13.3, place the specimen on the specimen support plate so that the drilled hole is aligned with the nail shank tip. After the specimen is in place, zero the load indicator. Insert the nail shank into the specimen hole and apply the load until the maximum load is achieved. Normally, this will occur as the nail head breaks through the gypsum panel product surface and is followed by a very significant decrease in load.

13.7 *Report*—Calculate the average maximum load in pounds-force or newtons, rounded to the nearest 1 lbf (N). Discard any single test that varies from the average by more than 15 %. If more than 15 % of the test values are discarded, repeat the test.

13.8 *Precision and Bias* :

13.8.1 *Precision*—The 95 % repeatability limit of the Nail Pull (Method B) test is the test result ± 5.610 lbf [24.95 N]. The 95 % reproducibility limit of the Nail Pull (Method B) test is the test result ± 8.961 lbf [39.86 N].

13.8.2 *Bias*—No information can be presented on the bias of the procedure in these test methods for measuring Nail Pull because there is no material having an accepted reference value.

14. Humidified Deflection

14.1 *Summary of Test Method*—The humidified deflection of gypsum panel products is evaluated by supporting a specimen that has been cut with the long dimension perpendicular to the machine direction, supported horizontally, and subjected to high humidity for 48 h.

14.2 *Significance and Use*—This test method covers a procedure for evaluating the deflection of gypsum panel products when horizontally suspended and subjected to high humidity. This test method is used to determine compliance with gypsum panel product specifications. Since job factors other than high humidity influence the deflection of gypsum panel products, the degree of correlation between this test method and service performance has not been determined.

14.3 *Apparatus*—A humidity cabinet of sufficient size to accommodate test specimens 12 by 24 in. (305 by 610 mm) capable of maintaining an atmosphere of $90 \pm 3^\circ\text{F}$ ($32 \pm 1.7^\circ\text{C}$) and $90 \pm 3\%$ relative humidity for 48 h.

14.4 *Sampling*—Sampling shall be in accordance with Section 4.

14.5 *Test Specimens*:

14.5.1 Cut two specimens 12 by 24 in. (305 by 610 mm) from each gypsum panel product in the sample so the 12-in. dimension is parallel to the edges. Cut specimens not less than 12-in. away from the ends and edges of gypsum panel products 48 in. (1220 mm) or more in width. Cut specimens from the center of gypsum panel products that are narrower than 48 in. (1220 mm) as noted in Fig. 8.

14.5.2 Condition specimens in accordance with Section 5.

14.6 *Procedure*—Suspend each specimen face down on parallel and level bearing edges, having 1/8-in. (3.2-mm) radii, 12 in. (305 mm) long, and 23 in. (584 mm) apart in the humidity cabinet in an atmosphere of $90 \pm 3^\circ\text{F}$ ($32 \pm 1.7^\circ\text{C}$) and $90 \pm 3\%$

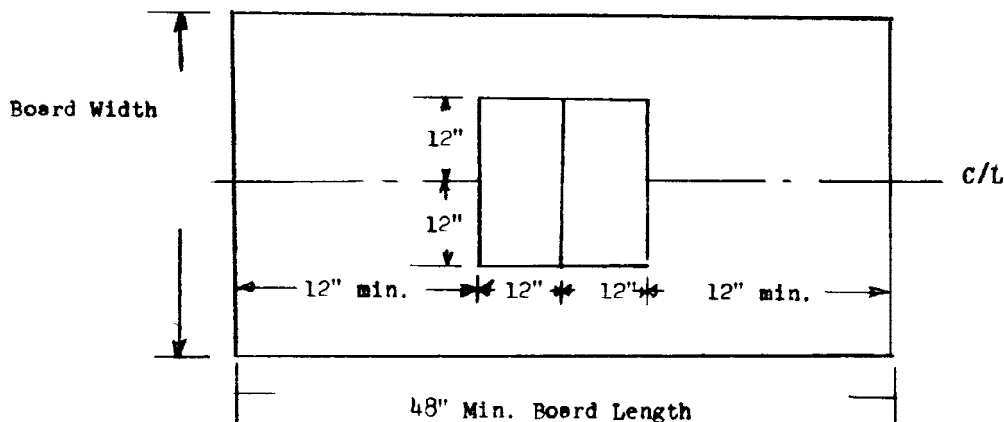

FIG. 8 Sample Selection Detail for Humidified Deflection Test

relative humidity for 48 h. Measure the humidified deflection of each specimen, while suspended on the bearing edges, as the distance between a straightedge placed on the top end edges of the gypsum panel product and the upper surface of the product at its center. Take measurements to the nearest $\frac{1}{16}$ in. (1.6 mm).

14.7 *Report*—Report the humidified deflection as the average of the specimens to the nearest $\frac{1}{8}$ in. (3 mm).

14.8 *Precision and Bias*—The precision and bias of this test method has not been determined.

15. End Squareness

15.1 *Summary of Test Method*—The end squareness of gypsum panel products is evaluated by drawing a line perpendicular to the edge of a full width specimen to its opposite edge and measuring the length of the side of the triangle formed.

15.2 *Significance and Use*—This test method covers a procedure for determining the end squareness of gypsum panel products. This test method is used to determine compliance with gypsum panel product specifications. The degree of correlation between this test method and service performance has not been determined.

15.3 *Apparatus*—A T-shaped or L-shaped square for drawing or testing right angles. The long edge of the square shall be not less than 48 in.

15.4 *Sampling*—Sampling shall be in accordance with Section 4.

15.5 *Test Specimens*—Use full-size gypsum panel products with undamaged ends for test specimens.

15.6 *Procedure*—Place one edge of the square flush against the edge of the gypsum panel product with the apex of the square at one corner of the product. Determine the distance b , to the nearest $\frac{1}{16}$ in. (1.6 mm) at the specified distance a . Distance is measured from the apex of the square (see Fig. 9).

15.7 *Report*—Report the average of distance b to the nearest $\frac{1}{8}$ in. (3.2 mm).

15.8 *Precision and Bias*—The precision and bias of this test method has not been determined.

16. Thickness

16.1 *Summary of Test Method*—The nominal thickness of gypsum panel products is evaluated by measuring the thickness of the specimen with a micrometer.

16.2 *Significance and Use*—This test method covers a procedure for determining the thickness of gypsum panel products, and is used to determine compliance with gypsum panel product specifications. The degree of correlation between this test method and service performance has not been determined.

16.3 *Apparatus*—A micrometer gage for determining the thickness measurement to 0.001 in. (0.025 mm). The micrometer shall be a 1-in. (25.4-mm) hand micrometer with $\frac{1}{4}$ -in. (6.35-mm) diameter anvils graduated to 0.01 in. (0.25 mm).

16.4 *Sampling*—Sampling shall be in accordance with Section 4.

16.5 *Test Specimens:*

16.5.1 Use full-size gypsum panel products for test specimens.

16.5.2 Mark the product to be tested, score on both sides, and break at 12 in. (305 mm) from each end, discarding the two ends prior to testing. Retain the remaining part of each gypsum panel product as a test specimen.

16.6 *Procedure*—Mark measurement points at approximately equal points across the width at each end of the gypsum panel product excluding the tapered, beveled, or recessed edges if applicable. Engage the micrometer firmly, but do not indent the surfacing material of the gypsum panel product. Measure the thickness of the gypsum panel product with the micrometer not less than $\frac{1}{2}$ in. (13 mm) from cut ends. Take a minimum of not less than seven readings at each end of the 54-in. (1370-mm) wide gypsum panel product, six readings at each end of the 48-in. (1220-mm) wide gypsum panel product, five readings at each end of the 32-in. (813-mm) wide gypsum panel product, four readings at each end of the 24-in. (610-mm) wide gypsum panel product, or three readings at each end of the 16-in. (406-mm) wide gypsum panel product.

16.7 *Report*—Calculate the nominal thickness of each specimen as the average of the individual micrometer reading taken on each gypsum panel product. Calculate and report the sample thickness as the average measured thickness of all the specimens in the sample to the nearest $\frac{1}{64}$ in. (0.4 mm) and local variations in any one specimen to the nearest $\frac{1}{32}$ in. (0.8 mm).

16.8 *Precision and Bias*—The precision and bias of this test method has not been determined.

17. Recessed- or Tapered-Edge Depth

17.1 *Summary of Test Method*—The recessed- or tapered-edge depth of gypsum panel products is evaluated by comparing the thickness near the edge of the specimen to the thickness in the field of the specimen.

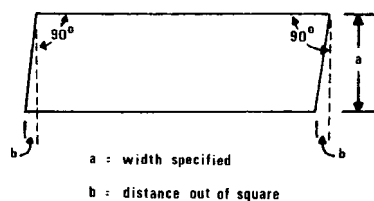

FIG. 9 End Squareness Determination

17.2 *Significance and Use*—This test method provides a procedure for determining the depth of the recess or taper on the edge of gypsum panel products board and is used to determine compliance with gypsum panel product specifications. The degree of correlation between this test method and service performance has not been determined.

17.3 *Apparatus*—Use the micrometer gage described in 16.3. Engage the micrometer firmly but do not indent the surfacing material. Take all readings to the nearest 0.001 in. (0.025 mm) of specimen thickness.

17.4 *Sampling*—Sampling shall be in accordance with Section 4.

17.5 *Specimens*:

17.5.1 Use the same specimens prepared in 16.5, or prepare another set of specimens as indicated in 16.5.

17.6 *Procedure*:

17.6.1 At one corner, determine the thickness 6 in. (152 mm) from the cut end and $\frac{3}{8}$ in. (9.5 mm) from the edge.

17.6.2 Subtract the specimen as determined in 17.6.1 from the average specimen thickness as determined in Section 16.

17.6.3 Repeat the procedure in 17.6.1 and 17.6.2 on the remaining three corners of this specimen and on the remaining two specimens of the sample.

17.6.4 Determine the average recessed or tapered-edge depth from all the individual recessed or tapered-edge depths, as in 17.5.

17.6.5 Determine the variation of any individual recessed or tapered-edge depth from the average as determined in 17.6.4 using the subtraction method.

17.6.6 Reject or discard any individual recessed- or tapered-edge depth calculation, as in 17.6.2, if the variation from average, as in 17.6.5, exceeds 0.050 in. (1.27 mm). To constitute a valid test do not discard more than three individual calculations.

17.7 *Report*—Report the average recessed- or tapered-edge depth as in 17.6.4 after any adjustments for exclusions of data as in 17.6.5 or 17.6.6 to the nearest 0.001 in. (0.025 mm).

17.8 *Precision and Bias*—The precision and bias of this test method has not been determined.

18. Width

18.1 *Summary of Test Method*—The width of gypsum panel products is evaluated by measuring the edge-to-edge dimension of a full size specimen.

18.2 *Significance and Use*—This test method provides a procedure for determining the width of gypsum panel products and is used to determine compliance with gypsum panel products specifications. The degree of correlation between this test method and service performance has not been determined.

18.3 *Apparatus*—Any accurate measuring device capable of measuring the width of the gypsum panel product to the nearest $\frac{1}{32}$ in. (1 mm).

18.4 *Sampling*—Sampling shall be in accordance with Section 4.

18.5 *Test Specimens*—Use full-size gypsum panel products for test specimens.

18.6 *Procedure*:

18.6.1 Measure the width of an individual gypsum panel product by placing the measuring device perpendicular to the edges of the gypsum panel product when measurements are taken. The width of the specimen is the distance between extremities of the edges, so in cases where the edge or edges are beveled (slope in or out) with the face or back of the specimen, or are round, determine the overall distance. One exception is tongue and groove edge specimens, the width of which is the distance between the rip of the tongue and the bottom of the groove.

18.6.2 The width of an individual gypsum panel product is the maximum of two readings taken not less than 48 in. (1220 mm) apart and about 6 in. (152 mm) away from both ends of the specimen. Cut off 6 in. (152 mm) from both ends before taking measurements at ends of tongue and groove-edge specimens.

18.7 *Report*—Report the width as the average width of not less than three specimens to the nearest $\frac{1}{32}$ in. (1 mm).

18.8 *Precision and Bias*—The precision and bias of this test method has not been determined.

19. Length

19.1 *Summary of Test Method*—The length of gypsum panel products is evaluated by measuring the end-to-end dimension of a full size specimen.

19.2 *Significance and Use*—This test method provides a procedure for determining the length gypsum panel products and is used to determine compliance with gypsum panel products specifications. The degree of correlation between this test method and service performance has not been determined.

19.3 *Apparatus*—Any accurate measuring device capable of measuring the width of the gypsum panel product to the nearest $\frac{1}{16}$ in. (2 mm).

19.4 *Sampling*—Sampling shall be in accordance with Section 4.

19.5 *Test Specimens*—Use full-size gypsum panel products for test specimens.

19.6 *Procedure*:

19.6.1 Measure the length of an individual gypsum panel product by placing the measuring device parallel with the edges when measurements are taken. The length of the specimen is the distance between extremities of the ends, so in cases where the ends are beveled, determine the overall distance.

19.6.2 The length of a specimen is the maximum of two readings taken about 3 in. (76 mm) away from both edges of the specimen.

19.7 *Report*—Report the length as the average length of not less than three specimens to the nearest $\frac{1}{8}$ in. (3 mm).

19.8 *Precision and Bias*—The precision and bias of this test method has not been determined.

20. Water Resistance of Core-Treated Water-Repellent Gypsum Panel Products

20.1 *Summary of Test Method*—The water resistance of core-treated water-repellent gypsum panel products is evaluated by immersing the specimen in water for the specified period of time.

20.2 *Significance and Use*—This test method provides a procedure for evaluating the ability of core-treated gypsum panel products to resist water penetration. This test method is used to determine compliance with gypsum panel product specifications. The degree of correlation between this test method and service performance has not been determined.

20.3 *Apparatus*:

20.3.1 *Water Bath*, not less than 16 by 16 by 3 in. (406 by 406 by ~~12.7~~ 75 mm) capable of maintaining the water at a constant temperature of $70 \pm 5^{\circ}\text{F}$ ($21 \pm 0.5^{\circ}\text{C}$).

20.3.2 *Glass Rods*, 0.25 in. (6 mm) in diameter, or other supports capable of keeping the specimens off the bottom of the water bath.

20.4 *Sampling*—Sampling shall be in accordance with Section 4.

20.5 *Test Specimens*:

20.5.1 Prepare a 12 by 12-in. (305 by 305-mm) test specimen cut from the center of the gypsum panel product being tested by scoring and breaking. Cut specimens approximately centered between both edges and not less than 6 in. (152 mm) from either end. Do not treat the edges of the specimen nor damage any surfacing material.

20.5.2 Condition the specimens in accordance with Section 5, except at a temperature of $70 \pm 5^{\circ}\text{F}$ ($21 \pm 2^{\circ}\text{C}$), and then weigh to within 0.5 g.

20.6 *Procedure*:

20.6.1 Position the specimen so that it rests flatwise on glass rods or other supports in the water bath with a head of 1 in. (25 mm) of water over the top of the specimen. If the specimen floats, place sufficient weight on the specimen to keep it in contact with the supports under the 1-in. (25-mm) head of water.

20.6.2 After 2 h have elapsed, remove the specimen from the bath, wipe excess water from the surfaces and edges of the specimen and weigh immediately to within 0.5 g.

20.7 *Report*—Calculate the gain in weight for each specimen as a percentage of the original weight as determined in 20.5.2 to the nearest 1 % and report the average percentage as the water absorption of the gypsum panel product.

20.8 *Precision and Bias*—The precision and bias of this test method has not been determined.

21. Surface Water Resistance of Gypsum Panel Products with Water-Repellent Surfaces

21.1 *Summary of Test Method*—The surface water resistance of gypsum panel products with water-repellent surfaces is evaluated by damming a specified area on the treated surface, filling that area with water, and allowing it to remain undisturbed for the specified time period.

21.2 *Significance and Use*—This test method provides a procedure for evaluating the ability of water-repellent surfacing of gypsum panel products to resist water penetration. This test method is used to determine compliance with gypsum panel product specifications. The degree of correlation between this test method and service performance has not been determined.

21.3 *Apparatus*—A Cobb Tester conditioned to a temperature of $70 \pm 5^{\circ}\text{F}$ ($21 \pm 0.5^{\circ}\text{C}$).

NOTE 2—For a description of the test apparatus see Test Method D 3285. The studs that anchor the metal crossbar may need to be lengthened to accommodate gypsum panel products.

21.4 *Sampling*—Sampling shall be in accordance with Section 4.

21.5 *Test Specimens*:

21.5.1 Cut three specimens 5 in. (127 mm) square from the field of each sample piece of gypsum panel product.

21.5.2 Condition the specimens in accordance with Section 5, except at a temperature of $70 \pm 5^{\circ}\text{F}$ ($21 \pm 2^{\circ}\text{C}$), to constant weight within 0.1 % and then weigh to within 0.05 g.

21.6 *Procedure*:

21.6.1 Place the conditioned test specimens in the Cobb Tester with the side to be exposed to water facing up. Fill the Cobb ring with tap water adjusted to a temperature of $70 \pm 1^{\circ}\text{F}$ ($21 \pm 0.5^{\circ}\text{C}$), resulting in a 1 in. (25.4 mm) head of water above the test area of the specimen.

21.6.2 After 2 h have elapsed, pour the water out of the Cobb ring and remove the specimen from the Cobb Tester. Immediately remove excess water from the specimen by blotting and weigh to the nearest 0.05 g.

21.7 *Report*—Calculate average difference between the dry and wet weights of the test specimens to the nearest 0.1 g and report this as the surface water absorption of the gypsum panel product.

21.8 *Precision and Bias*—The precision and bias of this test method has not been determined.

22. Keywords

22.1 absorption testing; core hardness testing; dimension measurements; edge hardness testing; end hardness testing; flexural strength; gypsum panel products; humidified sag; nail pull testing

APPENDIXES

(Nonmandatory Information)

X1. INTRODUCTION

X1.1 ASTM specifications for gypsum panel products do not contain a specification for weight. The procedure, however, is referenced in other industry standards, and is therefore retained as an appendix item.

X2. WEIGHT

X2.1 *Test Specimens*—A sample shall consist of not less than three full size pieces of the gypsum panel product.

X2.2 *Procedure*—Measure the length and width of each specimen in accordance with Sections 17 and 18. Weight the specimens on a suitable scale and record the weight to the nearest $\frac{1}{4}$ lb (0.1 kg).

X2.3 *Calculation*—Calculate the weight in accordance with the following equation and table:

$$W = \frac{(K \times P)}{(L \times B)}$$

Where:	Meaning of Symbol	Inch-Pound Units	SI Units
W =	weight of specimen	lb/1000 ft ²	kg/100 m ²
L =	length of specimen	in.	mm
B =	width of specimen	in.	mm
P =	weight of specimen	lb	kg
K =	constant	1.44 × 10 ⁵ in. ² /1000 ft ²	1 × 10 ⁸ mm ² / 100 m ²

X2.4 *Report*—Report the weight as the average calculated weight, in lb/1000 ft²(kg/100 m²) of the three gypsum specimens.

SUMMARY OF CHANGES

Committee C-11 has identified the location of selected changes to this standard since the last issue (C 473 – 00) that may impact the use of this standard. (Approved June 10, 2003.)

~~(1) Paragraphs 9.3.2 Added Precision and 13.3.2 were added to reflect an alternate specimen support plate for the nail pull test method. Bias information in sections 11.8, 12.8, and 13.8.~~

~~(2) Note 2 was added in 21.3. Revised section 20.3.1.~~

ASTM International takes no position respecting the validity of any patent rights asserted in connection with any item mentioned in this standard. Users of this standard are expressly advised that determination of the validity of any such patent rights, and the risk of infringement of such rights, are entirely their own responsibility.

This standard is subject to revision at any time by the responsible technical committee and must be reviewed every five years and if not revised, either reapproved or withdrawn. Your comments are invited either for revision of this standard or for additional standards and should be addressed to ASTM International Headquarters. Your comments will receive careful consideration at a meeting of the responsible technical committee, which you may attend. If you feel that your comments have not received a fair hearing you should make your views known to the ASTM Committee on Standards, at the address shown below.

This standard is copyrighted by ASTM International, 100 Barr Harbor Drive, PO Box C700, West Conshohocken, PA 19428-2959, United States. Individual reprints (single or multiple copies) of this standard may be obtained by contacting ASTM at the above address or at 610-832-9585 (phone), 610-832-9555 (fax), or service@astm.org (e-mail); or through the ASTM website (www.astm.org).