



Designation: **C 645 – 034**

Standard Specification for Nonstructural Steel Framing Members¹

This standard is issued under the fixed designation C 645; the number immediately following the designation indicates the year of original adoption or, in the case of revision, the year of last revision. A number in parentheses indicates the year of last reapproval. A superscript epsilon (ϵ) indicates an editorial change since the last revision or reapproval.

This standard has been approved for use by agencies of the Department of Defense.

1. Scope*

1.1 This specification covers nonstructural steel framing members in interior construction assemblies.

1.2 The values stated in inch-pound units are to be regarded as the standard. The SI (metric) values given in parentheses are provided for information purposes only.

1.3 The following safety hazards caveat pertains only to the test methods portion, Sections 9 and 10, of this specification: *This standard does not purport to address all of the safety concerns, if any, associated with its use. It is the responsibility of the user of this standard to establish appropriate safety and health practices and determine the applicability of regulatory limitations prior to use.*

¹ This specification is under the jurisdiction of ASTM Committee C11 on Gypsum and Related Building Materials and Systems and is the direct responsibility of Subcommittee C11.02 on Specifications and Test Methods for Accessories and Related Products.

Current edition approved ~~Aug. 10, 2003~~; Jan. 1, 2004. Published ~~October 2003~~; February 2004. Originally approved in 1970. Last previous edition approved in 2000~~3~~ as C 645 – 00~~3~~.

*A Summary of Changes section appears at the end of this standard.

2. Referenced Documents

2.1 ASTM Standards:²

- A 653/A 653M Specification for Zinc-Coated (Galvanized) or Zinc-Iron Alloy-Coated (Galvanized) by the Hot-Dipped Process
- A 1003/A 1003M Specification for Steel Sheet, Carbon, Metallic- and Nonmetallic-Coated for Cold-Formed Framing Members
- C 11 Terminology Relating to Gypsum and Related Building Materials and Systems
- C 36 Specification for Gypsum Wallboard
- C 1002 Specification for Steel Drill Screws for the Application of Gypsum Board or Metal Plaster Bases

2.2 AISI Standard:

- Specification for the Design of Cold-Formed Steel Structural Members³

3. Terminology

3.1 *Definitions*—Definitions shall be in accordance with Terminology C 11.

3.2 *Definitions of Terms Specific to This Standard:*

3.2.1 *members, n*—in screw application of gypsum board, studs, runners (track), hat furring channels, main beams and cross furring members of grid suspension systems or other items manufactured in accordance with this specification.

3.2.2 *nonstructural wall stud, n*—a member in a steel framed wall system which is limited to a lateral (transverse) load of not more than 10 lb/ft² (480 Pa), a superimposed vertical load, exclusive of sheathing materials, of not more than 100 lbf/ft (1460 N/m), or a superimposed vertical load of not more than 200 lbs (890 N).

4. Materials and Manufacture

4.1 Members shall be manufactured from steel meeting the requirements of Specification A 1003/A 1003M.

4.2 Members shall have a protective coating conforming to Specification A 653/A 653M – G 40 minimum or shall have a protective coating with an equivalent corrosion resistance.

4.3 Members shall be manufactured from steel having a minimum thickness, individual measurement of 0.0179 in. (0.455 mm) before application of protective coating.

5. Dimensions and Permissible Variations

5.1 Studs and rigid furring channels shall have a configuration and steel thickness such that the system in which they are used will carry the design transverse loads without exceeding either the allowable stress of the steel or the allowable design deflection. Main beams and cross furring of grid suspension systems shall be limited to a deflection of L/240. The manufacturer shall supply sufficient data for calculating design performance.

NOTE 1—Allowable deflection varies depending on the cladding used and architectural requirements. Detailed requirements shall be specified in application specifications.

5.1.1 Members, except main beams of grid suspension systems, shall be sufficiently rigid to permit penetration of the screw.

5.1.2 Minimum width of face to which gypsum board is screw-attached shall be not less than 1¼ in. (32 mm).

5.1.3 Minimum lip dimension shall be 3/16 in. (5 mm). See ~~Appendix X1, Fig. X1.1-1.~~

5.2 Members shall be manufactured within the limits as shown in Table 1 and Fig. ~~± 2.~~

5.3 *Rigid Furring Channels*—Minimum depth shall be 7/8 in. (22 mm). Minimum width of furring attachment flanges (see Fig. ~~± 3~~) shall be ½ in. (12.7 mm).

5.4 Grid suspension systems include main beams and cross furring members which mechanically interlock to form a modular supporting network. Length tolerance for grid suspension members shall be ± 1/16 in. (1.59 mm).

5.5 Runners (track) shall be formed in a U-shaped configuration, having web depth compatible with those of the studs of the same nominal size. The runners (track) shall be designed such that when the studs are placed in both the top and bottom runners (track), they are held by friction. Minimum height of flanges shall be 1 in. (25 mm).

6. Edges

6.1 Members shall be manufactured in such a fashion as to minimize burrs and sharp edges.

7. Cutouts

7.1 Cutouts shall not reduce the performance of the members in the gypsum board construction assembly below the specified performance requirements.

8. Sectional Properties

8.1 The sectional properties of members shall be computed in accordance with AISI Specifications for the Design of

² For referenced ASTM standards, visit the ASTM website, www.astm.org, or contact ASTM Customer Service at service@astm.org. For *Annual Book of ASTM Standards* volume information, refer to the standard's Document Summary page on the ASTM website.

³ Available from the American Iron and Steel Institute, 1000 16th St. N.W., Washington, DC 20036.

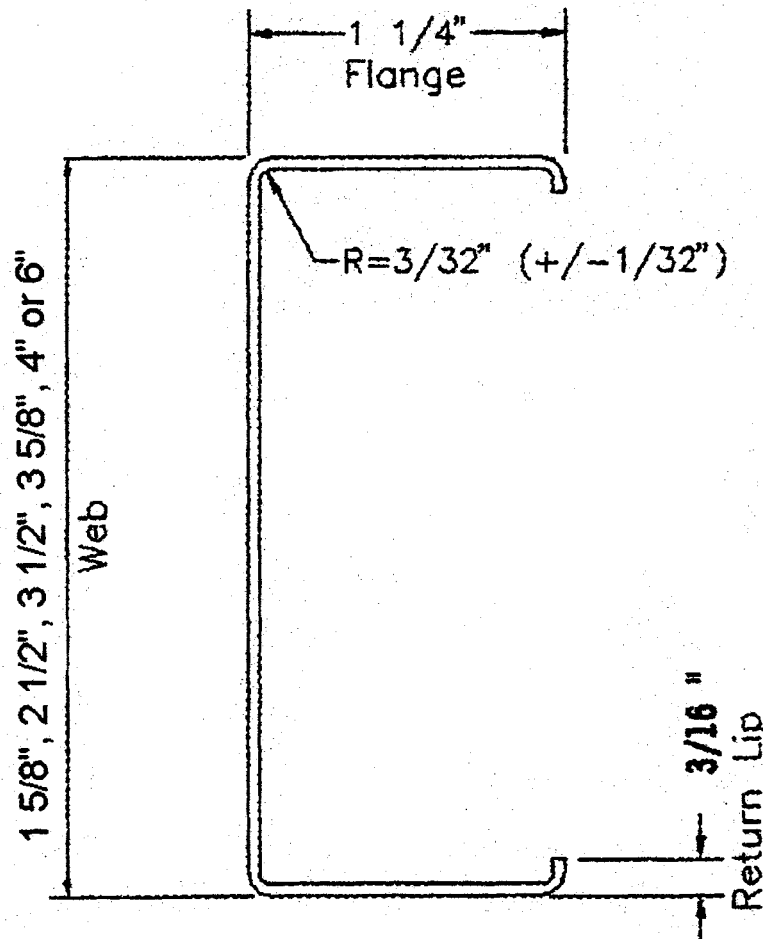

FIG. 1 Minimum Drywall Stud Cross Section

Cold-Formed Steel Structural Members (See Tables 2 and 3 and Appendix X1)-Figs. 1 and 3).

9. Performance Requirements

9.1 *Penetration*—When tested in accordance with Section 10, members shall be capable of pulling the head of the screw below the surface of the gypsum board in less than 2 s without spin out.

10. Penetration Test

10.1 *Significance and Use*—This test method provides a procedure for evaluating the member's ability to pull the head of a screw below the surface of gypsum board. It shall be used to determine compliance with this specification. The degree of performance of this test method with service performance has not been determined.

10.2 *Apparatus shall satisfy the following:*

10.2.1 *Electric Drill*, capable of 2500 r/min (free spindle speed), supplied with a screw driving bit to fit the screw used in the test.

10.2.2 *Stop Watch*, capable of being read to the nearest 0.1 s.

10.3 *Materials shall satisfy the following:*

10.3.1 *Wallboard*—Specification C 36, Type X, 5/8 in. (16 mm) thick.

10.3.2 *Screws*—Specification C 1002, Type S, 1 in. (25.4 mm) long.

10.3.3 *Kraft Paper*—0.010 in. (0.254 mm) thick.

10.4 *Sampling*—One member shall be selected from each bundle or package but not more than ten from any one shipment for testing.

10.5 *Specimen Preparation:*

10.5.1 Each member to be tested shall be cut into test specimens not less than 18 in. (460 mm) long.

10.5.2 For each test, one piece of wallboard, 6 in. (12.7 mm) square, shall be cut from not less than 12 in. (305 mm) from the edge or end of the wallboard.

TABLE 1 Manufacturing Tolerances

Dimension ^A	Item Checked	Drywall Studs, in. (mm)	Drywall Track, in. (mm)
A	length	+ 1/8 (3.18) - 1/4 (6.35)	+ 1 (25.40) - 1/4 (6.35)
A	length	+ 1/8 (3.18) (6.35) 1/4 (6.35)	+ 1 (25.40) - 1/4 (6.35)
B ^B	web width	+ 1/32 (0.79) - 1/32 (0.79)	+ 1/8 (3.18) - 0 (0)
C	flare overbend	+ 1/16 (1.59) - 1/16 (1.59)	+ 0 (0) - 3/16 (4.76)
D	hole center width	+ 1/8 (3.18) - 1/8 (3.18)	NA
E	hole center length	+ 1/4 (6.35) - 1/4 (6.35)	NA
F	erown	+ 1/8 (3.18) - 1/8 (3.18)	+ 1/8 (3.18) - 1/8 (3.18)
F	rown	+ 1/8 (3.18) (3.18) 1/8 (3.18)	+ 1/8 (3.18) - 1/8 (3.18)
G	camber	1/32 per ft (0.79) 1/2 max (12.7)	1/32 per ft (0.79) 1/2 max (12.7)
H	bow	1/32 per ft (0.79) 1/2 max (12.7)	1/32 per ft (0.79) 1/2 max (12.7)
I	twist	1/32 per ft (0.79) 1/2 max (12.7)	1/32 per ft (0.79) 1/2 max (12.7)

^A All measurements shall be taken not less than 1 ft (305 mm) from the end.

^B Outside dimension for stud; inside for track.

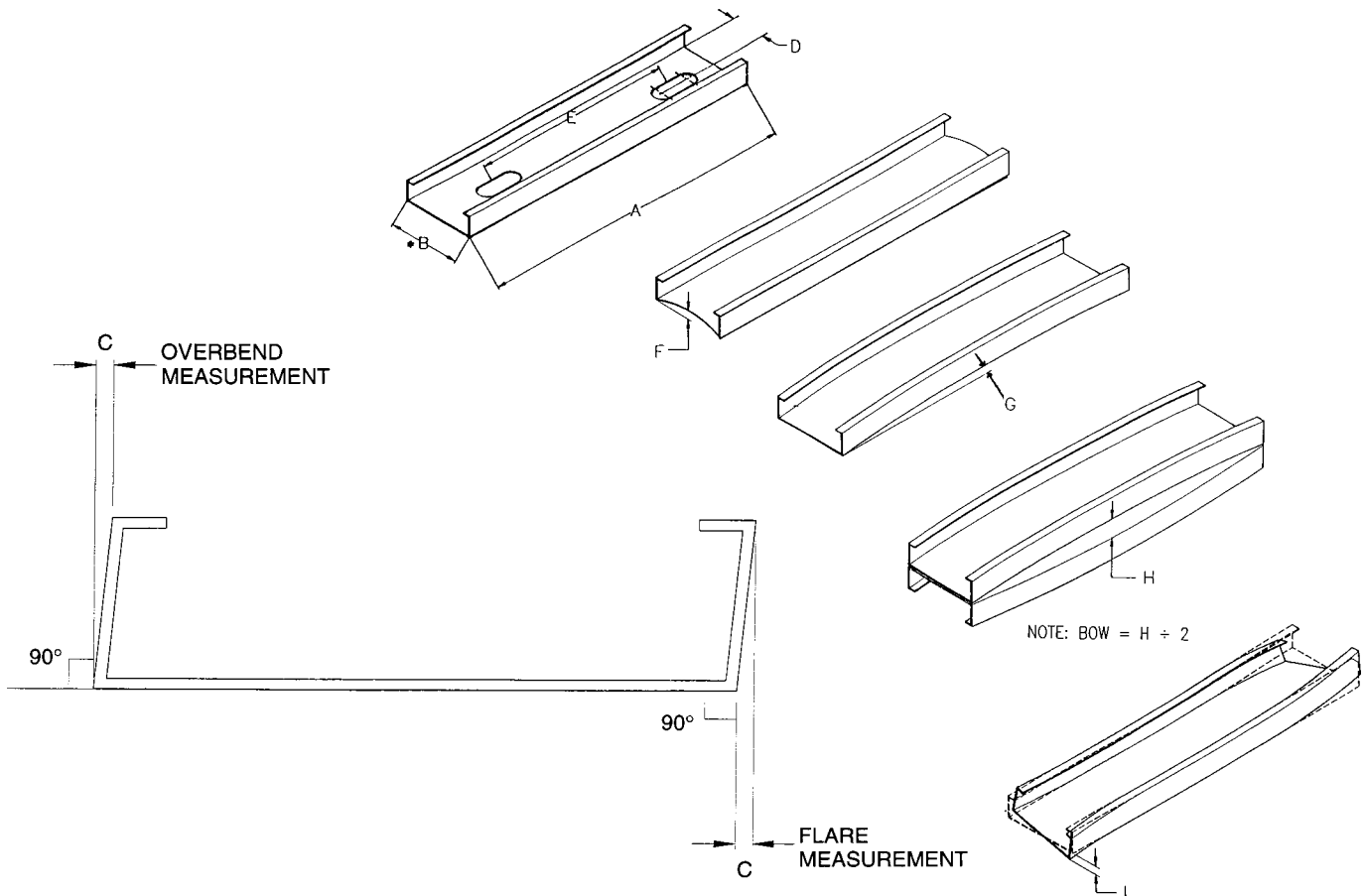

FIG. 1 Manufacturing Tolerances

10.5.3 For each test, four pieces of kraft paper, 2 in. (51 mm) square shall be cut.

10.6 Procedure—Assemble the member, gypsum board and kraft paper on a rigid, flat surface. (See Fig. 3.4 for studs, Fig. 2.5 for furring channels.) Drive the screw, using the electric drill while applying a force (dead weight and applied force) of 25 lbf (112.2 N). Drive the screw to slightly below the surface of the gypsum board. Note if the screw has spun out and the length of time it takes to pull the head of the screw below the surface.

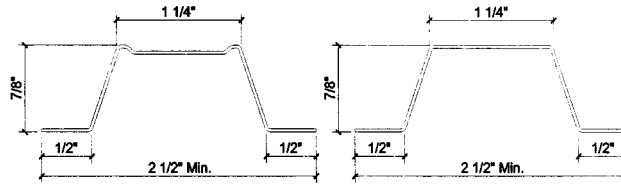

FIG. 3 Hat Furring Channel Cross Section

TABLE 2 Minimum Section Properties for Various Studs

Section Designator ^A	Stud Depth		Design Thickness		Minimum Base Metal Thickness ^B		Area	Effective Properties ^C				
	in. (mm)	in. (mm)	in. (mm)	in. (mm)	in. (mm)	in ² (mm ²)		in ⁴	I _x ^D (1000 mm ⁴)	Ma (in-k)	Ma (N-m)	
162S125-18	1.625	41	0.0188	0.478	0.0179	0.454	0.080	52	0.034	14	0.66	75
162S125-30	1.625	41	0.0312	0.792	0.0296	0.752	0.132	85	0.060	25	1.16	131
162S125-33	1.625	41	0.0346	0.879	0.0329	0.835	0.145	94	0.066	27	1.35	153
250S125-18	2.500	64	0.0188	0.478	0.0179	0.454	0.097	63	0.089	37	1.17	132
250S125-30	2.500	64	0.0312	0.792	0.0296	0.752	0.159	102	0.159	66	2.06	2.33
250S125-33	2.500	64	0.0346	0.879	0.0329	0.835	0.176	114	0.175	73	2.38	269
350S125-18	3.500	89	0.0188	0.478	0.0179	0.454	0.115	74	0.197	82	1.72	194
350S125-30	3.500	89	0.0312	0.792	0.0296	0.752	0.190	123	0.346	144	3.29	372
350S125-33	3.500	89	0.0346	0.879	0.0329	0.835	0.210	135	0.382	159	3.77	426
362S125-18	3.625	92	0.0188	0.478	0.0179	0.454	0.118	76	0.215	89	1.78	201
362S125-30	3.625	92	0.0312	0.792	0.0296	0.752	0.194	125	0.375	156	3.46	391
362S125-33	3.625	92	0.0346	0.879	0.0329	0.835	0.215	138	0.415	173	3.96	448
400S125-18 ^E	4.000	102	0.0188	0.478	0.0179	0.454	0.125	81	0.265	110	1.96	221
400S125-30	4.000	102	0.0312	0.792	0.0296	0.752	0.206	133	0.473	197	3.99	450
400S125-33	4.000	102	0.0346	0.879	0.0329	0.835	0.228	147	0.523	218	4.56	515
600S125-30	6.000	152	0.0312	0.792	0.0296	0.752	0.268	173	1.259	524	6.54	739
600S125-33	6.000	152	0.0346	0.879	0.0329	0.835	0.297	192	1.391	579	8.06	911

^A The section designator defines the cold-formed steel framing member dimensions.

Example: 350S125-18

350 designates the member web depth in 100ths of an inch, 350 = 3.50 in. (88.9 mm)

S designates the type of member, S = Stud

125 designates the member flange width in 100ths of an inch, 125 = 1.25 in. (31.8 mm)

-18 designates the minimum base metal thickness in mils, 18 = 0.0179 in. (0.454 mm)

-30 designates the minimum base metal thickness in mils, 30 = 0.0312 in. (0.792 mm)

-33 designates the minimum base metal thickness in mils, 33 = 0.0329 in. (0.836 mm)

^B Minimum base metal thickness is 95 % of Design Thickness.

^C Effective properties are calculated in accordance with the AISI "Specification for the Design of Cold-Formed Steel Structural Members," 1996 edition and are based on a yield strength, F_y = 33 ksi.

^D Moment of inertia, I_x, given is for deflection calculations.

^E Where noted, member web height-to-thickness ratio exceeds 200, web stiffeners required at supports.

TABLE 3 Hat Furring Channel Section Properties

Design Thickness		Minimum Base Metal Thickness ^A		Gross Area		Effective Properties ^B				
in	(mm)	in	(mm)	in ²	(mm ²)	in ^D	I _x ^C (mm ^D)	Ft-Lb	Ma	(N-m)
0.0188	0.477	0.0179	0.453	0.0702	45.29	0.0086	3563	26.4	35.79	
0.0283	0.719	0.0269	0.683	0.1046	67.48	0.0131	5440	44.8	60.74	
0.0312	0.792	0.0296	0.752	0.1184	76.39	0.0144	6010	50.3	68.19	
0.0346	0.879	0.0329	0.835	0.1270	81.94	0.0157	6531	55.4	75.11	

^A Minimum base metal thickness is 95 % of Design Thickness.

^B Effective properties are given as the minimum value for either positive or negative bending.

^C Moment of inertia given is for deflection calculations.

^D Effective properties based on F_y = 33 ksi (227 MPa).

10.7 Number of Tests and Retests :

10.7.1 Five specimens of members shall be tested.

10.7.2 If more than one test specimen fails to meet the requirements, two more test specimens shall be chosen for retesting.

10.8 Report—Report shall indicate all specimens meeting the requirements of this specification if the time read from the stop watch is less than the time specified in Section 9, and the screw did not spin out; or shall indicate all failing if the time read is equal to or longer than the time specified in Section 9, or the screw spun out.

10.9 Precision and Bias—No statement is made about either the precision or bias of this test method since the result merely

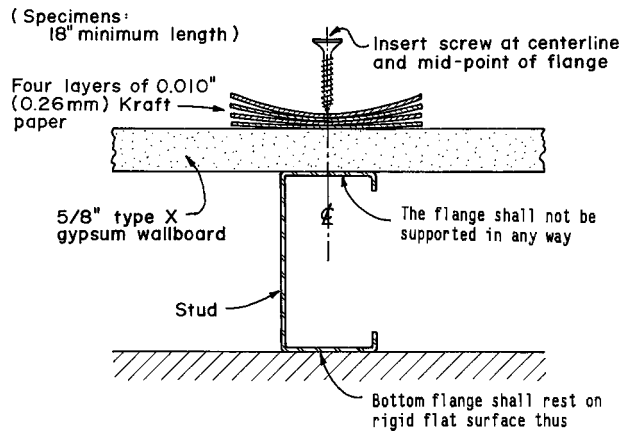
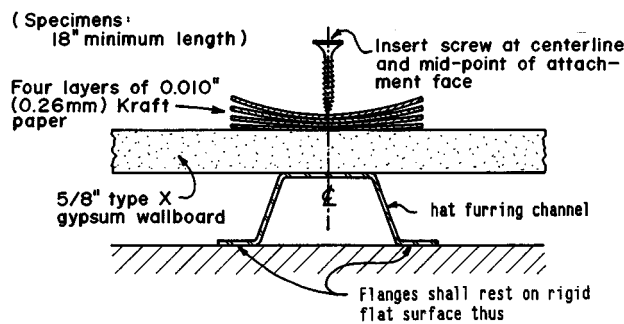

FIG. 3 4 Studs



NOTE 1—Wallboard specimens shall be taken a minimum of 12 in. (305 mm) from either edge and either end of wallboard panel.

FIG. 2 5 Hat Furring Channels

states whether or not there is conformance to the criteria for success specified in the procedure.

11. Inspection

11.1 Inspection of the members shall be agreed upon between the purchaser and the producer or supplier as part of the purchase agreement.

12. Rejection

12.1 When specified in the purchase agreement, members that fail to conform to the requirements of the specification shall be rejected. Rejection shall be reported to the producer or supplier promptly and in writing. The notice of rejection shall contain a statement documenting how the member has failed to conform to the requirements of this specification and the purchase agreement.

13. Certification

13.1 When specified in the purchase agreement, a producer's or supplier's report shall be furnished at the time of shipment certifying that the product is in compliance with this specification.

14. Marking and Identification

14.1 Groups of like members shall be marked with a label, or a tag attached thereto. Marking shall include length, quantity and rollformer's member designator including member depth, flange size, and minimum steel thickness in mils or inches, exclusive of protective coating.

14.2 In addition to the marking referenced in 14.1, individual members shall have a legible label, stencil, or embossment, at a maximum distance of 48 in. (1220 mm) on center, on the web of the member, with the following minimum information:

- 14.2.1 The rollformer's identification (that is, name, logo or initials).
- 14.2.2 The minimum steel thickness, in mils or inches, exclusive of protective coating.
- 14.2.3 The minimum yield strength in ksi (MPa) if other than 33 ksi (230 MPa).
- 14.2.4 The minimum protective coating weight, G-XX, if other than as specified in Section 4.

15. Keywords

15.1 furring channels; grid suspension systems; gypsum board; runners; screws; section properties; spinout; studs

APPENDIXES

(Nonmandatory Information)

~~X1. MINIMUM DRYWALL STUD CROSS SECTION~~

~~X2. HAT FURRING CHANNEL CROSS SECTION~~

~~X3. COLOR~~

APPENDIX

X1. COLOR CODING FOR MEMBERS

X31.1 Color code individual members or bundles of like members in accordance with Table X31.1.

TABLE X31.1 Color Codes for Members

NOTE 1—Minimum base metal thickness is 95 % of the design thickness.

Color	Minimum Base Metal Thickness, mils	Minimal Decimal Equivalent,	
		in.	(mm)
None	18	0.0179	(0.4550)
Black	27	0.0269	(0.683)
Pink	30	0.0296	(0.752)
White	33	0.0329	(0.836)

SUMMARY OF CHANGES

Committee C11 has identified the location of selected changes to this specification since the last issue, C 645 - 003, that may impact the use of this standard specification. (Approved ~~August 10, 2003~~; January 1, 2004)

- ~~(1) Revised Table 2 to include 3.625 in. studs, 30 mil studs;~~ (1) Deleted Appendix X1 and Appendix X2 to be in accordance with move hat-furring channel properties and figures from the most current edition Appendix into the body of the AISI Specification.
- ~~(2) Revised paragraph 4.1.2)~~ Renumbered Appendix X3 as X1.
- ~~(3) Removed 0.0320 hat-furring channel properties from Table 3.~~
- ~~(3) Removed the thickness “t” and included 6” studs in Fig. 1.~~

Committee C11 has identified the location of selected changes to this specification since the last issue, C 645 - 9900, that may impact the use of this ~~standard~~ specification. (Approved ~~January~~ August 10, 2000; 2003)

- ~~(1) A Revised Table 2 to include 3.625 in. studs, 30 mil studs, and to be in accordance with the most current edition of the AISI Specification 14.~~
- ~~(2) Added new Appendix X3.~~
- ~~(3) Revised paragraph 7.1.~~
- ~~(4) Revised paragraph 14.1.~~
- ~~(5) Added Table X3.1. 4.1.~~

ASTM International takes no position respecting the validity of any patent rights asserted in connection with any item mentioned in this standard. Users of this standard are expressly advised that determination of the validity of any such patent rights, and the risk of infringement of such rights, are entirely their own responsibility.

This standard is subject to revision at any time by the responsible technical committee and must be reviewed every five years and if not revised, either reapproved or withdrawn. Your comments are invited either for revision of this standard or for additional standards and should be addressed to ASTM International Headquarters. Your comments will receive careful consideration at a meeting of the responsible technical committee, which you may attend. If you feel that your comments have not received a fair hearing you should make your views known to the ASTM Committee on Standards, at the address shown below.

This standard is copyrighted by ASTM International, 100 Barr Harbor Drive, PO Box C700, West Conshohocken, PA 19428-2959, United States. Individual reprints (single or multiple copies) of this standard may be obtained by contacting ASTM at the above address or at 610-832-9585 (phone), 610-832-9555 (fax), or service@astm.org (e-mail); or through the ASTM website (www.astm.org).