



**Designation: C 754 – 99a00**

## **Standard Specification for Installation of Steel Framing Members to Receive Screw- Attached Gypsum Panel Products<sup>1</sup>**

This standard is issued under the fixed designation C 754; the number immediately following the designation indicates the year of original adoption or, in the case of revision, the year of last revision. A number in parentheses indicates the year of last reapproval. A superscript epsilon ( $\epsilon$ ) indicates an editorial change since the last revision or reapproval.

*This standard has been approved for use by agencies of the Department of Defense.*

### **1. Scope\***

1.1 This specification covers the minimum requirements for the installation of interior nonstructural steel framing and furring members designed to receive screw-attached gypsum panel products. The steel framing and furring members covered in this specification are limited to those complying with Specification C 645.

1.2 Details of construction for a specific assembly to achieve the required fire resistance shall be obtained from reports of fire-resistance tests, engineering evaluations, or listings from recognized fire testing laboratories.

1.3 The values stated in inch-pound units are to be regarded as the standard. The SI (metric) values given in parentheses are approximate and are provided for information purposes only.

### **2. Referenced Documents**

#### *2.1 ASTM Standards:*

A 366/A 366M Specification for Commercial Steel (CS), Sheet, Carbon, (0.15 Maximum Percent) Cold-Rolled <sup>2</sup>

<sup>1</sup> This specification is under the jurisdiction of ASTM Committee C-11 on Gypsum and Related Building Materials and Systems and is the direct responsibility of Subcommittee C11.03 on Specifications for Application of Gypsum and Other Products in Assemblies.

Current edition approved Oct. 10, 1999; 2000. Published January 2000<sup>1</sup>. Originally published as C 754 – 74. Last previous edition C 754 – 99a.

**\*A Summary of Changes section appears at the end of this standard.**

A 641/A 641M Specification for Zinc-Coated (Galvanized) Carbon Steel Wire<sup>3</sup>

A 653/A 653M Specification for Steel Sheet, Zinc-Coated (Galvanized) or Zinc-Iron Alloy-Coated (Galvannealed) by the Hot-Dip Process<sup>3</sup>

C 11 Terminology Relating to Gypsum and Related Building Materials and Systems<sup>4</sup>

C 645 Specification for ~~Nonstructural Non-Load Bearing (Axial) Steel Framing Members~~ Studs, Runners, (Tracks), and Rigid Furring Channels for Screw Application of Gypsum Board<sup>4</sup>

### 3. Terminology

3.1 *Definitions*—Terms shall be as defined in Terminology C 11.

3.2 *Descriptions of Terms Specific to This Standard:*

3.2.1 *channel, n*—the material described in 4.3 to which furring members are attached.

3.2.2 *cross furring, n*—furring member attached perpendicular to main runners or framing members.

3.2.3 *cross furring member, n*—a member installed perpendicularly to the main beams designed to receive screw attached gypsum panel products.

3.2.4 *direct furring, n*—furring members attached directly to the structural members of the building.

3.2.5 *framing member, n*—metal studs, runners (track), and rigid furring channels designed to receive screw attached gypsum panel products.

3.2.6 *furred ceiling, n*—a ceiling in which the rigid furring channels and studs are attached directly to the structural members of the building.

3.2.7 *furring, v*—preparing a wall or ceiling with framing or furring members to provide a level surface or airspace.

3.2.8 *furring member, n*—metal studs, rigid furring channels, or channels used either as direct furring or as cross furring.

3.2.9 *grid suspension system, n*—a ceiling system composed of modular interlocking steel components designed to receive screw-attached gypsum panel products.

3.2.10 *main beam, n*—the main support member of a grid suspension system that receives cross furring members.

3.2.11 *main runner, n*—the channel or stud that is attached to or suspended from the structural members of the building.

3.2.12 *runner (track), n*—a member designed to receive the ends of metal studs, attached directly to the structural members of the building.

3.2.13 *suspended ceiling, n*—a ceiling in which the main runners and cross furring are suspended below the structural members of the building.

### 4. Materials and Manufacture

4.1 *Studs, Runners, Rigid Furring Channels, and Grid Suspension Systems*—see Specification C 645.

4.2 *Tie Wire and Hanger Wire*—Zinc-coated (galvanized) soft-annealed steel, or of a material and size having equivalent corrosion resistance and strength. Wire diameters (uncoated) specified herein correspond with United States steel wire gage numbers as follows:

Diameter, <sup>A</sup>		Wire Gage
in.	mm	(U.S. Steel Wire Gage)
0.0348	0.88	No. 20
0.0410	1.04	No. 19
0.0475	1.21	No. 18
0.0540	1.37	No. 17
0.0625	1.59	No. 16
0.0800	2.03	No. 14
0.0915	2.32	No. 13
0.1055	2.68	No. 12
0.1205	3.06	No. 11
0.1350	3.43	No. 10
0.1483	3.77	No. 9
0.1620	4.12	No. 8

<sup>A</sup> Allowable variations in diameter shall be in accordance with tolerances as established in A 641/A 641M.

4.3 *Channels*—Channels shall be cold-formed from steel with a minimum 33 000 psi (228 MPa) yield strength and 0.0538 in. (1.37 mm) minimum bare steel thickness. Channels shall have a protective coating conforming to Specification A 653/A 653–G 40 or shall have a protective coating with an equivalent corrosion resistance, and shall have the following minimum weights in lb per 1000 linear ft (kg/m):

Size,		Weight	Flange Width	
in.	(mm)	lb/1000 ft	in.	(mm)
¾	(19)	277	½	(13)
1½	(38)	414	½	(13)

<sup>2</sup> Annual Book of ASTM Standards, Vol 01.03.

<sup>3</sup> Annual Book of ASTM Standards, Vol 01.06.

<sup>4</sup> Annual Book of ASTM Standards, Vol 04.01.

2	(51)	506	(0.753)	½	(13)
2½	(64)	597	(0.888)	½	(13)

4.4 *Grid Suspension System:*

4.4.1 *Main Beam*—Formed from cold-rolled steel “T” sections, indexed with slots to receive ends of cross furring members, and with stamped couplings at each end for the purpose of splicing.

4.4.2 *Cross Furring Members*—Formed from cold-rolled steel, designed to permit screw attachment of gypsum panel products, and formed with an end configuration that permits mechanical interlock with the indexed slots of the main beam.

4.5 *Rod and Flat Hangers*—Formed from steel conforming to Specification A 366/A 366M. When specified, rod and flat hangers shall be protected with zinc coating or another equally rust-inhibiting coating.

**5. Installation of Metal Framing**

5.1 *Tolerances:*

5.1.1 Spacing of studs and furring members shall be not more than ± 1/8 in. (3 mm) from the spacing shown in Tables 1 and 2. Any cumulative error shall be not more than ± 1/8 in.

5.2 *Runner (Track) Installation:*

5.2.1 *General*—Runners shall be aligned accurately at the floor and ceiling and securely anchored approximately 2 in. (50 mm) from the runner ends, not more than 24 in. (610 mm) on center. Runners shall be secured with fasteners at partition corners. One runner shall extend to the end of the corner and the other runner shall butt to it and be gapped to allow clearance for the gypsum panel product thickness. Runners shall not be mitered.

5.2.2 *Runners to Concrete Slabs*—Shall be fastened with concrete stub nails, expansion anchors, shielded screws, or power-driven fasteners not exceeding 24 in. (610 mm) on center.

5.2.3 *Runners to Wood*—Shall be fastened with screws providing not less than 1 in. (25 mm) penetration or nails providing 1½ in. (38 mm) penetration into the wood.

5.2.4 *Runners to Suspended Ceilings*—Shall be fastened with “Molly”-type expandable fasteners, toggle bolts, clamps, or screws into channels, splines, “T” runners, or other members.

5.3 *Stud Installation:*

5.3.1 *Stud Height and Spacing Limitations:*

**TABLE 1 Maximum Framing Spacing**

NOTE—Where a conflict exists in spacing between base and face layers, the closer spacing shall govern.

Gypsum Panel Product Thickness		Location	Application	Maximum Spacing, oc		
Base Layer, in. (mm)	Face Layer, in. (mm)			One Layer Only, in. (mm)	Two Layers	
				Fasteners Only, in. (mm)	Adhesive Between Layers, in. (mm)	
¾ (9.5)	...	ceilings	perpendicular	16 (406) <sup>A</sup>	16 (406) <sup>A</sup>	16 (406) <sup>A</sup>
	¾ (9.5)	ceilings	perpendicular	NA	16 (406)	16 (406)
	¾ (9.5)	ceilings	parallel	NA	NR	16 (406)
½ (12.7)	...	ceilings	perpendicular	24 (610) <sup>A</sup>	24 (610) <sup>A</sup>	24 (610) <sup>A</sup>
	...	ceilings	parallel	16 (406) <sup>A</sup>	16 (406) <sup>A</sup>	16 (406) <sup>A</sup>
	¾ (9.5)	ceilings	perpendicular	NA	16 (406)	24 (610)
	¾ (9.5)	ceilings	parallel	NA	NR	24 (610)
	½ (12.7)	ceilings	perpendicular	NA	24 (610)	24 (610)
	½ (12.7)	ceilings	parallel	NA	16 (406)	24 (610)
⅝ (15.9)	...	ceilings	perpendicular	24 (610) <sup>A</sup>	24 (610) <sup>A</sup>	24 (610) <sup>A</sup>
	...	ceilings	parallel	16 (406) <sup>A</sup>	16 (406) <sup>A</sup>	16 (406) <sup>A</sup>
	¾ (9.5)	ceilings	perpendicular	NA	16 (406)	24 (406)
	¾ (9.5)	ceilings	parallel	NA	NR	24 (610)
	½ or ⅝ (12.7 or 15.9)	ceilings	perpendicular	NA	24 (610)	24 (610)
	½ or ⅝ (12.7 or 15.9)	ceilings	parallel	NA	16 (406)	24 (406)
	¾ (9.5)	ceilings	parallel	NA	16 (406) <sup>A</sup>	16 (406) <sup>A</sup>
¼ (6.4)	...	walls	parallel	NR	16 (406) <sup>A</sup>	16 (406) <sup>A</sup>
	¾ (9.5)	walls	NR	NR	NR	NR
	½ or ⅝ (12.7 or 15.9)	walls	perpendicular or parallel	NA	16 (406)	16 (406)
⅙ (9.5)	...	walls	perpendicular or parallel	16 (406) <sup>A</sup>	16 (406) <sup>A</sup>	24 (610) <sup>A</sup>
	⅙ or ½ or ⅝ (9.5 or 12.7 or 15.9)	walls	perpendicular or parallel	NA	16 (406)	24 (610)
	...	walls	perpendicular or parallel	24 (610) <sup>A</sup>	24 (610) <sup>A</sup>	24 (610) <sup>A</sup>
½ or ⅝ (12.7 or 15.9)	...	walls	perpendicular or parallel	24 (610) <sup>A</sup>	24 (610) <sup>A</sup>	24 (610) <sup>A</sup>
	⅙ or ½ or ⅝ (9.5 or 12.7 or 15.9)	walls	perpendicular or parallel	NA	24 (610)	24 (610)

Perpendicular—perpendicular to framing members

Parallel—parallel to framing members

NA—not applicable

NR—not recommended

oc—on center

<sup>A</sup> Denotes framing spacing for base layer in two-layer application.

**TABLE 2 Spans and Spacings of Horizontal Furring Members**

Type of Furring	Maximum <sup>A</sup> Spacing c to c, <sup>B</sup> in. (mm)	Maximum Span, ft (mm)
Rigid Furring Channel	24 (610)	4 (1220)
<del>4½ in. (41 mm) stud</del> (erected with open side up and against support)	<del>24 (610)</del>	<del>5 (1520)</del>
1½ in. (41 mm) stud (erected with open side up and against support)	24 (610)	5 (1520)
2½ in. (64 mm) stud (erected with web vertical to support) <sup>C</sup>	24 (610)	6 (1830)
3½ in. (92 mm) stud (erected with web vertical to support) <sup>C</sup>	24 (610)	8 (2440)

<sup>A</sup> Consult Table 1 for maximum spacing as determined by gypsum panel product thickness.

<sup>B</sup> c to c—center to center

<sup>C</sup> A 6 in. (150 mm) length of same size stud or track shall be nested to form a “box” at each saddle tie.

5.3.1.1 Maximum framing spacing determined by gypsum panel product thickness shall be in accordance with Table 1.

5.3.1.2 Stud heights shall be not greater than those shown in Tables 3 and 4.

5.3.1.3 Studs shall engage both the floor and ceiling runners. The gap between the end of a stud and the web of the top and bottom runner shall be not more than ¼ in. (6 mm).

5.3.1.4 Where conditions require that a partition be constructed with compensation for vertical structural movement, the gap between the end of a stud and the adjacent runner shall be designed by an architect or engineer.

#### 5.3.2 Location:

5.3.2.1 Studs shall be positioned vertically and shall be spaced not more than the maximum framing spacing allowed for the finish specified. Studs located adjacent to door and window frames, partition intersections, and corners shall be anchored to runner flanges by screws, or by crimping at each stud and runner flange.

5.3.2.2 At the junction of through and abutting partitions, a stud shall be located not more than 2 in. (50 mm) away from the intersection in the abutting partition from the through partition (see Fig. 1), and not more than 2 in. (50 mm) from partition corners and other construction. A stud shall be located adjacent to all door and borrowed light frames. Studs shall be securely anchored to the jamb anchor clips on each door frame or borrowed light frame by bolt or screw attachment. A header shall be formed over metal door and borrowed light frames with a cut-to-length section of runner placed horizontally with the flanges cut and web bent vertically at each end, and securely attached to the adjacent vertical studs. A cut-to-length stud shall be positioned at the location of vertical joints over the header extending to the ceiling runner. Additional cut to length studs required to comply with framing spacing in accordance with Table 1 shall also be added over the header, extending to the ceiling runner.

5.3.2.3 At partition corners, a stud shall be installed so that it forms the outside corner. Following application of a single layer of gypsum panel product to this stud, a second stud shall be installed in the abutting runner and the web shall be screw attached through the gypsum panel product into the flange of the first stud (see Fig. 2). A three-stud conventional corner shall be permitted (see Fig. 3).

#### 5.4 Chase Wall Partitions:

5.4.1 A double row of runners and studs as specified in 5.2 and 5.3 shall be installed. Height shall be in accordance with 5.3.1.2.

5.4.2 Where a gypsum panel product is used as bracing between chase walls, a gap of not more than 20 in. (508 mm) between rows of studs shall be permitted.

5.4.3 Horizontal cross braces to opposite studs shall be installed not more than 4 ft (1220 mm) on center vertically. Horizontal cross braces shall be either of the following:

5.4.3.1 Gypsum panel product gussets 12 in. (305 mm) deep attached to the stud webs with three screws.

5.4.3.2 A stud or runner with the web screw attached to the wall stud web with not less than two screws.

5.5 *Rigid Furring Channel Installation, Direct Attachment to Masonry or Concrete*—The furring member shall be attached to masonry or concrete surfaces, either vertically or horizontally. Spacing shall be determined by gypsum panel product thickness in accordance with Table 1. For furring positioned horizontally, the center line of the furring members closest to the floor and ceiling shall be attached not more than 3 in. (76 mm) from the floor and ceiling lines. The furring member shall be secured with fasteners occurring on alternated flanges and spaced 24 in. (610 mm) on center.

#### 5.6 Wall Furring-Bracket System:

5.6.1 Adjustable wall furring brackets with serrated edges facing upward shall be attached to masonry or concrete walls in the following spacing pattern: 48 in. (1220 mm) on center vertically, 6 in. (152 mm) maximum from floor and ceiling, 36 in. (910 mm)

**TABLE 3 Maximum Stud Height<sup>A</sup>, ft.-in. (mm), Single Layer ½-in. (12.7-mm) Thick Gypsum Board<sup>B</sup> on Each Side of Minimum 0.0179-in. (0.455-mm) Base Metal Thickness Steel Studs Spaced 12-in. (305-mm), 16-in. (406-mm), and 24-in. (610-mm) o.c.<sup>C,D</sup>**

Stud Depth, in. (mm) Industry Designator <sup>E</sup>	Deflection Limit	Maximum Stud Height									
		ft.-in. (mm)					ft.-in. (mm)				
		Stud Depth, in. (mm), Industry Designator <sup>D</sup>	Deflection Limit	Framing Spaced 12 in. (305 mm) o.c. Lateral Pressure			Framing Spaced 16 in. (406 mm) o.c. Lateral Pressure			Framing Spaced 24 in. (610 mm) o.c. Lateral Pressure	
5 psf (240 Pa)	7.5 psf (360 Pa)	10 psf (480 Pa)	5 psf (240 Pa)	7.5 psf (360 Pa)	10 psf (480 Pa)	5 psf (240 Pa)	7.5 psf (360 Pa)	10 psf (480 Pa)	40 psf (480 Pa)		
1-5/8 (41.3)	L120	9-9 (2970)	8-0 (2440)	8-10 (2690)	10-7 (3230)	8-10 (2690)	8-4 (2540)	9-9 (2970)	8-0 (2440)		<sup>E</sup>
	1-5/8 (41.3)	162S125-18	L240	9-9 (2970)	8-10 (2690)	8-4 (2540)	8-10 (2690)	8-4 (2540)	9-9 (2970)	8-0 (2440)	<sup>E</sup>
	L240	8-10 (2690)	<sup>E</sup>	<sup>E</sup>	8-4 (2540)	<sup>E</sup>	<sup>E</sup>	7-11 (2410)	<sup>E</sup>	<sup>E</sup>	<sup>E</sup>
L360	<sup>E</sup>	<sup>E</sup>	<sup>E</sup>	<sup>E</sup>	<sup>E</sup>	<sup>E</sup>	<sup>E</sup>	<sup>E</sup>	<sup>E</sup>	<sup>E</sup>	<sup>E</sup>
	<sup>E</sup>	<sup>E</sup>	<sup>E</sup>	<sup>E</sup>	<sup>E</sup>	<sup>E</sup>	<sup>E</sup>	<sup>E</sup>	<sup>E</sup>	<sup>E</sup>	<sup>E</sup>
	<sup>E</sup>	<sup>E</sup>	<sup>E</sup>	<sup>E</sup>	<sup>E</sup>	<sup>E</sup>	<sup>E</sup>	<sup>E</sup>	<sup>E</sup>	<sup>E</sup>	<sup>E</sup>
2-1/2 (63.5)	L120	11-10 (3610)	9-8 (2950)	8-5 (2570)	10-9 (3280)	L240	10-7 (3230)	9-3 (2820)	8 (2950)	8-5 (2570)	
	2-1/2 (63.5)	L120	15-1 (4600)	12-4 (3760)	10-9 (3280)	13-3 (4040)	10-10 (3300)	9-5 (2870)	11-10 (3610)	9-8 (2950)	8-5 (2570)
	L240	11-11 (3630)	10-5 (3180)	9-6 (2900)	11-3 (3430)	9-10 (3000)	8-11 (2720)	10-7 (3230)	9-3 (2820)	8-5 (2570)	8-5 (2570)
L360	9-3 (2820)	8-1 (2460)	<sup>E</sup>	9-10 (3000)	8-7 (2620)	<sup>E</sup>	9-3 (2820)	8-1 (2460)	<sup>E</sup>	<sup>E</sup>	<sup>E</sup>
	L360	10-5 (3180)	9-1 (2770)	<sup>E</sup>	9-10 (3000)	8-7 (2620)	<sup>E</sup>	9-3 (2820)	8-1 (2460)	<sup>E</sup>	<sup>E</sup>
	<sup>E</sup>	<sup>E</sup>	<sup>E</sup>	<sup>E</sup>	<sup>E</sup>	<sup>E</sup>	<sup>E</sup>	<sup>E</sup>	<sup>E</sup>	<sup>E</sup>	<sup>E</sup>
3-1/2 (88.9) <sup>Ⓔ</sup>	L120	13-9 (4190)	11-0 (3350)	9-5 (2870)	10-9 (3280)	L240	13-5 (4090)	11-0 (3350)	11-0 (3350)	9-5 (2870)	
	3-1/2 (88.9) <sup>F</sup>	L120	17-8 (5380)	14-3 (4340)	12-5 (3780)	15-4 (4670)	12-5 (3780)	10-9 (3280)	13-9 (4190)	11-0 (3350)	9-5 (2870)
	L240	15-4 (4670)	13-3 (4040)	12-0 (3660)	14-4 (4370)	12-5 (3780)	10-9 (3280)	13-5 (4090)	11-0 (3350)	9-5 (2870)	9-5 (2870)
L360	11-7 (3530)	10-1 (3070)	10-5 (3180)	12-4 (3760)	10-10 (3300)	9-9 (2970)	11-7 (3530)	10-1 (3070)	9-1 (2770)	<sup>E</sup>	<sup>E</sup>
	L360	13-3 (4040)	11-7 (3530)	10-5 (3180)	12-4 (3760)	10-10 (3300)	9-9 (2970)	11-7 (3530)	10-1 (3070)	9-1 (2770)	<sup>E</sup>
	<sup>E</sup>	<sup>E</sup>	<sup>E</sup>	<sup>E</sup>	<sup>E</sup>	<sup>E</sup>	<sup>E</sup>	<sup>E</sup>	<sup>E</sup>	<sup>E</sup>	<sup>E</sup>
4 (101.6)	L120	15-1 (4600)	12-1 (3680)	10-5 (3180)	13-8 (4170)	L240	14-2 (4320)	12-1 (3680)	40	10-5 (3180)	
	4 (101.6)	L120	19-6 (5940)	15-9 (4800)	13-8 (4170)	17-2 (5230)	13-10 (4220)	11-11 (3630)	15-1 (4600)	12-1 (3680)	10-5 (3180)
	L240	16-5 (5000)	14-4 (4370)	13-0 (3960)	15-4 (4670)	13-4 (4060)	11-11 (3630)	14-2 (4320)	12-1 (3680)	10-5 (3180)	10-5 (3180)
L360	12-4 (3760)	10-9 (3280)	11-4 (3450)	13-4 (4060)	11-8 (3560)	10-6 (3200)	12-4 (3760)	10-9 (3280)	9-9 (2970)	<sup>E</sup>	<sup>E</sup>
	L360	14-4 (4370)	12-6 (3810)	11-4 (3450)	13-4 (4060)	11-8 (3560)	10-6 (3200)	12-4 (3760)	10-9 (3280)	9-9 (2970)	<sup>E</sup>
	<sup>E</sup>	<sup>E</sup>	<sup>E</sup>	<sup>E</sup>	<sup>E</sup>	<sup>E</sup>	<sup>E</sup>	<sup>E</sup>	<sup>E</sup>	<sup>E</sup>	<sup>E</sup>
6 (152.4)	L120	16-9 (5110)	13-5 (4090)	11-5 (3480)	16-2 (4930)	L240	16-9 (5110)	13-5 (4090)	13-5 (4090)	11-5 (3480)	
	6 (152.4)	L120	22-10 (6960)	18-7 (5660)	16-2 (4930)	19-9 (6020)	16-2 (4930)	14-0 (4270)	16-9 (5110)	13-5 (4090)	11-5 (3480)
	L240	22-1 (6730)	18-7 (5660)	16-2 (4930)	19-9 (6020)	16-2 (4930)	14-0 (4270)	16-9 (5110)	13-5 (4090)	11-5 (3480)	11-5 (3480)
L360	16-9 (5110)	13-5 (4090)	15-0 (4570)	17-11 (5460)	15-7 (4750)	13-10 (4220)	16-9 (5110)	13-5 (4090)	11-5 (3480)	<sup>E</sup>	<sup>E</sup>
	L360	19-4 (5890)	16-9 (5110)	15-0 (4570)	17-11 (5460)	15-7 (4750)	13-10 (4220)	16-9 (5110)	13-5 (4090)	11-5 (3480)	<sup>E</sup>
	<sup>E</sup>	<sup>E</sup>	<sup>E</sup>	<sup>E</sup>	<sup>E</sup>	<sup>E</sup>	<sup>E</sup>	<sup>E</sup>	<sup>E</sup>	<sup>E</sup>	<sup>E</sup>

<sup>A</sup> Based on tests conducted with gypsum board attached with screws spaced 12 in. (305 mm) o.c. to framing members.

<sup>B</sup> Maximum stud heights also are applicable to walls sheathed with gypsum board greater than ½ in. (12.7 mm) thick and multiple layers of gypsum board.

<sup>C</sup> Maximum stud heights also are applicable to walls with studs spaced less than 24 in. (610 mm) o.c.

<sup>D</sup> Runner flanges need not be fastened to studs except as required by 5.3.2.1.

<sup>E</sup> The *Industry Designator* defines the cold formed steel framing member.

Example: 350S125-18;

350 designates the member web depth in 100ths of an inch, 350 = 3.50 in. (88.9 mm).

S designates the type of member, S = stud.

125 designates the member flange width in 100ths of an inch, 125 = 1.25 in. (32 mm).

18 designates the member base metal thickness in mils, 18 = .0179 in. (0.455 mm).

<sup>F</sup> Data not available.

<sup>Ⓔ</sup> Also applicable to 3-5/8 in. (92.1 mm) stud depth, 362S125-18.

on center horizontally, 4 in. (100 mm) maximum from columns or other abutting construction, and as required above and below windows. Each bracket shall be fastened through the hole nearest to the serrated edges.

5.6.2 Channels ¾ in. (19 mm) shall be laid horizontally on the furring brackets so that the channel flanges engage the serrated edges of the bracket. Each channel shall be plumbed to align with ceiling and base channels. Channels shall be wire-tied to each bracket with a double strand of 16 gage or a triple strand of 18-gage tie wire. Each excess bracket length shall be bent down and inward toward the wall.

5.6.3 Rigid furring channels shall be positioned vertically with wing flanges against the channels with spacing determined by gypsum panel product thickness in accordance with Table 1. Each furring channel intersection shall be wire-tied with a double strand of 16-gage or a triple strand of 18-gage tie wire.

5.7 *Soffits*—Soffits shall be framed by attaching runners to ceilings and walls as specified in 5.2.1. Runners shall be used for backing of all outside corners. Hangers or spacers (cut-to-length pieces of stud), shall be provided from ceiling runner to outside



**TABLE 4 Maximum Stud Height<sup>A</sup>, ft.-in. (mm), Single Layer ½-in. (12.7-mm) Thick Gypsum Board<sup>B</sup> on Each Side of Minimum 0.0329-in. (0.836-mm) Base Metal Thickness Steel Studs Spaced 12-in. (305-mm), 16-in. (406-mm), and 24-in. (610-mm) o.c.<sup>C,D</sup>**

Stud Depth, in. (mm) Industry Designator <sup>E</sup>	Deflection Limit	Maximum Stud Height										
		ft.-in. (mm)					ft.-in. (mm)					
		Stud Depth, in. (mm), Industry Designator <sup>D</sup>	Deflection Limit	Framing Spaced 12 in. (305 mm) o.c. Lateral Pressure			Framing Spaced 16 in. (406 mm) o.c. Lateral Pressure			Framing Spaced 24 in. (610 mm) o.c. Lateral Pressure		
5 psf (240 Pa)	7.5 psf (360 Pa)	10 psf (480 Pa)	5 psf (240 Pa)	7.5 psf (360 Pa)	10 psf (480 Pa)	5 psf (240 Pa)	7.5 psf (360 Pa)	10 psf (480 Pa)	40 psf (480 Pa)	5 psf (240 Pa)	7.5 psf (360 Pa)	10 psf (480 Pa)
1-5/8 (41.3)	L/420	11-2 (3400)	9-9 (2970)	8-11 (2720)	162S125-33	10-7 (3230)	9-8 (2950)	11-0 (3350)	9-7 (2920)	8-9 (2670)		
	1-5/8 (41.3)	L/120	13-0 (3960)	11-4 (3450)	10-4 (3150)	12-1 (3680)	10-7 (3230)	9-8 (2950)	11-0 (3350)	9-7 (2920)	8-9 (2670)	8-9 (2670)
	L/240	L/240	10-4 (3150)	9-0 (2740)	E	E	8-5 (2570)	E	8-9 (2670)	7-8 (2340)	E	E
	L/360	L/360	E	E	E	E	7-8 (2340)	E	E	E	E	E
2-1/2 (63.5)	L/420	15-1 (4600)	13-2 (4010)	11-9 (3580)	250S125-33	L/240	11-9 (3580)	10-2 (3100)	9-1 (2960)	11-770)		
	2-1/2 (63.5)	L/120	17-9 (5410)	15-6 (4720)	13-11 (4240)	16-5 (5000)	14-4 (4370)	12-10 (3910)	14-10 (4520)	13-0 (3960)	11-7 (3530)	11-7 (3530)
	L/240	250S125-33	13-11 (4240)	12-1 (3680)	10-11 (3330)	12-10 (3910)	11-2 (3400)	10-0 (3050)	11-7 (3530)	10-0 (3050)	8-11 (2720)	8-11 (2720)
	L/360	L/360	10-6 (3200)	9-5 (2870)	11-2 (3400)	9-8 (2950)	8-8 (2640)	10-0 (3050)	8-7 (2620)	7-8 (2340)		
3-1/2 (88.9) <sup>Ⓞ</sup>	L/420	19-1 (5820)	16-8 (5080)	15-2 (4620)	350S125-33	L/240	15-2 (4620)	13-2 (4010)	16-2 (5840)	14-7 (3630)		
	3-1/2 (88.9) <sup>F</sup>	L/120	22-6 (6860)	19-8 (5990)	17-10 (5440)	20-8 (6300)	18-1 (5510)	16-5 (5000)	18-6 (5640)	16-2 (5840)	14-9 (4500)	14-9 (4500)
	L/240	350S125-33	17-10 (5440)	15-6 (4720)	14-1 (4290)	16-5 (5000)	14-3 (4340)	12-11 (3940)	14-9 (4500)	12-9 (3890)	11-7 (3530)	11-7 (3530)
	L/360	L/360	13-7 (4140)	12-4 (3760)	14-5 (4340)	12-6 (3810)	11-4 (3450)	12-9 (3890)	11-2 (3400)	10-1 (3070)		
4 (101.6)	L/420	20-11 (6380)	18-3 (5560)	16-7 (5050)	400S125-33	L/240	16-7 (5050)	14-5 (4390)	13-0 (39510)	160)		
	4 (101.6)	L/120	25-1 (7650)	21-11 (6680)	19-11 (6070)	23-1 (7040)	20-2 (6150)	18-4 (5590)	20-9 (6320)	18-1 (5510)	16-5 (5000)	16-5 (5000)
	L/240	400S125-33	19-11 (6070)	17-4 (5280)	15-8 (4780)	18-4 (5590)	15-11 (4850)	14-5 (4390)	16-5 (5000)	14-3 (4340)	12-10 (3910)	12-10 (3910)
	L/360	L/360	15-0 (4570)	13-7 (4140)	15-11 (4850)	13-9 (4190)	12-6 (3810)	14-3 (4340)	12-4 (3760)	11-2 (3400)		
6 (152.4)	L/420	27-5 (8360)	24-0 (7320)	19-1 (5820)	600S125-33	L/240	21-9 (6630)	19-0 (5790)	17260)	19-3 (5260)		
	6 (152.4)	L/120	33-9 (10290)	29-6 (8990)	26-9 (8150)	30-10 (9400)	27-0 (8230)	24-6 (7470)	27-2 (8280)	23-10 (7260)	19-1 (5820)	19-1 (5820)
	L/240	600S125-33	26-9 (8150)	23-5 (7140)	21-3 (6480)	24-6 (7470)	21-4 (6500)	19-5 (5920)	21-7 (6580)	18-10 (5740)	17-3 (5260)	17-3 (5260)
	L/360	L/360	20-6 (6250)	18-7 (5660)	21-4 (6500)	1- (5720)	17-0 (5180)	18-10 (5740)	16050)	15-0 (4570)		

<sup>A</sup> Based on tests conducted with gypsum board attached with screws spaced 12 in. (305 mm) o.c. to framing members.

<sup>B</sup> Maximum stud heights also are applicable to walls sheathed with gypsum board greater than ½ in. (12.7 mm) thick and multiple layers of gypsum board.

<sup>C</sup> Maximum stud heights also are applicable to walls with studs spaced less than 24 in. (610 mm) o.c.

<sup>D</sup> Runner flanges need not be fastened to studs except as required by 5.3.2.1.

<sup>E</sup> The *Industry Designator* defines the cold formed steel framing member.

Example: 350S125-4833

350 designates the member web depth in 100ths of an inch, 350 = 3.50 in. (88.9 mm).

S designates the type of member, S = stud.

125 designates the member flange width in 100ths of an inch, 125 = 1.25 in. (32 mm).

- 33 designates the member base metal thickness in mils, 33 = 0.0329 in. (0.8365 mm).

<sup>F</sup> Data not available.

<sup>Ⓞ</sup> Also applicable to 3-5/8 in. (92.1 mm) stud depth, 362S125-33.

corner and from outside corner to vertical surface. Where the hanger or spacer length is not more than the maximum framing spacing allowed in Table 1 for the gypsum panel product thickness specified, hangers or spacers shall be located not more than 4 ft (1220 mm) on centers. Where the hanger or spacer length is more than the maximum framing spacing allowed, they become the attachment means and shall be spaced in accordance with Table 1.

## 6. Suspended and Furred Ceilings

### 6.1 Hangers and Inserts for Suspended Ceilings:

6.1.1 Sizes specified for wire, rods, and flats shall be in accordance with Table 5.

6.1.2 Hangers for supporting suspended ceilings shall be in accordance with Table 5.

6.1.3 Wire and rod hangers shall be saddle-tied around main runners and furring members so as to prevent turning or twisting of the member and to develop the full strength of the hangers (see Fig. 4).

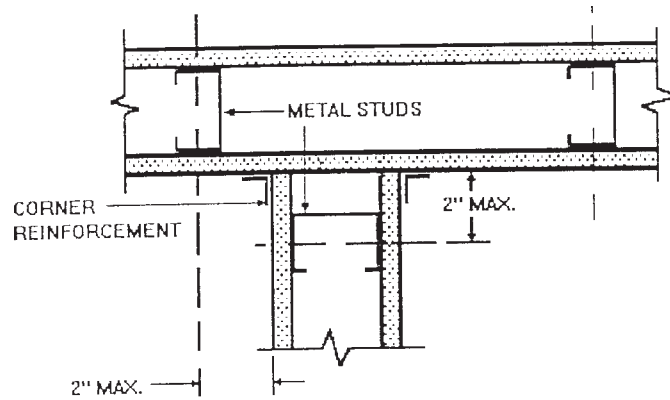

FIG. 1 Abutting Partition Detail

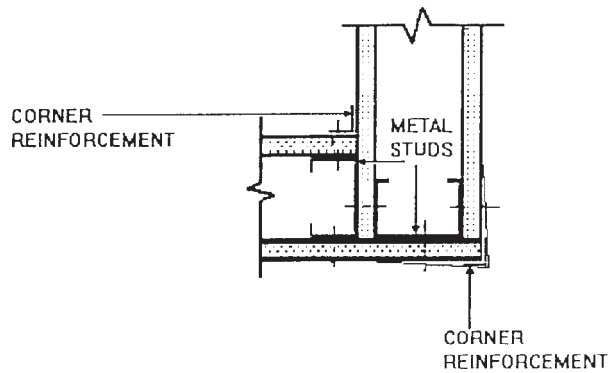

FIG. 2 Partition Corner Detail

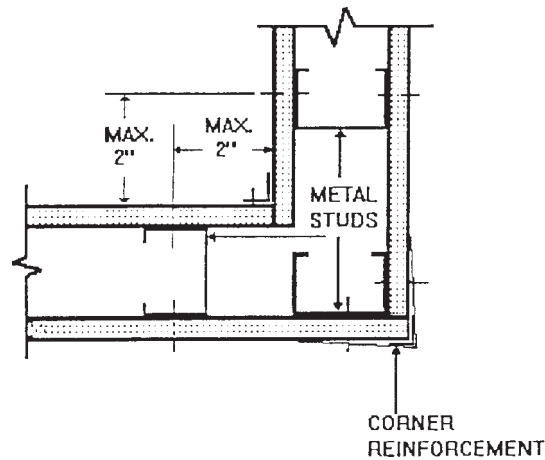

FIG. 3 Partition Corner Detail

6.1.4 Wire for attaching main runners and rigid furring channels directly to concrete beams and joists, to steel beams and joists, and to wood beams and joists shall be as specified in Table 3.

6.2 *Wood Construction*—Hangers for suspended ceilings under wood construction shall be as specified in Table 5, and shall be attached to supports by any of the following methods.

6.2.1 A hole shall be drilled through the wood member not less than 3 in. (76 mm) above the bottom with the upper end of the wire hanger passed through the hole and twisted three times around itself (see Fig. 5).

6.2.2 Three 12-penny nails shall be driven, on a downward slant, into the sides of the wood member with not less than 1¼ in. (32 mm) penetration and not less than 5 in. (130 mm) from the bottom edges, and not more than 36 in. (910 mm) on center with the upper end of the wire hanger wrapped around the nails and twisted three times around itself (see Fig. 6).

6.2.3 A loop shall be formed on the upper end of the wire hanger and secured to the wood member by not less than four 1½ in. (38 mm), 9-gage diameter wire staples driven horizontally or on a downward slant into the sides of the wood members, three near the upper end of the loop, and the fourth to fasten the loose end (see Fig. 7).

**TABLE 5 Suspended and Furred Ceilings, Minimum Sizes for Hangers**

Type of Hanger			Maximum Ceiling Area Supported, ft <sup>2</sup> (m <sup>2</sup> )	Minimum Size, in. (mm) [gage]
Hangers for Suspended Ceilings			14 (1.3)	0.1350 (3.43) [10] hanger wire
			16 (1.5)	0.1483 (3.77) [9] hanger wire
			18 (1.7)	0.1620 (4.12) [8] hanger wire
			20 (1.9)	3/16 (4.76) diameter mild steel rod
			22.5 (2.1)	7/32 (5.56) diameter mild steel rod
			25 (2.3)	1/4 (6.35) diameter mild steel rod
			28 (2.6)	1 by 3/16 (25.4 by 4.76) mild steel flat
Hangers for attaching main runners and furring directly to structural members	For supporting main runners	Hangers between structural members <sup>A</sup>	9 (0.8)	0.1055 (2.68) [12] hanger wire
			14 (1.3)	0.1350 (3.43) [10] hanger wire
			18 (1.7)	0.1620 (4.12) [8] hanger wire
	For supporting furring without a runner (wire loops at supports)	Double-wire loops at structural member <sup>A</sup>	9 (0.8)	0.0800 (2.03) [14] hanger wire
			14 (1.3)	0.1055 (2.68) [12] hanger wire
			18 (1.7)	0.1350 (3.43) [10] hanger wire
	Types of support:			
	Concrete	9 (0.8)	0.0800 (2.03) [14] hanger wire	
	Steel or Wood	9 (0.8)	0.0625 (1.59) [16] hanger wire (two loops) <sup>B</sup>	

<sup>A</sup> Inserts, special clips or screws, or other devices of equal strength shall be permitted.

<sup>B</sup> Two loops of 0.0475 in. (1.21 mm), No. 18-gage galvanized wire shall be permitted to be substituted for each loop of 0.0625 in. (1.59 mm), No. 16-gage wire for attaching steel furring to steel or wood joists.

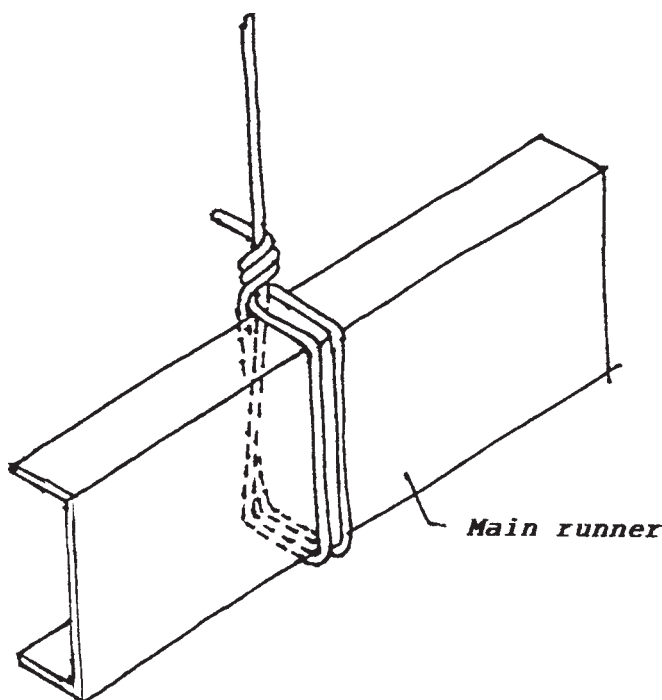

**FIG. 4 Saddle Tie**

6.2.4 Where supports for flooring are thicker than 1½ in. (38 mm) and are spaced more than 4 ft (1220 mm) on center, 1½ in. (38 mm) No. 1/0 (0.3065 in.) (7.78 mm) eye screws, or equivalent, spaced not greater than 3 ft (910 mm) on centers shall be screwed into the flooring with the upper end of the hanger inserted through the eye screws and twisted three times around itself.

6.2.5 *Flat Hangers*—Two holes shall be drilled in the upper end of the flat hangers and nailed to the sides of the wood members with 12d penny nails driven through holes and clinched. Nails shall be not less than 3 in. (76 mm) above the bottom edge of the framing member (see Fig. 8).

6.3 *Rigid Furring Channels*—Rigid furring channels applied directly to wood framing shall be applied with screws providing 1-in. (25.4 mm) penetration or as otherwise specified by the manufacturer of the furring channels.

6.4 *Flat Hangers and Inserts:*

6.4.1 *Inserts*—Where 1 by 3/16-in. (25 by 4.7-mm) inserts are used, 7/16-in. (11-mm) diameter holes shall be punched on the center line at the lower ends of the insert to permit flat hangers to be bolted tightly to the inserts with 3/8-in. (10-mm) diameter bolts.

6.4.2 *Hangers*—Lower ends of the flat hangers shall be bolted to the main runners or shall be bent tightly around the members



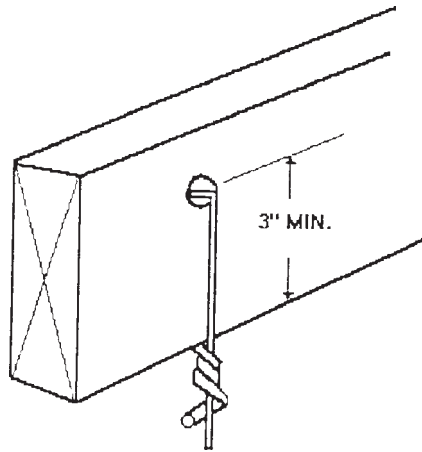

FIG. 5 Wire Hanger Attached to Wood Member Through a Drilled Hole

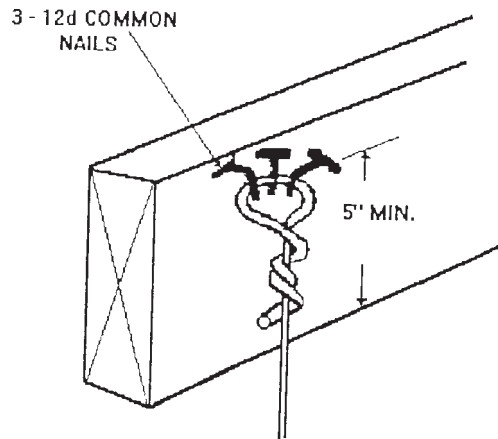

FIG. 6 Wire Hanger Attached to Wood Member Using Nails

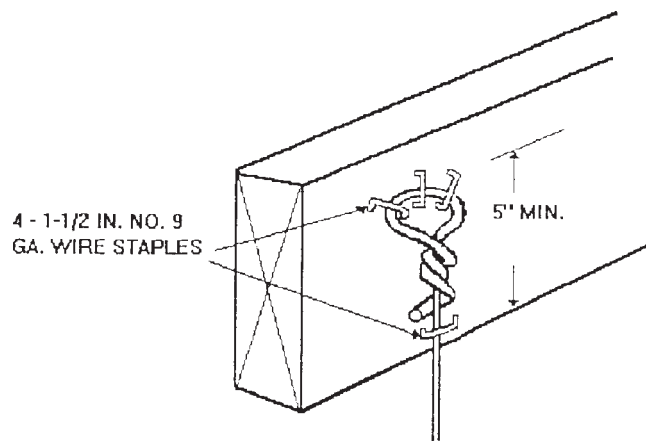

FIG. 7 Wire Hanger Attached to Wood Member Using Staples

and bolted tightly to the main part of the hanger with  $\frac{3}{8}$ -in. (9.5-mm) diameter bolts in a  $\frac{7}{16}$ -in. (11-mm) diameter hole (see Fig. 9), or machine screws.

6.4.3 *General*—Holes in both inserts and hangers shall not be nearer to the ends than  $\frac{3}{8}$  in. (10 mm).

6.5 *Main Runners for Suspended Ceilings*—Channels for the various spacings of hangers shall be as specified in Table 6.

6.5.1 Ends and sides of main runners and cross furring shall not come in contact with abutting masonry or reinforced concrete walls or partitions. Clearance of not less than 1 in. (25 mm) from ends and  $\frac{1}{8}$  in. (3 mm) from sides shall be provided. A channel shall be located within 6 in. (150 mm) of the paralleling walls to support the ends of the cross furring. The ends at walls shall be supported by hangers located not more than 6 in. (150 mm) from such ends.

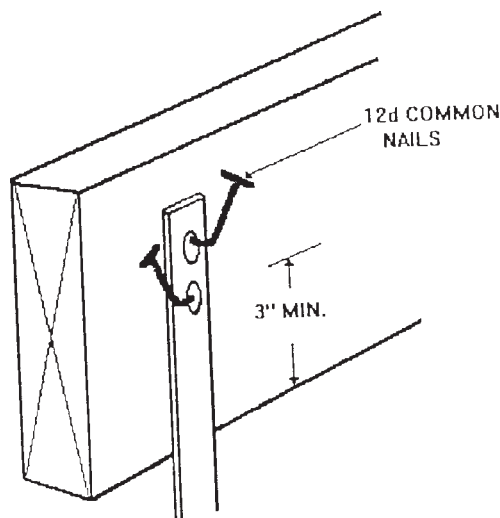

FIG. 8 Flat Hanger Attached to Wood Member Using Nails

TABLE 6 Allowable Spans, ft-in. (mm)  
Cold-Rolled Channel Main Runners<sup>A,B,C,D,E,F</sup>

Member Size, In (mm)	Member Weight lb/1000 ft (kg/m)	Span Condition <sup>G,H</sup>	Total Uniform Load = 4 psf (0.19 kPa) Member Spacing, in. (mm)				
			24 (610)	36 (914)	48 (1220)	60 (1520)	72 (1830)
¾ (19)	277 (0.412)	Simple	3-3 (990)	2-10 (860)	2-7 (790)	2-5 (740)	2-3 (690)
		2 or More	4-1 (1240)	3-6 (1070)	3-3 (990)	3-0 (910)	2-10 (860)
1½ (38)	414 (0.616)	Simple	5-1 (1550)	4-5 (1350)	4-0 (1220)	3-9 (1140)	3-6 (1070)
		2 or More	7-1 (2160)	6-2 (1880)	5-8 (173)	5-2 (1570)	4-10 (1470)
2 (51)	506 (0.753)	Simple	5-4 (1630)	4-8 (1420)	4-3 (1300)	4-0 (1220)	3-9 (1140)
		2 or More	7-5 (2260)	6-6 (1980)	5-11 (1800)	5-6 (1680)	5-2 (1570)
2½ (64)	597 (0.888)	Simple	5-7 (1700)	4-11 (1500)	4-5 (1350)	4-2 (1270)	3-11 (1190)
		2 or More	7-9 (2360)	6-9 (2060)	6-2 (1880)	5-9 (1750)	5-5 (1650)

Member Size, In (mm)	Member Weight lb/1000 ft (kg/m)	Span Condition <sup>G,H</sup>	Total Uniform Load = 6 psf (0.29 kPa) Member Spacing, in. (mm)				
			24 (610)	36 (914)	48 (1220)	60 (1520)	72 (1830)
¾ (19)	277 (0.412)	Simple	2-10 (860)	2-6 (780)	2-3 (690)	2-1 (630)	2-0 (610)
		2 or More	3-6 (1070)	3-1 (490)	2-10 (860)	2-7 (790)	2-5 (740)
1½ (38)	414 (0.616)	Simple	4-5 (1350)	3-11 (1190)	3-6 (1070)	3-3 (990)	3-1 (940)
		2 or More	6-2 (1880)	5-5 (1650)	4-10 (1470)	4-6 (1370)	4-2 (1270)
2 (51)	506 (0.753)	Simple	4-8 (1420)	4-1 (1240)	3-9 (1140)	3-6 (1070)	3-3 (990)
		2 or More	6-6 (1980)	5-8 (1730)	5-2 (1570)	4-10 (1470)	4-7 (1400)
2½ (64)	597 (0.888)	Simple	4-11 (1500)	4-3 (1300)	3-11 (1190)	3-8 (1120)	3-5 (1040)
		2 or More	6-9 (2060)	5-11 (1800)	5-5 (1650)	5-0 (1520)	4-9 (1450)

<sup>A</sup> Bare metal thickness of cold-rolled main runners shall be not less than 0.0538 in. (1.367 mm).

<sup>B</sup> Inside corner radii shall not be greater than ⅛ in. (3.19 mm).

<sup>C</sup> Spans based on upper flange of main runners laterally unbraced.

<sup>D</sup> Maximum deflection limited to 1/360 th of the span length.

<sup>E</sup> Steel yield stress, *F<sub>y</sub>*, shall be not less than 33 000 psi (228 MPa).

<sup>F</sup> Tabulated spans apply only to main runners with webs oriented vertically.

<sup>G</sup> "2 or More" spans refers to two or more continuous, equal spans.

<sup>H</sup> For the "2 or More" span condition, listed spans represent the center-to-center distance between adjacent supports.

6.5.2 When main runners and cross furring are spliced, the ends shall be overlapped not less than 12 in. (305 mm) with flanges interlocked and securely fastened near each end of the splice with double loops of No. 16-gage tie wire, minimum, or with screws.

6.6 Furring Members for Suspended or Furred Ceilings:

6.6.1 Furring members shall be spaced in accordance with Table 2 and Table 6.

6.6.2 Furring members shall be securely fastened to main runners and structural supports with special clips, screws, or equivalent attachments. Where required, rigid furring channels shall be saddle-tied to main runners with No. 16-gage tie wire, a double strand of 18-gage tie wire, or with screws (see Fig. 10).

6.6.3 When furring members are spliced, the ends shall be overlapped not less than 8 in. (203 mm) and securely fastened near each end of the splice with double loops of No. 16-gage tie wire or with screws.

6.6.4 Flanges of rigid furring channels shall be interlocked. Ends and sides of furring members shall not come in contact with abutting masonry or reinforced concrete walls or partitions.

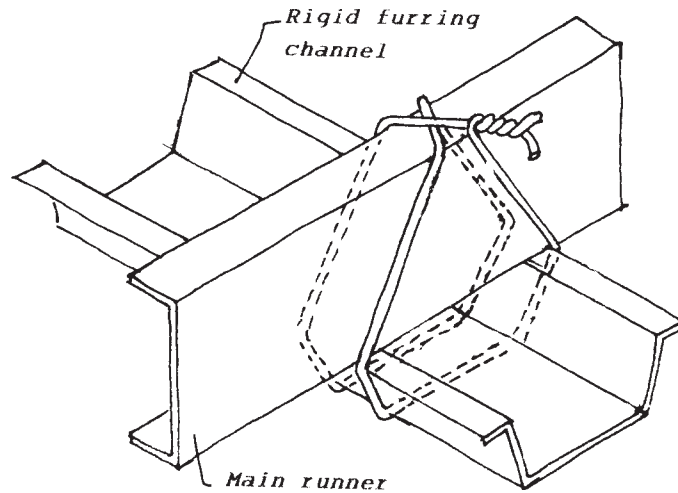

FIG. 10 Saddle Tie

6.7 *Grid Suspension System*—Main beams shall be suspended in parallel rows spliced together at their ends.

6.7.1 Hangers for supporting the main beams shall comply with the minimum size and ceiling area specified in Table 5.

6.7.2 Cross furring members of grid suspension systems shall interlock to the main beams in rows running perpendicular and spaced not to exceed maximums specified in Table 1. Cross furring members along the ceiling perimeter shall be supported by angle or channels attached to the wall.

**7. Product Delivery, Identification, and Marking**

7.1 All materials shall be delivered in original packages, containers, or bundles bearing the brand name and the name of the manufacturer or the supplier for whom the product is manufactured.

**8. Product Storage**

8.1 All materials shall be kept dry, preferably by being stored inside a building under a roof. Where necessary to store material outside, it shall be stacked off the ground, properly supported on a level platform, and fully protected from the weather.

**9. Keywords**

9.1 channel; framing; framing member; furring; grid suspension system; gypsum panel product; hangers; hanger wire; main runners; rigid furring channel; runner; stud; suspended ceiling; tie wire

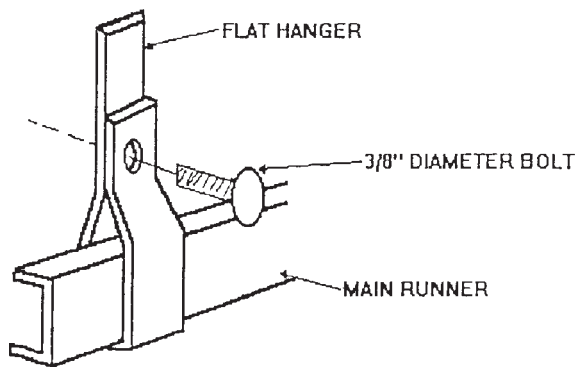

FIG. 9 Flat Hanger Attached to Main Runner Using Bolt

## SUMMARY OF CHANGES

This section identifies the location of changes to this specification that have been incorporated since the last issue. Committee C-11 has highlighted those changes that affect the technical interpretation or use of this specification.

■ ~~(1) Section 5.3.1.4 was modified.~~ Table 3 and Table 4 were revised.

*ASTM International takes no position respecting the validity of any patent rights asserted in connection with any item mentioned in this standard. Users of this standard are expressly advised that determination of the validity of any such patent rights, and the risk of infringement of such rights, are entirely their own responsibility.*

*This standard is subject to revision at any time by the responsible technical committee and must be reviewed every five years and if not revised, either reapproved or withdrawn. Your comments are invited either for revision of this standard or for additional standards and should be addressed to ASTM International Headquarters. Your comments will receive careful consideration at a meeting of the responsible technical committee, which you may attend. If you feel that your comments have not received a fair hearing you should make your views known to the ASTM Committee on Standards, at the address shown below.*

*This standard is copyrighted by ASTM International, 100 Barr Harbor Drive, PO Box C700, West Conshohocken, PA 19428-2959, United States. Individual reprints (single or multiple copies) of this standard may be obtained by contacting ASTM at the above address or at 610-832-9585 (phone), 610-832-9555 (fax), or [service@astm.org](mailto:service@astm.org) (e-mail); or through the ASTM website ([www.astm.org](http://www.astm.org)).*