



Designation: C 840 – 03

## Standard Specification for Application and Finishing of Gypsum Board<sup>1</sup>

This standard is issued under the fixed designation C 840; the number immediately following the designation indicates the year of original adoption or, in the case of revision, the year of last revision. A number in parentheses indicates the year of last reappraisal. A superscript epsilon ( $\epsilon$ ) indicates an editorial change since the last revision or reappraisal.

*This standard has been approved for use by agencies of the Department of Defense.*

### 1. Scope

1.1 This specification covers the minimum requirements for the methods of application and finishing of gypsum board, including related items and accessories.

1.2 Details of construction for a specific assembly to achieve the required fire resistance shall be obtained from reports of fire-resistance tests, engineering evaluations, or listings from recognized fire testing laboratories.

1.2.1 Where this specification is more stringent (size or thickness of framing; size and spacing of fasteners) than the fire-rated construction, this specification shall govern.

1.3 Where sound control is required for a gypsum board assembly, details of construction shall be in accordance with reports of acoustical tests of assemblies that have met the required acoustical values.

1.4 Unheated spaces above gypsum board ceilings shall be properly ventilated (see Appendix X2).

1.5 The various application systems are located in the following sections:

I	Application of Single-Ply Gypsum Board to Wood Framing Members	8
II	Application of Two-Ply Gypsum Board to Wood Framing Members	9
III	Application of Gypsum Board by Adhesive Nail-On to Wood Framing Members	10
IV	Semi-Solid Gypsum Board Partitions	11
V	Solid Gypsum Board Partitions	12
VI	Application of Gypsum Board with Adhesives to Interior Masonry or Concrete Walls	13
VII	Application of Gypsum Board to Rigid Foam Insulation	14
VIII	Application of Gypsum Board to Steel Framing and Furring	15
IX	Arches and Bending Radii	16
X	Application of Gypsum Board to Receive Tile by Adhesive Application	17
XI	Exterior Application of Gypsum Wallboard and Exterior Gypsum Soffit Board	18
XII	Floating Interior Angles	19
XIII	Control (Expansion) Joints	20
XIV	Foil-Backed Gypsum Board	21

The values stated in inch-pound units are to be regarded as the standard. The SI (metric) values given in parentheses are approximate and are provided for information purposes only.

1.6 The text of this specification references notes and footnotes which provide explanatory material. These notes and footnotes (excluding those in tables and figures) shall not be considered as requirements of the specification.

1.7 The following precautionary caveat pertains only to Sections 6-23. *This standard does not purport to address all of the safety concerns, if any, associated with its use. It is the responsibility of the user of this standard to establish appropriate safety and health practices and determine the applicability of regulatory limitations prior to use.*

1.7.1 For specific precautionary statements, see 4.1.1, 4.1.2, and 22.5.

### 2. Referenced Documents

#### 2.1 ASTM Standards:

- C 11 Terminology Relating to Gypsum and Related Building Materials and Systems<sup>2</sup>
- C 36/C 36M Specification for Gypsum Wallboard<sup>2</sup>
- C 442/C 442M Specification for Gypsum Backing Board, Gypsum Coreboard, and Gypsum Shaftliner Board<sup>2</sup>
- C 475/C 475M Specification for Joint Compound and Joint Tape for Finishing Gypsum Board<sup>2</sup>
- C 514 Specification for Nails for the Application of Gypsum Board<sup>2</sup>
- C 557 Specification for Adhesives for Fastening Gypsum Wallboard to Wood Framing<sup>3</sup>
- C 630/C 630M Specification for Water-Resistant Gypsum Backing Board<sup>2</sup>
- C 645 Specification for Nonstructural Steel Framing Members<sup>2</sup>
- C 754 Specification for Installation of Steel Framing Members to Receive Screw-Attached Gypsum Panel Products<sup>2</sup>
- C 931/C 931M Specification for Exterior Gypsum Soffit Board<sup>2</sup>

<sup>1</sup> This specification is under the jurisdiction of ASTM Committee C11 on Gypsum and Related Building Materials and Systems and is the direct responsibility of Subcommittee C11.03 on Specifications for the Application of Gypsum and Other Products in Assemblies.

Current edition approved June 10, 2003. Published September 2003. Originally approved in 1979. Last previous edition approved in 2002 as C 840 – 02.

<sup>2</sup> Annual Book of ASTM Standards, Vol 04.01.

<sup>3</sup> Annual Book of ASTM Standards, Vol 15.06.

C 954 Specification for Steel Drill Screws for the Application of Gypsum Panel Products or Metal Plaster Bases to Steel Studs from 0.033 in. (0.84 mm) to 0.112 in. (2.84 mm) in Thickness<sup>2</sup>

C 1002 Specification for Steel Self-Piercing Tapping Screws for the Application of Gypsum Panel Products or Metal Plaster Bases to Wood Studs or Steel Studs<sup>2</sup>

C 1007 Specification for the Installation of Load Bearing (Transverse and Axial) Steel Studs and Related Accessories<sup>2</sup>

C 1047 Specification for Accessories for Gypsum Wallboard and Gypsum Veneer Base<sup>2</sup>

C 1395/C 1395M Specification for Gypsum Ceiling Board<sup>2</sup>

2.2 U.S. Department of Commerce Publication:

PS20 American Softwood Lumber Standard<sup>4</sup>

2.3 ANSI Standard:

ANSI A 136.1 Organic Adhesives for Installation of Ceramic Tile, Type I and Type II<sup>5</sup>

### 3. Terminology

3.1 *Definitions*—Definitions shall be in accordance with Terminology C 11.

3.2 *Descriptions of Terms Specific to This Standard:*

3.2.1 *all-purpose compound, n*—a compound formulated and manufactured to serve as a taping or finishing compound, or both.

3.2.2 *critical lighting, n*—a condition where interior surfaces are flooded by natural or artificial lighting at an oblique angle.

3.2.3 *decoration, n*—paint (including primers), texture, coatings, and coverings such as wallpaper and sheet plastic materials designed to conceal or protect the surface of the gypsum board (see Appendix X3).

3.2.4 *dry type, n*—a compound in powder form to be mixed with water before use.

3.2.5 *drying type, n*—a compound that hardens by the evaporation of the vehicle used to make the paste.

3.2.6 *drywall primer, n*—a paint material specifically formulated to fill the pores and minimize the suction difference between gypsum board surface paper and the compound used on finished joints, angles, fastener heads and accessories, and over skim coatings.

3.2.7 *face panel, n*—outside ply of multiple layer gypsum board assemblies.

3.2.8 *finished wallboard, n*—wallboard that has had the joints taped, has had the joints, fastener heads, and flanges of accessories concealed with joint compound, and has been sanded to prepare the surface to receive job applied decoration.

3.2.9 *finishing, n*—the preparation of gypsum board surfaces to receive the field application of decoration.

3.2.10 *finishing compound (sometimes called topping compound), n*—a compound used for successive coats over the taping or all-purpose compound that provides a smooth and level surface for the application of decoration.

3.2.11 *finishing of accessories, n*—the application of compound to flanges of accessories to create a monolithic surface.

3.2.12 *flange, n*—that part of an accessory extending over the face of the gypsum wallboard intended to become a part of the monolithic plane of the prepared surface.

3.2.13 *framing member, n*—that portion of the framing, furring, and blocking to which the gypsum board is attached.

3.2.14 *harden, v*—a condition reached when the compound has lost its plasticity to an arbitrary degree, measured in resistance to penetration or deformation.

3.2.15 *joint photographing, n*—a condition where the finished joint areas visible after final decoration.

3.2.16 *joint tape, n*—a strip of material designed to be embedded in compound to reinforce joints, cracks, or other small openings in or between gypsum boards.

3.2.17 *joint treatment, n*—application of joint tape and compound to the joint between gypsum boards.

3.2.18 *laminating compound, n*—a compound (abrasive) used to adhere gypsum board to gypsum board or other monolithic materials.

3.2.19 *parallel or vertical application, n*—gypsum board applied with the edges parallel to the framing member to which it is attached.

3.2.20 *perpendicular or horizontal application, n*—gypsum board application with the edges applied at right angles to the framing member to which it is attached.

3.2.21 *ready-mix type, n*—a factory-prepared compound ready to be used without the addition of water.

3.2.22 *required, adj*—pertaining to a mandatory obligation imposed by a force outside this standard, such as a building code, project specification, contract, or purchase order.

3.2.23 *setting type, n*—a compound that hardens by a chemical reaction and increases in straight through drying.

3.2.24 *skim coat, n*—a thin coat of skim coat compound applied over the finished wallboard surface.

3.2.25 *skim coat compound, n*—joint compound, or a compound specifically formulated and manufactured for use as a skim coat.

3.2.26 *specified, adj*—pertaining to a mandatory requirement of this standard or a referenced requirement (see 3.2.20).

3.2.27 *spotting fastener heads, n*—the application of compound to cover the fastener head to create a monolithic surface.

3.2.28 *taping compound (sometimes called embedding compound), n*—a compound used for embedding and bonding joint tape and for the first coat over the heads of fasteners and flanges of accessories.

3.2.29 *taping of joints, n*—the application of compound and joint reinforcing tape to the joints between adjoining gypsum boards.

3.2.30 *treated joint, n*—a joint between gypsum boards that has been covered with joint tape and joint compound as specified in 22.3.2.

3.2.30.1 *Discussion*—Strip moldings or similar devices shall be permitted.

### 4. Environmental Conditions

4.1 *Application of Gypsum Board, Joint Treatment Materials, and Adhesives*—Room temperature shall be maintained at not less than 40°F (4°C) during application of gypsum board

<sup>4</sup> Available from U.S. Government Printing Office, Washington, DC 20402.

<sup>5</sup> Available from American National Standards Institute (ANSI), 25 W. 43rd St., 4th Floor, New York, NY 10036.

except when adhesive is used for the attachment of gypsum board. For the bonding of adhesive, joint treatment, texturing, and decoration, the room temperature shall be maintained at not less than 50°F (10°C) for 48 h prior to application and continuously thereafter until completely dry.

4.1.1 When a temporary heat source is used, the temperature shall not exceed 95°F (35°C) in any given room or area.

4.1.2 Adequate ventilation shall be maintained in the working area during installation and curing period.

4.2 Gypsum board shall be protected from direct exposure to rain, snow, sunlight, or other excessive weather conditions.

NOTE 1—Where manufacturers' recommendations differ from the above, follow their recommendations.

4.3 Ready-mixed joint compounds shall be protected from freezing, exposure to extreme heat, and direct sunlight.

## 5. Materials and Manufacture

5.1 *Gypsum Boards*—A family of gypsum sheet products as defined in Terminology C 11.

5.1.1 *Type X (Special Fire-Resistant) Gypsum Wallboard, Gypsum Backing Board, Water-Resistant Gypsum Backing Board, or Exterior Gypsum Soffit Board*—Gypsum board that provides a greater degree of fire resistance than regular gypsum board as defined in Specifications C 36/C 36M, C 442/C 442M, C 630/C 630M and C 931/C 931M.

5.1.2 *Foil-Backed Gypsum Wallboard or Gypsum Backing Board*—Regular or Type X gypsum board with foil laminated to the back surface. The foil is a vapor retarder.

5.1.3 *Predecorated Gypsum Board*—Gypsum board with a decorative wall covering or coating applied in-plant by the gypsum board manufacturer.

5.2 *Gypsum Wallboard*—See Specification C 36/C 36M.

5.3 *Gypsum Backing Board and Coreboard*—See Specification C 442/C 442M.

5.4 *Water-Resistant Gypsum Backing Board*—See Specification C 630/C 630M.

5.5 *Exterior Gypsum Soffit Board*—See Specification C 931/C 931M.

5.6 *Gypsum Ceiling Board*—See Specification C 1395/C 1395M.

5.7 *Finishing Materials:*

5.7.1 *Compounds*—Taping compound, finishing compound, and all-purpose compound shall meet the requirements of Specification C 475/C 475M.

5.7.2 Mix compounds in accordance with the manufacturers' directions.

5.7.3 *Joint Tape*—See Specification C 475/C 475M.

5.8 *Fasteners:*

5.8.1 *Nails*—See Specification C 514.

5.8.2 *Screws:*

5.8.2.1 See Specification C 1002 for screws for fastening gypsum board to wood members, steel members less than 0.03 in thickness, and to gypsum board.

5.8.2.2 See Specification C 754 and Specification C 954 for screws for fastening gypsum board to steel members from 0.033 to 0.112 in. in thickness.

5.8.3 *Staples*—No. 16 USS gage flattened galvanized wire staples with 7/16-in. (11.1-mm) wide crown outside measure-

ment. Length of legs according to the following tables. Legs shall have divergent points.

NOTE 2—Use only for the base ply of two-ply gypsum board application.

Length of Legs,		Thickness of Gypsum Board,	
in.	mm	in.	mm
7/8	22.2	1/4	6.4
1	25.4	3/8	9.5
1 1/8	28.6	1/2	12.7
1 1/4	31.8	5/8	15.9

5.9 *Adhesives:*

5.9.1 *Fastening Gypsum Board to Wood Framing*—See Specification C 557.

5.9.2 *Fastening Gypsum Board to Steel Framing*—As specified by the manufacturer.

5.9.3 *Laminating Gypsum Board to Gypsum Board*—Laminating compounds, taping compound, or adhesive shall be as specified by the manufacturer.

NOTE 3—Adhesives for the installation of ceramic tile, see Appendix X4.

5.10 *Framing Members:*

5.10.1 Wood framing members shall conform to PS20, American Softwood Lumber Standards. The surface to which abutting edges or ends are attached shall be not less than 1 1/2 in. (38.1 mm) wide. For internal corners or angles, the bearing surface shall not be less than 3/4 in. (19.1 mm).

5.10.2 *Steel Studs, Furring Channels, and Runners, Non-Load Bearing*—See Specification C 645.

5.10.3 *Gypsum Studs*—Specification C 36/C 36M or C 442/C 442M, not less than 1 in. (25.4 mm) thick by 6 in. (152 mm) wide. Studs shall be either solid or laminated.

5.11 *Accessories*—See Specification C 1047.

5.12 *Water*—Water shall be clean, fresh, and potable (suitable for domestic consumption).

5.13 *Face Panels*—Face panels shall be 1/2 in. (12.7 mm), 5/8 in. (15.9 mm), or multiple laminations of regular or Type X gypsum board.

5.14 *Core Board*—Core board shall be 3/4 in. (19.1 mm) or 1 in. (25.4 mm) either single thickness or multiple layers to the required thickness.

## 6. Substrate, Surface Preparation

6.1 The attachment surface of any framing member shall not vary more than 1/8 in. (3.2 mm) from the plane of the faces of adjacent framing members.

6.2 Wood framing shall be as straight and true as possible. Wood framing shall be securely attached following acceptable engineering practices and as required for the intended design.

NOTE 4—For installation of wood framing, see Appendix X5.

6.3 Metal framing members shall be of the proper size and design for their intended use and shall be installed in accordance with Specifications C 754 or C 1007 as required.

6.4 Masonry or concrete walls shall be dry, free of dust, oil, or form release agents, protrusions or voids, or foreign matter that inhibit bond for adhesively applied gypsum board.



6.5 All framing members and substrate shall be installed so that after the gypsum board has been applied, the finished surface will be in an even plane.

6.6 Gypsum board shall be kept free of any dirt, oil, or other foreign matter that cause a lack of bond. Foreign matter shall be removed.

6.7 All dents or gouges on the face of the gypsum board shall be brought up to a smooth level plane with the surface of the board.

6.8 Mechanical fasteners shall be set below the plane of the surface of the board.

6.9 All joints shall be true and even.

6.10 All gypsum board shall be tight against the framing member or substrate.

6.11 Deflection at design load of horizontal (ceiling) framing members supporting gypsum board shall be not more than  $L/240$  of the span.

## 7. Application of Gypsum Board

### 7.1 General:

7.1.1 *Method of Cutting and Installation*—Gypsum board shall be cut by scoring and breaking or by sawing, working from the face side. When cutting by scoring, the face paper shall be cut with a sharp knife or other suitable tool. Gypsum board shall be broken by snapping the gypsum board in the reverse direction, or cut the back paper with a knife or suitable tool.

7.1.2 Cut edges and ends of the gypsum board shall be smoothed to obtain neat joints when installed. Holes for pipes, fixtures, or other small openings shall be scored on the back and the face in outline before removal or cut out with a saw or special tool designed for this purpose. Where gypsum board meets projecting surfaces, it shall be scribed and cut neatly.

7.1.3 When gypsum board is to be applied to both ceiling and walls, the gypsum board shall be applied first to the ceiling and then to the walls.

7.1.4 Where used at edges or ends, fasteners shall be spaced not more than 1 in. (25 mm) from edges and not less than  $\frac{3}{8}$  in. (9.5 mm) from edges and ends of gypsum board (except where floating angles are used). Perimeter fastening into the partition plate or sole at the top and bottom shall not be required except where the fire ratings, structural performance, or other special conditions require such fastening. While driving the fasteners, the gypsum board shall be held in firm contact with the underlying support. Application of fasteners shall proceed from the center or field of the gypsum board to the ends and edges.

7.1.5 Nails shall be driven with the heads slightly below the surface of the gypsum board, avoiding damage to the face and core of the board, such as breaking the paper or fracturing the core.

7.1.6 Screws shall be driven to provide screwhead penetration just below the gypsum board surface without breaking the surface paper of the gypsum board or stripping the framing member around the screw shank.

7.1.7 Staples shall be driven with the crown parallel to the framing members, in such a manner that the crown bears tightly against the gypsum board without cutting into the face paper.

7.1.7.1 Staple attachment shall be restricted to the base plies only of gypsum board in a multi-ply system.

7.1.8 The gypsum board shall be kept tight against the framing.

7.1.9 The external corners shall be protected with a metal corner bead or other suitable type of corner protection that shall be attached to supporting construction with fasteners or a crimping tool nominally 6 in. (152 mm) on centers (see Section 3 and Fig. 1).

7.2 Gypsum board shall not be used where it will be exposed to temperatures more than 125°F (52°C) for extended periods of time.

7.3 Gypsum board joints shall be located so that no joint will align with the edge of an opening unless control joints are to be installed at these locations.

7.4 Joints shall be staggered, and joints on opposite sides of a partition shall not occur on the same stud.

7.5 Gypsum board used in building construction shall be not less than 8 in. (203 mm) from the finished grade in fully weather and water protected siding systems, and not less than 12 in. (305 mm) from the ground within properly drained and ventilated crawl spaces. Where ground moisture or humidity is extreme and/or continuous, the crawl space ground surface shall be covered with a vapor barrier.

## 8. System I: Application of Single-Ply Gypsum Board to Wood Framing Members

8.1 The maximum spacing for framing members for single-ply gypsum board assembly shall not exceed those shown in Table 1.

8.1.1 The  $\frac{1}{4}$ -in. (6.4-mm) thick gypsum board shall not be used in single-ply applications on either walls or ceilings.

8.2 In single-ply installation, all ends and edges of gypsum board shall occur over framing members or other solid backing except where treated joints occur at right angles to framing or furring members.

8.3 End joints shall be staggered and joints on opposite sides of a partition shall be arranged to occur on alternate framing members.

8.4 Length of nails shall be as shown in Table 2.

8.4.1 Where a specific degree of fire resistance is required for gypsum board assemblies, nails of the same length, shank diameter, and head bearing area, as those described in the fire test report, shall be used.

8.4.2 *Single Nailing*—Nails shall be spaced a maximum of 7 in. (177.8 mm) on centers on ceilings, and a maximum of 8 in. (203.2 mm) on centers on walls (see Fig. 2).

8.4.3 *Double Nailing*—Nails shall be spaced as shown in Fig. 3 and driven as follows:

8.4.3.1 Starting at the center of the gypsum board, nails shall be applied as shown in solid dots in row 1, then rows 2 and 2A, 3 and 3A, 4 and 4A, always nailing from center to edges of sheet. The gypsum board shall be kept tight against the framing.

8.4.3.2 Second nails, shown by circles, shall be applied in the same manner as the first nails, also starting at row 1.

8.4.3.3 As an alternative procedure, the second nail shall be applied immediately after all nails in each row are driven in accordance with 8.4.3.2.

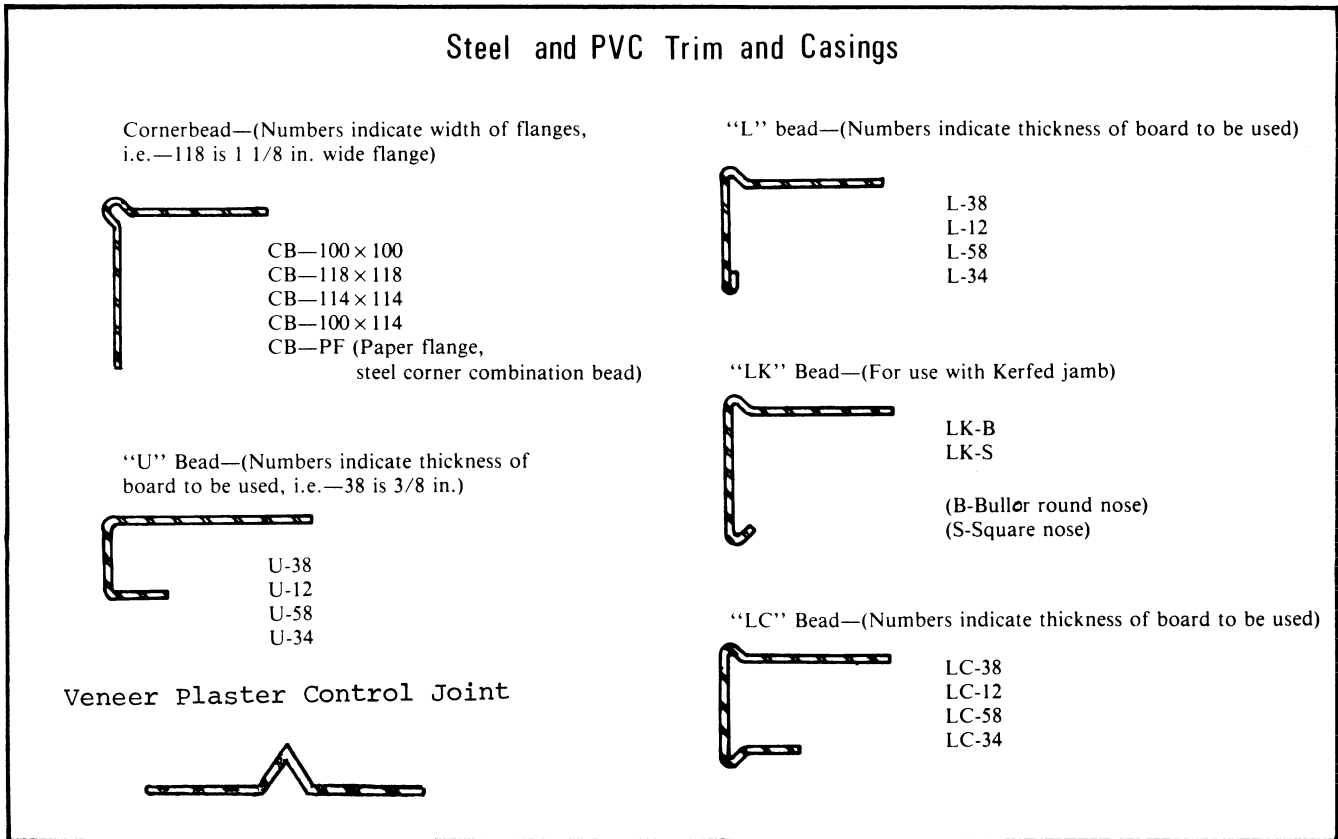

NOTE—All dimensions are in inch-pound units.

FIG. 1 Accessories

TABLE 1 Maximum Framing Spacing for Single-Ply Construction<sup>A</sup>

Single-Ply Gypsum Board Thickness, in. (mm)	Application <sup>B</sup>	Maximum Framing Members On Centers Spacing, in. (mm)
<i>Ceilings:</i>		
3/8 (9.5) <sup>C</sup>	perpendicular	16 (406.4)
1/2 (12.7)	parallel	16 (406.4)
5/8 (15.9)	parallel	16 (406.4)
1/2 (12.7)	perpendicular	24 (609.6)
5/8 (15.9)	perpendicular	24 (609.6)
<i>Sidewalls:</i>		
3/8 (9.5)	perpendicular or parallel	16 (406.4)
1/2 (12.7)	perpendicular	24 (609.6)
or	or	
5/8 (15.9)	parallel	

<sup>A</sup> Gypsum board ceilings to receive hand or spray-applied water-based texture material shall be applied perpendicular to framing and shall be either (i) 1/2 in. (12.7 mm) Gypsum Ceiling Board (see Specification C 1395/C 1395M) applied to framing not more than 24 in. (610 mm) on center, or (ii) other gypsum boards not less than 1/2 in. (12.7 mm) thick for 16 in. (406 mm) on center framing and not less than 5/8 in. (15.9 mm) thick for 24 in. (610 mm) on center framing.

<sup>B</sup> Nails for gypsum board applied over existing surfaces shall have a flat head and diamond point, and shall penetrate not less than 7/8 in. (22.2 mm), nor more than 1 1/4 in. (31.8 mm) into the framing member.

<sup>C</sup> 3/8-in. (9.5-mm) single-ply gypsum board shall not be applied to ceilings where the gypsum board supports insulation.

TABLE 2 Nail Lengths for Single-Ply Gypsum Board Assembly

Gypsum Board Thickness, in. (mm)	Minimum Nail Length, in. (mm)
Application of gypsum board over existing surfaces:	Flat or concave head, diamond or needle point of such length as to provide not less than 7/8 in. (22.2 mm) nor more than 1 1/4 in. (31.8 mm) penetration into the following framing members:
3/8 (9.5)	1 1/4 (31.8)
1/2 (12.7)	1 3/8 (34.9)
5/8 (15.9)	1 1/2 (38.1)

8.5 *Spacing of Screws*—Screws shall be spaced not more than 12 in. (304.8 mm) on centers along framing members for ceilings and 16 in. (406.4 mm) on centers for walls where the framing members are 16 in. on centers. Screws shall be spaced not more than 12 in. on centers along framing members for ceilings and walls where the framing members are 24 in. (609.6 mm) on centers.

8.5.1 When using a combination of fasteners consisting of nails along the perimeter and screws in the field of the gypsum board, the spacing between a nail and an adjacent screw shall be not more than the spacing specified for screws in 8.5.

## 9. System II: Application of Two-Ply Gypsum Board to Wood Framing Members

9.1 The maximum spacings for framing members for two-ply gypsum board assemblies shall not exceed those shown in Tables 3 and 4.

8.4.3.4 Single nailing shall be used on the perimeter of the gypsum board, unless otherwise specified.

8.4.3.5 Nails shall be inspected for compliance with 7.1.5 after the second nails have been set.

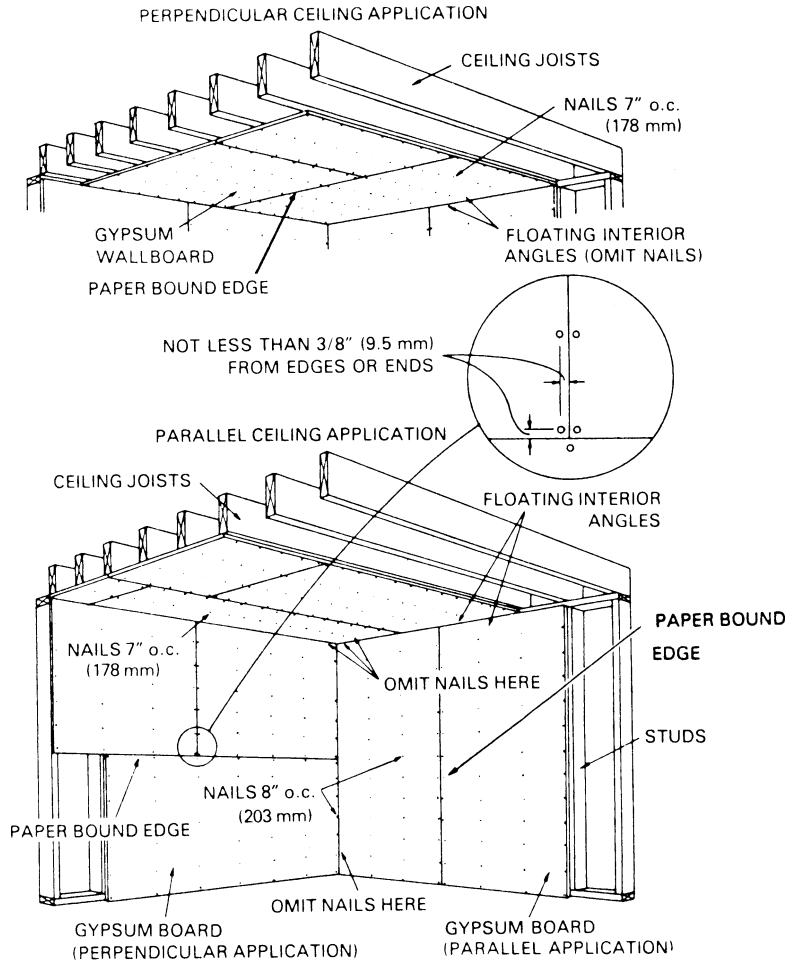

FIG. 2 Single Nailing

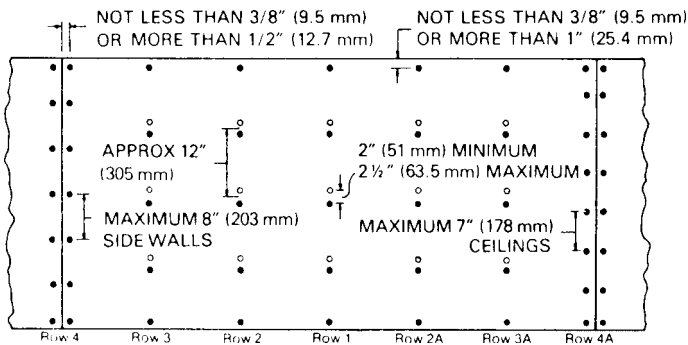

FIG. 3 Double Nailing

NOTE 5—See Section 2 for adhesive application method.

9.2 The base ply of gypsum board shall be applied with nails, screws, or staples of the size and type required in Sections 5, 7, and 8. Fastener lengths for 1/4-in. (6.4-mm) thick gypsum board shall be of sufficient length to penetrate wood framing members not less than 7/8 in. (22.2 mm) for nails or 5/8 in. (15.9 mm) for screws.

9.2.1 Base layer end joints parallel to and on the same side of framing members shall be staggered between alternate courses of gypsum board and from base layer joints on the opposite side of the framing members.

9.2.2 Base layer edge joints parallel to framing members shall be staggered on opposite sides of the framing members.

9.3 When adhesive is not used between the plies, the two plies of gypsum board shall be applied as indicated in Tables 3 and 5. The face ply shall be applied with the number of nails or screws required for normal single-ply application. Nails used for the face ply shall be long enough to penetrate not less than 7/8 in. (22.2 mm) into wood framing members. Screw length shall be long enough to penetrate not less than 5/8 in. (15.9 mm) into wood framing. Face ply joints that are parallel to framing shall fall over framing members and be offset from the base ply joints when two plies of gypsum board are parallel.

9.4 When an adhesive is used between the plies, the two plies shall be applied as indicated in Table 4. If the two plies are applied in parallel direction, the joints of the face ply shall be offset from the base ply.

9.4.1 Joints in the face ply need not occur over the framing members. The adhesive used between the two plies of gypsum board shall be uniformly applied over the back surface of the face ply of the gypsum board before it is erected or to the face surface of the base ply. The face ply of gypsum board shall be placed in position and fastened with nails or screws to hold gypsum board in place until the adhesive develops a bond.

**TABLE 3 Maximum Framing Spacing for Two-Ply Assemblies, Fasteners Only, No Adhesive Between Plies<sup>A</sup>**

Gypsum Board Thickness, in. (mm)		Application Direction		Maximum On Centers Spacing of Framing, in. (mm)
Base Ply	Face Ply	Base Ply	Face Ply	
<i>Ceilings:</i>				
1/4 (6.4)	3/8 (9.5) or 1/2 (12.7)	perpendicular	perpendicular	16 (406.6)
3/8 (9.5)	3/8 (9.5) or 1/2 (12.7)	perpendicular	perpendicular	16 (406.6)
1/2 (12.7)	3/8 (9.5) or 1/2 (12.7)	parallel	perpendicular	16 (406.6)
1/2 (12.7)	1/2 (12.7) or 5/8 (15.9)	perpendicular	perpendicular	24 (609.6)
5/8 (15.9) <sup>B</sup>	1/2 (12.7) or 5/8 (15.9)	perpendicular	perpendicular	24 (609.6)
<i>Walls:</i>				
1/4 (6.4)	1/4 (6.4) or 3/8 (9.5) or 1/2 (12.7)	perpendicular or parallel	perpendicular or parallel	16 (406.6)
3/8 (9.5)	1/4 (6.4) or 3/8 (9.5)	perpendicular or parallel	perpendicular or parallel	16 (406.6)
1/2 (12.7)	1/4 (6.4) or 3/8 (9.5) or 1/2 (12.7)	perpendicular or parallel	perpendicular or parallel	24 (609.6)
5/8 (15.9)	1/4 (6.4) or 3/8 (9.5) or 1/2 (12.7) or 5/8 (15.9)	perpendicular or parallel	perpendicular or parallel	24 (609.6)

<sup>A</sup> Gypsum board ceilings to receive hand or spray-applied water-based texture material shall be applied perpendicular to framing and shall be either (i) 1/2 in. (12.7 mm) Gypsum Ceiling Board (see Specification C 1395/C 1395M) applied to framing not more than 24 in. (610 mm) on center, or (ii) other gypsum boards not less than 1/2 in. (12.7 mm) thick for 16 in. (406 mm) on center framing and not less than 5/8 in. (15.9 mm) thick for 24 in. (610 mm) on center framing.

<sup>B</sup> 5/8-in. (15.9-mm) board shall be permitted to be applied perpendicularly at 16 in. (406 mm) spacing.

**TABLE 4 Maximum Framing Spacing for Two-Ply Assembly Fasteners with Adhesive Between Plies<sup>A</sup>**

Gypsum Board Thickness, in. (mm)		Application Direction		Maximum On Centers Spacing of Framing, in. (mm)
Base Ply	Face Ply	Base Ply	Face Ply	
<i>Ceilings:</i>				
1/4 (6.4)	1/4 (6.4) or 3/8 (9.5) or 1/2 (12.7)	perpendicular	perpendicular	16 (406.6)
3/8 (9.5)	1/4 (6.4) or 3/8 (9.5) or 1/2 (12.7)	perpendicular	perpendicular	16 (406.6)
1/2 (12.7)	1/4 (6.4) or 3/8 (9.5) or 1/2 (12.7)	parallel	perpendicular	16 (406.6)
1/2 (12.7)	1/4 (6.4) or 1/2 (12.7) or 5/8 (15.9)	perpendicular	perpendicular	24 (609.6)
5/8 (15.9)	1/4 (6.4) or 1/2 (12.7) or 5/8 (15.9)	perpendicular	perpendicular	24 (609.6)
<i>Walls:</i>				
1/4 (6.4)	1/4 (6.4) or 3/8 (9.5) or 1/2 (12.7)	perpendicular or parallel	perpendicular or parallel	16 (406.6)
3/8 (9.5)	1/4 (6.4) or 3/8 (9.5)	perpendicular or parallel	perpendicular or parallel	16 (406.6)
1/2 (12.7)	1/4 (6.4) or 3/8 (9.5) or 1/2 (12.7)	perpendicular or parallel	perpendicular or parallel	24 (609.6)
5/8 (15.9)	1/4 (6.4) or 1/2 (12.7) or 5/8 (15.9)	perpendicular or parallel	perpendicular or parallel	24 (609.6)

<sup>A</sup> Adhesive between plies shall be dried or cured prior to joint treatment application.

**TABLE 5 Fastener Spacing, Base-Ply of Two-Ply System, in. (mm) On Centers**

	Nails	Screws	Staples
No adhesive between plies	24 (609.6)	24 (609.6)	16 (406.4)
Adhesive between plies	See 9.3	See 9.3	7 (177.8)

9.4.2 Permanent fasteners shall be used around the perimeter 12 in. (304.8 mm) on centers and 16 in. (406.4 mm) on centers along framing members for the face ply of gypsum board applied on ceilings.

9.4.3 In place of nails and screws, the face ply of gypsum board applied on walls shall be held in position by shoring with props and headers, or other temporary support to ensure a pressure for bonding. Permanent fasteners shall be used on top and bottom of wall not more than 16 in. (406 mm) on centers. Nails or screws used to hold the gypsum board face ply shall be left in place and finished in the same manner as for single-ply gypsum board application (see Section 10).

9.5 Base layer joints and fasteners shall not be required to be taped or finished. Face layer joints and fasteners in multi-layer systems shall not be required to be finished unless required for appearance or decoration or as required for fire resistance.

**10. System III: Application of Gypsum Board by Adhesive Nail-on to Wood Framing Members**

10.1 Except as herein modified, application shall be in conformance with Section 8.

10.2 Surfaces of gypsum board and framing to receive the adhesive shall be free of dust, dirt, grease, or any other foreign matter that cause bond loss. Foreign matter shall be removed.

10.3 A bead of adhesive 3/8 in. (9.5 mm) in diameter shall be applied to the face of all wood framing members, except plates, that support the gypsum board. The adhesive shall be spread to an average width of 3/4 in. (19 mm) and an average thickness of 1/16 in. (1.6 mm). See Fig. 4 for application patterns.

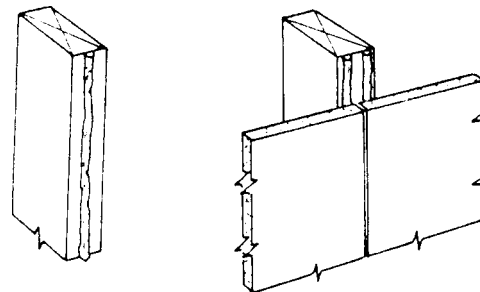

**FIG. 4 Adhesive Application Patterns**



10.3.1 Where a joining of two adjacent pieces of gypsum board occurs on a framing member, two parallel beads of adhesive shall be applied, one near each edge of the framing member.

10.4 Adhesive shall be applied to no greater area than can be covered with gypsum board within the “open time.”

NOTE 6—“Open time” is the time period available for working with certain adhesives before they set in accordance with the adhesive manufacturer’s specification.

10.5 *Fastener Spacing:*

10.5.1 If the properties of the adhesive ensure bridging between the gypsum board and the wood framing, nailing shall not be required in the field of the board for walls. In such cases, perimeter nailing, 16 in. (406.4 mm) on centers, shall be required.

10.5.2 When the properties of the adhesive are such that there is no positive bridging between the gypsum board and the wood framing, either temporary field nailing or temporary bracing shall be used to ensure contact between the gypsum board, the adhesive, and the wood framing, until the adhesive develops a bond.

10.5.3 Unless specified otherwise by the adhesive manufacturer, fastener spacing shall be in accordance with Table 6.

**11. System IV: Semi-Solid Gypsum Board Partitions**

11.1 *Installation:*

11.1.1 Runners or studs shall be installed where required to provide support at exterior walls, partition junctions, terminals, external corners, door frames, and at other locations.

11.1.2 The gypsum board face panels and studs shall be positioned vertically.

11.1.3 The gypsum studs shall be laminated to face panels not more than 24 in. (609.6 mm) on centers and located at face panel vertical joints and at vertical centerline of panel.

11.1.4 Gypsum studs shall be laminated to face panels prior to erection or as erection of partition proceeds. A starter face panel shall be erected vertically at an intersecting wall. The starter panel shall be plumb and secured to the floor, the ceiling, and the vertical runners.

11.1.5 The next face panel adjacent to the starter panel shall be erected by butting its edge and end firmly to the starter panel and the ceiling. Erection of the face panels shall continue by laminating exposed faces of gypsum studs as work progresses.

11.1.6 Openings in partitions for doors and electrical outlets shall be carefully and accurately marked and cut.

11.1.7 Laminating compounds or adhesives shall be of a consistency and volume that will cover approximately three-fourths of the stud surface after lamination.

11.1.8 Type G screws shall be used to ensure a continuous bond between face panels and studs, and shall be spaced not more than 36 in. (914 mm) on centers.

11.1.9 Openings or changes in direction of partitions shall be reinforced with additional studs laminated in place at the following locations:

11.1.9.1 *External Corners*—Between the face panels in the corner opposite vertical runners.

11.1.9.2 *Abutting Walls*—Between the face panels of a partition to reinforce junction of an abutting wall.

11.1.9.3 *Door Openings*—Locate a vertical stud within 3 in. (76.2 mm) of door frame for reinforcement, and place a stud horizontally over the door header.

**12. System V: Solid Gypsum Board Partitions**

12.1 Non-load bearing solid partition consisting of gypsum coreboard faced on each side with gypsum board panels.

12.2 *Installation:*

12.2.1 Floor and ceiling runners shall be installed according to the layout and shall be secured not more than 24 in. (610 mm) on centers. Vertical runners shall be installed where specified in 11.1.1.

12.2.2 For partitions located parallel to and between ceiling members, steel or wood blocking not more than 24 in. (609.6 mm) on centers shall be provided to fasten ceiling runners prior to erection of ceiling.

12.2.3 Face panels shall be attached to runners at not more than 24 in. (609.6 mm) on centers.

12.2.4 Coreboard shall be installed prior to the installation of the face panel. Coreboard shall be attached not more than 24 in. (610 mm) on centers to the steel angles when steel angles are used as runners. When steel channels are used as runners to secure coreboard, attachment shall not be required.

NOTE 7—Combinations of wood and steel channels or angles will vary the installation procedure.

12.2.5 The adhesive shall be applied to the back surface of the face panels or the face of the coreboard as described for two-ply gypsum board construction (see Section 9).

12.2.6 The face panels shall be laminated to the core with sufficient pressure to ensure bonding. The joints of the face panels and core shall be staggered. To ensure the bond between face panels and core, fasteners shall be permitted.

**13. System VI: Application of Gypsum Board with Adhesive to Interior Masonry or Concrete Walls**

13.1 When applying gypsum board to monolithic concrete, brick, or concrete block, the adhesive shall be applied directly to the back of the gypsum board or on the wall in continuous beads not more than 12 in. (304.8 mm) on centers or daubs spaced not more than 12 in. (304.8 mm) on centers each way.

13.1.1 Beads shall be not less than 3/8 in. (9.6 mm) in diameter to provide a continuous bond between the gypsum board and the wall surface.

**TABLE 6 Fastener Spacing with Adhesive or Mastic Application and Supplemental Fastening**

Framing Member Spacing, in. (mm)	Ceilings, in.		Partitions Load Bearing, in.		Partitions Nonload Bearing, in.	
	Nail	Screw	Nail	Screw	Nail	Screw
On Centers						
16 (406.4)	16	16	16	24	24	24
24 (609.6)	12	16	12	16	16	24



13.1.2 Daubs shall be 2 to 3 in. (50.8 to 76.2 mm) in diameter.

13.2 The gypsum board shall be positioned 1/8 in. (3.2 mm) from the floor and provide a tight fit at abutting edges or ends. The gypsum board shall not be slid on the adhesive. Mechanical fasteners, or temporary bracing, shall be used to support gypsum board until adhesive sets.

13.3 Delay the joint treatment until the gypsum board is firmly bonded.

13.4 Foil-backed gypsum board shall not be used for direct adhesive application.

13.5 Direct adhesive application shall be used only on interior masonry or concrete walls above grade, or the inside of exterior masonry cavity walls with 1-in. (25.4 mm) minimum width cavity between the inside and outside masonry for the full height of the above grade surface to receive gypsum board. Surfaces to which gypsum board is to be adhesively attached shall be free of any foreign matter, projections, or depressions that will impair the bond.

**14. System VII: Application of Gypsum Board to Rigid Plastic Foam Insulation**

14.1 *Application of Furring and Plastic Foam Insulation to Masonry and Concrete Walls:*

14.1.1 Rigid foam insulation shall be applied to the masonry or concrete in accordance with the foam manufacturer’s specifications.

14.1.2 Furring strips or special metal furring members shall be attached by mechanical means to the masonry or concrete wall surface either before or after application of the insulation, depending on the system used. The furring members shall be installed in accordance with Table 1 and at gypsum board terminations above suspended ceilings, around doors, windows, or other openings, and for cabinet and fixture attachment.

14.2 The gypsum board shall be applied to furring as described in 8.4.1 or 8.5. The mechanical fasteners shall not penetrate completely to the masonry or concrete.

**15. System VIII: Application of Gypsum Board to Steel Framing and Furring**

15.1 Screw application shall be applied in accordance with 7.1.6.

15.1.1 Screws shall be of sufficient length so that the threaded portion shall penetrate not less than 3/8 in. (9 mm) into the framing members.

15.1.2 Where resilient furring channels are used, the screws used to attach gypsum board to the furring channels shall not contact the framing.

15.2 *Framing Spacing*—Maximum spacing of steel framing and furring for screw application shall be as specified in Table 1 for single-ply gypsum board and as specified in Tables 3 and 4 for two-ply gypsum board.

15.2.1 Installation of steel framing shall be in accordance with Specifications C 754 or C 1007.

**15.3 Screw Spacing:**

15.3.1 Screw spacing for single-ply gypsum board and face ply of two-ply gypsum board with no adhesive shall be in accordance with 8.5.

15.3.2 Screw spacing for parallel applied base-ply of two-ply gypsum board over steel framing with no adhesive between the plies shall be not more than 12 in. (304.8 mm) on centers along the edges of the gypsum board and 24 in. (609.6 mm) on centers into the stud or furring channel in the field of the gypsum board.

15.3.3 Screw spacing for a perpendicularly applied base-ply of two-ply gypsum board over steel framing with no adhesive between the plies shall be not less than one screw at each edge of the gypsum board at each framing member and one screw midway between the edges at each framing member.

15.3.4 Screw spacing for perpendicular or parallel applied base-ply of two-ply gypsum board over steel framing with adhesive between plies shall be not more than as specified for single-ply gypsum board in 8.5.

15.3.5 Screw spacing on ceilings for the face-ply of two-ply gypsum board over steel framing with adhesive between plies shall be the same as specified for the base-ply gypsum board in 15.3.2 and 15.3.3.

15.3.6 On wall surfaces with adhesive between the plies, the face-ply shall have only a sufficient number of screws to hold gypsum board in place.

**16. System IX: Arches and Bending Radii**

16.1 Where gypsum board is to be applied to the soffit of arches, it shall be carefully bent into place (see Table 7). If necessary, it first shall either be dampened or cut approximately 1 in. (25.4 mm) on centers on the back side. In the latter case, after the core has been broken at each cut, the gypsum board shall be applied to the curved framing member and fastened in place. At the arises of the arch (exterior or interior “corners” formed at the meeting of the adjoining angle surfaces), joint compound and joint tape or corner bead shall be applied. The tape or corner bead shall be snipped at intervals along one side so that the applied tape or corner bead conforms to the curved contour.

NOTE 8—To apply the board, place a stop at one end of the curve, then gently and gradually push on the other end of the board, forcing the center against the framing until the curve is complete.

NOTE 9—By thoroughly moistening the face and back paper and allowing the water to soak well into the core, the board will bend to still shorter radii. When the board thoroughly dries, it will regain its original hardness. Any subsequent joint treatment or decoration shall not be started until the gypsum board is thoroughly dry.

**17. System X: Application of Gypsum Board to Receive Tile by Adhesive Application**

17.1 Framing around tub enclosures and shower stalls shall maintain sufficient room to accommodate the inside lip of the tub, prefabricated receptor, shower pan, or membrane as shown in Figs. 5-7.

**TABLE 7 Bending Radii**

Gypsum Board Thickness, in. (mm)	Bent Lengthwise, ft (m)	Bent Widthwise, ft (m)
1/2 (12.7)	10 (3.05) <sup>A</sup>	—
3/8 (9.5)	7 1/2 (2.29)	25 (7.62)
1/4 (6.4)	5 (1.52)	15 (4.57)

<sup>A</sup> Bending two 1/4-in. (6.4-mm) pieces successively permits radii shown for 1/4 in. (6.4 mm).

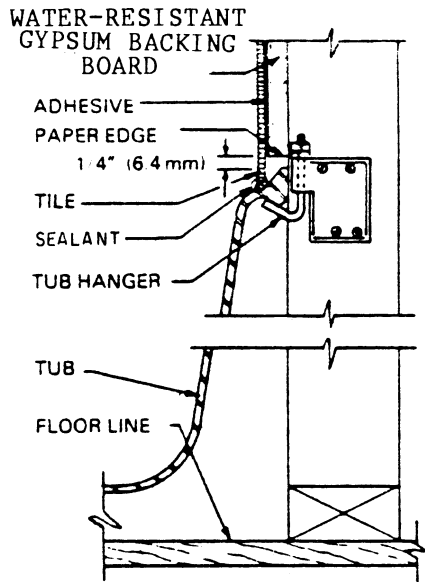

FIG. 5 Application of Gypsum Board at Bathtub Where WR Board Will Receive Ceramic Tile or Other Protective Covering

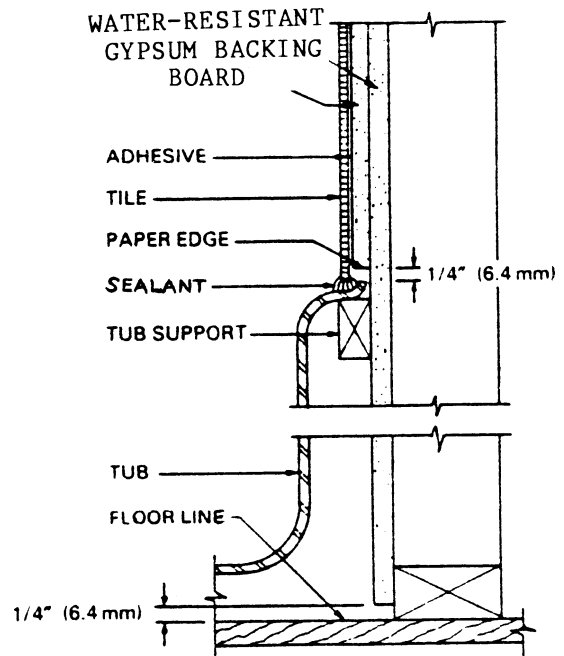

FIG. 7 Adhesive Application of Tile Over Gypsum Board

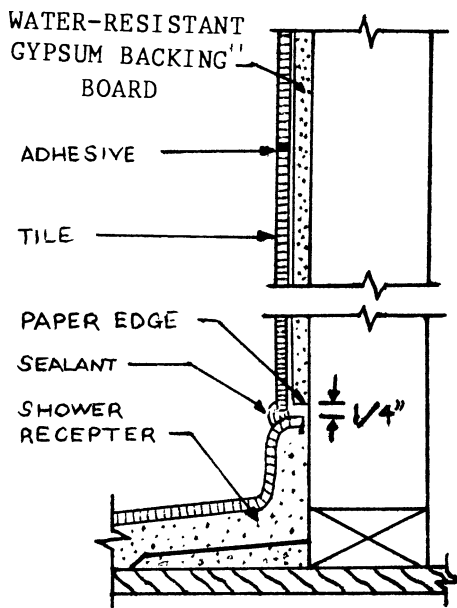

FIG. 6 Adhesive Application of Gypsum Board at Shower Where WR Board Will Receive Ceramic Tile or Other Protective Covering

NOTE 10—This will necessitate furring out from the framing members the thickness of the gypsum board to be used ( $\frac{1}{2}$  or  $\frac{5}{8}$  in. (12.7 or 15.9 mm)) less the thickness of the lip, on each wall abutting a tub receptor or subpan.

17.2 Blocking or Backing:

17.2.1 Where framing is spaced more than 16 in. (406 mm) o.c., blocking or backing shall be provided  $\frac{3}{4}$ – $1\frac{1}{4}$  in. (20–30 mm) above the top of the tub or receptor and at gypsum board horizontal joints in the area to receive tile.

17.2.2 Interior angles shall be framed or blocked to provide solid backing for interior corners.

17.2.3 Blocking, headers, or supports shall be provided to support the tub and other plumbing fixtures and to receive soap dishes, grab bars, towel racks, and similar items.

17.3 General:

17.3.1 Water-resistant gypsum backing board shall be used as a base for adhesive application of ceramic or plastic wall tile in wet areas such as tub and shower enclosures. Either regular gypsum board or water-resistant gypsum backing board shall be used as a base for tile in other areas. Water-resistant gypsum backing board and regular gypsum board shall not be used in extremely critical areas such as saunas, steam rooms, or gang shower rooms. Foil-backed gypsum board shall not be used as a base for tub or shower enclosures. Water-resistant gypsum board used as a base for tile or wall panels in tub and shower enclosures shall not be applied directly over a vapor retarder.

17.3.1.1 Gypsum board shall not be used where there will be direct exposure to water or continuous high humidity conditions such as are found in saunas, steam rooms, gang shower rooms, or indoor pools.

17.3.1.2 Foil-backed gypsum board shall not be used as a base for tub or shower enclosures.

17.3.1.3 Water-resistant gypsum backing board used as a base for tile or wall panels in tub and shower enclosures shall not be applied directly over a vapor retarder.

17.3.1.4 Ceiling framing spacing for water-resistant gypsum backing board  $\frac{1}{2}$  in. (12.7 mm) thick applied to ceilings shall be not more than 12 in. (305 mm) on centers.

17.3.1.5 Ceiling framing spacing for water-resistant gypsum backing board  $\frac{5}{8}$  in. (15.9 mm) thick applied to ceilings shall be not more than 16 in. (406 mm) on centers.

NOTE 11—Asphalt-impregnated felt is not considered a vapor retarder.

17.3.2 All multiple plies of gypsum board in wet areas shall be attached with mechanical fasteners.

17.3.3 Waterproof receptors, pans, or sub-pans shall have an upstanding lip or flange that shall be a minimum of 1 in. (25.4 mm) higher than the water dam or threshold contained in the entry way to the shower.

17.4 Installation:

17.4.1 Water-resistant gypsum backing board shall be applied with the factory edge spaced not less than 1/4 in. (6.4 mm) above the lip of the receptor, tub, or sub-pan. Shower pans, receptors, or tubs shall be installed prior to the erection of the water-resistant gypsum backing board.

17.4.2 Water-resistant gypsum backing board shall be attached by nails or screws spaced not more than 8 in. (203.2 mm) on centers. When ceramic tile more than 3/8 in. (9.5 mm) thick is to be applied, the nail or screw spacing shall be not more than 4 in. (101.6 mm) on centers.

17.4.3 Where treatment of water-resistant gypsum backing board joints under tile in wet areas (tub and shower enclosures) is required, the compound and application thereof, shall be as required by the joint compound manufacturer for this specific use, or shall be protected from penetration of moisture or water (see X4.2).

17.4.4 All cut edges and openings around pipes and fixtures shall be caulked flush with water-resistant flexible sealant.

17.4.5 Certain fire or sound-rated gypsum board assemblies require the installation of an additional layer of water-resistant gypsum backing board (see Fig. 7). A 1/4 in. (6.4 mm) clearance shall be maintained between the wallboard and tub rim, or shower base, as shown in Figs. 6 and 7.

NOTE 12—For installation of ceramic tile to gypsum boards, see X4.3.

18. System XI: Exterior Application of Gypsum Wallboard and Exterior Gypsum Soffit Board

18.1 Where gypsum wallboard or exterior gypsum soffit board is used for ceilings of carports, open walkways, porches, and soffits of eaves that are horizontal or inclined downward away from the building, the gypsum board shall be either 1/2 or 5/8 in. (12.7 or 15.9 mm) in thickness. Framing shall be not more than 16 in. (406 mm) on centers for 1/2-in. (12.7-mm) thick gypsum board and not more than 24 in. (610 mm) on centers for 5/8-in. (15.9-mm) thick gypsum board. The gypsum board shall be installed perpendicularly in accordance with the foregoing specifications except as herein modified.

18.2 Suitable fascia and molding shall be provided around the perimeter to protect the gypsum wallboard and exterior gypsum soffit board from direct exposure to water. Unless protected by metal or other water stops, the edges of the gypsum wallboard and exterior gypsum soffit board shall be placed not less than 1/4 in. (6.4 mm) away from abutting vertical surfaces. (See Figs. 8-10.) Joints and fastener heads shall be treated as specified in X3.6.

18.3 Exposed surface of gypsum board and exterior gypsum soffit board shall be treated as specified in X3.6.

18.4 Adequate ventilation shall be provided for the space immediately above installations (see Appendix X2).

19. System XII: Floating Interior Angles

19.1 Gypsum board shall be applied to ceiling first. (See Figs. 11-13.)

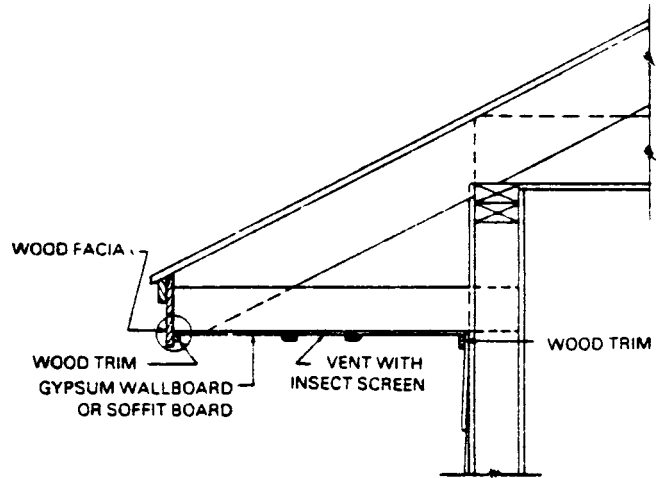

FIG. 8 Frame Wall

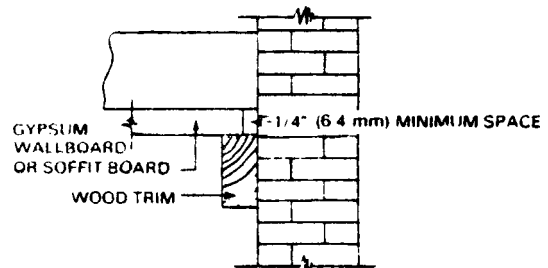

FIG. 9 Masonry Wall

19.1.1 The floating angle method of application minimizes the possibility of fastener popping in areas adjacent to the wall and ceiling intersections for single-ply or two-ply applications of gypsum board to wood framing.

19.2 Ceilings—The first fastener into each ceiling framing member framed perpendicular to the intersection shall be located 7 in. (117.8 mm) out from the wall intersection for single nailing, and 11 to 12 in. (279.4 to 304.8 mm) for double nailing, or screw application.

19.3 Walls—Gypsum board shall be applied on walls so as to provide support for the floated edges of the ceiling gypsum board. The top fastener into each vertical framing member shall be located 8 in. (203.2 mm) down from the ceiling intersection for single nailing, and 11 to 12 in. (279.4 to 304.8 mm) for double nailing, or screw application. (See Figs. 11 and 12.) At wall vertical angles, the over-lapping board shall be applied so as to bring the back of the underlying board into firm contact with the face of the framing member behind it. Fasteners shall be omitted from the underlying board at the intersection. (See Fig. 13.)

20. System XIII: Control (Expansion) Joints

20.1 Control (expansion) joints shall be installed in ceilings exceeding 2500 ft<sup>2</sup> (232 m<sup>2</sup>) in area and in partition, wall and wall furring runs exceeding 30 ft (9.1 m). The distance shall not be more than 50 ft (15.2 m) between ceiling control (expansion) joints in either direction. A control (expansion) joint shall be installed where ceiling framing or furring changes direction. The distance between control (expansion) joints in

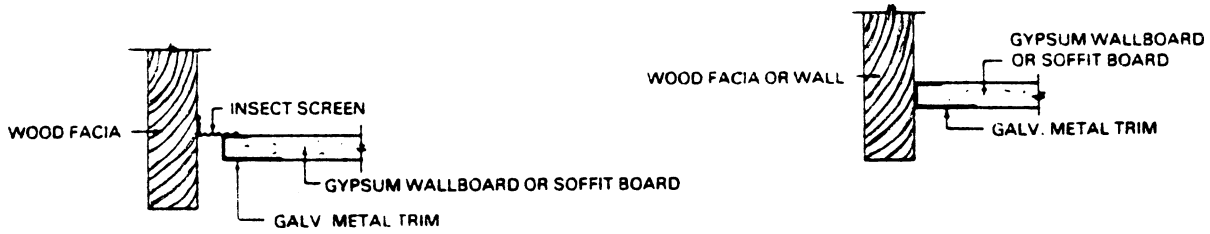

FIG. 10 Alternate Facia Details

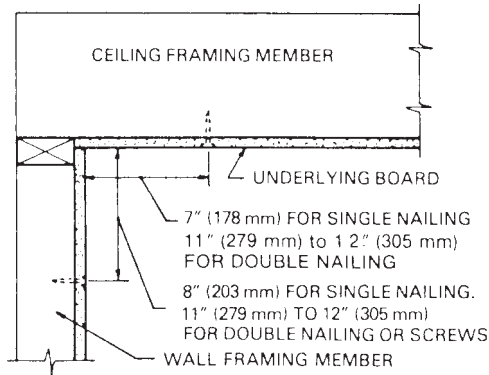

FIG. 11 Vertical Section, Ceiling Framing Member Perpendicular to Wall

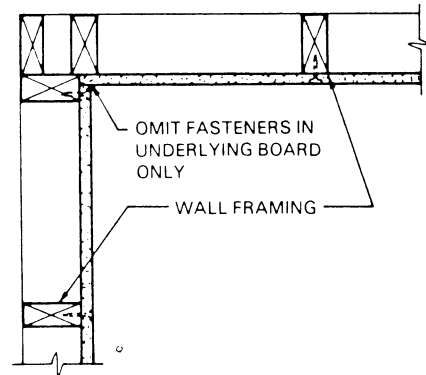

FIG. 13 Horizontal Section Through Interior Vertical Angle

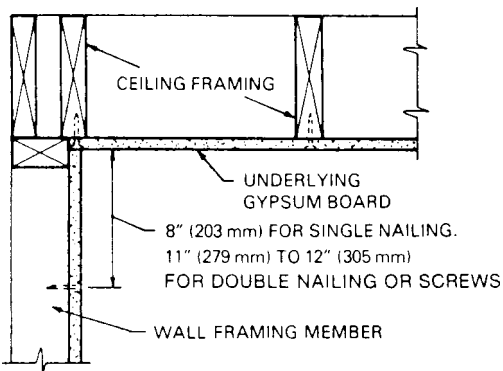

FIG. 12 Vertical Section, Ceiling Framing Parallel to Wall

walls or wall furring shall not be more than 30 ft. (9.1 m). A control (expansion) joint shall be installed where a control (expansion) joint occurs in the base exterior wall. Wall or partition height door frames shall be considered a control joint.

**21. System XIV: Foil-Backed Gypsum Board**

21.1 The application of foil-backed gypsum board shall conform to the specifications for the application of gypsum board. The reflective surface shall be placed against the face of the framing members. Foil-backed gypsum board shall not be used in the following areas:

- 21.1.1 As a backing material for tile in wet areas.
- 21.1.2 For the second ply on two-ply laminating systems.
- 21.1.3 For laminating directly to masonry or concrete.
- 21.1.4 In conjunction with electric heating cables.

**22. Finishing of Gypsum Wallboard**

22.1 *General:*

22.1.1 Compound for taping and finishing shall be either drying or setting types. Drying and setting type compounds shall not be mixed together unless specified otherwise by the joint compound manufacturer.

22.1.2 When applied, the compounds shall be of a chemical composition compatible with previous and successive coats.

22.1.3 No finishing operation shall be started until the interior temperature has been maintained at a minimum of 50°F (10°C) for a period of at least 48 h and thereafter until the compounds have completely dried.

22.1.4 When two-ply application is used with adhesives between plies, precautions shall be taken to ensure that the adhesive is thoroughly dried before any decorative finish is applied.

22.1.5 Adequate and continuous ventilation shall be provided to ensure proper drying and hardening of the compounds.

**22.2 Surface Preparation:**

22.2.1 Dirt, oil, and other materials that cause a lack of bond shall be removed from all surfaces to receive joint compound.

22.2.2 All dents, gouges, recesses, or other depressions shall be filled with compound to produce a monolithic surface.

**22.3 Taping:**

22.3.1 Joint tape and joint compounds shall be applied using tools designed for this work and the compounds being used. Such tools include hand-held broad knives, trowels, or mechanical tools.

22.3.2 The tape shall be applied by applying joint compound to the joint (buttering), pressing in the tape and wiping off the excess compound, or by mechanical tools designed for this purpose. Sufficient compound shall be left under the tape to provide a bond of the tape to the gypsum board.

**22.4 Finishing:**

22.4.1 Finishing compound and all-purpose compound shall be applied with tools of sufficient width to extend a minimum



of 3½ in. (89 mm) beyond both sides of the center of the joint tape. The compound shall be drawn down to a level plane. After the compound has dried, the surface shall be sanded (see 22.5) or wiped with a dampened sponge to eliminate high spots and excessive compound.

22.4.1.1 Coats of non-setting type compounds shall be thoroughly dry before sanding or the application of additional coats.

22.4.1.2 Additional coats of compounds shall be applied over setting-type compound either after it has set or, after it has set and dried.

22.4.2 Additional coats of finishing compound shall be applied with tools that will feather the material not less than 6 in. (152 mm) beyond both sides of the center of the joint tape. The compound shall be drawn down to a level plane, leaving a monolithic surface.

NOTE 13—A smooth surface is achieved by lightly sanding or wiping the joint compound with a dampened sponge. Do not raise the nap of the paper of the gypsum board (see 22.5). See Appendix X3.

22.4.3 Fastener heads shall be covered (spotted) with successive coats of joint compound. The first coat shall be taping or all-purpose compound; the additional coats shall be finishing or all-purpose compound.

22.4.4 All cut-outs shall be back filled with the compound used for taping and finishing so there is no opening larger than ¼ in. (6 mm) between the gypsum board and the penetrating element.

22.4.5 Accessories shall be finished with successive coats of joint compound. This surface, when completed, shall be flush with the surface of the gypsum board. The first coat over the flanges shall be taping or all-purpose compound; the additional coats shall be finishing or all-purpose compound.

22.4.6 The skim coat of joint compound or a material manufactured especially for this purpose shall be applied to the entire surface where Level 5 is required.

22.4.7 All tools and containers shall be kept clean and free from foreign materials.

22.4.8 Only potable water shall be used for mixing powder compounds or to thin premixed materials.

22.5 Approved protective respirators shall be worn when mixing dry compound or sanding.

#### 22.6 Levels of Finish:

NOTE 14—The required level or extent of finishing of gypsum wall-board joints, fastener heads, and overall surface can vary with the location in a structure and the intended type of decoration. This section describes various levels of finishing, that is, number of applications of joint compound, sanding or other finishing techniques; the recommendations of manufacturers may vary from what is specified herein and as such are not part of these specifications. The relationship of levels of finishing with location and intended decoration is described in Appendix X8.

##### 22.6.1 Level 0:

22.6.1.1 No taping, finishing or corner beads are required.

##### 22.6.2 Level 1:

22.6.2.1 All joints and interior angles shall have tape embedded in joint compound. Surface shall be free of excess joint compound. Tool marks and ridges shall be acceptable.

##### 22.6.3 Level 2:

22.6.3.1 All joints and interior angles shall have tape embedded in joint compound and shall be immediately wiped with a joint knife or trowel leaving a thin coating of joint compound over all joints and interior angles. Fastener heads and accessories shall be covered with a coat of joint compound. Surface shall be free of excess joint compound. Tool marks and ridges are acceptable.

22.6.3.2 Joint compound applied over the body of the tape at the time of tape embedment shall be considered a separate coat of joint compound and shall satisfy the conditions of this level.

##### 22.6.4 Level 3:

22.6.4.1 All joints and interior angles shall have tape embedded in joint compound and shall be immediately wiped with a joint knife or trowel leaving a thin coating of joint compound over all joints and interior angles. One additional coat of joint compound shall be applied over all joints and interior angles. Fastener heads and accessories shall be covered with two separate coats of joint compound. All joint compounds shall be smooth and free of tool marks and ridges (see 22.4.1.1). The prepared surface shall be covered with a drywall primer prior to the application of the final decoration.

##### 22.6.5 Level 4:

22.6.5.1 All joints and interior angles shall have tape embedded in joint compound and shall be immediately wiped with a joint knife or trowel leaving a thin coating of joint compound over all joints and interior angles. Two separate coats of joint compound shall be applied over all flat joints. One separate coat of joint compound shall be applied over interior angles. Fastener heads and accessories shall be covered with three separate coats of joint compound. All joint compounds shall be smooth and free of tool marks and ridges (see 22.4.1). The prepared surface shall be covered with a drywall primer prior to the application of the final decoration.

##### 22.6.6 Level 5:

22.6.6.1 All joints and interior angles shall have tape embedded in joint compound and shall be immediately wiped with a joint knife or trowel leaving a thin coating of joint compound over all joints and interior angles. Two separate coats of joint compound shall be applied over all flat joints. One separate coat of joint compound shall be applied over interior angles. Fastener heads and accessories shall be covered with three separate coats of joint compound. A thin skim coat of joint compound shall be trowel-applied to the entire surface. Excess compound is immediately sheared off, leaving a film of skim coating compound completely covering the paper. As an alternate to a skim coat, a material manufactured especially for this purpose shall be applied. The surface shall be smooth and free of tool marks and ridges (see 22.4.1.1).

## 23. Delivery, Identification, Handling, and Storage

23.1 All materials shall be delivered in the original factory sealed, unopened packages, containers, or bundles bearing the brand name, applicable standard designation, and the name of the manufacturer, or the supplier for whom the product is manufactured.

23.2 All materials shall be kept dry. Where gypsum board is stored outside, it shall be off the ground, properly supported on a level platform and fully protected from the weather or direct

sunlight exposure. Adequate ventilation shall be provided to prevent condensation.

23.3 Gypsum board shall be neatly stacked flat, not on its end or edge, to prevent toppling, sagging or damage to the ends, edges, and surfaces.

NOTE 15—Gypsum board stacked on edge or end is unstable and presents a serious hazard in the workplace should it accidentally topple.

23.4 Ready mixed and dry compounds which have been mixed with water shall be stored at temperatures above freezing or temperatures specified by the manufacturer.

## 24. Keywords

24.1 ceiling; gypsum; wallboard; walls

## APPENDIXES

### (Nonmandatory Information)

#### X1. GENERAL INFORMATION

##### INTRODUCTION

These Appendixes give general information and also suggestions for inclusions to be made elsewhere by the specifier. They are not a part of this specification.

X1.1 Scaffolding shall be constructed and maintained in strict conformity with applicable laws and ordinances.

X1.2 This work shall be properly coordinated with the work of other trades.

X1.3 Gypsum board shall be protected from the elements of weather before, during, and after application.

#### X2. VENTILATION ABOVE GYPSUM BOARD CEILINGS

X2.1 Adequate ventilation of attics or similar unheated spaces above gypsum board systems is essential to the performance of these systems and shall be designed and provided by

others per ASHRAE Fundamentals Handbook or applicable building code.

#### X3. JOB APPLIED DECORATION

X3.1 Prolonged exposure of gypsum board to sunlight may cause problems in decoration.

X3.2 With the joints and fastener head depressions treated as specified in Section 10, interior walls of gypsum board may be decorated in any of the popular variety of finishes, such as texture or stipple, flat paint or flat enamel paint, wall paper, or vinyl wall coverings.

X3.3 Because the porosity and texture of the gypsum board differs from that of the joint treatment, the surface shall be primed and sealed as may be required for the subsequent finish coats.

X3.4 In rooms where high humidity may be encountered, such as the kitchen, bath, or utility room, a flat or semigloss enamel finish is recommended.

X3.5 Care should be exercised in the selection of primer and sealer paints to make sure they will perform satisfactorily, and fulfill the following functions:

X3.5.1 Equalize variations of suction over the entire surface.

X3.5.2 Provide a bonding surface or “tooth” for the paint to be applied.

X3.5.3 Avoid nap raising.

X3.6 Before applying the sealer, remove all loose dirt and dust by brushing with a soft brush or by rubbing with a dry cloth. Be sure the joint treatment is thoroughly dry before any application of sealer or paint.

X3.7 In applying primers or sealers, apply sufficient quantity to assure that the surface is completely covered. Follow the manufacturer’s printed directions and do not over thin. It is good practice to tint the sealer to approximately the shade of the finish coat. This will lead to better results in the finished job.

X3.8 In all cases where deep tones are to be used in the finish paint, best results will be achieved if the surface is first sealed. More than one coat of sealer may be necessary. Each coat must be thoroughly dry before applying another.

X3.9 Under normal atmospheric conditions, a waiting period of 12 to 18 h after application of primer-sealer should be

observed before decoration is applied. In rainy, humid, and cold weather, a longer waiting period; sometimes as long as 36 to 48 h; may be necessary to make certain the sealer coat is absolutely dry.

X3.10 Exposed surfaces of gypsum board, as specified in Section 10 shall be painted with not less than two coats of exterior paint.

#### **X4. APPLICATION OF SURFACING MATERIALS AND CAULKING**

X4.1 Caulk all cut edges and openings around pipes and fixtures flush with waterproof, nonhardening caulking compound or Type I adhesive complying with ANSI A 136.1.

X4.2 Wall tile shall be used in combination with adhesive to protect the gypsum board and any water sensitive materials if present (such as joint compound) from penetration of moisture or water. Responsibility for performance of completed installation shall rest with the surface materials manufacturer or with the tile applicator.

X4.3 For application of ceramic, plastic, or metal wall tile, or plastic finished rigid wall panels, or other types of surfacing materials over gypsum board in wet or dry areas, the recommendations of the manufacturer of tile, wall panel, or other surfacing materials shall be followed.

X4.4 Apply the surfacing material down to the top surface or edge of the finished shower floor, return, or tub, or install so as to overlap the top lip of receptor, sub-pan, or tub. It shall completely cover the following areas:

X4.4.1 *Over Tubs without Showerheads*—Six in. (152.4 mm) above the rim of the tub.

X4.4.2 *Over Tubs with Showerheads*—A minimum of 5 ft (1.52 m) above the rim or 6 in. (152.4 mm) above the height of the showerhead, whichever is higher.

X3.11 Where semi-gloss or high-gloss paints are required or where severe lighting conditions occur, and prior to the application of a primer, a skim coat shall be applied to the entire surface of the wallboard, including the taped joints, covered fasteners, and accessories, to reduce the absorption and texture difference between the joint compound and the face of the wallboard.

X4.4.3 *Shower Stalls*—A minimum of 6 ft (1.83 m) above the shower dam or 6 in. (152.4 mm) above the showerhead, whichever is higher.

X4.4.4 All gypsum board window sills and jambs in shower or tub enclosures shall be covered to a like height.

X4.4.5 The surfacing material shall be applied to the full specified height for a distance of at least 4 in. (101.6 mm) beyond the external face of the tub or receptor. Areas beyond an exterior corner are excluded.

X4.5 Where plastic finished rigid wall panels are used as a surfacing material, the following precautions shall be taken:

X4.5.1 The type and shape of moldings recommended by the manufacturer of the surfacing material shall be used. Recommended tub moldings shall be used at the base where the surfacing materials abut the tub, shower, floor, or curb. Such moldings shall be set in waterproof, nonhardening caulking compound.

X4.5.2 Joints shall be filled in such a manner as to leave no voids for water penetrations.

X4.5.3 A bead of adhesive shall be applied as a dam between the back surface of the finishing material and the tub or receptor to prevent any leakage of water at the joint.

#### **X5. WOOD FRAMING REQUIREMENTS**

X5.1 The following requirements should be included in the project specifications for framing and furring and are essential to provide a proper base to receive the gypsum board.

X5.2 All framing members to which gypsum board will be fastened shall be straight and true. Framing shall be in alignment and spaced not to exceed the maximum spacings shown in Table 1. Framing, bridging, and furring members shall be the proper grade for the intended use and members 2 by 4 in. nominal size or larger shall bear the grade mark of a recognized inspection agency. Framing, bridging, and furring shall be adequate to meet the design, or code loading, or both. Where there is an applicable local code, the framing shall be in accordance with the Manual for House Framing by the National Lumber Manufacturers. Supports shall be provided as necessary for the support of fixtures.

X5.3 When gypsum board is nailed to wood cross furring on ceilings, these furring members shall have a minimum cross section of 1½ by 1½ in. (38.1 by 38.1 mm) actual size and be spaced in accordance with 9.2 and 9.3. Where screw application is used, the furring member may be ¾ in. by 2½ in. (19.1 by 63.5 mm) actual size.

X5.4 Where wood furring is used over masonry or concrete, fasteners should be of a length that does not come into contact with the masonry surface.

X5.5 Insulating blankets or flanges of blankets shall not be applied over framing members that are to receive gypsum board.

X5.6 Foil-backed gypsum board may be used where a vapor retarder is required.

## X6. PRECAUTIONS TO MINIMIZE POTENTIAL OF SAGGING

X6.1 Ensure framing spacing is adequate for thickness of board to be used. Ensure board is applied perpendicular to framing.

X6.2 Determine that excessive weight of insulation will not be added.

X6.3 Control the relative humidity within the structure by providing adequate ventilation before, during, and after board application. Watch for pouring of basement floors after board application.

X6.4 In cold weather, maintain inside temperature between 50°F (10°C) and 70°F (20°C). Where portable heaters are used, make sure to remove the extra humidity they produce.

X6.5 Ensure the gypsum board is thoroughly dry and at

ambient temperature before application.

X6.6 Ensure joint treatment is thoroughly dry before applying any decoration.

X6.7 Ensure that primer and paint coats are dry before the application of successive coats.

X6.8 Where hand or spray-applied water-based texture finishes are to be used on gypsum board ceilings under this specification either (1) ½ in. (12.7 mm) Gypsum Ceiling Board (see Specification C 1395/C 1395M) shall be used perpendicular to framing not more than 24 in. (610 mm) on center, or (2) other gypsum boards shall be used perpendicular to framing and board thickness shall be not less than ½ in. (12.7 mm) thick for 16 in. (406 mm) on center framing and not less than ⅝ in. (15.9 mm) thick for 24 in. (610 mm) on center framing.

## X7. ELECTRIC RADIANT HEATING SYSTEMS FOR GYPSUM BOARD CEILINGS

X7.1 The application of gypsum board under this specification shall be performed in accordance with Specification C 840, except as herein modified.

X7.2 Gypsum boards shall have no less thickness than that specified for perpendicular application for the ceiling framing spacing. Both layers shall be applied perpendicularly to framing members. Attachment shall be as required in Section 9.

X7.3 Electric heating cables shall be securely attached to gypsum board in accordance with the recommendations of the cable manufacturer and the National Electrical Code by other trades.

X7.4 Cables shall be parallel to and between framing members with at least 1¼-in. (31.8-mm) clearance from center of framing member on each side so that at least 2½-in. (63.5-mm) wide unobstructed strip is provided under each framing member.

X7.5 Cables shall cross framing members only at ends of ceiling 4 to 6 in. (101.6 to 152.4 mm) from the wall. There shall be at least a 4 in. (101.6 mm) space completely around the perimeter of each ceiling that is clear of cables. Cables shall be kept at least 8 in. (203.2 mm) clear of all openings.

X7.6 All inspections and testing of the heating system shall be completed before application of the noninsulating filler.

X7.7 Under no operating conditions shall the gypsum board core be exposed to a temperature exceeding 125°F (51.7°C) unless otherwise specifically recommended by the gypsum board manufacturer.

X7.8 Complete embedding of the heating cable is necessary. The area between the heating cables shall be filled with a nonshrinking, noninsulating filler that shall be leveled.

X7.9 If a face layer of gypsum board is to be applied then the nails or screws around the perimeter of the ceilings shall be spaced 8 to 10 in. (203.2 to 254.0 mm) away from the wall to prevent striking the heating elements where they cross the framing members.

X7.9.1 All joints and heads of fasteners shall be finished in accordance with the recommendations of the gypsum board manufacturer. Allow a minimum of one week with good drying conditions and two weeks in cold conditions before operating the heating system.

X7.10 If gypsum board is not used as a finish, a special spray texture for radiant heat ceilings may be applied.

X7.11 *Design Data:*

X7.11.1 It is the responsibility of the architect to prepare and correlate complete plans and specifications.

X7.11.2 It is the responsibility of the heating engineer to properly design the radiant heating system to work effectively with these materials.

X7.11.3 The data in Table X7.1 are recommended for use in calculating the heat transmission coefficient (*U*) for gypsum board constructions.

X7.12 *Decoration:*

**TABLE X7.1 Thermal Conductivity Values**

Thickness, in. (mm)	Conductance <i>C</i>		Resistance <i>R</i>		<i>I/C</i>
	Btu/h · ft <sup>2</sup> · °F	W/m <sup>2</sup> k	°F · h · ft <sup>2</sup> /Btu	k · m <sup>2</sup> /w	
⅜ (9.5)	3.10	17.6	0.32	0.057	
½ (12.7)	2.22	12.6	0.45	0.079	
⅝ (15.9)	1.78	10.1	0.56	0.099	
1 (25.4)	1.20	6.8	0.83	0.147	



X7.12.1 Decoration of the finished work, including sizing or sealing shall not proceed until the heating system has been test operated for a minimum of 24 h.

X7.12.2 The heating system should then be turned off and allowed to cool before decorating.

X7.12.3 Where texture finishes are used, such finishes must be allowed to thoroughly set or dry prior to the operation of the heating system.

## X8. LEVELS OF FINISH

NOTE X8.1—Joint compounds used to conceal the joints and fastener heads can vary in density and surface character from the adjacent wallboard surface. Terms such as “industry standard” or “workman-like finish” are often used but not specific and can lead to subjective interpretation.

The architect, general contractor and owners frequently anticipate or expect a higher level of finish than the sub-contractor can determine from the specifications that are furnished for the bid process.

Reasons for specifying levels are: (1) many building are designed with walls and partitions abutting window mullions, long hallways, or atriums with large surface areas flooded with artificial and natural lighting; (2) paints and painting methods have changed over the years with wider use of spray equipment and reduce solids in paint; and (3) differences in absorption and drying, shrinkage of the compound, tool marks and ridges in the compound, or scuffing or raising of the nap of the face paper may all, or in part, combine to emphasize visual differences.

It is recommended that the painting specification provide for proper treatment to ensure uniform absorption over the entire surface. Any special finish such as gloss, which demands a more stringent requirement than the standard surface provides, should be specifically pointed out in the design process.

### X8.1 *Level 0:*

X8.1.1 As stated, there is no finish required. To be used in temporary construction or whenever the final finish level has not been determined.

X8.1.2 Also could be used where non-predecorated panels will be used in demountable type partitions which are to be painted as a final finish.

### X8.2 *Level 1:*

X8.2.1 Frequently used in plenum areas above ceilings, in attics, in areas where the assembly would generally be concealed, or in building service corridors and other areas not normally open to public view. Some degree of sound and smoke control is provided; in some geographic locations referred to as fire-taping. Where a fire resistance rating is required for gypsum board assembly, details of construction shall be in accordance with reports of fire tests of assemblies that have met the requirements of the fire rating imposed. Accessories optional at specifier discretion in corridors and other areas with pedestrian traffic. Tape and fastener heads need not be covered with a joint compound.

### X8.3 *Level 2:*

X8.3.1 May be used when Water Resistant Gypsum Backing Board, Specification C 630, is used as a substrate, or in garages, warehouse storage, or other similar areas where surface appearance is not of primary concern.

### X8.4 *Level 3:*

X8.4.1 Used in appearance areas that are to receive heavy texture (spray or hand applied) finishes before final painting. Should not be used under smooth painted surfaces.

X8.4.2 The prepared surface shall be coated with a drywall primer prior to the application of final finishes.

### X8.5 *Level 4:*

X8.5.1 This method should be used where wallcoverings, flat paints, or light textures are specified.

X8.5.2 The prepared surface shall be coated with a drywall primer prior to the application of final finishes. Release agents for wall coverings are specifically formulated to minimize damage if coverings are subsequently removed.

X8.5.3 The weight texture and sheen level of the wall-covering selected should be taken into consideration when specifying wallcoverings over this level of drywall treatment. Joints and fasteners must be sufficiently concealed if the material is lightweight, contains limited patterns, has a glossy finish or any combination of these areas. Unbacked vinyls are not recommended.

X8.5.4 In critical lighting areas, flat paints applied over light textures tend to reduce joint photographing. Gloss, semi-gloss and enamel paints are not recommended over this level of finish.

### X8.6 *Level 5:*

X8.6.1 The highest quality finish is the most effective method to provide a uniform surface and minimize the possibility of joint photographing and of fasteners showing through the final decoration.

X8.6.2 This level of finish is required where gloss, semi-gloss, or enamel flat paints are specified or where critical lighting conditions occur.

#### X8.6.3 *Skim Coating with Joint Compound*

X8.6.3.1 A Level 5 gypsum board finish consists of joints finished with joint tape set in joint compound followed by a specified number of additional coats of compound over the tape, joint compound applied all over fastener heads and accessories, then the application of a “skim coat” of joint compound over the entire surface.

X8.6.3.2 A skim coat of joint compound is intended to conceal small imperfections in joints and on the surface of the gypsum board, smooth the texture of the paper, minimize differences in surface porosity, and create a more uniform surface to which the final decoration can be applied.

X8.6.3.3 A “skim coat” is essentially a “film” of joint compound and is not a readily measurable thickness. There is no specific mil thickness that constitutes a proper “skim coat.”

X8.6.3.4 Section 22.6.6.1 describes a “skim coat” as being “trowl applied” with intent being that the consistency (viscosity) of the joint compound be such that it can be applied by trowl if that is the tool chosen for the task. Other tools may be used for application so long as the trowl consistency is achieved.

X8.6.3.5 The objective of the application is to achieve total coverage of the entire surface with the “skim coat.” This is typically accomplished by delivering the compound to the

surface and using a drywall broad knife to force the compound into the surface pores and imperfections while shearing excess compound from the surface.

X8.6.3.6 A “skim coat” will not approximate a plastered surface.

X8.6.3.7 Once the skim coat dries, the gypsum board paper may show through and the treated joints, filled voids, and spotted fasteners will likely be visible.

*ASTM International takes no position respecting the validity of any patent rights asserted in connection with any item mentioned in this standard. Users of this standard are expressly advised that determination of the validity of any such patent rights, and the risk of infringement of such rights, are entirely their own responsibility.*

*This standard is subject to revision at any time by the responsible technical committee and must be reviewed every five years and if not revised, either reapproved or withdrawn. Your comments are invited either for revision of this standard or for additional standards and should be addressed to ASTM International Headquarters. Your comments will receive careful consideration at a meeting of the responsible technical committee, which you may attend. If you feel that your comments have not received a fair hearing you should make your views known to the ASTM Committee on Standards, at the address shown below.*

*This standard is copyrighted by ASTM International, 100 Barr Harbor Drive, PO Box C700, West Conshohocken, PA 19428-2959, United States. Individual reprints (single or multiple copies) of this standard may be obtained by contacting ASTM at the above address or at 610-832-9585 (phone), 610-832-9555 (fax), or service@astm.org (e-mail); or through the ASTM website (www.astm.org).*