



## Standard Specification for Installation of Interior Lathing and Furring<sup>1</sup>

This standard is issued under the fixed designation C 841; the number immediately following the designation indicates the year of original adoption or, in the case of revision, the year of last revision. A number in parentheses indicates the year of last reapproval. A superscript epsilon ( $\epsilon$ ) indicates an editorial change since the last revision or reapproval.

*This standard has been approved for use by agencies of the Department of Defense.*

### 1. Scope \*

1.1 This specification covers the minimum requirements for, and the methods of application of, interior lathing and furring to receive gypsum plaster applied in accordance with Specification C 842. Other materials are not prohibited from being used provided that their physical characteristics and durability under conditions of usage are at least equal in performance to those described.

1.2 The values stated in inch-pound units are to be regarded as the standard. The metric values shown in parentheses are provided for information only.

1.3 Details of construction for a specific assembly to achieve the required fire resistance shall be obtained from reports of fire-resistance tests, engineering evaluations, or listings from recognized fire testing laboratories.

1.4 Where a specific degree of sound control is required for plastered assemblies and constructions, details of construction shall be obtained from reports of sound tests of assemblies that have met the requirements of Test Method E 492.

### 2. Referenced Documents

#### 2.1 ASTM Standards:

- A 641/A 641M Specification for Zinc-Coated (Galvanized) Carbon Steel Wire<sup>2</sup>
- C 11 Terminology Relating to Gypsum and Related Building Materials and Systems<sup>3</sup>
- C 37 Specification for Gypsum Lath<sup>3</sup>
- C 514 Specification for Nails for the Application of Gypsum Board<sup>3</sup>
- C 754 Specification for Installation of Steel Framing Members to Receive Screw-Attached Gypsum Panel Products<sup>3</sup>
- C 842 Specification for Application of Interior Gypsum Plaster<sup>3</sup>
- C 847 Specification for Metal Lath<sup>3</sup>
- C 933 Specification for Welded Wire Lath<sup>3</sup>
- C 954 Specification for Steel Drill Screws for the Applica-

<sup>1</sup> This specification is under the jurisdiction of ASTM Committee C-11 on Gypsum and Related Building Materials and Systems, and is the direct responsibility of Subcommittee C11.03 on Specifications for Application of Gypsum and Other Products in Assemblies.

Current edition approved Oct. 10, 1999. Published January 2000. Originally published as C 841 – 76. Last previous edition C 841 – 98.

<sup>2</sup> Annual Book of ASTM Standards, Vol 01.06.

<sup>3</sup> Annual Book of ASTM Standards, Vol 04.01.

tion of Gypsum Panel Products or Metal Plaster Bases to Steel Studs from 0.033 in. (0.84 mm) to 0.112 in. (2.84 mm) in Thickness<sup>3</sup>

C 1002 Specification for Steel Drill Screws for the Application of Gypsum Board or Metal Plaster Bases<sup>3</sup>

C 1007 Specification for Installation of Load Bearing (Transverse and Axial) Steel Studs and Related Accessories<sup>3</sup>

C 1032 Specification for Woven Wire Plaster Base<sup>3</sup>

D 1784 Specification for Rigid Poly Vinyl Chloride PVC Compounds and Chlorinated Poly Vinyl Chloride CPVC Compounds<sup>4</sup>

D 3678 Specification for Rigid Poly(Vinyl Chloride) (PVC) Interior-Profile Extrusions<sup>5</sup>

E 492 Method for Laboratory Measurement of Impact Sound Transmission Through Floor-Ceiling Assemblies Using the Tapping Machine<sup>6</sup>

2.2 *National Association of Architectural Metal Manufacturers Standard*

HMMA 840 Installation and Storage of Hollow Metal Doors and Frames<sup>7</sup>

### 3. Terminology

3.1 *Definitions*—For definitions relating to ceilings and walls see Terminology C 11.

3.2 *Definitions of Terms Specific to This Standard:*

3.2.1 *base coat, n*—the sum of the scratch and brown coats or the total coats in place prior to application of finish coats.

3.2.2 *contact ceiling, n*—a ceiling in which the lath is attached in direct contact with the construction above, without the use of main runners or cross furring.

3.2.3 *furred ceiling, n*—a ceiling in which the furring used for the support of the lath is attached directly to the structural members of the building.

3.2.4 *suspended ceiling, n*—a ceiling in which the main runners and cross furring are suspended below the structural members of the building.

3.2.5 *main runners, n*—the members that are attached to or

<sup>4</sup> Annual Book of ASTM Standards, Vol 08.01.

<sup>5</sup> Annual Book of ASTM Standards, Vol 08.04.

<sup>6</sup> Annual Book of ASTM Standards, Vol 04.06.

<sup>7</sup> Available from NAAMM, 8 South Michigan Avenue, Suite 1000, Chicago, IL 60603.

\*A Summary of Changes section appears at the end of this standard.

**ASTM C 841**

suspended from the construction above for the support of cross furring.

3.2.6 *cross furring, n*—furring members that are attached at right angles to the underside of the main runners or construction above for support of the lath.

3.2.7 *furring, n*—spacer strips fastened to a wall, ceiling, or planar element that create an even surface for the application of metal plaster bases or gypsum lath.

3.2.8 *primary members, n*—the members (main runners or structural supports) to which the cross furring is attached.

3.2.9 *metal plaster bases, n*—expanded metal lath, sheet metal lath, welded or woven wire lath.

3.2.10 *face side (gypsum lath), n*—the side opposite the paper cover seam laps.

3.2.11 *surface transition, n*—the change in width of a surface, usually as a result of penetrations (doors, windows) or architectural demands.

**4. Delivery of Materials**

4.1 All materials shall be delivered in the original packages, containers, or bundles bearing the brand name and manufacturer's (or supplier's) identification.

**5. Storage of Materials**

5.1 All materials shall be kept dry, preferably by being stored inside. Where necessary to be stored outside, materials shall be stacked off the ground, supported on a level platform, and protected from the weather and surface contamination.

5.2 Materials shall be neatly stacked flat with care taken to avoid damage to edges, ends, or surfaces.

**6. Materials**

6.1 Wire Specification A 641/A 641M, Class 1 coating (galvanized) soft temper.

6.1.1 *Tie Wire and Hanger Wire*—Zinc-coated (galvanized) soft-annealed steel, or a material having equivalent size,

corrosion resistance and strength. Wire diameters (uncoated) specified herein correspond with United States steel wire gage numbers as follows:

Diameter, in. <sup>A</sup>	mm	Wire Gage (U.S. Steel Wire Gage)
0.0348	0.88	No. 20
0.0410	1.04	No. 19
0.0475	1.21	No. 18
0.0540	1.37	No. 17
0.0625	1.59	No. 16
0.0800	2.03	No. 14
0.0915	2.32	No. 13
0.1055	2.68	No. 12
0.1205	3.06	No. 11
0.1350	3.43	No. 10
0.1483	3.77	No. 9
0.1620	4.11	No. 8

<sup>A</sup>Allowable variations in diameter shall be in accordance with tolerances as established in A 641/A 641M.

6.2 *Gypsum Lath*— Specification C 37.

6.3 *Expanded Metal Lath*— Specification C 847.

6.4 *Wire Lath*:

6.4.1 *Welded Wire Lath*, Specification C 933.

6.4.2 *Woven Wire Lath*, Specification C 1032.

6.5 *Fasteners*:

6.5.1 *Nails for Attaching Gypsum Lath*— Specification C 514. Nail size shall be in accordance with Table 1.

6.5.2 *Nails for Attaching Metal Plaster Base*—Galvanized roofing nails or common nails. length shall be as specified in 7.

6.5.3 *Screws*—Specifications C 954 or C 1002.

6.5.3.1 Screws for attaching gypsum lath shall be sized in accordance with Table 1.

6.5.3.2 Screws for attaching metal plaster base shall have a 7/16 in. (11.1 mm) diameter pan washer head and a 0.120 in. (3.0 mm) diameter shank. The length shall be sufficient enough to allow for the threaded portion of the screw to project not less than 3/8 in. (9.5 mm) through steel framing when the lath is installed.

**TABLE 1 Screws, Nails and Staples<sup>A,B</sup> for Attaching Gypsum Lath to Horizontal and Vertical Wood Supports**

Maximum Spacing, in. (mm)					Minimum Gage Requirements, in. (mm)			
Width of Lath	Thickness of Lath	Distance Between Supports	Number of Attachments per Bearing	Approximate Spacing <i>c</i> to <i>c</i> of Attachments	Length of Leg	Depth of Support Penetration	Diameter of Flat Head or Blued Nails or Crown Width of Staples <sup>A</sup>	Gage of Shank of Nails or Staples <sup>A</sup>
16 (406)	3/8 (9.5)	16 (406)	4	5 (127)	1 1/8 (28.6)	3/4 (19)	19/64 (7.5)	13
					1 (25.4) <sup>A</sup>	5/8 (15.9) <sup>A</sup>	7/16 (11) <sup>A</sup>	16 <sup>A</sup>
24 (610)	3/8 (9.5)	16 (406)	6	4 1/2 (114)	1 1/8 (28.6)	3/4 (19)	19/64 (7.5)	13
					1 (25.4) <sup>A</sup>	5/8 (15.9) <sup>A</sup>	7/16 (11) <sup>A</sup>	16 <sup>A</sup>
16 (406)	1/2 (12.7)	24 (610)	4	5 (127)	1 1/4 (32)	3/4 (19)	19/64 (7.5)	13
					1 1/8 (28.6) <sup>A</sup>	5/8 (15.9) <sup>A</sup>	7/16 (11) <sup>A</sup>	16 <sup>A</sup>
24 (610)	1/2 (12.7)	24 (610)	6	4 1/2 (114)	1 1/4 (32)	3/4 (19)	19/64 (7.5)	13 (330)
					1 1/8 (28.6) <sup>A</sup>	5/8 (15.9) <sup>A</sup>	7/16 (11) <sup>A</sup>	16 <sup>A</sup>
48 (1219)	3/8 (9.5)	16 (406)	8	4 1/2 (114)	1 1/8 (28.6)	3/4 (19)		
					1 (25.4) <sup>A</sup>	5/8 (15.9) <sup>A</sup>		
	1/2 (12.7)	24 (610)			1 1/4 (32)	3/4 (19)		
					1 1/8 (28.6) <sup>A</sup>	5/8 (15.9) <sup>A</sup>		

<sup>A</sup> Galvanized staples.

<sup>B</sup> Screws for attaching gypsum lath to wood supports shall be Type W as described in Specification C 1002.

**ASTM C 841**

6.5.4 *Staples*—Staples for attaching gypsum lath shall conform to the requirements of Table 1.

6.5.4.1 Staples for attaching metal plaster base shall be 0.062 in. (1.6 mm) diameter, round or flattened steel wire with 3/4 in. (19.0 mm) crown. Lengths shall be as specified for individual systems.

6.6 *Paper or Other Backing*—When used on metal plaster bases, over solid backing, backing shall be securely held in place by, or attached to the metal plaster base. Metal plaster base shall allow for 1/4 in. (6.4 mm) self furring. The backing shall permit embedment of plaster.

6.7 *Accessories*—Shall be steel, coated, with a protective rust inhibitive coating after fabrication, or fabricated from zinc-coated (galvanized) steel, aluminum, zinc alloy, or high impact plastic. Plastic accessories shall be manufactured in accordance with Specification D 1784 or Specification D 3678. Aluminum accessories shall be clear plastic coated. All accessories shall have perforated or expanded flanges or clips shaped so as to permit complete imbedment in the plaster, to provide means for secure alignment, and to secure attachment of the accessory to the underlying surface. Accessories shall be designed for the intended use and to receive or to permit application of the specified plaster thickness.

6.7.1 Thickness of base material for accessories shall be not less than as shown in the following:

Base Material (mm)	Thickness of Base Material, in.
Uncoated steel/zinc	0.014 (0.36)
PVC	0.030 (0.76)
Aluminum	0.050 (1.27)

6.7.2 *Control Joints*— Shall be formed by using a single prefabricated member or fabricated by installing casing beads back to back with a flexible barrier membrane behind casing beads. The separation spacing shall be not less than 1/8 in. (3.2 mm) or as required by the anticipated thermal exposure range.

6.7.3 *Cornerite*—shall be not less than 1.75 lb/yd<sup>2</sup> (0.85 kg/m<sup>2</sup>) expanded metal lath, galvanized, or given a protective coating of rust inhibitive paint after fabrication, or woven or welded fabric not less than 0.041 in. (1.04 mm) thick weighing not less than 1.75 lb/yd<sup>2</sup> (0.85 kg/m<sup>2</sup>), fabricated from galvanized wire. When shaped for angle reinforcing, cornerite shall have outstanding legs of not less than 2 in. (50.8 mm).

6.7.4 *Channels*—Shall be cold-rolled steel, free of rust with a coating of rust inhibitive paint or galvanized. Channels used in areas subject to corrosive action of salt air or other corrosive environments, shall be hot-dip galvanized. Weight of the channel shall be not less than as shown in the following:

Size	Weight		
	in.	mm	lb/1000 lf
3/4	19	300	0.446
1 1/2	38	475	0.707
2	50	590	0.818
2 1/2	64	665	0.989

6.7.5 Rod and flat (strap) hangers shall be mild steel, zinc coated or protected with a rust-inhibiting paint.

6.7.6 *Clips*—Devices for attaching framing members to supports or to each other; for attaching lath to framing members; or for securing lath to lath, shall be formed of

zinc-coated (galvanized) steel wire or sheet, and of sufficient size and strength to support the intended load

6.7.7 *Striplath*—Shall be not less than 1.75 lb/yd<sup>2</sup> (0.85 kg/m<sup>2</sup>) expanded metal lath, or woven or welded fabric of not less than 0.041 in. (1.04 mm) thick weighing not less than 1.75 lb/yd<sup>2</sup> (0.85 kg/m<sup>2</sup>) fabricated from galvanized steel.

**7. Installation**

7.1 *General Requirements for Application of Lath and Accessories:*

7.1.1 Lath shall be installed with the long dimension at right angles to supports, unless otherwise specified.

7.1.2 Corner beads shall be installed to protect all external corners and to establish grounds. Corner beads shall be attached to the substrate in such a manner as to ensure proper alignment during application of plaster.

7.1.3 Metal accessories shall be installed so that flanges and clips provided for their attachment are covered by the base coat plaster.

7.1.4 *Control Joints*—Shall be installed in ceilings greater than 2500 ft<sup>2</sup>(232 m<sup>2</sup>) in area and in partition, wall, and wall furring runs greater than 30 ft (9 m) in length. The distance between ceiling control joints shall not be more than 50 ft (15 m) in either direction. A control joint shall be installed where the ceiling framing or furring changes direction. The distance between control joints in walls or wall furring shall be not more than 30 ft (9 m). A control joint shall be installed where an expansion joint occurs in the base exterior wall or ceiling. A ceiling height door frame, installed in accordance with the spacing requirements set forth in this section, is not prohibited from being used as a control joint.

7.1.5 Where partition assemblies require the installation of control joints over the head of door frames to relieve stresses within the assemblies, such control joints shall be installed in the following manner:

7.1.5.1 Where control joints are located at the vertical center of the door opening two metal studs shall be installed not more than 1/2 in. (12.7 mm) apart over the center of the span at the head of the frame, with the lath installed so that a vertical joint occurs between the studs. A prefabricated control joint or casing beads shall be installed at the joint location.

7.1.5.2 Where control joints are located in line with the door jambs the procedure in 7.1.5.1 shall be followed with the exception that supporting members shall consist of two studs placed side-by-side.

7.1.6 Casing beads or other suitable accessories, shall be used to isolate non-load bearing partitions from load bearing members.

7.1.7 *Workmanship*—Metal construction furring and lathing shall be erected so that finished plaster surfaces will be true to line, level, plumb, square, curved, or as required to receive specified plaster thickness.

7.1.8 Except where frames are required to be fully grouted with plaster, lath shall be inserted into jambs as far as possible and notched to pass anchors.

7.2 *Application of Gypsum Lath to Supports:*

7.2.1 *General*—Gypsum lath shall be installed so that vertical joints occur not less than one full stud space from edges of openings in walls or partitions.

**ASTM C 841**

7.2.2 Gypsum lath shall be installed with the face side out and the edges and ends butted together. End joints shall fall on different supports in alternate courses, or the lath shall be installed so that end joints are continuous on one support. In the latter case, the continuous end joints shall be covered with 3-in. (76-mm) wide strips of metal lath or welded or woven wire fabric, and the long edge joints of lath in alternate courses shall be offset or staggered.

7.2.3 Cornerite shall be installed on gypsum lath at all internal angles, and lightly nailed or stapled to the gypsum lath and not to the framing members. Cornerite shall not be used in unrestrained construction, or where other provisions are made for the treatment of internal angles.

7.2.4 Where gypsum lath sheets intersect or where joint surfaces are to be plastered without lathing (such as masonry), a casing bead shall be installed at the intersection or joining.

7.2.5 Gypsum lath shall be reinforced at the corners of doors, windows, or other openings with diagonally installed strips of striplath or wire lath, not less than 6 in. (152 mm) wide by 12 in. (305 mm) long.

7.2.6 Metal lath stripping shall be used to cover chases and similar breaks in continuity or horizontal or vertical surfaces that are to receive plaster. Stripping shall be extended not less than 3 in. (76 mm) on all sides of the openings.

**7.3 Application of Gypsum Lath to Wood Supports:**

7.3.1 Except where required otherwise, for certain fire-resistant construction, gypsum lath shall be securely attached to wood supports using nails, screws, or staples conforming to Table 1.

7.3.2 Nails and screws shall be driven so that the face of the head is flush with the face of the gypsum lath, and not less than 3/8 in. (9.5 mm) from the edges of the lath. Staples shall be driven with the crown parallel to the nailing members. The crown shall bear lightly against, but not cut into, the face of the lath.

**7.4 Application of Gypsum Lath to Metal Supports:**

7.4.1 Gypsum lath shall be attached to horizontal or vertical

metal supports with staples, screws, or nails, or a combination thereof.

7.4.2 Screws shall be driven so that the face of the head is flush with the face of the gypsum lath and not less than 3/8 in. (9.5 mm) from the edges of the lath.

**7.5 Studless Solid Partitions (Gypsum Lath and Plaster):**

7.5.1 Gypsum lath shall be plain, 1/2 in. (12.7 mm) thick, 24 in. (610 mm) wide, and, when applied vertically, shall be not more than 12 ft (3.7 m) in length.

7.5.2 Wood floor runners shall be secured to the floor using anchors spaced not more than 24 in. (610 mm) on center. Anchors shall penetrate floor surface to a depth of not less than 5/8 in. (15.9 mm). The width of such runners shall correspond to the overall partition thickness and their upper surface shall be grooved parallel to the length of the runner in the center to a depth of not less than 1/2 in. (12.7 mm) and to a width to accommodate snugly the thickness of the lath.

7.5.3 Metal floor runners shall be anchored to bases and clips at not more than 24 in. (610 mm) on center. Runners shall be designed to hold the lower edge of the lath securely in position.

7.5.4 Metal ceiling runners shall be aligned with floor runners to ensure plumb installation of the lath. Metal ceiling runners shall be firmly secured to the ceiling construction.

7.5.5 Gypsum lath shall be of such length as to allow not less than 1/4 in. (6.4 mm) nor more than 1-in. (25.4-mm) top clearance in the ceiling runner. Erect gypsum lath vertically so as to engage the ends in or to the floor and ceiling runners.

7.5.6 the vertical edges of the lath shall be aligned with the vertical joints interlocked or mechanically fastened with type G screws spaced not more than 12 in. (305 mm) on centers.

**7.6 Application of Metal Plaster Bases to Framing Members:**

7.6.1 *General*—The spacing of supports for the type and weight of metal lath used shall be in accordance with the requirements of Table 2.

**7.6.2 Attachments for Metal Plaster Bases to Wood Framing Members:**

**TABLE 2 Types and Weights of Expanded Metal Lath, Sheet Lath, or Welded Wire Lath and Corresponding Maximum Permissible Spacing of Supports<sup>A</sup>**

Type of Metal Plastering Base	Minimum Weight of Metal Base, lb/yd <sup>2</sup> (kg/m <sup>2</sup> )	Maximum Permissible Spacing of Supports Center for Center, in. (mm)				
		Walls (Partitions)			Ceilings	
		Wood Studs	Solid Partitions	Steel Studs, Wall Furring, etc.	Wood or Concrete	Metal
Expanded metal lath:						
Diamond mesh	2.5 (0.08)	16 (406)	16 (406)	16 (406)	12 (305)	12 (305)
	3.4 (0.12)	16 (406)	16 (406)	16 (406)	10 (254)	16 (406)
Flat rib	2.5 (0.08)	16 (406)	12 (305)	12 (305)	12 (305)	12 (305)
	2.75 (0.09)	16 (406)	16 (406)	16 (406)	16 (406)	16 (406)
	3.4 (0.12)	19 (483)	24 (610)	19 (483)	19 (483)	19 (483)
Flat rib (large opening)	1.8 (0.06)	24 (610)	24 (610)	24 (610)	16 (406)	16 (406)
3/8-in. (9.5-mm) rib						
	3.4 (0.12)	24 (610)	N/A	19 (482)	19 (482)	19 (482)
	4.0 (0.14)	24 (610)	N/A	24 (610)	24 (610)	24 (610)
Wire lath welded	1.4 (0.05) <sup>B</sup>	16 (406)	16 (406)	16 (406)	16 (406)	16 (406)
	1.95 (0.07) <sup>C</sup>	24 (610)	24 (610)	24 (610)	24 (610)	24 (610)

<sup>A</sup> Paper-backed lath shall be limited to lath having an absorbent and a perforated slotted paper separator only.

<sup>B</sup> Welded wire paper-backed lath, 16-gage, 0.0598 in., (1.52 mm).

<sup>C</sup> Welded wire, paper-backed lath, 16-gage face wire, 0.0598 in. (1.52 mm) face wire.

 **C 841**

7.6.2.1 Diamond mesh expanded metal lath, flat rib expanded metal lath, and welded wire lath shall be attached to horizontal wood supports with 1½ in. (38 mm), 0.1205 in. (3.06 mm) shank, 7/16 in. (11 mm) diameter head, barbed, galvanized, or blued roofing nails driven flush with the lath. The metal lath shall be attached to vertical wood supports with 6d common nails, or 1-in. (25-mm) long roofing nails driven in accordance with Table 1 or 1-in. No. 14 gage wire staples driven flush with the lath.

7.6.2.2 3/8-in. (9.5-mm) rib expanded metal lath shall be attached to horizontal and vertical wood supports with nails or staples not less than 3/8 in. (9.5 mm) longer than required (7.6.2.1) to provide not less than 3/8-in. (9.5-mm) longer than required (see 7.6.2.1) to provide penetration in accordance with Table 1.

7.6.2.3 When used on vertical wood supports, common nails shall be bent over to engage not less than three strands of lath. When used for the application of rib lath, common nails shall be bent over to engage not less than one rib of the lath.

7.6.2.4 Other methods of attachment shall be used when it can be shown they provide a carrying strength not less than that described in 7.6.2.1-7.6.2.3 may be used.

7.6.3 *Attachments for Metal Plaster Bases to Metal Framing Members:*

7.6.3.1 Metal plaster bases shall be attached to metal framing members with 0.048 in. (1.2 mm) diameter wire ties, clips, or modified truss (wafer-headed) screws installed so that the threaded portion of the screw will penetrate the metal supports not less than 3/8 in. (9.5 mm) and the head shall contact not less than three strands of lath.

7.6.3.2 Rib metal lath shall be attached to open web steel joists using single ties of galvanized, annealed steel wire, 0.048 in. (1.2 mm) in diameter, with the ends of each tie wire twisted together 1½ times.

7.6.3.3 Rib metal lath shall be installed to metal framing members with the point of the V rib in contact with the framing and attached to the framing by a screw driven through the rib so that the threaded portion of the screw penetrates the metal support not less than 3/8 in. (9.5 mm).

7.6.4 *Attachments for Metal Plaster Bases to Concrete Supports*—Rib metal lath shall be attached to concrete joists by loops of galvanized, annealed steel wire, not less than 0.076 in. (1.9 mm) in diameter, with the ends of each loop twisted together not less than 1½ times.

7.6.5 *Spacing of Attachments for Metal Plaster Bases*—Attachments for securing metal plaster bases to supports shall be spaced not more than 7 in. (178 mm) apart for diamond mesh and flat rib laths and at each rib for 3/8-in. (9.5-mm) rib lath.

7.6.6 *Lapping of Metal Plaster Bases:*

7.6.6.1 Side laps of metal plaster bases shall be secured to supports, and tied between supports at intervals not more than 9 in. (229 mm) on center.

7.6.6.2 Expanded metal lath shall be lapped ½ in. (12.7 mm) at edges, or the edge ribs shall be nested. Welded or woven wire lath shall be lapped one mesh at sides and ends. Expanded metal lath shall be lapped 1 in. (25 mm) at ends or ends shall be nested. When end laps occur between supports,

the ends of sheets of all metal plaster bases shall be tied together with 0.048 in. (1.2 mm), galvanized, annealed steel wire. Laps shall be located not more than 3 in. (76.2 mm) from the structural support. Lath shall be lapped not more than 3 in. (76.2 mm) in any direction.

7.6.6.3 Adjacent sheets of metal plaster base shall be installed so that metal laps onto metal and backing laps onto backing.

7.6.7 *Procedure for Application of Metal Plaster Bases to Ceiling Framing Members:*

7.6.7.1 Metal plaster bases shall be applied to ceilings first.

7.6.7.2 The ends of metal plaster bases shall be staggered.

7.6.7.3 Where furred or suspended ceilings greater than 50 ft (15 m) in either direction or 2500 ft<sup>2</sup> (232 m<sup>2</sup>) in area butt into or are penetrated by columns, walls, beams, or other elements, the following procedure shall be used: The sides and ends of the ceiling lath shall abut at the horizontal internal angles and terminate at a casing bead, control joint, or similar device designed to isolate the plaster membrane from the adjoining vertically oriented elements. Only casing beads shall be used at internal angles between ceilings, walls, or partitions. Lath shall not be continuous through control joints but shall be stopped and tied to the flanges of the control joint at each side.

7.6.8 Ends of sheets of diamond mesh metal lath and welded wire lath on partitions not abutting structural walls, columns, or floor-ceiling slabs shall be bent into or around vertical corners and continued on to not less than one support away from the corner. The ends of the sheets of lath shall be butted into corners when cornerite is applied over the abutting laths. Rib metal lath shall be butted into corners and cornerite shall be applied over the abutting laths.

7.6.9 The ends of metal plaster bases applied to load-bearing wall and partitions that abutt structural walls, columns, or floor-ceiling slabs shall be isolated from the adjacent surface at the internal angle. Cornerite shall not be used at internal angles, only casing beads or control joint materials shall be used to isolate the lath and plaster from the abutting surface.

7.7 *Studless Solid Partitions (Metal Lath and Plaster):*

7.7.1 Metal plaster bases used for studless solid partitions shall have the sides (long dimensions) of the sheet installed vertically. The plaster bases shall be wiretied to the ceiling runners using ties spaced not more than 8 in. (203 mm) on center and mechanically anchored to the floor runners or base.

7.7.1.1 At vertical internal and external corners, metal plaster bases shall be bent and returned 6 in. (152 mm) on abutting surfaces. Rib metal lath shall be lapped ½ in. (12.7 mm) at sides, or the outside ribs shall be nested. Side laps shall be wire tied between supports at intervals not more than 9 in. (229 mm) on center.

7.8 *Suspended and Furred Ceilings (Metal Lath and Gypsum Lath Construction):*

7.8.1 Hangers shall be of sufficient length to accommodate the ceiling construction.

7.8.1.1 Hangers (without inserts) shall be secured or otherwise embedded so as to develop full strength.

7.8.1.2 *Inserts*—Inserts for hangers shall be secured in concrete reinforced slabs so as to develop the full strength of the hangers that are attached to them.

**ASTM C 841**

7.8.2 Hangers for Suspended Ceilings Under Wood Constructions—Hangers shall conform with the requirements of Table 3 both as to size and maximum area to be supported, except as modified in this section. Hangers shall be attached to supports by one of the following methods:

7.8.2.1 Insert through holes drilled not less than 3 in. (76 mm) above the bottom of the joist with the upper end of the hanger twisted not less than three times around itself (see Fig. 1).

7.8.2.2 Twisted not less than three times around itself over not less than three 12d nails driven on a downward slant into the sides of joists not less than 5 in. (127 mm) from the bottom edge of the joist and not more than 36 in. (914 mm) on center (see Fig. 2).

7.8.2.3 Formed into a loop to accommodate four 1 1/2-in. (38.1-mm), 0.148-in. (3.8-mm) diameter staples driven horizontally or on a downward slant into sides of joists, placing three near the upper end of the loop and the fourth to fasten the loose end (see Fig. 3).

7.8.2.4 Where spacing of supports is more than 4 ft (1.2 m) on center, 1 1/2-in. (38.1-mm) No. 0 screw eyes, or equivalent, spaced not more than 3 ft (0.9 m) on centers shall be screwed into supporting wood construction so that the supported area shall be not more than 9 ft<sup>2</sup> (0.8 m<sup>2</sup>). The upper end of the wire hanger shall be inserted through the screw eye and in each case twisted not less than three times around itself.

7.8.2.5 Flat hangers shall be secured with two 12d nails driven through holes drilled in the hanger and clinched not less

**TABLE 3 Suspended and Furred Ceilings, Minimum Sizes for Wire, Rod, and Rigid Hangers; Minimum Sizes and Maximum Spans and Spacings for Main Runners; and Minimum Sizes and Maximum Spans and Spacings for Cross Furring**

NOTE 1— 1 in. = 25.4 mm; 1 ft<sup>2</sup> = 0.093 m<sup>2</sup>

HANGERS		
	Maximum Ceiling Area Supported, ft <sup>2</sup>	Minimum Size of Hangers
Hangers for Suspended Ceilings	12.5	0.148 in. wire
	16	0.162 in. wire
	18	3/16-in. diameter, mild steel rod <sup>A</sup>
	20	7/32-in. diameter, mild steel rod <sup>A</sup>
	22.5	1/4-in. diameter, mild steel rod <sup>A</sup>
Attachments for Tying Runners and Furring Directly to Beams and Joists For Supporting Runners Single Hangers Between Beams <sup>C</sup>	25.0	1 by 3/16-in. mild steel strap <sup>B</sup>
	8	0.106 in. wire
	12	0.135 wire
	16	0.162 wire
	8	0.076 wire
Double Wire Loops at Beams or Joists <sup>C</sup>	12	0.106 wire
	16	0.120 wire
	8	0.076 wire
For Supporting Furring Without Runners <sup>C</sup> (Wire Loops at Supports) Types of Support:	8	0.076 wire
	8	0.062 (2 loops) <sup>D</sup>
	8	0.062 (2 loops) <sup>D</sup>
	8	0.062 (2 loops) <sup>D</sup>
SPANS AND SPACINGS OF MAIN RUNNERS <sup>E,F</sup>		
Minimum Size and Type	Maximum Span Between Hangers or Supports, in.	Maximum Center to Center Spacing of Runners, in.
3/4 in., 0.3 lb/ft, cold	24	36
1 1/2 in. 0.475 lb/ft, cold-rolled channel	36	48
1 1/2 in., 0.475 lb/ft, cold-rolled channel	42	42
1 1/2 in., 0.475 lb/ft, cold-rolled channel	48	36
2 in., 0.59 lb/ft, cold-rolled channel	60	48
1 1/2 by 1 1/2 by 3/16-in. angle	60	42
SPANS AND SPACINGS OF CROSS FURRING <sup>E,F</sup>		
Minimum Size and Type	Maximum Span Between Runners or Supports, in.	Maximum Center to Center Spacing of Cross Furring Members, in.
1/4-in. diameter pencil rods	24	12
3/8-in. diameter pencil rods	24	19
3/8-in. diameter pencil rods	30	12
3/4 in., 0.3 lb/ft, cold	36	24
	42	19
	48	16

<sup>A</sup> All rod hangers shall be protected with a zinc cadmium coating.

<sup>B</sup> All flat hangers shall be protected with a zinc or cadmium coating or with a rust-inhibitive paint.

<sup>C</sup> Inserts, special clips, or other devices of equal strength are substitutes for those specified.

<sup>D</sup> Two loops of 0.048 in. wire are substitutes for each loop of 0.062 in. wire when used for attaching steel furring to steel or wood joists.

<sup>E</sup> Spans are based on webs of channels being erected and maintained in a vertical position.

<sup>F</sup> Other sections of cold-rolled members of equivalent beam strength are substitutes for those specified.

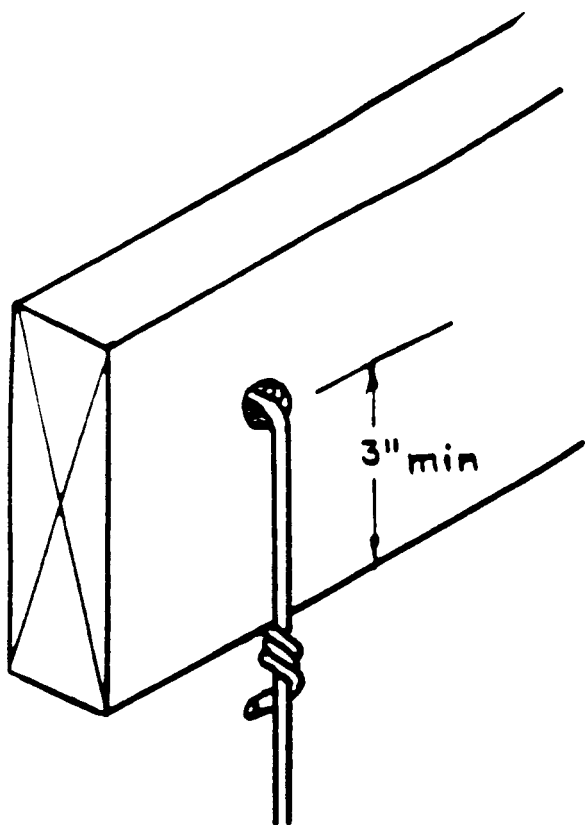

FIG. 1 Hanger Attached to Support Through a Drilled Hole

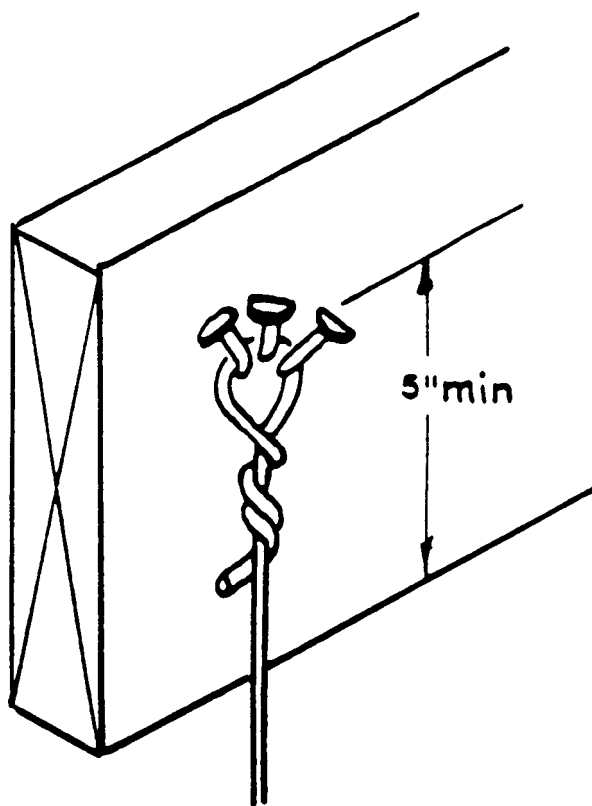

FIG. 2 Hanger Attached to Support Using Nails

than 3 in. (76 mm) above the bottom of the joists (see Fig. 4).

7.8.3 *Minimum Size for Hangers*—Thickness of wire hangers, diameter of rod hangers, and sizes of flat hangers shall be in accordance with Table 3.

7.8.4 Where 1 by  $\frac{3}{16}$ -in. (25.4 by 4.8-mm) flat inserts and hangers are used,  $\frac{7}{16}$ -in. (11-mm) diameter holes shall be punched on the center line at the lower end of inserts and upper end of hanger to permit the attachment of the hangers to the insert.

7.8.5 Holes in both inserts and hangers shall be not less than  $\frac{3}{8}$  in. (9.5 mm) from the ends.

7.8.6 Flat steel hangers shall be bolted to 1 by  $\frac{3}{16}$ -in. (25.4 by 4.8-mm) inserts with  $\frac{3}{8}$ -in. (9.5-mm) diameter round-head stove bolts.

7.8.7 The nuts of bolts shall be drawn up tight.

7.8.8 Wire or rod hangers shall be saddle-tied or attached to main runners so as to prevent turning or twisting of the runners and to develop the full strength of the hangers and the runners. Smooth or threaded rod hangers shall be attached to inserts and runners with special attachments designed for this application.

7.8.9 The lower ends of flat hangers shall be bolted to the main runners, or bent tightly around runners and carried up and above the runners and bolted to the main part of the hanger. Bolts shall be  $\frac{3}{8}$ -in. (9.5-mm) diameter, stove bolts.

#### 7.9 *Main Runners:*

7.9.1 Minimum sizes and maximum spans and spacings of main runners for the various spans between hangers or other supports shall be in accordance with Table 3.

7.9.2 A clearance of not less than 1 in. (25.4 mm) shall be provided between the ends of main runners and abutting

masonry or reinforced concrete walls, partitions and columns. Where special conditions require main runners to penetrate the plane of abutting masonry or concrete construction, a clearance shall be provided within such constructions of not less than 1 in. (25 mm) from the ends and not less than  $\frac{1}{2}$  in. (12.7 mm) from the tops and sides of the runners.

7.9.3 A main runner shall be located not more than 6 in. (152 mm) from the paralleling wall to support the ends of the cross furring. The ends of main runners shall be supported by hangers located not more than 6 in. (152 mm) from the ends.

7.9.4 When main runners are spliced, the ends shall be overlapped not less than 12 in. (305 mm), with flanges of channels interlocked, and securely tied near each end of the splice with double loops of 0.062 in. (1.6 mm) galvanized wire or double loops of twin strands of 0.048 in. (1.2 mm) galvanized wire.

#### 7.10 *Cross Furring:*

7.10.1 Minimum size and maximum spans and spacings of various types of cross furring for various spans between main runners and supports shall be in accordance with Table 3.

7.10.2 Cross furring shall be securely saddle-tied to main runners with 0.062 in. (1.6 mm) galvanized wire, or a double strand of 0.048 in. (1.2 mm) galvanized wire or with special galvanized clips, or equivalent attachments.

7.10.3 When cross furring members are spliced, the ends shall be overlapped not less than 8 in. (203 mm), with flanges of channels interlocked, and securely tied near each end of the splice with double loops of either 0.062 in. (1.6 mm) galvanized wire or twin strands of 0.048 in. (1.2 mm) galvanized wire.

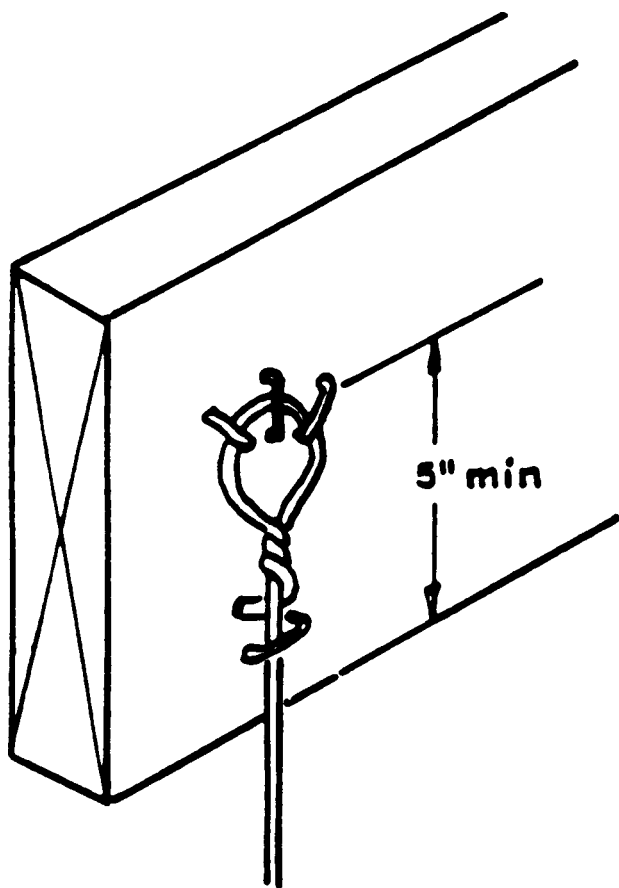

FIG. 3 Hanger Attached to Support Using Staples

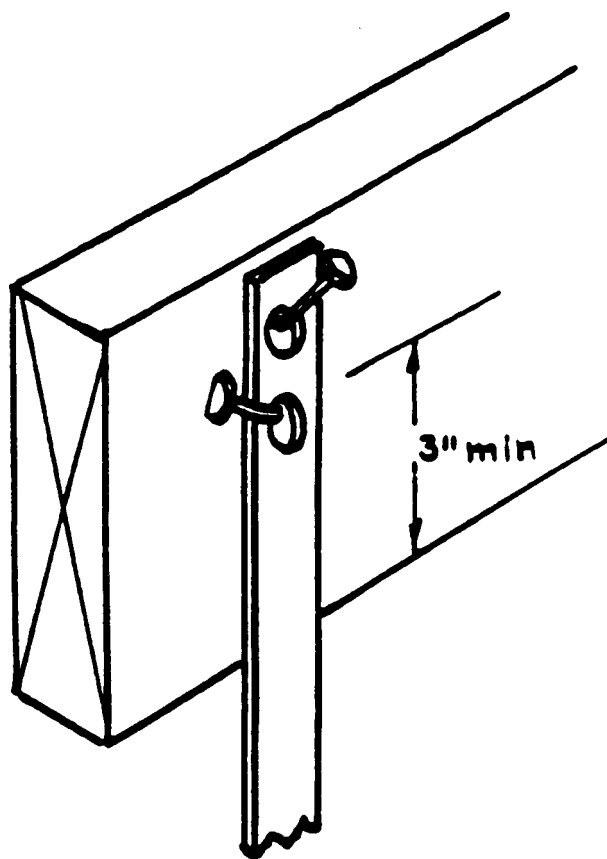

FIG. 4 Flat Hanger Attached to Support Using Nails

7.10.4 Cross furring shall not contact abutting masonry or reinforced concrete walls or partitions.

7.10.4.1 Where special conditions require cross furring to penetrate the plane of the abutting masonry or concrete construction, the applicable provisions of 7.9.2 shall apply.

7.10.5 Main runners and cross furring shall be interrupted at control and expansion joints. The resulting intersections shall be constructed by splices, snugly tied, but loose enough to allow for lateral movement (telescoping) of the framing members and expansion and contraction of the plaster membrane.

#### 7.11 Metal Furring for Walls:

7.11.1 Attachments for furring shall consist of nails driven securely into concrete or into masonry joints, short pieces of  $\frac{3}{4}$  in. (19 mm) channels used as anchors driven into masonry joints, or other devices specifically designed as spacer elements. Furring shall be spaced horizontally not more than 2 ft (610 mm) on centers. Furring shall be spaced vertically in accordance with horizontal stiffener spacing so that it projects from the face of the wall enough to permit ties to be made.

7.11.2 Where dampproofing has been damaged in installa-

tion of attachments, the dampproofing shall be repaired with the same material before proceeding with the installation of the furring.

7.11.3 Horizontal stiffeners shall be not less than  $\frac{3}{4}$ -in. (19-mm) hot-rolled or cold-rolled channels, spaced not to exceed 60 in. (1524 mm) on center vertically, with the lower and upper channels not more than 6 in. (152 mm) from the floor and ceiling, and not less than  $\frac{1}{4}$  in. (6.4 mm) from the face of the wall. Stiffeners shall be securely tied to attachments with three loops of 0.048 (1.2 mm) wire.

7.11.4 Vertical members shall be not less than  $\frac{3}{4}$ -in. (19-mm) cold-rolled channels, in accordance with requirements in Table 2. Members shall be saddle-tied to horizontal members with three loops of 0.048 in. (1.2 mm) galvanized soft-annealed wire, or equivalent devices, at each crossing, and securely anchored to the floor and ceiling constructions. If furring is not in contact with the wall, then channel braces shall be installed between horizontal stiffeners and the wall, spaced not more than 2 ft (600 mm) apart (horizontal spacing).

## 8. Keywords

8.1 furring; gypsum; lathing; plaster





## ANNEXES

### (Mandatory Information)

#### A1. GENERAL INFORMATION

The work shall include all labor, materials, services, equipment, and scaffolding required to complete the lathing and furring of the project in accordance with the drawings and specifications.

A1.1 *Floating Angle Construction*—Except where required otherwise for certain fire-resistive construction, nails or staples occurring less than 6 in. (152 mm) from internal angles shall not be prohibited from being omitted in the application of gypsum lath, provided each piece of lath is nailed to not less than two supports. Where lath abuts masonry, the angle shall not be “floated” and a plaster stop or casing bead shall be used.

A1.1.1 Gypsum lath, for floating angle construction, shall be applied to ceiling areas first, so that the ceiling lath will be supported in the angles by the upper edge of the top course of lath applied to walls or partitions.

A1.2 *Wood Furring*—For the attachment of wall finishes, wood furring shall be not less than  $\frac{3}{4}$  in. (19 mm) by  $1\frac{1}{2}$  in. (38.1 mm) (actual size) where applied to solid backing such as masonry. Wood furring attached to supports, spaced not more than 24 in. (610 mm) on centers, shall be not less than  $1\frac{1}{2}$  by  $1\frac{1}{2}$  in.

#### A2. TECHNICAL INFORMATION

##### A2.1 *Solid Plaster Partitions with Steel Studs:*

A2.1.1 Steel studs for solid plaster partitions shall be installed in accordance with Specifications C 754 and C 1007 and shall be of a size and number and located to provide backing at all corners. Steel studs shall be set to the required spacing, properly aligned, made plumb and true, securely anchored to the floor and ceiling construction, and temporarily braced, if necessary.

A2.1.2 Where studs do not fall at edges of openings, extra studs shall be added. Such studs shall be securely anchored to the door frames.

A2.1.3 Space above headers of openings extending to the ceiling shall be reinforced by installing studs 16 in. (406 mm) on center over the heads of the openings.

A2.2 *Hollow Metal Door Frames* for prefabricated steel stud, channel stud, lath and plaster hollow partitions.

A2.2.1 Door frames shall be installed in accordance with NAAMM Standard HMMA 840 .

#### A3. DESIGN AND ERECTION OF HOLLOW DOOR METAL FRAMES FOR PREFABRICATED STEEL STUD AND CHANNEL STUD, LATH AND PLASTER HOLLOW PARTITIONS

A3.1 *Hollow Metal Frames* (for Prefabricated Steel Stud, Channel Stud, Lath and Plaster Hollow Partitions):

A3.1.1 Metal studs shall be installed at each jamb of the steel frame by wiretying, bolting, or welding them to jamb anchors in the frame. The edges of the studs shall be inserted into the notches or other devices provided in the jamb anchor insert clips.

A3.1.2 The first stud on either side of the frame shall be fastened to suitable anchorage at the top and bottom of the partition in accordance with the instructions of the stud manufacturer. A second metal stud shall be placed not more than 2 in. (50 mm) away from the first stud, using adequate means of attachments between the two; or, two metal studs shall be attached to jamb anchors and securely fastened back to back.

A3.1.3 Where metal door frames have an adjustable strut equal in stiffness to a stud, running from each jamb to the ceiling, one metal stud shall be installed at each jamb in the

manner previously noted.

A3.1.4 At the head of the metal frame, a section of metal floor track shall be placed horizontally within the head section, and fastened to the jamb studs with wire ties, screws, or welds. Frames over 32 in. (813 mm) wide shall be provided with anchor insert clips spaced not over 24 in. (610 mm) on centers.

A3.1.5 Metal jack studs shall be installed over the head of the frame, spaced 16 in. (406 mm) on centers maximum, and shall be attached to the metal floor track. They shall be reinforced with a  $\frac{3}{4}$ -in. (19-mm) cold-rolled channel stiffener placed inside the partition and not more than 6 in. (152 mm) above the frame. Floor track is not required if one  $\frac{3}{4}$ -in. cold-rolled channel stiffener is placed horizontally on each interior face of the studs and not more than 6 in. above the frame. Channel stiffeners shall extend not less than two full stud spaces beyond the opening and shall be saddle-tied to each stud they cross.



## APPENDIXES

### X1. VENTILATION INFORMATION

X1.1 Adequate ventilation of attics or similar unheated spaces above gypsum plaster systems is essential to the performance of these systems and shall be designed and

provided by others per ASHRE Fundamentals Handbook or applicable buildings code.

### X2. GENERAL INFORMATION

X2.1 The work shall include all labor, materials, services, equipment, and scaffolding required to complete the lathing and furring of the project in accordance with the drawings and specifications.

X2.3 The work shall be coordinated with the work of other trades.

X2.2 Scaffolding shall be constructed and maintained in strict conformity with applicable laws and ordinances.

X2.4 Surfaces and openings shall be examined before furring or lathing is applied thereto, the proper authorities shall be notified, and unsatisfactory conditions shall be corrected prior to application of furring or lathing.

## SUMMARY OF CHANGES

This section identifies the location of changes to this specification that have been incorporated since the last issue. Committee C-11 has highlighted those changes that affect the technical interpretation or use of this specification.

(I) X1.1, X1.2, X1.2.1, X1.2.2, and X1.3 were replaced with a new X1.1.

*The American Society for Testing and Materials takes no position respecting the validity of any patent rights asserted in connection with any item mentioned in this standard. Users of this standard are expressly advised that determination of the validity of any such patent rights, and the risk of infringement of such rights, are entirely their own responsibility.*

*This standard is subject to revision at any time by the responsible technical committee and must be reviewed every five years and if not revised, either reapproved or withdrawn. Your comments are invited either for revision of this standard or for additional standards and should be addressed to ASTM Headquarters. Your comments will receive careful consideration at a meeting of the responsible technical committee, which you may attend. If you feel that your comments have not received a fair hearing you should make your views known to the ASTM Committee on Standards, at the address shown below.*

*This standard is copyrighted by ASTM, 100 Barr Harbor Drive, PO Box C700, West Conshohocken, PA 19428-2959, United States. Individual reprints (single or multiple copies) of this standard may be obtained by contacting ASTM at the above address or at 610-832-9585 (phone), 610-832-9555 (fax), or service@astm.org (e-mail); or through the ASTM website (www.astm.org).*