



Standard Specification for Masonry Cement¹

This standard is issued under the fixed designation C 91; the number immediately following the designation indicates the year of original adoption or, in the case of revision, the year of last revision. A number in parentheses indicates the year of last reapproval. A superscript epsilon (ε) indicates an editorial change since the last revision or reapproval.

This standard has been approved for use by agencies of the Department of Defense.

1. Scope

1.1 This specification covers three types of masonry cement for use where mortar for masonry is required.

1.2 The values stated in SI units are to be regarded as the standard. Values in SI units shall be obtained by measurement in SI units or by appropriate conversion of measurements made in other units, using the Rules for Conversion and Rounding given in IEEE/ASTM SI 10.

1.3 The text of this standard refers to notes and footnotes which provide explanatory material. These notes and footnotes (excluding those in tables and figures) shall not be considered as requirements of the standard.

1.4 The following safety hazards caveat pertains only to Sections 17 and 18 of this specification. *This standard does not purport to address all of the safety concerns, if any, associated with its use. It is the responsibility of the user of this standard to establish appropriate safety and health practices and determine the applicability of regulatory limitations prior to use.*

2. Referenced Documents

2.1 ASTM Standards:

- C 109/C 109M Test Method for Compressive Strength of Hydraulic Cement Mortars (Using 2-in. or 50-mm Cube Specimens)²
- C 151 Test Method for Autoclave Expansion of Portland Cement²
- C 183 Practice for Sampling and the Amount of Testing of Hydraulic Cement²
- C 185 Test Method for Air Content of Hydraulic Cement Mortar²
- C 187 Test Method for Normal Consistency of Hydraulic Cement²
- C 188 Test Method for Density of Hydraulic Cement²
- C 219 Terminology Relating to Hydraulic Cement²
- C 230 Specification for Flow Table for Use in Tests of Hydraulic Cement²
- C 266 Test Method for Time of Setting of Hydraulic Ce-

- ment Paste by Gillmore Needles²
- C 270 Specification for Mortar for Unit Masonry³
- C 305 Practice for Mechanical Mixing of Hydraulic Cement Pastes and Mortars of Plastic Consistency²
- C 430 Test Method for Fineness of Hydraulic Cement by the 45-μm (No. 325) Sieve²
- C 511 Specification for Moist Cabinets, Moist Rooms, and Water Storage Tanks Used in the Testing of Hydraulic Cements and Concretes²
- C 778 Specification for Standard Sand²
- IEEE/ASTM SI 10 Standard for Use of the International System of Units (SI): The Modern Metric System⁴

3. Terminology

3.1 Definitions:

3.1.1 *masonry cement*—a hydraulic cement, primarily used in masonry and plastering construction, consisting of a mixture of portland or blended hydraulic cement and plasticizing materials (such as limestone, hydrated or hydraulic lime) together with other materials introduced to enhance one or more properties such as setting time, workability, water retention, and durability.

3.1.2 Other terms used in this standard are defined in Terminology C 219.

4. Classification

4.1 *Type N*—For use in preparation of Specification C 270 Type N mortar without further addition of cements or hydrated lime, and for use in preparation of Specification C 270 Type S or Type M mortar when cement is added in accordance with the requirements of C 270.

4.2 *Type S*—For use in preparation of Specification C 270 Type S mortar without further addition of cements or hydrated lime.

4.3 *Type M*—For use in preparation of Specification C 270 Type M mortar without further addition of cements or hydrated lime.

5. Physical Properties

5.1 Masonry cement shall conform to the applicable requirements prescribed in Table 1 for its classification.

¹ This specification is under the jurisdiction of ASTM Committee C01 on Cement and is the direct responsibility of Subcommittee C01.11 on Masonry Cement.

Current edition approved Aug. 10, 2001. Published October 2001. Originally published as C 91 – 32 T. Last previous edition C 91 – 99.

² *Annual Book of ASTM Standards*, Vol 04.01.

³ *Annual Book of ASTM Standards*, Vol 04.05.

⁴ *Annual Book of ASTM Standards*, Vol 14.02.



TABLE 1 Physical Requirements

Masonry Cement Type	N	S	M
Fineness, residue on a 45- μ m (No. 325) sieve, max, %	24	24	24
Autoclave expansion, max, %	1.0	1.0	1.0
Time of setting, Gillmore method:			
Initial set, minutes, not less than	120	90	90
Final set, minutes, not more than	1440	1440	1440
Compressive strength (average of 3 cubes):			
The compressive strength of mortar cubes, composed of 1 part cement and 3 parts blended sand (half graded standard sand, and half standard 20–30 sand) by volume, prepared and tested in accordance with this specification shall be equal to or higher than the values specified for the ages indicated below:			
7 days, MPa (psi)	3.4 (500)	9.0 (1300)	12.4 (1800)
28 days, MPa (psi)	6.2 (900)	14.5 (2100)	20.0 (2900)
Air content of mortar, prepared and tested in accordance with requirements of this specification:			
Min, volume %	8	8	8
Max, volume %	21	19	19
Water retention value, min, % of original flow	70	70	70

6. Sampling

6.1 The masonry cement shall be sampled in accordance with Practice C 183.

7. Temperature and Humidity

7.1 The temperature and relative humidity of the air in the vicinity of the mixing slab and dry materials, molds, base plates, and mixing bowl shall conform to the requirements of Test Method C 109/C 109M.

7.2 The moist cabinet or moist room shall conform to the requirements of Specification C 511.

8. Fineness

8.1 Determine the residue on the 45- μ m (No. 325) sieve in accordance with Test Method C 430.

9. Normal Consistency

9.1 Determine normal consistency by the Vicat apparatus in accordance with Test Method C 187.

10. Autoclave Expansion

10.1 Determine autoclave expansion in accordance with Test Method C 151. After molding, store the bars in the moist cabinet or room for 48 h \pm 30 min before removal from the molds for measurement and testing in the autoclave. Calculate the difference in length of the test specimen before and after autoclaving to the nearest 0.01 % of the effective gauge length and report as the autoclave expansion of the masonry cement.

11. Time of Setting

11.1 Determine the time of setting by the Gillmore needle method in accordance with Test Method C 266.

12. Density

12.1 Determine the density of the masonry cement in accordance with Test Method C 188, using kerosine as the liquid. Use the density so determined in the calculation of the air content of the mortars.

13. Apparatus for Mortar Tests

13.1 *Weights and Weighing Devices, Seives, Glass Graduates, Specimen (Cube) Molds, Tamper, Trowel, and Testing*

Machine, as described in Test Method C 109/C 109 M.

13.2 *Flow Table*, conforming to the requirements prescribed in Specification C 230.

13.3 *Mixing Apparatus*, conforming to the requirements prescribed in Practice C 305.

13.4 *Measure, Straightedge, Tamper, Tapping Stick, and Spoon*, conforming to the requirements given in Test Method C 185.

13.5 *Specimen (Cube) Molds*—Molds shall be prepared in accordance with Test Method C 109/C 109 M.

14. Blended Sand

14.1 The sand shall be a blend of equal parts by weight of graded standard sand and standard 20–30 sand conforming to Specification C 778.

15. Preparation of Mortar

15.1 *Proportions for Mortar*—Mortar for air entrainment, compressive strength, and water retention tests shall be proportioned to contain 1620 g of sand and a mass of cement, in grams, in accordance with Table 2. The sand shall consist of 810 g of graded standard sand and 810 g of 20–30 standard sand (Note 1). The quantity of water, measured in millilitres shall be such as to produce a flow of 110 \pm 5 as determined by Test Method C 109/C 109M.

NOTE 1—Historically, field-mixed mortar has been proportioned by volume measured in increments or fractions of ft³. The comparable whole SI-unit volume to 1 ft³ is 28 L. The specified mortar proportions approximate the 1:3 nominal proportions by volume, commonly specified for construction, on the basis of the following assumed mass and volume relationships:

- The mass of dry sand in 28 L of loose damp sand is 36 kg.
- 28 L Type N masonry cement has a mass of 32 kg.
- 28 L Type S masonry cement has a mass of 34 kg.
- 28 L Type M masonry cement has a mass of 36 kg.

TABLE 2 Cement in Laboratory Batch of Mortar

Masonry Cement Type	Mass of Cement, g
N	480
S	510
M	540

 **C 91**

For example, the amount of cement needed to provide a 1:3 volume proportion of cement to sand using a Type N masonry cement is as follows:

$$A = 1620 \times (C/B) = 1620 \times (32/108) = 480 \quad (1)$$

where:

A = number of grams of cement to be used in the mortar with 1620 g of sand,

B = $3 \times 36 = 108$ kg, the mass of dry sand in 84 (or 3×28) L of loose damp sand, and

C = mass of Type N masonry cement per 28 L.

15.2 *Mixing of Mortars*—Mix the mortar in accordance with Practice C 305.

16. Air Entrainment

16.1 *Procedure*—If the mortar has the correct flow, use a separate portion of the mortar for the determination of entrained air. Determine the mass of 400 mL of mortar in accordance with Test Method C 185.

16.2 *Calculation*—Calculate the air content of the mortar and report it to the nearest 1 % as follows:

$$D = (W_1 + W_2 + V_w)[(W_1/S_1) + (W_2/S_2) + V_w] \quad (2)$$
$$A = 100 - (W_m/4D)$$

where:

D = density of air-free mortar, g/cm³,

W_1 = mass of cement, g,

W_2 = mass of sand, g,

V_w = millilitres-grams of water used,

S_1 = density of cement, g/cm³

S_2 = density of standard sand, 2.65 g/cm³,

A = volume percent of entrained air, and

W_m = mass of 400 mL of mortar, g.

17. Compressive Strength

17.1 Test Specimens:

17.1.1 *Molding*—Immediately after determining the flow and mass of 400 mL of mortar, return all of the mortar to the mixing bowl and remix for 15 s at the medium speed. Then mold the test specimens in accordance with Test Method C 109/C 109 M, except that the elapsed time for mixing mortar, determining flow, determining air entrainment, and starting the molding of cubes shall be within 8 min.

17.1.2 *Storage*—Immediately after molding, store all test specimens in the molds on plane plates in a moist cabinet or moist room for 48 to 52 h in such a manner that the upper surfaces shall be exposed to the moist air. Then remove the cubes from the molds, and place them in the moist cabinet or moist room for 5 days in such a manner as to allow free circulation of air around at least five faces of the specimens. At the age of 7 days, immerse the cubes for the 28-day tests in saturated lime water in storage tanks of noncorrodible materials.

17.2 Procedure:

17.2.1 Test the cube specimens immediately after their removal from the moist cabinet or moist room for 7-day specimens, and immediately after their removal from storage water for all other specimens. If more than one specimen at a time is removed from the moist cabinet or moist room for

7-day tests, cover these cubes with a damp cloth until the time of testing.

17.2.2 The remainder of the testing procedure shall conform to Test Method C 109/C 109 M.

18. Water Retention

18.1 Apparatus:

18.1.1 *Water-Retention Apparatus*—For the water-retention test, apparatus essentially the same as those shown in Fig. 1 or Fig. 2 shall be used. These apparatuses consist of a water aspirator or other source of vacuum controlled by a mercury relief column or a vacuum regulator with a capacity of not more than 400 mm of mercury and connected by way of a three-way stopcock to a funnel upon which rests a perforated dish. The perforated dish shall be made of metal not attacked by masonry mortar. The metal in the base of the dish shall have a thickness of 1.7 to 1.9 mm and shall conform to the requirements given in Fig. 1. The stopcock bore shall have a 4.0 ± 0.5 mm in diameter, and the connecting glass tubing shall have a minimum inside diameter of 4 mm. A mercury manometer, connected as shown in Fig. 1, or a vacuum gauge capable of reading to at least 70 mm of mercury in 1-mm increments as shown in Fig. 2, indicates the vacuum. The contact surfaces of the funnel and perforated dish shall be plane and are permitted to be lapped to ensure intimate contact. An air-tight seal shall be maintained between the funnel and the dish during a test. This shall be accomplished by either of the following procedures: (1) a synthetic (grease-resistant) rubber gasket shall be permanently sealed to the top of the funnel using petrolatum or light grease to ensure a seal between the gasket and dish, or (2) the top of the funnel shall be lightly coated with petrolatum or light grease to ensure a seal between the funnel and dish. Care shall be taken to ensure that none of the holes in the perforated dish are clogged. Hardened, very smooth, not rapid filter paper shall be used. It shall be 150 mm in diameter and be placed so as to completely cover the perforations in the dish.

18.1.2 *Straightedge*—A steel straightedge not less than 200 mm (8 in.) long and not less than 2 mm ($1/16$ in.) nor more than 3 mm ($1/8$ in.) in thickness.

18.1.3 *Other Apparatus*—Other apparatus required for the water retention test shall conform to the applicable requirements of Section 13.

18.2 Procedure:

18.2.1 Adjust the mercury relief column or vacuum regulator to maintain a vacuum of 51 ± 3 mm as indicated by the manometer or vacuum gauge. Seat the perforated dish on the greased gasket or greased rim of the funnel. Place a wetted filter paper in the bottom of the dish. Turn the stopcock to apply the vacuum to the funnel and check the apparatus for leaks and to determine that the required vacuum is obtained. Then turn the stopcock to shut off the vacuum from the funnel.

18.2.2 Mix the mortar to a flow of 110 ± 5 % in accordance with Practice C 305. Immediately after making the flow test, return the mortar on the flow table to the mixing bowl and remix the entire batch for 15 s at medium speed. Immediately after remixing the mortar, fill the perforated dish with the mortar to slightly above the rim. Tamp the mortar 15 times with the tamper. Apply ten of the tamping strokes at approximately

ASTM C 91

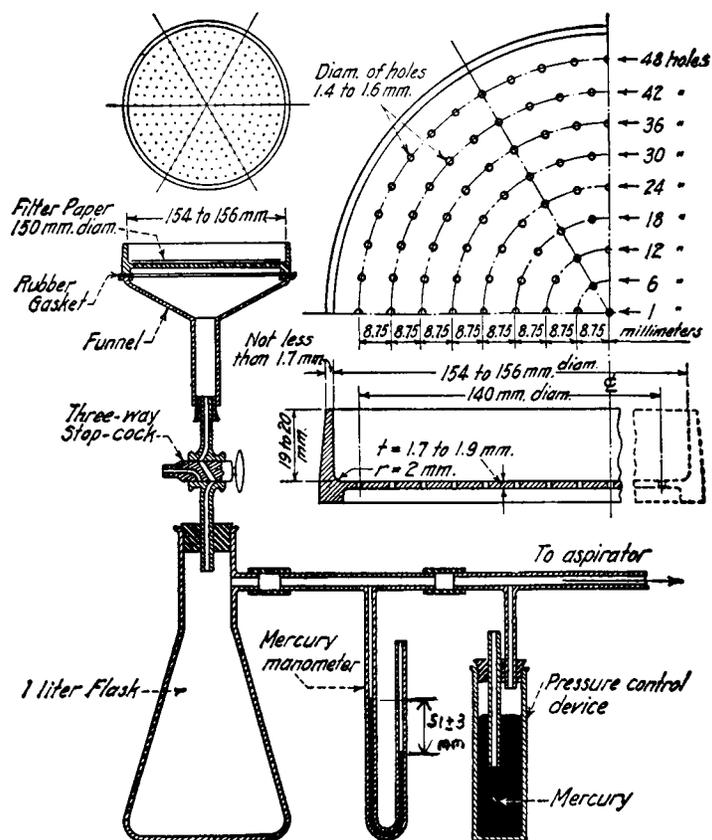

NOTE 1—The gasket is to be synthetic rubber. The stopcock and the bore of the tubing should measure at least 4 mm. A check valve or water trap, or both, is suggested for the connection to the aspirator.

FIG. 1 Apparatus Assembly for the Water-Retention Test

uniform spacing adjacent to the rim of the dish and with the long axis of the tamping face held at right angles to the radius of the dish. Apply the remaining five tamping strokes at random points distributed over the central area of the dish. The tamping pressure shall be just sufficient to ensure filling of the dish. On completion of the tamping, the top of the mortar should extend slightly above the rim of the dish. Smooth off the mortar by drawing the flat side of the straightedge (with the leading edge slightly raised) across the top of the dish. Then cut off the mortar to a plane surface flush with the rim of the dish by drawing the straightedge with a sawing motion across the top of the dish in two cutting strokes, starting each cut from near the center of the dish. If the mortar is pulled away from the side of the dish during the process of drawing the straightedge across the dish, gently press the mortar back into contact with the side of the dish using the tamper.

18.2.3 Turn the stopcock to apply the vacuum to the funnel. The time elapsed from the start of mixing the cement and water to the time of applying the vacuum shall not exceed 8 min. After suction for 60 s, quickly turn the stopcock to expose the funnel to atmospheric pressure. Immediately slide the perforated dish off from the funnel, touch it momentarily on a damp cloth to remove droplets of water, and set the dish on the table. Then, using the bowl scraper (rubber scraper as used in Practice C 305), plow and mix the mortar in the dish for 15 s. Upon completion of mixing, place the mortar in the flow mold and determine the flow. The entire operation shall be carried

out without interruption and as quickly as possible, and shall be completed within an elapsed time of 11 min after the start of mixing the cement and water for the first flow determination. Both flow determinations shall be made in accordance with Test Method C 109/C 109M.

18.3 Calculation—Calculate the water retention value for the mortar as follows:

$$\text{Water retention value} = (A/B) \times 100 \quad (3)$$

where:

- A = flow after suction, and
- B = flow immediately after mixing.

19. Storage

19.1 The cement shall be stored in such a manner as to permit easy access for the proper inspection and identification of each shipment, and in a suitable weathertight building that will protect the cement from dampness and minimize warehouse set.

20. Inspection

20.1 Every facility shall be provided to the purchaser for the necessary inspection and sampling.

20.2 All packages shall be in good condition at the time of inspection.

ASTM C 91

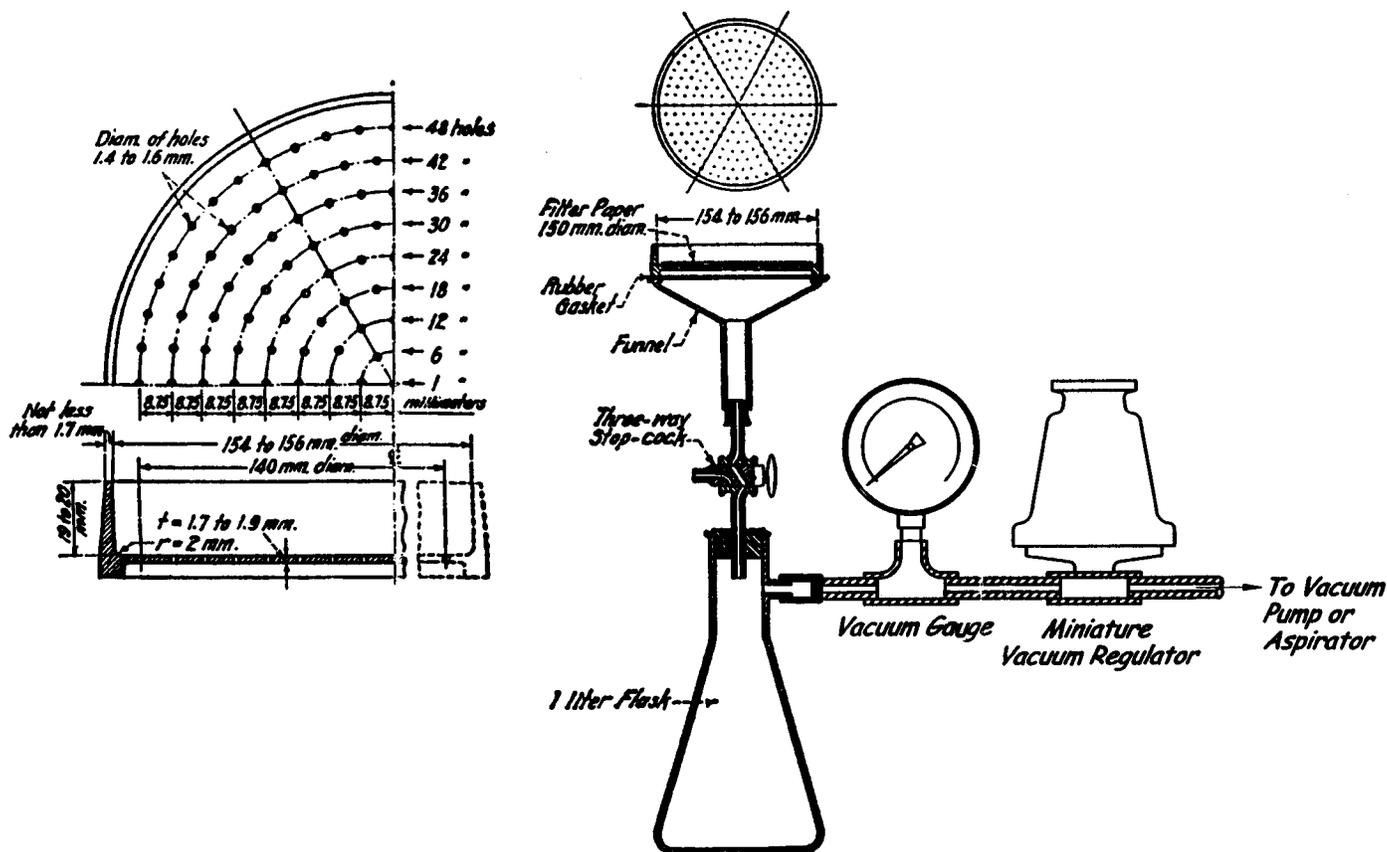

FIG. 2 Alternate Apparatus Assembly for the Water-Retention Test

21. Rejection

21.1 At the option of the purchaser, the cement shall be rejected if it fails to meet any of the requirements of this specification.

21.2 At the option of the purchaser, packages more than 2 % below the mass marked thereon shall be rejected. At the option of the purchaser, the entire shipment represented shall be rejected if the average mass of packages in any shipment as shown by weighing fifty packages taken at random is less than that marked on the packages.

21.3 At the option of the purchaser, cement remaining in storage prior to shipment for a period greater than six months after testing shall be retested and, at the option of the purchaser shall be rejected if it fails to meet any of the requirements of this specification.

22. Manufacturer's Certification

22.1 Upon request of the purchaser in the contract or order, a manufacturer's report shall be furnished at the time of

shipment stating the results of the tests made on samples of the material taken during production or transfer and certifying that the applicable requirements of this specification have been met.

23. Packaging and Package Marking

23.1 When masonry cement is delivered in packages, the brand, name of the manufacturer, type of masonry cement, and net mass of the package in kilograms (see Note 2) shall be indicated plainly thereon. Similar information shall be provided in the shipping documents accompanying the shipment of masonry cement in bulk.

NOTE 2—To facilitate the change to SI units, a standard SI package size of 32 kg for Type N, 34 kg for Type S, and 36 kg for Type M will provide convenient mass increments reasonably similar to the traditional 70-, 75-, and 80-lb packages.

24. Keywords

24.1 masonry; masonry cement; mortar

The American Society for Testing and Materials takes no position respecting the validity of any patent rights asserted in connection with any item mentioned in this standard. Users of this standard are expressly advised that determination of the validity of any such patent rights, and the risk of infringement of such rights, are entirely their own responsibility.

This standard is subject to revision at any time by the responsible technical committee and must be reviewed every five years and if not revised, either reapproved or withdrawn. Your comments are invited either for revision of this standard or for additional standards and should be addressed to ASTM Headquarters. Your comments will receive careful consideration at a meeting of the responsible technical committee, which you may attend. If you feel that your comments have not received a fair hearing you should make your views known to the ASTM Committee on Standards, at the address shown below.

**NOTICE: This standard has either been superseded and replaced by a new version or discontinued.
Contact ASTM International (www.astm.org) for the latest information.**



This standard is copyrighted by ASTM, 100 Barr Harbor Drive, PO Box C700, West Conshohocken, PA 19428-2959, United States. Individual reprints (single or multiple copies) of this standard may be obtained by contacting ASTM at the above address or at 610-832-9585 (phone), 610-832-9555 (fax), or service@astm.org (e-mail); or through the ASTM website (www.astm.org).