



Designation: C 955 – 01

Standard Specification for Load-Bearing (Transverse and Axial) Steel Studs, Runners (Tracks), and Bracing or Bridging for Screw Application of Gypsum Panel Products and Metal Plaster Bases¹

This standard is issued under the fixed designation C 955; the number immediately following the designation indicates the year of original adoption or, in the case of revision, the year of last revision. A number in parentheses indicates the year of last reapproval. A superscript epsilon (ϵ) indicates an editorial change since the last revision or reapproval.

1. Scope *

1.1 This specification covers steel studs, runners (tracks), and bracing or bridging (with a base metal thickness range of not less than 0.0329 in. (0.836 mm)) for screw application of gypsum panel products and metal plaster bases in load-bearing (transverse and axial) construction assemblies. Steel of lesser thickness shall be permitted in additional engineered products.

1.2 The values stated in inch-pound units are to be regarded as the standard. The SI (metric) values given in parentheses are provided for information purposes only.

1.3 The following precautionary caveat pertains only to the test method portion, Section 8, of this specification: *This standard does not purport to address all of the safety concerns, if any, associated with its use. It is the responsibility of the user of this standard to establish appropriate safety and health practices and determine the applicability of regulatory limitations prior to use.*

2. Referenced Documents

2.1 ASTM Standards:

A 653/A 653M Specification for Steel Sheet, Zinc-Coated (Galvanized) or Zinc-Iron Alloy-Coated (Galvannealed) by the Hot-Dipped Process²

A 792/A 792M Specification for Steel Sheet, 55 % Aluminum-Zinc Alloy-Coated by the Hot-Dip Process²

A 875/A 875M Specification for Steel Sheet, Zinc-5 % Aluminum Alloy-Coated by the Hot-Dip Process²

A 1003 Specification for Steel Sheet, Carbon, Metallic and Non-Metallic Coated for Cold-Formed Framing Members²

C 36 Specification for Gypsum Wallboard³

C 954 Specification for Steel Drill Screws for the Application of Gypsum Panel Products or Metal Plaster Bases to Steel Studs from 0.033 in. (0.84 mm) to 0.112 in. (2.84 mm) in Thickness³

2.2 AISI Standard:

Specification for the Design of Cold-Formed Steel Structural Members⁴

2.3 ISO Standard:

ISO 9223 Corrosion of Metals and Alloys—Corrosivity of Atmospheres—Classification⁵

3. Terminology

3.1 *Definitions:* Definitions shall be in accordance with Terminology C 11.

3.2 Definitions of Terms Specific to This Standard:

3.2.1 *members, n*—studs, runners, tracks, bracing, bridging, accessories or other items manufactured in accordance with this standard.

3.2.2 *structural member, n*—a member in a steel framed system in which the loading exceeds any of the following conditions: a transverse load of 20 lbf/ft (290 N/m) of member length, or an axial load, exclusive of sheathing, of 200 lbf (890 N) per member.

4. Materials and Manufacture

4.1 The mechanical properties of the steel shall meet the requirements of the AISI Specification for the Design of Cold-Formed Steel Structural Members.

4.2 The minimum steel thickness (base steel) shall be not less than 0.0329 in. (0.84 mm).

4.3 Individual measurements before the application of protective coating shall be not less than 95 % of the specified design thickness.

4.4 Members shall have a protective coating conforming to Specification A 653/A 653M, G60 minimum, or equivalent corrosion resistance, or shall have a rust-inhibitive coating providing equivalent corrosion resistance.

4.5 Edges of members shall be manufactured to minimize burrs and sharp edges.

4.6 Factory punch-outs, when provided, shall be located along the centerline of the webs of members and shall have

¹ This specification is under the jurisdiction of ASTM Committee C11 on Gypsum and Related Building Materials and Systems and is the direct responsibility of Subcommittee C11.02 on Specifications and Test Methods for Accessories and Related Products.

Current edition approved Sept. 10, 2001. Published November 2001. Originally published as C 955 - 81. Last previous edition C 955 - 00a.

² *Annual Book of ASTM Standards*, Vol 01.06.

³ *Annual Book of ASTM Standards*, Vol 04.01.

⁴ Available from the American Iron and Steel Institute, 1000 16th St., N.W., Washington, DC 20036.

⁵ Available from International Organization for Standardization, 1, Rue de Varembe, Case Postale 56, CH-1211, Geneva 20, Switzerland.

***A Summary of Changes section appears at the end of this standard.**

center-to-center spacing of not less than 24 in. (610 mm). Web punch-outs maximum width shall be the lesser of 0.5 times the member depth, d , or 2½ in. (64 mm). Web punch-out length shall not exceed 4½ in. (114 mm). Minimum distance between the end of the member and the near edge of the web punch-out shall be 10 in. (254 mm). The size of the factory punch-outs shall not exceed the size used in design and the center-to-center spacing shall not be less than that used in design.

4.7 The sectional properties of members shall be computed in accordance with the AISI Specification for the Design of Cold-Formed Steel Structural Members.

5. Performance Requirements

5.1 When tested in accordance with Section 8, members shall be capable of pulling the head of the screw below the surface of the gypsum panel product without spin out (see Fig. 1).

6. Dimensions and Permissible Variations

6.1 Data for calculating design performance shall be supplied by the manufacturer.

6.2 The width of the surface to which the sheathing board is attached shall be not less than 1¼ in. (32 mm).

6.3 Runners (track) shall be formed in a U-shaped configuration, having a depth compatible with that of the studs of the same nominal size.

6.4 Minimum height of runner (track) flanges shall be ¾ in. (19 mm).

6.5 Members shall be manufactured within the limits as shown in Table 1 and Fig. 2.

6.6 Bracing and bridging shall have configuration and steel thickness to provide secondary support for the studs in accordance with the AISI Specification for the Design of Cold-Formed Steel Structural Members.

7. Workmanship, Finish, and Appearance

7.1 The steel members shall be free of defects that interfere with the purpose for which they are intended.

8. Penetration Test

8.1 *Significance and Use*—This test method provides a procedure for evaluating the member’s ability to pull the head

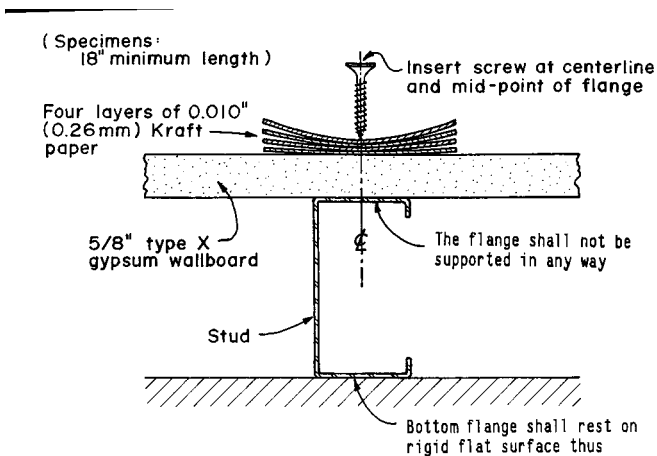

FIG. 1 Studs

TABLE 1 Manufacturing Tolerances

Dimension ^A	Item Checked	Structural Studs, in. (mm)	Structural Track, in. (mm)
A	length	+ 3/32 (2.38) - 3/32 (2.38)	+ 1/2 (12.7) - 1/4 (6.35)
B ^B	web width	+ 1/32 (0.79) - 1/32 (0.79)	+ 1/32 (0.79) + 1/8 (3.18)
C	flare	+ 1/16 (1.59)	+ 0 (0)
D	overbend	- 1/16 (1.59)	- 3/32 (2.38)
	hole center	+ 1/16 (1.59)	NA
	width	- 1/16 (1.59)	
E	hole center	+ 1/4 (6.35)	NA
	length	- 1/4 (6.35)	
F	crow	+ 1/16 (1.59) - 1/16 (1.59)	+ 1/16 (1.59) - 1/16 (1.59)
G	camber	1/32 per ft (0.79) 1/2max (12.7)	1/32 per ft (0.79) 1/2 max (12.7)
H	bow	1/32 per ft (0.79) 1/2max (12.7)	1/32 per ft (0.79) 1/2max (12.7)
I	twist	1/32 per ft (0.79) 1/2max (12.7)	1/32 per ft (0.79) 1/2 max (12.7)

^A All measurements shall be taken not less than 1 ft (305 mm) from the end.
^B Outside dimension for stud; inside for track.

of a screw below the surface of the gypsum panel product. It shall be used to determine compliance with this specification. The degree of performance of this test method with service performance has not been determined.

8.2 *Apparatus shall satisfy the following:*

8.2.1 *Electric Drill* capable of 2500 r/min (free spindle speed), supplied with a screw driving bit to fit the screw used in the test.

8.3 *Materials shall satisfy the following:*

8.3.1 *Gypsum Board*, Type X, 5/8 in. (16 mm) thick.

8.3.2 *Screws*—Specification C 954, 1 in. (25.4 mm) long.

8.3.3 *Kraft Paper*, 0.010 in. (0.25 mm) thick.

8.4 *Sampling*—One member shall be selected from each bundle or package but not more than ten from any one shipment for testing.

8.5 *Specimen Preparation:*

8.5.1 Each member to be tested shall be cut into test specimens not less than 18 in. (460 mm) long.

8.5.2 For each test, one piece of gypsum board, 6-in. (152-mm) square, shall be cut not less than 12 in. (305 mm) from the edge or end of the wallboard.

8.5.3 For each test, four pieces of kraft paper, 2-in. (51-mm) square shall be cut.

8.6 *Number of Tests and Retests:*

8.6.1 Five specimens of members shall be tested.

8.6.2 If more than one test specimen fails to meet the requirements, two more test specimens shall be chosen for retesting.

8.7 *Report*—Report shall indicate all specimens meeting the requirements of this specification if the screw penetrated the steel and the screw did not spin out; or shall indicate all specimens failing if the screw did not penetrate the steel, or the screw spun out.

8.8 *Precision and Bias*—No statement is made about either the precision or bias of this test method since the result merely states whether or not there is conformance to the criteria for success specified in the procedure.

9. Inspection

9.1 Inspection of the members shall be agreed upon between

ASTM C 955

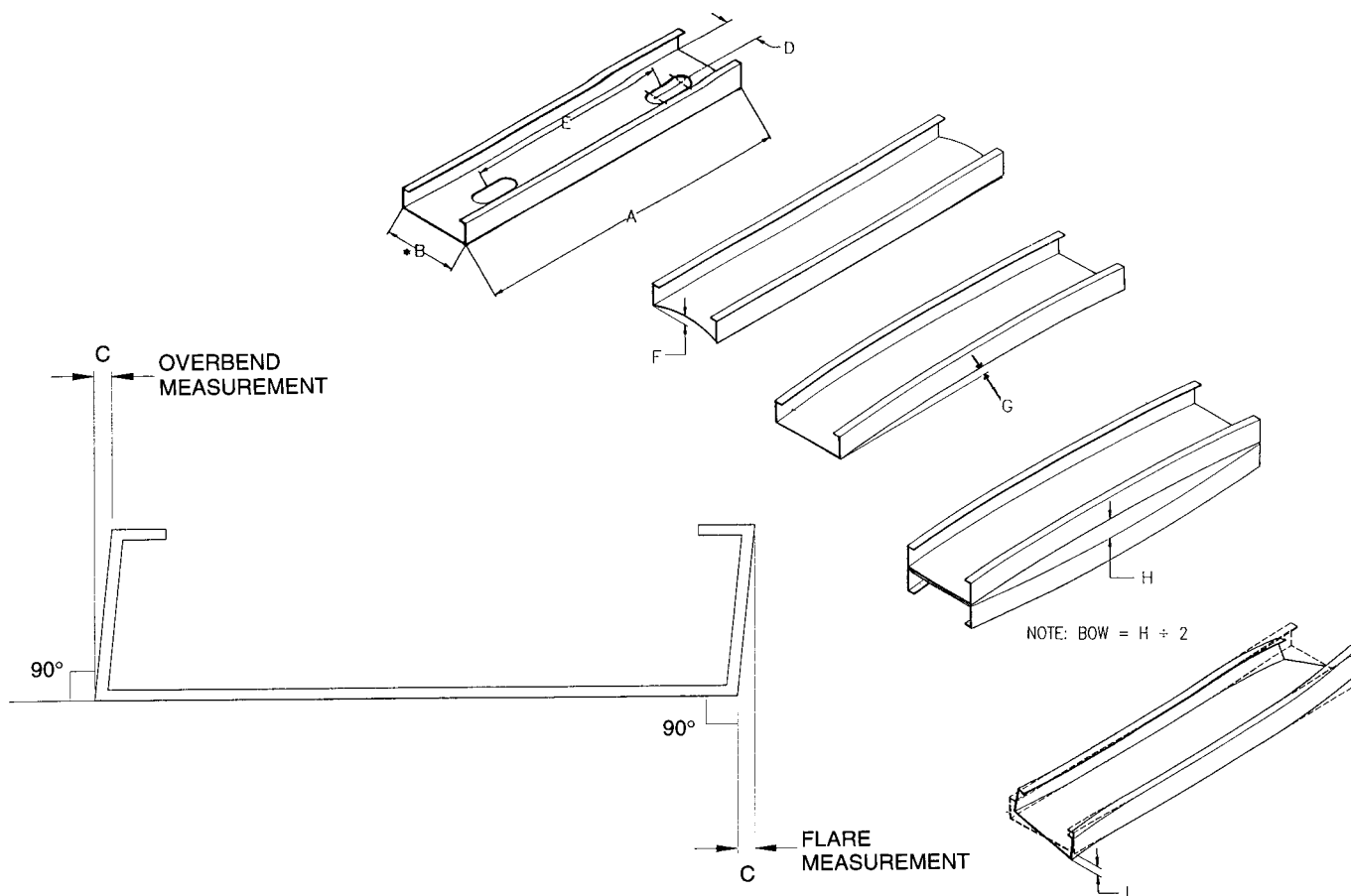

FIG. 2 Manufacturing Tolerances

the purchaser and the producer or supplier as part of the purchase agreement.

10. Rejection

10.1 When specified in the purchase agreement, members that fail to conform to the requirements of this specification shall be rejected. Rejection shall be reported to the producer or supplier promptly and in writing. The notice of rejection shall contain a statement documenting how the member has failed to conform to the requirements of this specification and the purchase agreement.

11. Certification

11.1 When specified in the purchase agreement, a producer's or supplier's report shall be furnished at the time of shipment certifying that the product is in compliance with this specification.

12. Marking and Identification

12.1 Groups of like members shall be marked with a label,

or a tag attached thereto. Marking shall include the rollformer's identification (name, logo, or initials), length, quantity, and rollformer's member designator including member depth, flange size, and minimum steel thickness in mils or inches exclusive of protective coating.

12.2 In addition to the marking referenced in 12.1, individual members shall have a legible label, stencil, or embossment, at a maximum distance of 48 in. (1220 mm) on center, on the web of the member, with the following minimum information:

12.2.1 The rollformer's identification (that is, name, logo, or initials).

12.2.2 The minimum steel thickness, in mils or inches, exclusive of protective coatings.

12.2.3 The minimum yield strength in kip per square inch (megapascals).



TABLE 2 Coating Designations

Coating Classification	Coating Designator	Minimum Coating Requirements			
		Zinc-Coated ^A	Zinc Iron ^B	55 % Al-Zinc ^C	Zinc-5 % ^D
Metallic Coated	CP 40	G 40	A 40	AZ 50	GF 30
	CP 60	G 60	A 60	AZ 50	GF 30
	CP 90	G 90	Not Applicable	AZ 50	GF 45
Painted Metallic	PM	The metallic coated substrate shall meet the requirements of metallic coated. In addition, the paint film shall have a minimum thickness of 0.5 mil per side (primer plus topcoat) with a minimum primer thickness of 0.1 mil per side. ^E			
Painted	PTD	Non-metallic coated substrate shall be painted after roll forming and shall have a minimum paint thickness of 1.0 mil on all surfaces including edges. Use of painted product is limited to environments where the rate of corrosion is low; typically areas such as interiors of buildings and areas of low rainfall and low humidity as defined by ISO 9223, Category 1 and 2. ^{E,F}			

^A Zinc-coated steel sheet as described in Specification A 653/A 653M.

^B Zinc-iron alloy-coated steel sheet as described in Specification A 653/A 653M.

^C 55 % Aluminum-zinc alloy-coated steel sheet as described in Specification A 792/A 792M.

^D Zinc-5 % aluminum alloy-coated steel sheet as described in Specification A 875/A 875M.

^E In accordance with the requirements of A 1003.

^F ISO International Standard 9223.

12.2.4 The minimum protective coating shall be indicated with the appropriate coating designator in accordance with Table 2.

12.3 Individual members or bundles of like members shall be color-coded in accordance with Table 3.

13. Protection

13.1 Material shall be protected during shipment and storage as required. When specified in the purchase order, the stud, runner, bracing, or bridging shall be packaged in accordance with the purchaser's instructions.

TABLE 3 Color Codes for Members

Color	Minimum Base Metal Thickness, mils	Minimum Decimal Equivalent,	
		in.	(mm)
White	33	0.0329	(0.836)
Yellow	43	0.0428	(1.087)
Green	54	0.0538	(1.367)
Orange	68	0.0677	(1.720)
Red	97	0.0966	(2.454)
Blue	118	0.1180	(2.997)

14. Keywords

14.1 runners; screws; section properties; studs; thickness

SUMMARY OF CHANGES

This section identifies the location of changes to this specification that have been incorporated since the last issue. Committee C11 has highlighted those changes that affect the technical interpretation or use of this specification.

(1) Replaced existing paragraph 12.2.4 with new paragraph 12.2.4.

(2) Revised Section 2.

(3) Included new Table 2.

The ASTM International takes no position respecting the validity of any patent rights asserted in connection with any item mentioned in this standard. Users of this standard are expressly advised that determination of the validity of any such patent rights, and the risk of infringement of such rights, are entirely their own responsibility.

This standard is subject to revision at any time by the responsible technical committee and must be reviewed every five years and if not revised, either reapproved or withdrawn. Your comments are invited either for revision of this standard or for additional standards and should be addressed to ASTM International Headquarters. Your comments will receive careful consideration at a meeting of the responsible technical committee, which you may attend. If you feel that your comments have not received a fair hearing you should make your views known to the ASTM Committee on Standards, at the address shown below.

This standard is copyrighted by ASTM International, 100 Barr Harbor Drive, PO Box C700, West Conshohocken, PA 19428-2959, United States. Individual reprints (single or multiple copies) of this standard may be obtained by contacting ASTM at the above address or at 610-832-9585 (phone), 610-832-9555 (fax), or service@astm.org (e-mail); or through the ASTM website (www.astm.org).