



Designation: C 1399 – 04~~2~~

## Test Method for Obtaining Average Residual-Strength of Fiber-Reinforced Concrete<sup>1</sup>

This standard is issued under the fixed designation C 1399; the number immediately following the designation indicates the year of original adoption or, in the case of revision, the year of last revision. A number in parentheses indicates the year of last reapproval. A superscript epsilon ( $\epsilon$ ) indicates an editorial change since the last revision or reapproval.

### 1. Scope

1.1 This test method covers the determination of residual strength of a fiber-reinforced concrete test beam. The average residual strength is computed for using specified beam deflections beginning after the that are obtained from a beam that has been cracked in a standard manner. The test provides data needed to obtain that portion of the load-deflection curve beyond which a significant amount of cracking damage has occurred and it provides a measure of post-cracking strength, as such strength is affected by the use of fiber-reinforcement.

1.2 *This standard does not purport to address all of the safety concerns, if any, associated with its use. It is the responsibility of the user of this standard to establish appropriate safety and health practices and determine the applicability of regulatory limitations prior to use.*

1.3 The values stated in SI units are to be regarded as the standard. The values in parentheses are for information only.

### 2. Referenced Documents

#### 2.1 ASTM Standards:

C 31 Practice for Making and Curing Concrete Test Specimens in the Field<sup>2</sup>

C 42 Test Method for Obtaining and Testing Drilled Cores and Sawed Beams of Concrete<sup>2</sup>

C 78 Test Method for Flexural Strength of Concrete (Using Simple Beam with Third-Point Loading)<sup>2</sup>

C 172 Practice for Sampling Freshly Mixed Concrete<sup>2</sup>

C 192 Practice for Making and Curing Concrete Test Specimens in the Laboratory<sup>2</sup>

C 823 Practice for Examination and Sampling of Hardened Concrete in Constructions<sup>2</sup>

C 1018 Test Method for Flexural Toughness and First Crack Strength of Fiber-Reinforced Concrete (Using Beam With Third-Point Loading)<sup>2</sup>

### 3. Terminology

#### 3.1 Definitions of Terms Specific to This Standard:

3.1.1 *deflection*—mid-span deflection of the test beam obtained in a manner that excludes deflection caused by the following: (1) the flexural test apparatus, (2) crushing and seating of the beam at support contact points, and (3) torsion of the beam; sometimes termed net deflection.

3.1.2 *initial loading curve*—the load-deflection curve obtained by testing an assembly that includes both the test beam and a specified steel plate (Fig. 1); plotted to a deflection of at least 0.25 mm (0.010 in.) (Fig. ~~2~~ 3).

3.1.3 *reloading curve*—the load-deflection curve obtained by reloading and retesting the pre-cracked beam, that is, after the initial loading but without the steel plate. (Fig. ~~2~~ 3)

3.1.4 *reloading deflection*—deflection measured during the reloading of the cracked beam and with zero deflection referenced to the start of the reloading.

3.1.5 *residual strength*—the flexural stress on the cracked beam section obtained by calculation using loads obtained from the reloading curve at specified deflection values (see Note 1).

NOTE 1—Residual strength is not a true stress but an engineering stress computed using the flexure formula for linear elastic materials and gross (uncracked) section properties.

3.1.6 *average residual strength*—the average stress-carrying ability of the cracked beam that is obtained by calculation using the residual strength at four specified deflections.

<sup>1</sup> This specification is under the jurisdiction of ASTM Committee C09 on Concrete and Concrete Aggregates and is the direct responsibility of Subcommittee C09.42 on Fiber-Reinforced Concrete.

Current edition approved Nov. August 10, 2004~~2~~. Published January October 2002. Originally published as C 1399-98. Last previous edition C 1399-00~~1~~.

<sup>2</sup> *Annual Book of ASTM Standards*, Vol 04.02.

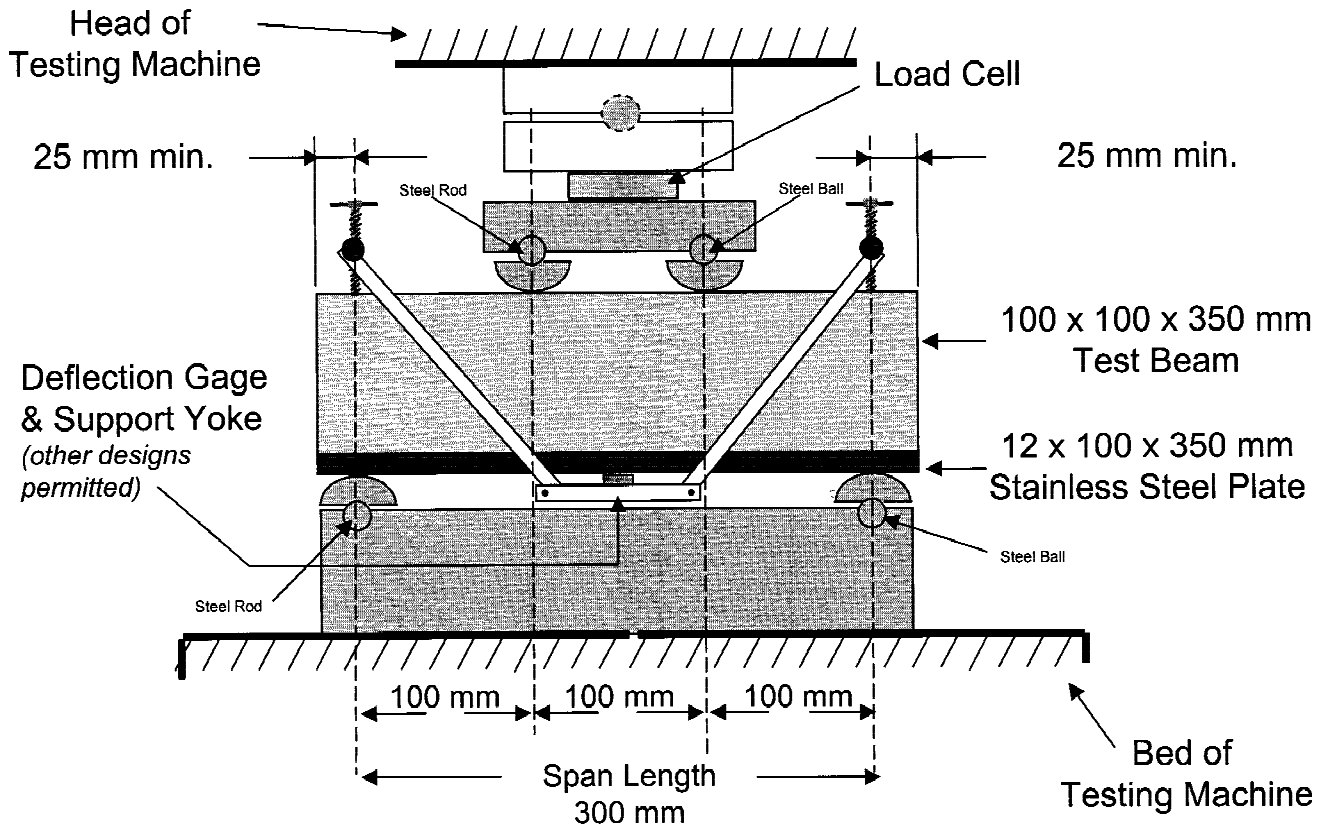

Note: All dimensions are  $\pm 2\%$

FIG. 1 Diagram Schematic View of a Suitable Apparatus for Residual Strength Test of Deflection Reaction Gage Support Frame is Seated on the Beam

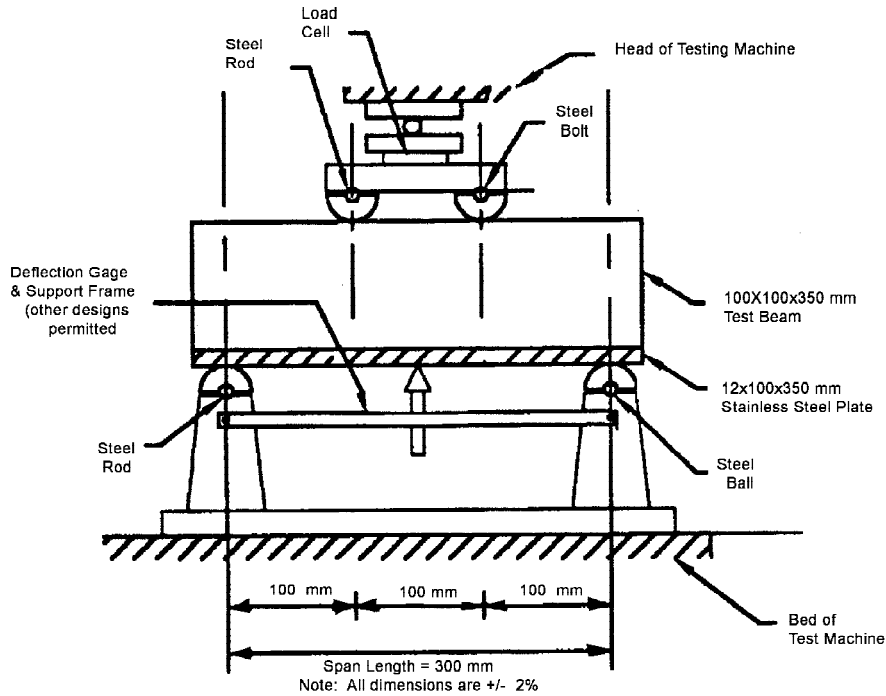

Note: All dimensions are  $\pm 2\%$

FIG. 2 Schematic of a Suitable Apparatus Where the Deflection Gage Support Frame is Clamped to the Beam Supports

#### 4. Summary of Test Method

4.1 Cast or sawed beams of fiber-reinforced concrete are cracked using the third-point loading apparatus specified in Test

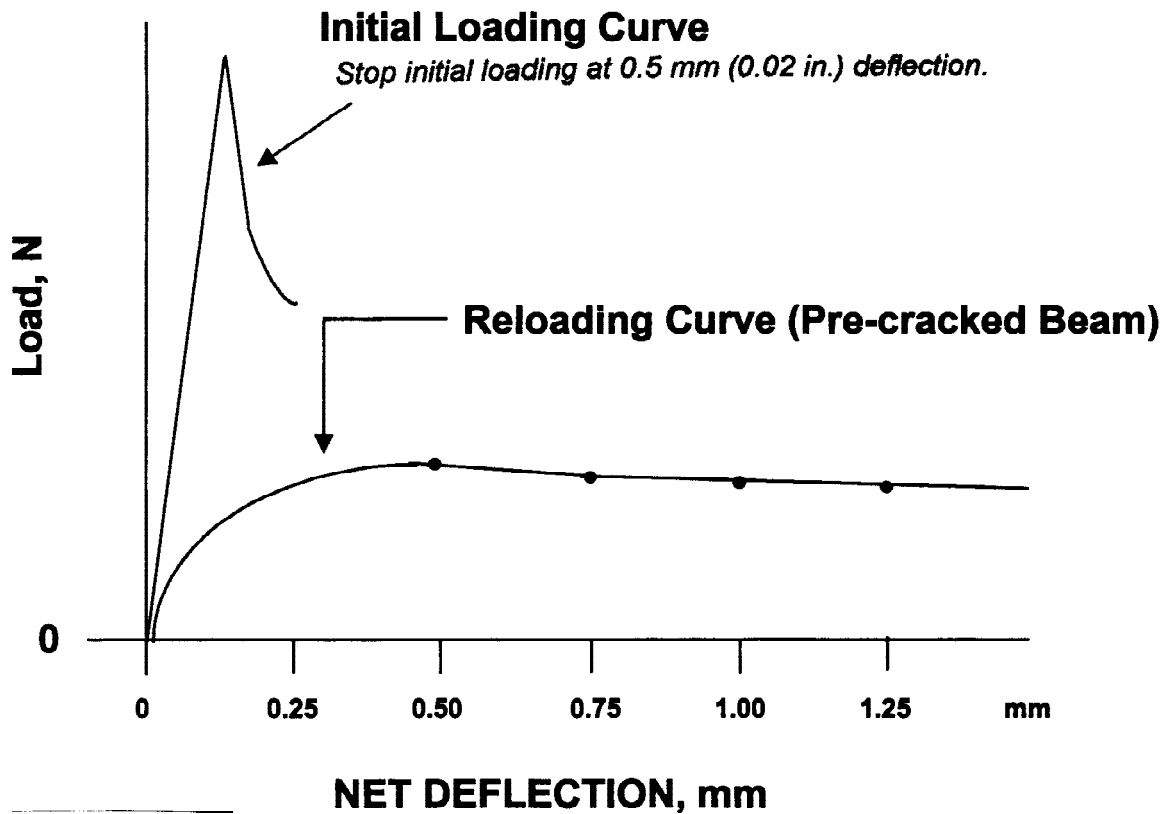

FIG. 2 3 Load-Deflection Curves

Method C 78 modified by a steel plate used to assist in support of the concrete beam during an initial loading cycle (Fig. 1). The steel plate is used to help control the rate of deflection when the beam cracks. After the beam has been cracked in the specified manner, the steel plate is removed and the cracked beam is reloaded to obtain data to plot a reloading load–deflection curve. Load values at specified deflection values on the reloading curve are averaged and used to calculate the average residual strength of the beam.

## 5. Significance and Use

5.1 This test method provides a quantitative measure useful in the evaluation of the performance of fiber–reinforced concrete. It allows for comparative analysis among beams containing different fiber types, including materials, dimension and shape, and different fiber contents. Results can be used to optimize the proportions of fiber–reinforced concrete mixtures, to determine compliance with construction specifications, to evaluate fiber–reinforced concrete which has been in service, and as a tool for research and development of fiber–reinforced concrete (see Note 2).

NOTE 2—Banthia and Dubey<sup>3</sup> compared results using this test method with residual strengths at the same net deflections from Test Method C 1018 on 45 beams with a single fiber configuration at proportions of 0.1, 0.3, and 0.5 % by volume and reported an average 6.4 % lower than Test Method C 1018 test results.

5.2 Test results are intended to reflect either consistency or differences among variables used in proportioning the fiber–reinforced concrete to be tested, including fiber type (material), fiber size and shape, fiber amount, beam preparation (sawed or molded), and beam conditioning.

5.3 In molded beams fiber orientation near molded surfaces will be affected by the process of molding. For tests of fiber–reinforced concrete containing relatively rigid or stiff fibers of length greater than 40 mm (1.5 in.), the use of sawed beams cut from samples which had initially a with an initial width and depth of at least 3 times the length of the fiber is recommended to minimize effects of fiber orientation.

## 6. Apparatus

6.1 *Either Screw Gear or Hydraulic Testing Apparatus*, with the ability to control the rate of motion of the loading head and meeting the requirements of Test Method C 78. A load cell with a 44.5 kN capacity (10,000 lbf) will generally be required. Closed–loop feed–back controlled deflection apparatus is not required.

<sup>3</sup> Banthia, N. and Dubey, A., “Measurement of Flexural Toughness of Fiber Reinforced Concrete Using a Novel Technique, Part I: Assessment and Calibration,” In Press, *Materials Journal*, American Concrete Institute.

6.2 *Flexural-Loading Beam-Support Apparatus*, conforming to the requirements of Test Method C 78.

6.3 *Load and Deflection-Measuring Devices*, such as load cells and electronic transducers, capable of producing electronic analog signals and having support apparatus located and arranged in a manner that provide determination of applied load and mid-span deflection (see 3.1.5) of the beam. Measure deflection using a device capable of measuring net deflection at the beam mid-span with a minimum resolution of 0.025 mm (0.001 in.) by one of the following alternative methods (see Note 3).

NOTE 3—The deflection measurement requires care in the arrangement of displacement transducers in order to minimize extraneous contributions such as might be caused by seating or twisting of the specimen. A suggested method Experience has shown that apparatus designed to support deflection measuring devices that eliminate extraneous deflections, except that due to possible crushing of concrete at the beam supports, is acceptable. Methods to accomplish this measurement use a spring-loaded electronic displacement transducers mounted on a suspension-yoke frames or support frames as is shown in Fig. 1 and Fig. 2, respectively.

6.3.1 *Three Electronic Transducers*, mounted on a support frame. The support frame positions the transducers along the centerline of the top surface of the test beam at locations so as to contact the beam at mid-span and each support location. Average the measured support deflections and subtract this value from the recorded mid-span deflection to obtain the net deflection.

6.3.2 *Two Electronic Transducers*, mounted on a support frame. The support frame either (1) surrounds the test beam and is clamped to the sides of the beam at points on a line passing vertically through the beam support locations, or (2) is seated on top of the beam and is itself supported at points directly over the beam supports, or (3) surrounds the beam and is clamped to the beam supports. In either each case one transducer is located on each side of the test beam at mid-span, recording deflection between the mounted transducers and contact points that are rigid attachments located on the beam at the center of the span. The average of the two transducer measurements is are the net deflection.

6.3.3 *One Electronic Transducer*, mounted on a support frame. The support frame either (1) surrounds the test beam and is clamped to the sides of the beam at points on a line passing vertically through the beam support locations, or (2) is seated on top of the beam and is itself supported at points directly over the beam supports, or (3) surrounds the beam and is clamped to the beam supports. The transducer is positioned to contact the specimen at mid span along the longitudinal centerline of the beam and is located either below or above the beam. (see Note 4)

NOTE 4—If the deflection is measured at the bottom of the beam, erroneous measurements may occur if a crack develops at the point of measurement. This problem can be avoided by using a transducer probe that is approximately 6 mm wide so as to span any potential crack.

6.4 *Data Acquisition Equipment*, capable of simultaneously recording data from the load and deflection transducers by either of the following alternative methods.

6.4.1 *X-Y Plotter*, driven by analog signals from load and deflection transducers to record the load-deflection curve.

6.4.2 *Analog Signal Sampling and Digital Conversion Using Automatic Data Acquisition Equipment With a Minimum Sampling Frequency of 2.5 Hz*, to record load and corresponding deflection values from which load-deflection curves can be produced.

6.5 *Stainless Steel Plate*, nominally 100 by 12 by 350 mm (4 by ½ by 14 in.) (see Note 4)-5)

NOTE 45—Depending upon the chosen method for obtaining net deflection during testing, a center hole may be placed in the steel plate to accommodate placing a displacement transducer probe directly against the bottom of the test beam.

6.6 *Mechanical Dial Gage*, with 0.025 mm (0.001 in.) resolution.

6.7 *Magnetic-Mount Dial Gage Holder*.

6.8 *Beam Molds*, conforming to the requirements of Practice C 192 that will produce 100 mm by 100 mm by 350 mm (4 in. by 4 in. by 14 in.) beams.

## 7. Sampling, Test Beams, and Test Units

7.1 Prepare a set of at least three beams from each sample of fresh or hardened concrete.

7.2 *Freshly Mixed Concrete*:

7.2.1 Obtain samples of freshly mixed fiber-reinforced concrete in accordance with Practice C 172.

7.2.2 Mold beams in accordance with Practice C 31 or Practice C 192 and cast in one layer using a vibrating table for consolidation. Internal vibration or rodding may produce non-uniform fiber distribution.

7.2.3 Cure samples for a minimum of 7 days in accordance with the standard curing procedure in Practice C 31 or the procedure in Practice C 192. Use the same curing time when comparison between or among laboratories is desired.

7.3 *Hardened Concrete*:

7.3.1 Select samples of hardened fiber-reinforced concrete from structures in accordance with Practice C 823.

7.3.2 Prepare and condition sawed beams in accordance with Test Method C 42. The sawed beams shall have dimensions 100 mm by 100 mm by 350 mm (4 in. by 4 in. by 14 in.).

## 8. Procedure

8.1 Set the rate of platen or cross-head movement at  $0.65 \pm 0.15$  mm/min ( $0.025 \pm 0.005$  in./min.) before the beam is loaded (see Note 5)-6).

NOTE 56—When necessary use the mechanical dial gage to establish the setting for the rate of platen or cross-head movement.

8.2 Turn the beam on its side with respect to its position as molded and place on top of the steel plate to be loaded with the beam (see Note 6)-7).

NOTE 67—The purpose of the stainless steel plate is to support the test beam during the initial loading cycle to help control the expected high rate of deflection of the beam upon cracking.

8.3 Place the plate and beam on the support apparatus so that the steel plate is centered on the lower bearing blocks and the concrete beam is centered on the steel plate. Adjust the displacement transducer(s) according to the chosen apparatus for obtaining net deflection.

8.4 Ensure that the X–Y plotter or alternate data acquisition system is activated and responding to signals from all load and displacement transducers.

8.5 Begin loading the beam and steel plate combination at the set rate and continue loading until reaching a deflection of 0.5 mm (0.02 in.). If cracking has not occurred after reaching a deflection of 0.5 mm (0.02 in.) the test is invalid. The maximum load is not to be used to calculate modulus of rupture in accordance with Test Method C 78 as this load includes load carried by the steel plate as well as by the concrete beam.

8.6 In anticipation of reloading the cracked beam only, remove the steel plate and center the cracked beam on the lower bearing blocks retaining the same orientation as during the initial loading test cycle. Adjust the displacement transducer(s) to lightly contact the beam in accordance with the chosen method for obtaining net deflection so that readings will immediately be obtained upon beam reloading. Zero the deflection recording device.

8.7 Begin reloading at the specified rate used for the initial loading. Terminate the test at a deflection of 1.25 mm (0.050 in.) as measured from the beginning of reloading.

8.8 Measure the beam and crack location as in Test Method C 78.

## 9. Calculation

9.1 Calculate the average residual strength (ARS) for each beam to the nearest 0.01 MPa (2 psi) using the loads determined at reloading curve deflections of 0.50, 0.75, 1.00, and 1.25 mm (0.020, 0.030, 0.040, and 0.050 in.) as follows:

$$ARS = ((P_A + P_B + P_C + P_D) / 4) \times k \quad (1)$$

where:

- $k$  =  $L/bd^2$ , mm<sup>-2</sup> (in<sup>-2</sup>)
- $ARS$  = average residual strength, MPa (psi),
- $P_A+P_B+P_C+P_D$  = sum of recorded loads at specified deflections, N (lbf),
- $L$  = span length, mm (in.),
- $b$  = average width of beam, mm (in.), and
- $d$  = average depth of beam, mm (in.).

9.2 Calculate the mean ARS for each set of beams to the nearest 0.05 MPa (5 psi).

## 10. Report

10.1 The test report shall include the following information. If specific information is unknown at the time of the test then the word “UNKNOWN” shall ~~appear~~ be used.

- 10.1.1 Concrete mixture proportions.
- 10.1.2 Type and amount of fiber reinforcement.
- 10.1.3 Test beam information including:
  - 10.1.3.1 beam identification labels,
  - 10.1.3.2 type of beam (molded or sawed),
  - 10.1.3.3 average width of beam to the nearest 1.0 mm (0.05 in.),
  - 10.1.3.4 average depth of beam to the nearest 1.0 mm (0.05 in.),

**TABLE 1 Precision Data for Test Samples**

ARS (MPa)	Standard Deviation	Acceptable Range of Two Results	Acceptable Range Difference Between High and Low, Three Results
	(MPa)	(MPa)	(MPa)
Single Operator Precision:			
0.50	0.10	0.28	0.33
1.00	0.12	0.34	0.40
2.00	0.28	0.78	0.92
3.50	0.45	1.26	1.49
Multilaboratory Precision:			
0.50	0.22	0.62	0.73
1.00	0.21	0.59	0.69
2.00	0.41	1.15	1.35
3.50	0.55	1.54	1.82

10.1.3.5 beam age at time of test,

10.1.3.6 curing history and moisture condition at time of test, ~~and test,~~

10.1.3.7 defects in beam or abnormalities during testing;<sub>2</sub>

10.1.43.8 ~~Loads obtained upon reloading~~ at reloading deflections of 0.50, 0.75, 1.00, and 1.25 mm (0.020, 0.030, 0.040 and 0.050 in.);<sub>2</sub>

10.1.53.9 Average Residual Strength (ARS) for each beam to the nearest 0.01 MPa (2 psi);<sub>2</sub>

10.1.63.10 Plots of the reloading curves from which the average residual strengths (ARS) were determined, and

10.1.3.11 mean value of the ARS found for each set of beams to the nearest 0.05 MPa (5 psi).

## 11. Precision and Bias

11.1 *Precision*—Criteria for judging the acceptability of test results obtained for this test method are given in Table 1 (see Note 7); ~~8).~~

NOTE 78—The precision statements are based on tests conducted in ten laboratories on sets of three duplicate samples of four different mixtures.

11.2 *Bias*—The test method has no bias because the values determined can be defined only in terms of this test method.

## 12. Keywords

12.1 fiber-reinforced concrete; residual strength; flexure testing; post cracking strength

*ASTM International takes no position respecting the validity of any patent rights asserted in connection with any item mentioned in this standard. Users of this standard are expressly advised that determination of the validity of any such patent rights, and the risk of infringement of such rights, are entirely their own responsibility.*

*This standard is subject to revision at any time by the responsible technical committee and must be reviewed every five years and if not revised, either reapproved or withdrawn. Your comments are invited either for revision of this standard or for additional standards and should be addressed to ASTM International Headquarters. Your comments will receive careful consideration at a meeting of the responsible technical committee, which you may attend. If you feel that your comments have not received a fair hearing you should make your views known to the ASTM Committee on Standards, at the address shown below.*

*This standard is copyrighted by ASTM International, 100 Barr Harbor Drive, PO Box C700, West Conshohocken, PA 19428-2959, United States. Individual reprints (single or multiple copies) of this standard may be obtained by contacting ASTM at the above address or at 610-832-9585 (phone), 610-832-9555 (fax), or service@astm.org (e-mail); or through the ASTM website (www.astm.org).*