



Designation: C 1550 – 03a

Standard Test Method for Flexural Toughness of Fiber Reinforced Concrete (Using Centrally Loaded Round Panel)¹

This standard is issued under the fixed designation C 1550; the number immediately following the designation indicates the year of original adoption or, in the case of revision, the year of last revision. A number in parentheses indicates the year of last reapproval. A superscript epsilon (ϵ) indicates an editorial change since the last revision or reapproval.

1. Scope*

1.1 This test method covers the determination of flexural toughness of fiber-reinforced concrete expressed as energy absorption in the post-crack range using a round panel supported on three symmetrically arranged pivots and subjected to a central point load. The performance of specimens tested by this method is quantified in terms of the energy absorbed between the onset of loading and selected values of central deflection.

1.2 This test method provides for the scaling of results whenever specimens do not comply with the target thickness and diameter, as long as dimensions do not fall outside of given limits.

1.3 The values stated in SI units are to be regarded as the standard.

1.4 *This standard does not purport to address all of the safety concerns, if any, associated with its use. It is the responsibility of the user of this standard to establish appropriate safety and health practices and determine the applicability of regulatory limitations prior to use.*

2. Referenced Documents

2.1 *ASTM Standards:*

¹ This test method is under the jurisdiction of ASTM Committee C09 on Concrete and Concrete Aggregates and is the direct responsibility of Subcommittee C09.42 on Fiber-Reinforced Concrete.

Current edition approved ~~Jan.~~ June 10, 2003. Published ~~May~~ August 2003. Originally approved in 2002. Last previous edition approved in 2002~~3~~ as C 1550-02~~3~~.

***A Summary of Changes section appears at the end of this standard.**

C 125 Terminology Relating to Concrete and Concrete Aggregates²

C 670 Practice for Preparing Precision and Bias Statements for Test Methods for Construction Materials²

3. Terminology

3.1 *Definitions*—For definitions of terms used in this test method, refer to Terminology C 125.

3.2 *Definitions of Terms Specific to This Standard:*

3.2.1 *central deflection*—the net deflection at the center of the panel measured relative to a plane defined by the three pivots used to support the panel; this is a conditioned deflection that excludes extraneous deformations of the load train and local crushing of the panel at the point of load application and points of support.

3.2.2 *compliance*—a measure of the tendency of a structure to deflect under load, found as the inverse of stiffness or deflection divided by the corresponding load.

3.2.3 *load train*—those parts of a testing machine that experience load and undergo straining during a mechanical test, including the actuator, frame, support fixtures, load cell, and specimen.

3.2.4 *toughness*—the energy absorbed by the specimen equivalent to the area under the load-deflection curve between the onset of loading and a specified central deflection.

4. Summary of Test Method

4.1 Molded round panels of cast fiber-reinforced concrete or fiber-reinforced shotcrete are subjected to a central point load while supported on three symmetrically arranged pivots. The load is applied through a hemispherical-ended steel piston advanced at a prescribed rate of displacement. Load and deflection are recorded simultaneously up to a specified central deflection. The energy absorbed by the panel up to a specified central deflection is representative of the flexural toughness of the fiber-reinforced concrete panel.

5. Significance and Use

5.1 The post-crack behavior of plate-like, fiber-reinforced concrete structural members is well represented by a centrally loaded round panel test specimen that is simply supported on three pivots symmetrically arranged around its circumference. Such a test panel experiences bi-axial bending in response to a central point load and exhibits a mode of failure related to the *in situ* behavior of structures such as concrete slabs-on-grade, shotcrete tunnel linings, and shotcrete embankment stabilization linings. The post-crack performance of round panels subject to a central point load can be represented by the energy absorbed by the panel up to a specified central deflection. In this test method, the energy absorbed up to a specified central deflection is taken to represent the ability of a fiber-reinforced concrete to redistribute stress following cracking.

NOTE 1—The use of three pivoted point supports in the test configuration results in determinate out-of-plane reactions prior to cracking, however the support reactions are indeterminate after cracking due to the unknown distribution of flexural resistance along each crack. There is also a change in the load resistance mechanism in the specimen as the test proceeds, starting with predominantly flexural resistance and progressing to tensile membrane action around the center as the imposed deflection is increased. The energy absorbed up to a specified central deflection is related to the toughness of the material but is specific to this specimen configuration because it is also determined by the support conditions and size of the specimen. Selection of the most appropriate central deflection to specify depends on the intended application for the material. The energy absorbed up to 5 mm central deflection is applicable to situations in which the material is required to hold cracks tightly closed at low levels of deformation. Examples include final linings in underground civil structures such as railway tunnels that may be required to remain water-tight. The energy absorbed up to 40 mm is more applicable to situations in that the material is expected to suffer severe deformation *in situ* (for example, shotcrete linings in mine tunnels and temporary linings in swelling ground). Energy absorption up to intermediate values of central deflection can be specified in situations requiring performance at intermediate levels of deformation.

5.2 The motivation for use of a round panel with three supports is based on the within-batch repeatability found in laboratory³ and field experience.⁴ The consistency of the failure mode that arises through the use of three symmetrically arranged support pivots results in low within-batch variability in the energy absorbed by a set of panels up to a specified central deflection. The use of round panels also eliminates the sawing that is required to prepare shotcrete beam specimens.

5.3 The nominal dimensions of the panel are 75 mm in thickness and 800 mm in diameter. Thickness has been shown to strongly influence panel performance in this test, while variations in diameter have been shown to exert a minor influence on performance.⁵ Correction factors are provided to account for actual measured dimensions.

NOTE 2—The target dimensions of the panel specimen used in this test are held constant regardless of the characteristics of aggregate and fibers used in the concrete comprising the specimen. Post-crack performance may be influenced by size and boundary effects if large aggregate particles or long fibers

² Annual Book of ASTM Standards, Vol 04.02.

³ Bernard, E. S. "Correlations in the Behaviour of Fibre Reinforced Shotcrete Beam and Panel Specimens," *Materials and Structures*, RILEM, Vol 35, April 2002, pp. 156-164.

⁴ Hanke, S. A., Collis, A., and Bernard, E. S., "The M5 Motorway: An Education in Quality Assurance for Fibre Reinforced Shotcrete," *Shotcrete: Engineering Developments*, Bernard (ed.), Swets & Zeitlinger, Lisse, 2001, pp. 145-156.

⁵ Bernard, E. S. and Pircher, M., 2001, "The Influence of Thickness on Performance of Fiber-Reinforced Concrete in a Round Determinate Panel Test," *Cement, Concrete, and Aggregates*, CAGDP, Vol 23, No. 1, June 2001, pp. 27-33.

are used in the concrete. These influences are acknowledged and accepted in this test method because issues of size effect and fiber alignment arise in actual structures and no single test specimen can suitably model structures of all sizes. Differences in post-crack behavior exhibited in this test method can be expected relative to cast fiber-reinforced concrete members thicker than 100 mm. Because fiber alignment is pronounced in structures produced by shotcreting, and the maximum aggregate size in shotcrete mixtures is typically 10 mm, post-crack behavior in specimens tested by this method are more representative of *in situ* behavior when they are produced by spraying rather than casting concrete.

6. Apparatus

6.1 *Testing Machine*—The testing machine shall be capable of operating in a manner that produces a controlled and constant rate of increase of deflection of the specimen without the intervention of an operator. To avoid unstable behavior after cracking, the system stiffness of the testing machine inclusive of load frame, load cell (if used), and support fixture shall exceed that of the specimen. The system stiffness of the testing machine can be determined in accordance with the procedure described in Annex A1. A closed-loop testing machine in which the measured deflection of the center of the specimen is used to automatically control the rate of increase of deflection of the loading device is acceptable. A testing machine in which the displacement rate of the loading device is constant is also acceptable provided the load train stiffness exceeds the value listed above. Do not use a load-controlled test machine. The load-sensing device shall have a resolution sufficient to record load to ± 50 N.

NOTE 3—Although it is commonly believed that closed-loop control systems are capable of overcoming the disadvantages of a structurally compliant testing machine, this will depend on the speed and sensitivity of the feed-back loop and the mechanical response rate of the loading apparatus. A more reliable configuration comprises a displacement-controlled hydraulic actuator in a testing machine with high system stiffness. Alternately, a stiff screw-driven machine in which the displacement of the cross-head is advanced at a constant rate is also acceptable. This test method has been developed for use with displacement-controlled machines so that the high cost of closed-loop machines can be avoided. Experience has indicated that the redistribution of stress that occurs in fiber-reinforced concrete panels following cracking of the concrete matrix generally results in stable post-crack behavior provided a testing machine complying with the requirements of this section is used.

6.2 *Support Fixture*—The fixture supporting the panel during testing shall consist of any configuration that includes three symmetrically arranged pivot points on a pitch circle diameter of 750 mm capable of supporting a load of 100 kN without displacing in the radial direction by more than 0.5 mm relative to the central axis. The three supports must be restrained against radial or circumferential translation, and the pivots shall not restrict rotation of the panel fragments after cracking. The support fixture must be configured so that the specimen does not come into contact with any portion of the support fixture apart from the three pivots during a test. A photograph of a suggested design is shown in Fig. 1. The contact between the specimen and each pivot shall comprise a steel transfer plate with plan dimensions of approximately 40×50 mm with a spherical seat of about 4 mm depth machined into one surface to accept a ball pivot (see Fig. 2). The distance between the surface of the panel and the center of the pivot shall be 20 ± 2 mm. The diameter of the pivot ball shall be 16 ± 2 mm. Grease is permitted to reduce friction in the seat of each pivot, but rollers or grease are not permitted to reduce friction between the transfer plates and specimen.

6.3 *Deflection Measuring Equipment*—Determine the central deflection of the specimen relative to the support points in a manner that excludes extraneous deformations of the testing machine and support fixture. This is achieved by one of two methods. If the displacement of the tensile surface of the panel at the center is measured relative to the pivot supports, then no correction for extraneous deformations of the testing machine and support fixture need be made to the recorded deflections. If the movement of the loading piston relative to the crosshead of the testing machine is used to measure deflection, the deflection record must be adjusted to discount extraneous deformations. A method of adjusting the deflection record to account for extraneous deformations is given in the calculation section. Regardless of the method of deflection measurement selected, use a displacement transducer with a resolution sufficient to record deflection to ± 0.05 mm.

NOTE 4—All components of the load train in a test system experience deformation when the specimen is placed under load. If the deflection of the specimen is measured relative to the machine crosshead, then the deformation of the load train is included as extraneous deformations in the deflection record. Additional extraneous deformations may arise from local crushing of concrete under the load point (especially debris on the surface), or from crushing of any debris between the specimen and transfer plates. This second form of extraneous deformation usually results in curvature in the initial portion of the load-deflection curve.

NOTE 5—If the deflection of the center of the tensile surface of the specimen is measured directly with a transducer, an incomplete or erroneous

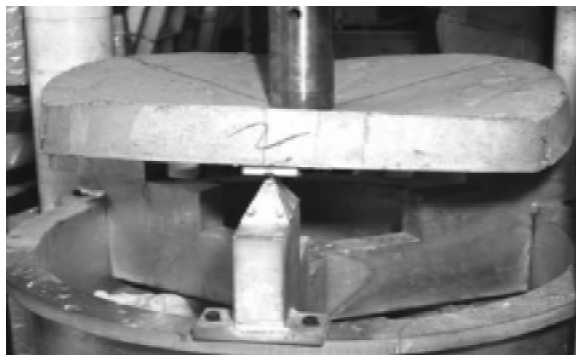

FIG. 1 Photograph of a Suggested Support Fixture

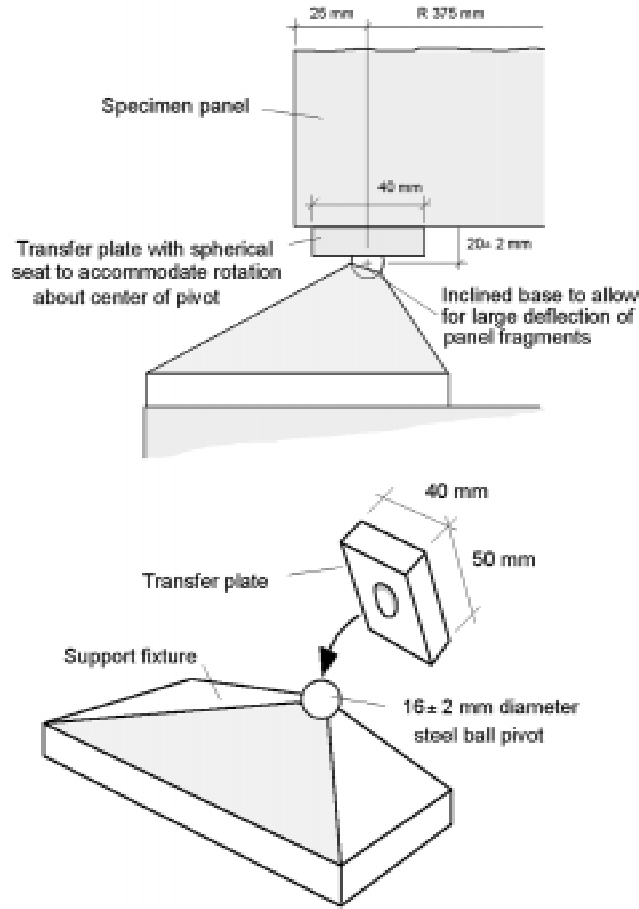

FIG. 2 Detail of Transfer Plate and Pivot Support

deflection record may occur if a crack opens at the point of measurement. It may be possible to alleviate this problem through the use of a transducer with a probe approximately 20 mm wide. The probe should not exceed this width because off-center cracks may induce exaggerated apparent deflections if they occur adjacent to a wide probe.

6.4 *Data Logging System*—Record the deflection imposed on the panel and corresponding load resistance simultaneously at a rate sufficient to record deflection in increments of no more than 0.05 mm if using a digital recording system. For a test up to a specified central deflection of 40 mm, record at least 800 data points. Deflection increments for measurements beyond this point shall be increased to 0.20 mm. If an analog X-Y plotter is used to record behavior, the scales must be chosen so that a 40 mm deflection is reached at not less than 80 % of full-scale deflection in the X direction. The peak load capacity of the specimen must be achieved at no less than 50 % of full-scale deflection in the Y direction. As a guide, the majority of specimens having standard dimensions and exhibiting normal strength fail at a load of less than 40 kN.

6.5 *Loading Piston*—The load point shall consist of a steel hemispherical piston with the dimensions shown in Fig. 3. The radius

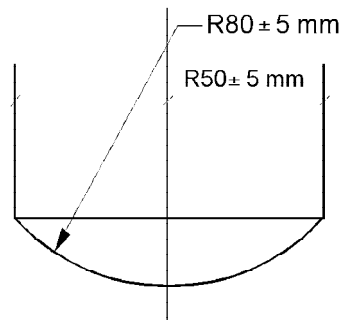

FIG. 3 Hemispherical End of Loading Piston

of the hemispherical portion of the head shall be 80 ± 5 mm, and that of the piston shaft 50 ± 5 mm.

7. Specimen Preparation and Sampling

7.1 Produce specimens with an overall diameter of 800 ± 10 mm and a thickness of 75 ± 15 mm. Panels shall not be tested if dimensions are outside of the specified limits. The standard deviation in 10 measures of thickness taken in accordance with the instructions in the procedure section must be less than 3.0 mm. Maintain these dimensions regardless of the size of aggregate or length of fiber used in the concrete or shotcrete. Make the side of the specimen perpendicular relative to the faces.

7.2 Prepare specimens in such a way as to approximate the mode of placement *in situ*. Specimens representing cast concrete shall therefore be cast, while those representing shotcrete shall be sprayed. Specimens shall be screeded to the required thickness before the concrete has hardened. Remove molds when the concrete has attained sufficient strength so that the specimen can be placed into the testing position without being damaged.

NOTE 6—Grinding or sawing of the surface to reduce an overly thick panel to the required thickness is possible, but may influence the performance of the as-cast or sprayed surface concrete.

7.3 Molds for the production of specimens shall consist of a base and side made of either non-reactive metal or coated plywood. The base and side shall be sufficiently rigid so as not to vibrate or permanently distort during casting or spraying. The interior face of the mold shall be 75 mm deep so that a screed may be run directly across the surface to produce a specimen of correct thickness.

7.4 Control the diameter of the mold through careful attention to manufacture. Maintenance of the correct thickness is subject to the skill of personnel charged with finishing the specimens. For normal setting concrete, sufficient time is normally available to screed the surface to obtain a uniform thickness. Accelerated shotcrete may, however, stiffen quickly leaving insufficient time to adequately screed the surface. In such cases, it is necessary to produce several specimens and only retain those that are uniform in thickness.

7.5 *Sampling*—Prepare at least three specimens for each batch of concrete or shotcrete tested. A sample shall consist of at least two successful tests. A successful test involves a failure that includes at least three radial cracks. Specimens occasionally fail in a beam-like mode involving a single crack across the specimen that is characterized by low energy absorption. The result of such a test shall be discarded. Only two specimens need be tested if both specimens fail by the required mode and have a standard deviation in thickness not exceeding 3.0 mm.

8. Conditioning

8.1 The purchaser shall specify the curing and moisture conditioning requirements to be used prior to testing, and the test age. If the specimens are continuously moist cured and are to be tested in a moist condition, complete testing within 15 min after removal from the moist curing conditions, or apply a curing membrane or wet burlap to control drying from the time of removal until testing is completed.

NOTE 7—Drying shrinkage strains occur in a specimen that is allowed to dry. These strains may result in micro-cracks and may reduce the flexural strength and post-crack energy absorption of the panel.

9. Procedure

9.1 Mount the test specimen in the test apparatus by placing the molded face onto the three transfer plates resting on the pivots. Center the panel with respect to both the supports and loading piston.

9.2 Measure the diameter of the panel to the nearest 2 mm at three places coincident with the intended support locations and calculate the average diameter. If the average diameter of the specimen is less than 790 mm or greater than 810 mm, discard the specimen.

9.3 Operate the testing machine so that the piston advances at a constant rate of 4.0 ± 1.0 mm/min up to a central displacement of at least 45.0 mm.

NOTE 8—The test can be extended to an end-point deflection greater than 45 mm if it is desired to examine behavior at higher levels of deformation.

NOTE 9—The central deflection at which cracking of the concrete matrix first occurs is approximately 0.50 mm for a 75 mm thick concrete specimen of normal strength and composition, exclusive of extraneous displacements. A rate of displacement equal to 4.0 mm/min therefore causes cracking of the concrete matrix in about 8 seconds. However, if a displacement-controlled testing machine is used and the surface of the specimen is rough, as is often the case with shotcrete specimens, the effective displacement rate of the center of the specimen may be less than 4.0 mm/min at the start of a test. Experience has shown that local crushing of concrete under the load point usually occurs within the first few millimeters of movement. Research has also shown that small changes in the effective rate of central displacement have only a minor influence on energy absorption for displacement rates within the range of 0.5 to 10 mm/min.⁶

9.4 Count the number of radial cracks occurring between the center and the perimeter. Any flexural crack occurring on the tensile face of the panel is counted as a full crack provided its average width exceeds 0.5 mm upon completion of the test and removal of the load.

⁶ Bernard, E. S., 2000, "The Influence of Strain Rate on Performance of Fiber-Reinforced Concrete Loaded in Flexure," *Cement, Concrete, and Aggregates*, CCAAGDP, Vol 23, No. 1, June 2001, pp. 11–18.

NOTE 10—Energy is absorbed by fiber-reinforced concrete in this test through a number of processes. Minor amounts of energy are absorbed either through elastic deformation of the specimen or as a result of friction between the underside of the specimen and the transfer plates at the three supports. The majority of energy is absorbed through the process of fiber pull-out and deformation that takes place as each crack opens in response to imposed deformation. Cracks that suffer minimal opening do not absorb significant amounts of energy and thus can be ignored. Given that the average maximum crack opening for each of the three radial cracks in this test is 10 mm at 40 mm central deflection, a crack of less than 0.5 mm width is regarded as insignificant. Laboratory experience has also demonstrated that small cracks appear to have little effect on total energy absorption.

9.5 Remove the failed specimen fragments from the test apparatus, and measure the thickness at three points along each of the cracked surfaces and at the center so that the resulting 10 values provide a representative estimate of the average thickness of the specimen. Measure the thickness to the nearest 1 mm and calculate the average thickness to the nearest 1 mm. If the average thickness is less than 60 mm or greater than 90 mm, discard the specimen. Calculate the standard deviation in thickness. If the standard deviation in thickness exceeds 3.0 mm, discard the specimen.

10. Calculation

10.1 Adjust the load-deflection record by subtracting extraneous deformations associated with compliance of the load train and crushing of concrete under the load point and at the supports. If the load-deflection record was obtained using a transducer that measured the deflection of the tensile surface of the specimen relative to the transfer plates, adjustments need only be made for crushing of concrete at the transfer plates. If the deflection of the specimen was measured through the loading mechanism of the testing machine, this record includes extraneous displacements that must be deleted from the deflection record to reveal the net deflection of the specimen.

NOTE 11—The result of a test is a load-deflection record indicating resistance to load between the onset of loading and a central deflection of at least 40 mm. Depending on the method of deflection measurement used, the load-deflection record may include extraneous deformations associated with load train compliance or crushing of the concrete around the load point or supports, or both. Extraneous deformations associated with load train compliance are regarded as systematic errors. These are discounted by computing the deformation of the load train (which is proportional to the load imposed on the specimen) and subtracting this from the recorded deflection at each deflection increment. The adjusted deflection δ of the specimen at a given load P exclusive of extraneous deformations associated with load train compliance can be calculated as:

$$\delta = \delta_m - PC_{LT} \tag{1}$$

where:

δ_m = the measured deflection including extraneous deformation due to compliance of the load train, and

C_{LT} = the compliance of the load train (see Annex A1).

Extraneous deformations associated with crushing of concrete around the load point or supports are specimen-dependent. These are manifested as offsets between the measured and net deflection of the specimen in the load-deflection record. The offset is determined approximately by linear extrapolation of the portion of the load-deflection curve occurring prior to the first peak to the horizontal (deflection) axis as shown in Fig. 4. Once the offset between the nominal and true origin for the deflection record has been determined, the load-deflection curve can be further adjusted by translation to the corrected origin. Because the magnitude of the offset may not become apparent until a test is completed, it is usually necessary to continue a test up to a central deflection that exceeds the specified central deflection by several millimetres.

10.2 Using a load-net deflection curve that has been adjusted so it is free of extraneous deformations, calculate the energy absorption between the onset of loading and the specified central deflection. Determine energy absorption as the area under the load-net deflection curve between the origin and the specified central deflection, as shown in Fig. 5. Toughness in this test is ordinarily defined at central deflections of 5, 10, 20, or 40 mm.

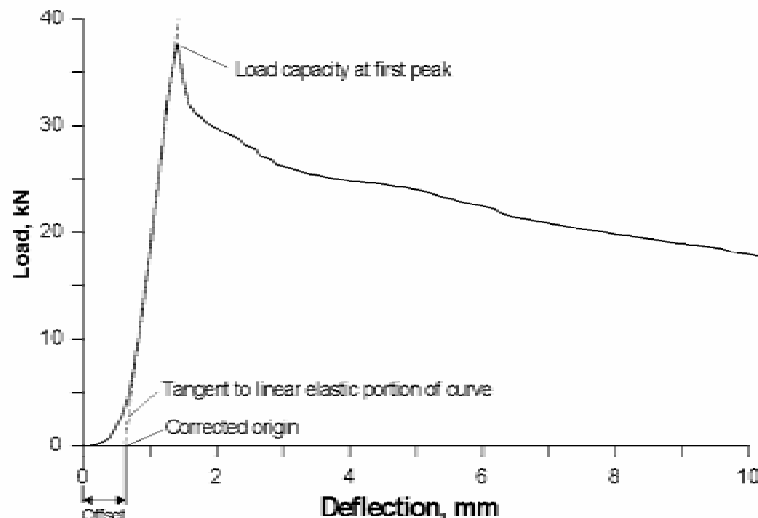

FIG. 4 . Estimation of True Origin of the Load-Deflection Curve

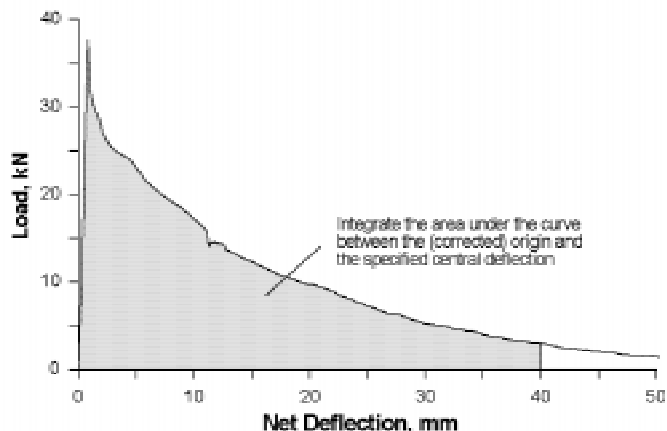

FIG. 5 Integration of Area Under Load-Net Deflection Curve to Obtain Energy Absorption

NOTE 12—If the load and net deflection are measured in units of Newtons (N) and meters (m), or kiloNewtons (kN) and millimeters (mm), the resulting measure of energy will be in units of Joules (J).

10.3 If the average thickness of the specimen is between 60 and 90 mm, and the average diameter of the specimen is between 790 and 810 mm, correct

10.3 Correct the energy absorption using the following equation:

$$W = W' \left(\frac{t_0}{t} \right)^\beta \left(\frac{d_0}{d} \right) \quad \text{where } \beta = 2.0 - (\delta - 0.5) / 80 \quad (2)$$

where:

W = the corrected energy absorption,

W' = the measured energy absorption,

t = the average thickness, mm,

t_0 = the nominal thickness of 75 mm,

d = the average diameter, mm,

d_0 = the nominal diameter of 800 mm, and

δ = the specified central deflection at which the capacity to absorb energy is measured, mm.

In Eq 2, the number 0.5 is an estimate of the elastic deflection of the specimen that occurs prior to cracking. If the average dimensions of the specimen lie outside the bounds listed above, discard the specimen and results.

11. Report

11.1 Report the following information:

11.1.1 Type of specimen (cast or sprayed) and specimen identification numbers or symbols,

11.1.2 Type of fiber observed on the cracked surfaces, and dosage rate, if known,

11.1.3 Average thickness of the specimen to the nearest 1 mm, and the standard deviation in thickness to the nearest 0.1 mm,

11.1.4 Average diameter of the specimen to the nearest 5 mm,

11.1.5 The number of radial cracks that occurred in the specimen,

11.1.6 The uncorrected and corrected values of energy absorption between the onset of loading and the specified central deflection, rounded to the nearest Joule. ~~This energy absorption value shall be corrected according to the instructions in the calculation section if the average thickness of the specimen deviates from 75 mm by more than 2 mm, Joule.~~

11.1.7 Age of specimen at test,

11.1.8 Curing history and moisture condition of specimen at test, and

11.1.9 Any defects in specimen prior to test, and abnormalities in specimen behavior during test.

12. Precision and Bias

12.1 *Precision*—Data to establish the precision of this test method in accordance with Practice C 670 have not been determined. Studies of repeatability in energy absorption up to 40 mm central displacement observed within one laboratory indicate single-operator values of the one-sigma within-batch limit (1s %) of 6%. Therefore, results from two properly conducted tests by the same operator on specimens made from the same batch of concrete are not expected to differ from each other by more than 17 %.

12.2 *Bias*—There is no bias in this test method because the energy absorption of a centrally loaded round panel can only be measured by this method.

13. Keywords

13.1 energy absorption; fiber-reinforced concrete; flexure; post-crack behavior; toughness

ANNEX

(Mandatory Information)

A1. DETERMINATION OF LOAD-TRAIN COMPLIANCE

A1.1 The compliance of the load train is the difference between the apparent compliance of the specimen when deformation of the load train is included and the true compliance of the specimen.

$$C_{LT} = C_{app} - C_{spec} \quad (A1.1)$$

where:

C_{LT} = the compliance of the load train,

C_{app} = the apparent compliance of the specimen inclusive of load train deformation,

C_{spec} = the true compliance of the specimen.

Compliance shall be measured in units of mm/kN. The term C_{spec} can be determined by dividing the load, P , to cause a given central deflection into the corresponding deflection, Δ_{spec} , measured so as to exclude deformations of the load train and corrected for crushing of concrete. Hence,

$$C_{spec} = \Delta_{spec} / P \quad (A1.2)$$

The term C_{app} is determined in a similar manner, but the central deflection, Δ_{app} , arising from the load, P , shall include the deformation of the load train.

The use of a large number of data points to determine the compliances C_{app} and C_{spec} is more accurate than the use of a single pair of points. Hence, the inverse of the slope of a line fitted through the straight portion of the load-deflection record prior to cracking is the apparent compliance of the specimen and load train, C_{app} . The inverse of the slope of a line fitted through the straight portion of the load-deflection record obtained by measurement of the deflection of the specimen relative to the support points prior to cracking is the compliance of the specimen, C_{spec} .

A1.2 The deflection of a specimen exclusive of load-train deformation is measured by applying displacement transducers directly to the surface of the specimen during a test so that the deflection of the center of the specimen is measured relative to the supported portions of the specimen. Since local crushing of the surface of the specimen is likely to occur under the load point, it is usually necessary to measure deflection at the center on the tensile face of the specimen relative to the pivot supports by means of a yoke (see Figs. A1.1 and A1.2, and Section 6). The yoke shall be loosely supported at the pivot supported to allow for a slight movement of these during deformation of the specimen. A small extraneous deformation can arise through crushing of concrete at the transfer plates, but this is corrected through attention to the off-set in the load-deflection record shown in Fig. A1.3. A plan view of a suggested test configuration for the measurement of load train compliance is shown in Fig. A1.4.

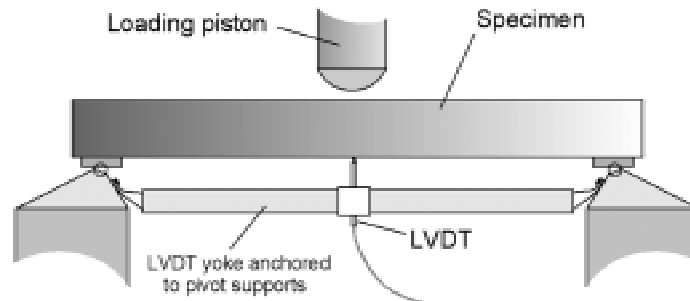

FIG. A1.1 Suggested Method of Deflection Measurement to Exclude Load-Train Deformations and Crushing of Concrete at the Point of Loading Using a Linear Variable Deflection Transducer (LVDT)

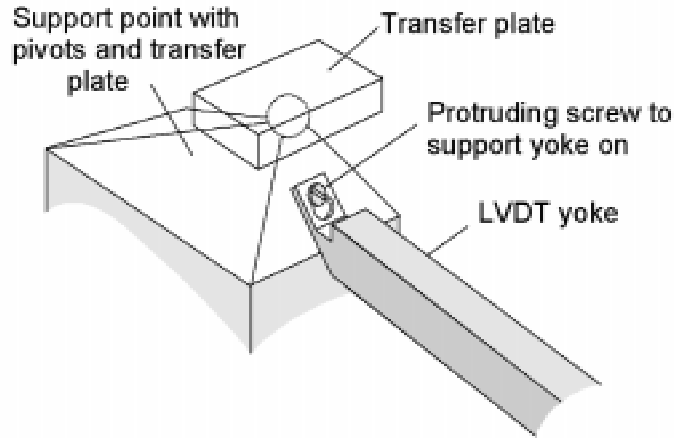

FIG. A1.2 Suggested Method of Connecting LVDT Yoke to Transfer Plates

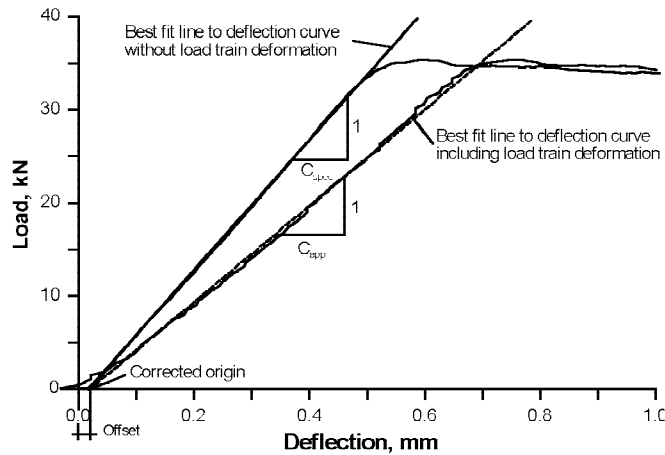

FIG. A1.3 Deflection Record for a Specimen Inclusive and Exclusive of Load Train Deformations

A1.3 The deflection of the specimen inclusive of extraneous deformations is measured by recording the displacement of the actuator relative to its immediate supports during a test. These data are normally measured using a transducer located within the test machine. The displacement of the actuator relative to its immediate supports includes the deformation of the testing machine, load cell, and load transferring fixtures, plus that of the specimen and crushing of concrete at the point of loading. Deformation associated with crushing of concrete around the load point must not be included in the assessment of load train compliance, hence only the portion of the displacement record that displays essentially linear behavior shall be used. A plot of the deflection both inclusive and exclusive of extraneous deformations is shown in Fig. A1.3. The deflection at a given load inclusive of extraneous deformations is always greater than the net deflection of the specimen (hence the magnitude of the compliance will be greater).

A1.4 Determination of the load train compliance using measurements of true and apparent specimen deflection is most reliably undertaken using data from that part of the load-deflection history for a specimen obtained prior to cracking of the concrete matrix.

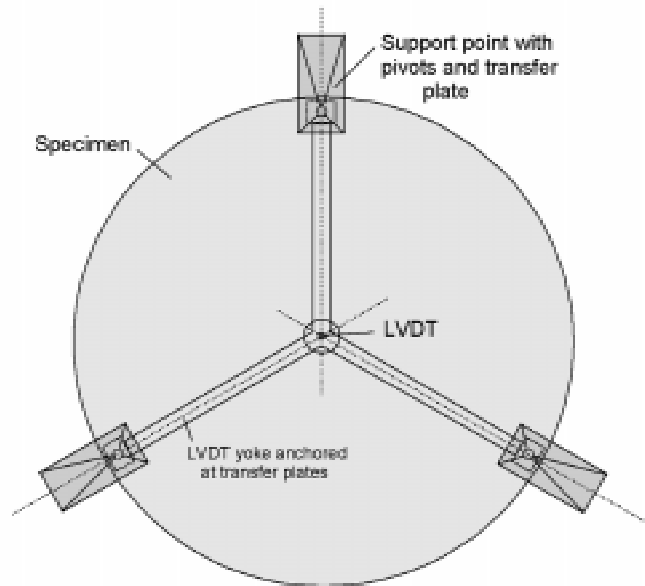

FIG. A1.4 Plan View of Suggested Method of Deflection Measurement

SUMMARY OF CHANGES

Subcommittee C09.42 has identified the location of selected changes to this standard since the last issue (C 1550 – 03) that may impact the use of this standard.

- (1) Clarified the use of the geometric correction factor and reporting requirements.
- (2) Added Note 6 to 7.2.

ASTM International takes no position respecting the validity of any patent rights asserted in connection with any item mentioned in this standard. Users of this standard are expressly advised that determination of the validity of any such patent rights, and the risk of infringement of such rights, are entirely their own responsibility.

This standard is subject to revision at any time by the responsible technical committee and must be reviewed every five years and if not revised, either reapproved or withdrawn. Your comments are invited either for revision of this standard or for additional standards and should be addressed to ASTM International Headquarters. Your comments will receive careful consideration at a meeting of the responsible technical committee, which you may attend. If you feel that your comments have not received a fair hearing you should make your views known to the ASTM Committee on Standards, at the address shown below.

This standard is copyrighted by ASTM International, 100 Barr Harbor Drive, PO Box C700, West Conshohocken, PA 19428-2959, United States. Individual reprints (single or multiple copies) of this standard may be obtained by contacting ASTM at the above address or at 610-832-9585 (phone), 610-832-9555 (fax), or service@astm.org (e-mail); or through the ASTM website (www.astm.org).