



Standard Test Method for Length Change of Hardened Hydraulic-Cement Mortar and Concrete¹

This standard is issued under the fixed designation C 157/C 157M; the number immediately following the designation indicates the year of original adoption or, in the case of revision, the year of last revision. A number in parentheses indicates the year of last reapproval. A superscript epsilon (ϵ) indicates an editorial change since the last revision or reapproval.

This standard has been approved for use by agencies of the Department of Defense.

1. Scope

1.1 This test method covers the determination of the length changes that are produced by causes other than externally applied forces and temperature changes in hardened hydraulic-cement mortar and concrete specimens made in the laboratory and exposed to controlled conditions of temperature and moisture.

1.2 The values stated in either inch-pound or SI units are to be regarded separately as standard. An exception is with regard to sieve sizes and nominal size of aggregate, in which the SI values are the standard as stated in Specification E 11. Within the text, the SI units are shown in brackets. The values stated in each system are not exact equivalents; therefore, each system must be used independently of the other, without combining values in any way.

1.3 *This standard does not purport to address all of the safety concerns, if any, associated with its use. It is the responsibility of the user of this standard to establish appropriate safety and health practices and determine the applicability of regulatory limitations prior to use.*

2. Referenced Documents

2.1 ASTM Standards:

- C 125 Terminology Relating to Concrete and Concrete Aggregates²
- C 143/C 143M Test Method for Slump of Hydraulic Cement Concrete²
- C 172 Practice for Sampling Freshly Mixed Concrete²
- C 192/C 192M Practice for Making and Curing Concrete Test Specimens in the Laboratory²
- C 305 Practice for Mechanical Mixing of Hydraulic Cement Pastes and Mortars of Plastic Consistency³
- C 490 Practice for Use of Apparatus for the Determination

of Length Change of Hardened Cement Paste, Mortar, and Concrete^{3,2}

- C 511 Specification for Moist Cabinets, Moist Rooms, and Water Storage Tanks Used in the Testing of Hydraulic Cements and Concretes^{3,2}
- C 596 Test Method for Drying Shrinkage of Mortar Containing Hydraulic Cement³
- C 1437 Test Method for Determining Flow of Hydraulic Cement Mortar³
- E 11 Specification for Wire Cloth and Sieves for Testing Purposes⁴
- E 337 Test Method for Measuring Humidity with a Psychrometer (the Measurement of Wet- and Dry-Bulb Temperatures)⁵

3. Terminology

3.1 *Definitions*—The terms used in this test method are defined in Terminology C 125.

3.2 *Definitions of Terms Specific to This Standard:*

3.2.1 *length change, n*—an increase or decrease in the length of a test specimen that has been caused to change by any factor other than externally applied forces and temperature changes.

4. Significance and Use

4.1 Measurement of length change permits assessment of the potential for volumetric expansion or contraction of mortar or concrete due to various causes other than applied force or temperature change. This test method is particularly useful for comparative evaluation of this potential in different hydraulic-cement mortar or concrete mixtures.

4.2 This test method provides useful information for experimental purposes or for products that require testing under nonstandard mixing, placing, handling, or curing conditions, such as high product workability or different demolding times. Standard conditions are described in 5.4.1.

4.3 If conditions for mixing, curing, sampling, and storage other than specified in this test method are required, they shall

¹ This test method is under the jurisdiction of ASTM Committee C09 on Concrete and Concrete Aggregates and is the direct responsibility of Subcommittee C09.68 on Methods of Testing for Volume Changes of Concrete and Concrete Aggregates.

Current edition approved June 10, 2003. Published September 2003. Originally approved in 1940. Last previous edition approved in 1999 as C 157/C 157M – 99.

² *Annual Book of ASTM Standards*, Vol 04.02.

³ *Annual Book of ASTM Standards*, Vol 04.01.

⁴ *Annual Book of ASTM Standards*, Vol 14.02.

⁵ *Annual Book of ASTM Standards*, Vol 11.03.

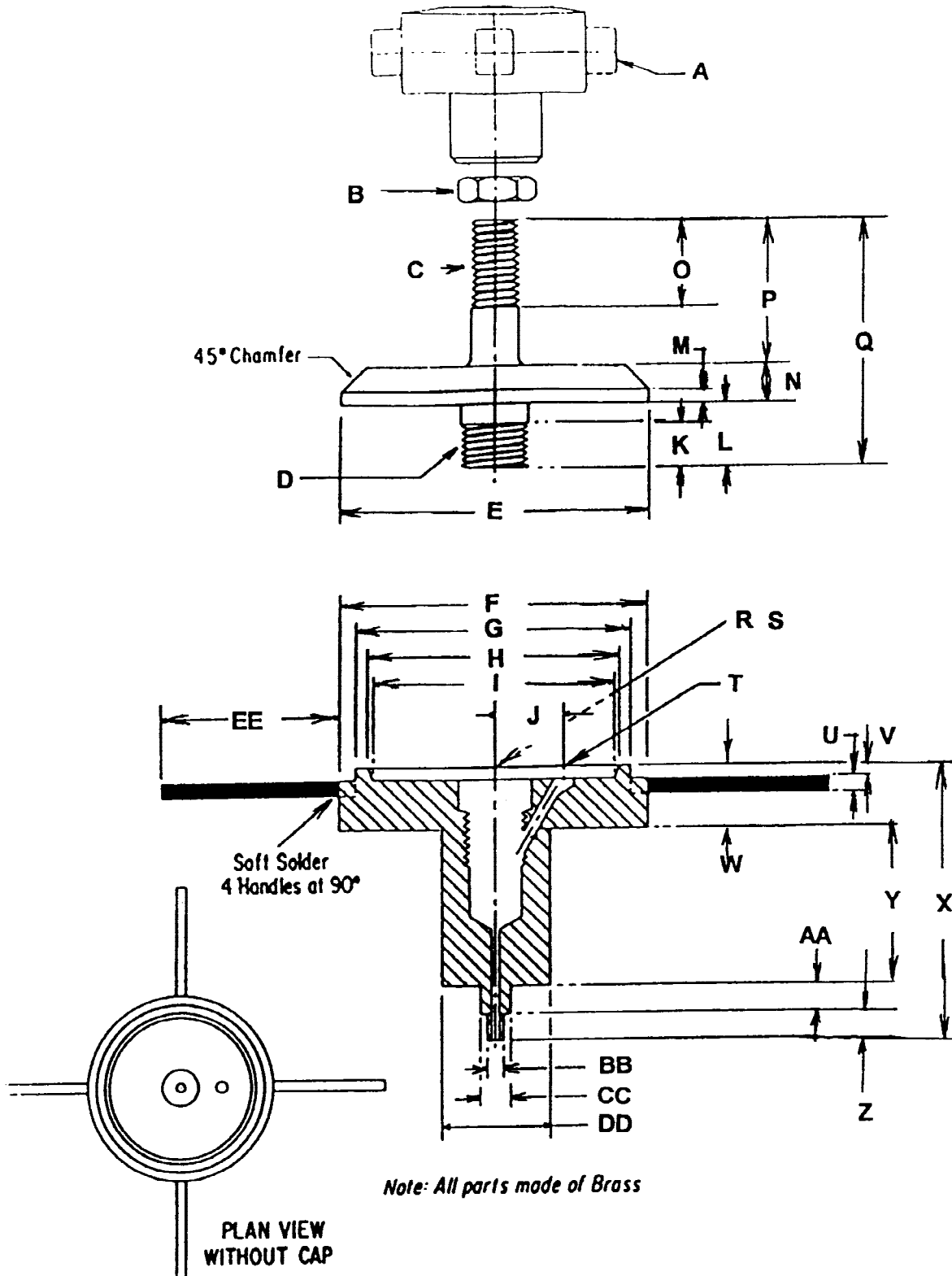

FIG. 1 Atmometer

be reported but are not to be considered as standard conditions of this test method. Nonstandard conditions and the reasons for

departure from standard conditions shall be reported clearly and prominently with comparator values.

5. Apparatus

5.1 *Molds and Length Comparator*—The molds for casting test specimens and the length comparator for measuring length change shall conform to the requirements of Practice C 490.

5.2 *Tamper*—The tamper shall be made of a nonabsorptive, nonabrasive material such as medium-hard rubber or seasoned oak wood rendered nonabsorptive by immersion for 15 min in paraffin at approximately 392°F [200°C], and shall have a cross section of ½ by 1.0 in. [13 by 25 mm] and a convenient length of about 6 in. [150 mm]. The tamping face of the tamper shall be flat and at right angles to the length of the tamper.

5.3 *Tamping Rod*—The tamping rod shall be a straight steel rod ⅜ in. [10 mm] in diameter and not less than 10 in. [250 mm] in length, having at least the tamping end rounded to a hemispherical tip of the same diameter.

5.4 *Drying Room and Controls*—A drying room with suitable racks shall be provided for storing specimens in air. The racks shall be designed for free circulation of air around specimens, except for necessary supports, and shall be so situated with respect to the nearest wall or other obstruction that air circulation is not restricted in the intervening space. The supports shall be horizontal and shall consist of two nonabsorptive members not deeper than 1 in. [25 mm] and having a bearing area of not more than ¼ in. [6 mm] in width. Conditioned air shall be circulated into and out of the room in a uniform manner so that the specified rate of evaporation is attained adjacent to all specimens.

5.4.1 The air in the room shall be maintained at a temperature of 73 ± 3°F [23 ± 2°C] and a relative humidity of 50 ± 4 %. The air movement past all specimens shall be such that the rate of evaporation is 77 ± 30-mL/24 h from an atmometer or 13 ± 5-mL/24 h from a 400-mL Griffin low-form beaker filled to ¾ in. [20 mm] from the top. The temperature and relative humidity of the air in the room shall be measured with either a sling or Assmann psychrometer at least twice each working day. The psychrometer shall comply with Test Method E 337, except that thermometers having an over-all length of 10 in. [250 mm] and marked in subdivisions of 0.5°F [0.25°C] are permitted. The room shall be equipped with a means of measuring and recording wet- and dry-bulb temperatures continuously. Correction factors as indicated by the sling or Assmann psychrometer shall be applied to the recorded data. The rate of evaporation within the room shall be determined daily by the use of the atmometer or by the loss of mass of water from a 400-mL Griffin low-form beaker filled initially to ¾ in. [20 mm] from the top.

5.5 *Atmometer*—The atmometer shall be constructed as shown in Fig. 1.

5.5.1 *Mounting*—Fig. 2 shows a suggested arrangement for operating the atmometer. Punch a central hole ½ in. [13 mm] in diameter in a filter paper, place it on the atmometer, and secure it in place while dry, by turning the torque handle only, until it just starts to slip. Mount the atmometer on a stand with the filter paper in a horizontal position. Mount a 100-mL glass graduate so that the 100-mL mark is from 1 to 3 in. [25 to 75

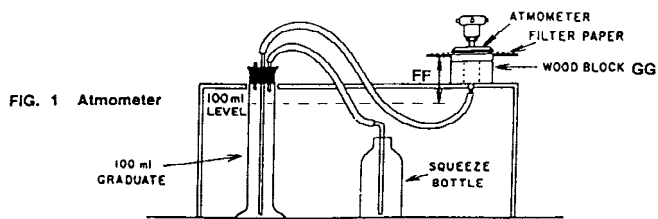

FIG. 2 Atmometer Assembly

mm] below the level of the filter paper. Stopper the graduate so that entrance is provided for two short glass tubes not extending to the water level and one long tube extending to the bottom of the graduate. Connect the glass tubing leading from the bottom of the graduate to the inlet of the atmometer by means of clear plastic tubing.

5.5.2 *Operation*—Use clear plastic tubing to connect a squeeze bottle containing distilled or deionized water to one of the short glass tubes into the graduate. Force water into the graduate until it is about half full and then close the remaining glass tube into the graduate. Continue to force water through the graduate into the atmometer until the filter paper is saturated and there are no air bubbles in the system. Open the glass tube into the graduate and release pressure on the squeeze bottle gradually to avoid trapping air in the tube leading to the atmometer. Adjust the level of water in the graduate to approximately the 100-mL mark. If the atmometer is to be used under variable temperature conditions, disconnect the squeeze bottle after filling the graduate to avoid the possibility of additional water being forced into the graduate. Permit evaporation of water from the filter paper for 1 h before recording the time and initial reading of the graduate. It is not permitted to omit the waiting period during subsequent use of the atmometer provided the filter paper does not become dry. Change the filter paper whenever it shows signs of contamination but not less frequently than once every two weeks.

5.6 *Filter Paper*—The filter paper to be used with the atmometer shall be white with a smooth surface texture. It shall be 6 in. [152 mm] in diameter and 0.050 ± 0.003 in. [1.27 ± 0.08 mm] thick and shall have a cotton fiber content of not less than 75 weight %. The density shall be between 0.400 and 0.425 g/cm³. The Mullen bursting strength shall not be less than 50 psi [345 kPa].

NOTE 1—E and D filter paper No. 625⁶ has been found suitable.

5.7 *Apparatus for Demolding Specimens*—It is useful to construct an apparatus for demolding specimens molded in double molds as detailed in Fig. 3 or to a different design that serves the same purpose. When this device is to be used, the center side plate of the double mold must be appropriately drilled and tapped to receive the 8-32 by ⅝ in. [4.5-0.74 IMC by 16 mm] machine screw of the demolding thumbscrew. Fig.

⁶ Manufactured by and available for Eaton-Dikeman Co., Mt. Holly Springs, PA 17065.

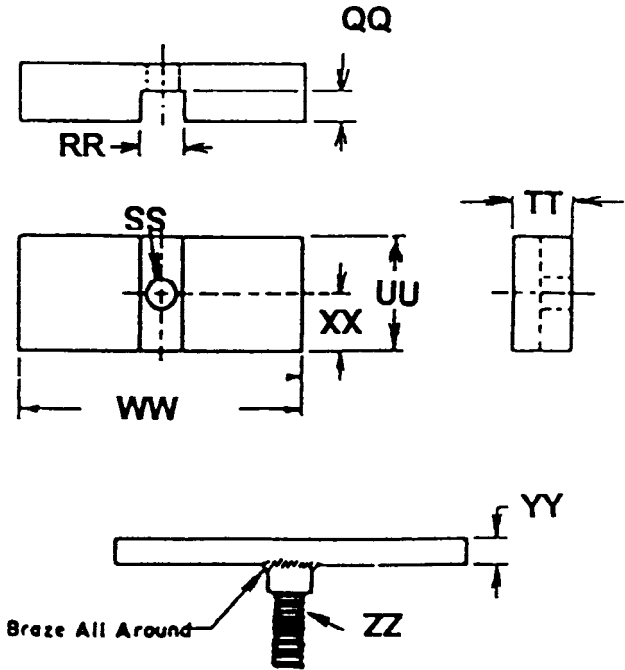

Instructions for Use—Remove the end and the outer side plates leaving the base, center side plate, and gage stud holders in place. Engage the machine screw in the drilled and tapped end of the center side plate. Turn the thumbscrew to loosen the bars.

FIG. 3 Device for Detaching 1-in. [25-mm] Square by 11¼-in. [285-mm] Bars from Center Side Plate of Double Molds

4 shows the details of an apparatus for demolding specimens molded in single molds.

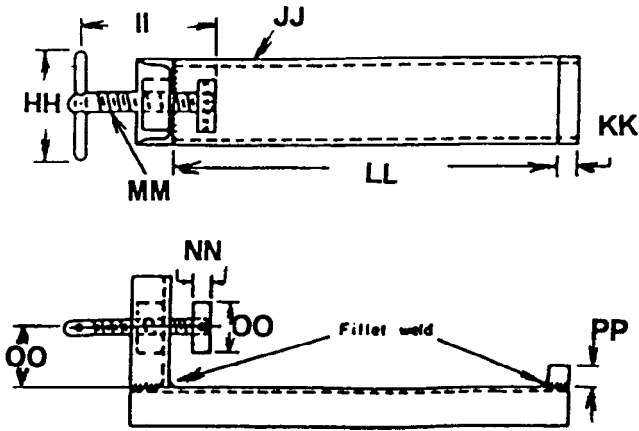

NOTE—Dimensions shown are appropriate for one design of mold for 3-in. [75-mm] square specimens. Change dimensions as required for other molds.

FIG. 4 Device for Demolding Specimens from Single Molds

ASTM C 157 FIGURES

Figure	Dimensions	SI Units	Inch-Pound Units
A	Adjustable torque handle	1.4–1.7 Nm	Adjustable torque handle 12–15 in.lb
B	Jam nut	10–15 IMC	Jam nut ¾-in.–16 NC
C	10-mm diameter 1.5 IMC Thd.	12-mm diameter 1.5 IMC Thd.	¾-in. dia–16 NC Thd. ½-in. dia–20 NC Thd.
D	64-mm diameter	64-mm diameter	2.50-in. diameter
E	64-mm diameter	64-mm diameter	2.50-in. diameter
F	57-mm diameter	57-mm diameter	2.25-in. diameter
G	52-mm diameter	52-mm diameter	2.06-in. diameter
H	51-mm diameter	51-mm diameter	2.00-in. diameter
I	14 mm	14 mm	0.56 in.
J	8 mm	8 mm	0.31 in.
K	13 mm	13 mm	0.50 in.
L	3 mm	3 mm	0.125 in.
M	8 mm	8 mm	0.31 in.
N	19 mm	19 mm	0.75 in.
O	32 mm	32 mm	1.25 in.
P	53 mm	53 mm	2.06 in.
Q	1.5-mm drill through 11.5-mm C'	1.5-mm drill through 11.5-mm C'	⅛-in. drill through 29/64-in. C' drill
R	32-mm deep tap 12-mm 1.5-mm IMF Thd	32-mm deep tap 12-mm 1.5-mm IMF Thd	1¼-in. deep tap ½-in.–20 Thd
S	19 mm deep 16 mm C' bore 6 mm deep	19 mm deep 16 mm C' bore 6 mm deep	¾-in. deep ⅝-in. C' bore ¼ in. deep
T	5-mm drill 3-mm deep C' drill at 60° as shown through to center tapped hole	5-mm drill 3-mm deep C' drill at 60° as shown through to center tapped hole	⅜-in. drill ⅜-in. deep C' drill at 60° as shown through to center tapped hole
U	3 mm	3 mm	0.12 in. diameter
V	2 mm	2 mm	0.09 in.
W	10 mm	10 mm	0.40 in.
X	60 mm	60 mm	2.36 in.
Y	35 mm	35 mm	1.37 in.
Z	6 mm	6 mm	0.25 in.
AA	6 mm	6 mm	0.25 in.
BB	4 mm	4 mm	0.15 in.
CC	6 mm	6 mm	0.25 in.
DD	23 mm	23 mm	0.87 in.
EE	38 mm	38 mm	1.50 in.
FF	25 to 75 mm	25 to 75 mm	1 to 3 in.
GG	35 mm high	35 mm high	1.37 in. high
HH	100 mm	100 mm	4 in.
II	130 mm	130 mm	5 in.
JJ	8 cm–6.1 kg/m channel	8 cm–6.1 kg/m channel	3 in.–4.1 lb/ft channel
KK	20 mm	20 mm	¾ in.
LL	330 mm	330 mm	13 in.
MM	14–2.0 IMC Thd.	14–2.0 IMC Thd.	½ in.–12 Thd.
NN	20 mm	20 mm	¾ in.
OO	50 mm	50 mm	2 in.
PP	20 mm	20 mm	¾ in.
QQ	60 mm	60 mm	¼ in.
RR	10 mm	10 mm	¾ in.
SS	Drill Cl. hole for 4.5–0.75 IMC machine screw	Drill Cl. hole for 4.5–0.75 IMC machine screw	Drill Cl. hole for 8–32 in. machine screw
TT	13 mm	13 mm	½ in.
UU	25 mm	25 mm	1 in.
VV	30 mm	30 mm	1–3/16 in.
WW	60 mm	60 mm	2–3/8 in.
XX	12.5 mm	12.5 mm	½ in.
YY	6-mm diameter steel rod	6-mm diameter steel rod	¼-in. diameter steel rod
ZZ	4.5–0.75 IMC × 16-mm machine screw	4.5–0.75 IMC × 16-mm machine screw	8–32 × ⅝-in. machine screw

6. Sampling

6.1 Take samples according to the applicable provisions of Practice C 192/C 192M from batches of hydraulic-cement mortar or concrete made in the laboratory (Note 2).

NOTE 2—When collecting samples in nonstandard conditions, such as field concrete, it is suggested that Practice C 172 be followed. Field cast specimens can show up to twice as much drying shrinkage as laboratory cast specimens from the same materials and proportions.

7. Test Specimens

7.1 *Mortar*—The test specimen for mortar shall be a prism of 1-in. [25-mm] square cross-section and approximately 11¼ in. [285 mm] in length. Three specimens shall be prepared for each test condition.

7.2 *Concrete*—The test specimen for concrete, in which all of the aggregate passes a 2-in. [50-mm] sieve, shall be a prism of 4-in. [100-mm] square cross-section and approximately 11¼ in. [285 mm] long. However, a prism of 3-in. [75-mm] square cross-section shall be used if all of the aggregate passes a 1-in. sieve [25.0-mm]. Three specimens shall be prepared for each test condition. Since length change is capable of being influenced by the size of the specimen, specimens to be compared shall have the same dimensions, and any specification limit based upon this method shall be applied to a specified size of specimen.

8. Procedure for Mixing Mortars and Concrete

8.1 If the mortar or concrete to be tested is made in accordance with requirements other than those given in one of the following paragraphs, samples shall be taken and specimens molded as described in the sections on sampling and on molding specimens.

8.2 Bring all materials to a temperature between 65 and 75°F [18 and 24°C] before using to make mortar or concrete. Proportion solid materials by mass (that is, not by volume). It is permissible to batch water and liquid admixtures either by mass or by volume. For calculation of batch quantities, assume aggregates to be saturated and surface-dry; if they are not in this condition at the time of use, apply appropriate corrections, as necessary, to batch quantities to compensate for absorption or free moisture.

8.3 *Mortar*—Mix mortar in a mechanical mixer as described in Practice C 305. The clearances between paddle and bowl specified in Practice C 305 are suitable only for mortars made with fine aggregates that are finer than the 2.36 mm (No. 8) sieve. Mortars made with aggregates containing particles coarser than this sieve require special clearances or a different type of paddle to permit the mixer to operate freely and to avoid damage to the paddle and bowl. The sequence of mixing shall be in accordance with the applicable provisions of Practice C 305. Determine the flow of the mortar in accordance with the applicable provisions of Test Method C 1437, and use sufficient mixing water to produce a flow of $110 \pm 5\%$.

8.4 *Concrete*—Mix concrete in a suitable laboratory mixer in accordance with the applicable provisions of Practice C 192/C 192M. Determine the slump of the concrete using Test Method C 143/C 143M, and use sufficient mixing water to produce a slump of $3.5 \pm \frac{1}{2}$ in. [90 \pm 15 mm].

9. Procedure for Molding Specimens

9.1 *Mortar Specimens*—Place the mortar in the mold in two approximately equal layers. Compact each layer with the tamper. Work the mortar into the corners, around the gage studs, and along the surfaces of the mold with the tamper until a homogeneous specimen is obtained. After the top layer has been compacted, strike off the mortar flush with the top of the mold, and smooth the surface with a few strokes of a trowel. Immediately after completion of molding, loosen the device by holding the gage studs in position at each end of the mold in order to prevent any restraint of the gage studs during initial shrinkage of the specimen.

9.2 *Concrete Specimens*—Place the concrete in the mold in two approximately equal layers in accordance with the general instructions for placing concrete in specimens given in Practice C 192/C 192M. Consolidate each layer by rodding, except use external vibration if the slump is less than 3 in. [75 mm] in accordance with the instructions for consolidation of flexure test specimens given in Practice C 192/C 192M. The same method of consolidation is to be used for all specimens to be compared. In addition, as the top layer is being placed, work the concrete thoroughly around each gage stud with the fingers. The top layer shall slightly overfill the mold. After consolidation is complete, strike off the excess material with a straight-edge. Immediately after completion of molding, loosen the device by holding the gage studs in position at each end of the mold in order to prevent any restraint of the gage studs before the test specimens are demolded.

10. Procedure for Curing of Specimens

10.1 Cure the test specimens in the molds in a moist cabinet or room in accordance with Specification C 511. Protect specimens from dripping water.

10.2 Remove specimens from the molds at an age of $23\frac{1}{2} \pm \frac{1}{2}$ h after the addition of water to the cement during the mixing operation. In order to avoid damage during removal from the molds, it is not permitted, especially in the case of certain slow-hardening cements, to allow specimens to remain in the molds for more than 24 h. When this is found necessary the moist curing schedule shall be extended, but all specimens that are to be directly compared with each other shall be subjected to the same conditions of moist-curing and shall have their initial comparator reading made within $\pm \frac{1}{2}$ h of the same age. Use the demolding device to remove specimens without striking or jarring and with particular care not to exert pressure directly against the gage studs. The gage stud holder shall remain attached to the stud during this operation. Marks placed on the specimens for identification or positioning are only to be made by graphite applied either by a soft pencil or as a liquid that deposits essentially graphite without binder or made with waterproof indelible ink. Upon removal of the specimens from the molds, place them in lime-saturated water maintained at $73 \pm 1^\circ\text{F}$ [$23 \pm 0.5^\circ\text{C}$] for a minimum of 15 min in the case of 1-in. [25-mm] square cross-section specimens, and for a minimum of 30 min in the case of 3-in. [75-mm] or 4-in. [100-mm] square cross section specimens before being measured for length. This is to minimize variation in length due to variation in temperature. At an age of $24 \pm \frac{1}{2}$ h after the

addition of water to the cement during the mixing operation, remove the specimens from water storage one at a time, wipe with a damp cloth, and immediately take the initial comparator reading.

10.3 After the initial comparator reading, store the specimens in lime-saturated water at $73 \pm 3^\circ\text{F}$ [$23 \pm 2^\circ\text{C}$] until they have reached an age of 28 days, including the period in the molds. At the end of the curing period, take a second comparator reading after the specimens have been brought to a more closely controlled temperature as was done prior to the earlier reading and in the manner described above.

NOTE 3—To determine the drying shrinkage of concrete subjected to elevated temperature curing in the laboratory, a modification of the previous method is necessary. Where concrete is cured with elevated (non-autoclave) temperatures, the curing cycle for this test method shall be that to be used for the project structural members. The elevated temperature curing cycle consists of pre-steam, steam cure, and post-steam periods. To avoid measuring thermal volume change, after the molds are stripped, cool drying-shrinkage specimens at laboratory temperature until they reach equilibrium (approximately 6 h for 4 by 4 by 11-in. [100 by 100 by 280-mm] bars). Then place them in lime-saturated water prior to the initial reading (see 10.2).

11. Procedure for Storage of Specimens

11.1 After measurement at the end of the curing period, store the specimens as described in either of the following:

11.1.1 *Water Storage*—Immerse the specimens in lime-saturated water storage in accordance with Specification C 511. Take comparator readings of each specimen when it has reached an age, including the curing period of 8, 16, 32, and 64 weeks. Make these readings immediately after the specimens have been subjected to storage in water at $73 \pm 1^\circ\text{F}$ [$23 \pm 0.5^\circ\text{C}$] for at least 15 min in the case of 1-in. [25-mm] specimens or 30 min in the case of 3-in. [75-mm] or 4-in. [100-mm] specimens.

11.1.2 *Air Storage*—Store the specimens in the drying room, so that the specimens have a clearance of at least 1 in. or 25 mm on all sides. Take comparator readings of each specimen after periods of air storage after curing of 4, 7, 14, and 28 days, and after 8, 16, 32, and 64 weeks. Preferably, take these readings in a room maintained at a relative humidity of $50 \pm 4\%$ while the specimens are at a temperature of $73 \pm 3^\circ\text{F}$ [$23 \pm 2^\circ\text{C}$].

12. Procedure for Calculating Length Change

12.1 *Comparator Reading*—Read the comparator dial with the test specimen in the comparator; then read the comparator dial with the reference bar in the comparator. Calculate the difference between the two readings as described in Practice C 490.

12.2 *Length Change*—Calculate the length change of any specimen at any age after the initial comparator reading as follows:

$$\Delta L_x = \frac{CRD - \text{initial } CRD}{G} \times 100 \quad (1)$$

where:

ΔL_x = length change of specimen at any age, %,

CRD = difference between the comparator reading of the specimen and the reference bar at any age, and

G = the gage length (10 in. [250 mm]) (see Note 4).

NOTE 4—In Practice C 490, the comparator dial gage specified for use with 10-in. gage length specimens shall be graduated in fractions of an inch; the comparator dial gage specified for use with 250-mm gage length specimens shall be graduated in fractions of a millimetre.

13. Report

13.1 Report the following information:

13.1.1 Identification as mortar or concrete specimens, number of specimens for each condition, and date molded,

13.1.2 Source and identification of each material employed,

13.1.3 Type, maximum size, moisture condition, and grading of the aggregate,

13.1.4 Size of specimens,

13.1.5 Mortar or concrete mixture data at time of mixing, including flow or slump and temperature of mixture,

13.1.6 Description of consolidation of concrete, specifying whether rodding or external vibration was used,

13.1.7 Conditions and periods of moist curing prior and subsequent to removal of molds, if different from those specified,

13.1.8 Description of storage condition, including temperature and humidity, either by indicating whether the water or air storage was followed or by giving the details of any procedure not conforming to either of these conditions,

13.1.9 Total elapsed time of storage and total age of specimen, or total elapsed time of curing and storage if the same condition was used for both,

13.1.10 Length change data, reported as percent increase or decrease in linear dimension to the nearest 0.001 % of the gage length based on the initial measurement made at the time of removal from the molds, and

13.1.11 Any other pertinent information.

14. Precision and Bias

14.1 *Precision:*

14.1.1 When this test method was used for the purpose of determining drying shrinkage of mortar as affected by the choice of portland cement used in making it, the precision was found to be as reported in Test Method C 596.

14.1.1.1 The following single-laboratory, multiple-operator precision applies to concrete specimens measured at 180 days.

14.1.1.2 For specimens stored in water, the standard deviation (1s) among specimens is 0.0045 %. When three replicate specimens are tested, the maximum range among them is not expected to exceed 0.0266 % in 95 % of the sets tested. When a test result represents the mean of three specimens, the 1s is 0.0026 %. The difference between two such means is not expected to exceed 0.0074 % in 95 % of such duplicate tests performed.

14.1.1.3 For specimens stored in air, the standard deviation (1s) among specimens is 0.0084 %. When three replicate specimens are tested, the maximum range among them is not expected to exceed 0.0496 % in 95 % of the sets tested. When a test result represents the mean of 3 specimens, the 1s is

0.0048 %. The difference between two such means is not expected to exceed 0.0137 % in 95 % of such duplicate tests performed.

NOTE 5—These precision values were calculated from data taken on specimens described on p. 47 of STP 205,⁷ representing 193 concrete

mixtures; two specimens made from each of three batches made on separate days, one of each two specimens stored in water, the other stored at nominal 50 % relative humidity.

14.2 *Bias*—No statement on bias is being made since there is no accepted reference material suitable for determining the bias of these procedures.

15. Keywords

15.1 length change; mortar concrete

⁷ Mather, Bryant, “The Partial Replacement of Portland Cement in Concrete,” *Cement and Concrete*, ASTM STP 205, ASTM, 1958.

ASTM International takes no position respecting the validity of any patent rights asserted in connection with any item mentioned in this standard. Users of this standard are expressly advised that determination of the validity of any such patent rights, and the risk of infringement of such rights, are entirely their own responsibility.

This standard is subject to revision at any time by the responsible technical committee and must be reviewed every five years and if not revised, either reapproved or withdrawn. Your comments are invited either for revision of this standard or for additional standards and should be addressed to ASTM International Headquarters. Your comments will receive careful consideration at a meeting of the responsible technical committee, which you may attend. If you feel that your comments have not received a fair hearing you should make your views known to the ASTM Committee on Standards, at the address shown below.

This standard is copyrighted by ASTM International, 100 Barr Harbor Drive, PO Box C700, West Conshohocken, PA 19428-2959, United States. Individual reprints (single or multiple copies) of this standard may be obtained by contacting ASTM at the above address or at 610-832-9585 (phone), 610-832-9555 (fax), or service@astm.org (e-mail); or through the ASTM website (www.astm.org).