



# Standard Test Method for Tensile Strength of Concrete Surfaces and the Bond Strength or Tensile Strength of Concrete Repair and Overlay Materials by Direct Tension (Pull-off Method)<sup>1</sup>

This standard is issued under the fixed designation C 1583; the number immediately following the designation indicates the year of original adoption or, in the case of revision, the year of last revision. A number in parentheses indicates the year of last reapproval. A superscript epsilon ( $\epsilon$ ) indicates an editorial change since the last revision or reapproval.

## 1. Scope

1.1 This test method is suitable for both field and laboratory use to determine one or more of the following:

1.1.1 The near-surface tensile strength of the substrate as an indicator of the adequacy of surface preparation before application of a repair or overlay material.

1.1.2 The bond strength of a repair or an overlay material to the substrate.

1.1.3 The tensile strength of a repair or overlay material, or an adhesive used in repairs, after the material has been applied to a surface.

1.2 The values stated in either SI units or inch-pound units are to be regarded separately as standard. The values stated in each system may not be exact equivalents; therefore, each system shall be used independently of the other. Combining values from the two systems may result in non-conformance with the standard.

1.3 *This standard does not purport to address all of the safety concerns, if any, associated with its use. It is the responsibility of the user of this standard to establish appropriate safety and health practices and determine the applicability of regulatory limitations prior to use.*

## 2. Referenced Documents

### 2.1 ASTM Standards:<sup>2</sup>

- C 125 Terminology Relating to Concrete and Aggregates
- C 881/C 881M Specification for Epoxy-Resin Base Bonding Systems for Concrete
- C 900 Test Method for Pullout Strength of Hardened Concrete

<sup>1</sup> This test method is under the jurisdiction of ASTM Committee C09 on Concrete and Concrete Aggregates and is the direct responsibility of Subcommittee C09.25 on Organic Materials for Bonding, Patching and Sealing Concrete.

Current edition approved Feb. 1, 2004. Published March 2004.

<sup>2</sup> For referenced ASTM standards, visit the ASTM website, [www.astm.org](http://www.astm.org), or contact ASTM Customer Service at [service@astm.org](mailto:service@astm.org). For *Annual Book of ASTM Standards* volume information, refer to the standard's Document Summary page on the ASTM website.

## 3. Terminology

3.1 *Definitions*—For definitions of terms used in this test method refer to Terminology C 125 and ACI 503R<sup>3</sup>.

## 4. Summary of Test Method

4.1 This test is performed on the surface of a prepared concrete base before application of a concrete repair or overlay material, or on the surface of a concrete repair or overlay material after the material has been applied to the prepared concrete surface.

4.2 The test specimen is formed by drilling a shallow core into and perpendicular to the surface of the substrate, and leaving the intact core attached to the concrete. A steel disk is bonded to the top surface of the test specimen.

4.3 A tensile load is applied to the steel disk until failure occurs. The failure load and the failure mode are recorded and the nominal tensile stress at failure is calculated.

## 5. Significance and Use

5.1 This test method determines the tensile strength of concrete near to the prepared surface, which can be used as an indicator of the adequacy of surface preparation before applying a repair or an overlay material.

5.2 When the test is performed on the surface of a repair or an overlay material, it determines the bond strength to the substrate or the tensile strength of either the overlay or substrate, whichever is weaker.

5.3 The method may also be used to evaluate the adhesive strength of bonding agents.

5.4 When the test is performed on the surface of a material applied to the substrate, the measured strength is controlled by the failure mechanism requiring the least stress. Thus it is not possible to know beforehand which strength will be measured by the test. For this reason, the failure mode has to be reported for each individual test result, and tests results are averaged only if the same failure mode occurs.

<sup>3</sup> ACI 503R-93 (Reapproved 1998), "Use of Epoxy Compounds with Concrete," American Concrete Institute (ACI), P.O. Box 9094, Farmington Hills, MI 48333.

## 6. Apparatus

6.1 *Core Drill*, for preparing test specimen.

6.2 *Core Barrel*, with diamond impregnated bits - nominally 50 mm [2.0 in.] inside diameter.

6.3 *Steel Disk*, nominally 50 mm [2.0 in.] diameter and at least 25 mm [1.0 in.] thick.

6.4 *Tensile Loading Device*, with a load-indicating system and nominal capacity of 22 k N (5,000 lbf) and capable of applying load at the specified rate. The loading device includes a tripod or bearing ring for distributing the force to the supporting surface.

6.4.1 Within the operating range, the indicated tensile force shall be within  $\pm 2\%$  of the force measured by a calibrated testing machine or load cell. Verify the tensile loading device at least once a year and after repairs and adjustments.

NOTE 1—See Test Method C 900 for suitable verification schemes.

6.4.2 A coupling device shall be used to connect the steel disk to the tensile loading device. The coupling device shall be designed to withstand the tensile load capacity without yielding, and to transmit the tensile force parallel to and in line with the axis of the cylindrical test specimen without imparting torsion or bending to the test specimen.

## 7. Materials

7.1 Epoxy adhesive material for bonding the steel disk to the test specimen. It shall be a fast-curing paste or gel meeting the requirements of Specification C 881/C 881M for Type IV, Grade 3, except that a shorter gel time is permitted.

## 8. Sampling

8.1 Three individual test results with similar failure modes shall be obtained for each test site.

8.2 The field test site shall be large enough so that all methods to be used in the full-scale repair or overlay operation, including surface preparation, are used for preparing test specimens. The test site shall be at least 1 by 1 m [3 by 3 ft]. It shall be selected to be representative of actual field conditions.

8.3 If concrete cover is less than 20 mm [ $\frac{3}{4}$  in.], do not locate test specimens directly over bars in the layer of reinforcement nearest to the surface.

NOTE 2—The location of reinforcement may be established using reinforcement locators or metal detectors. Follow the manufacturer's recommendations for proper operation of such devices.

8.4 The center-to-center distance of adjacent test specimens shall be at least two disk diameters. The distance from the center of a test specimen and a free edge of the test object shall be at least one disk diameter.

## 9. Preparation of Surface

9.1 *Preparation to Determine Tensile Strength of Substrate:*

9.1.1 Remove all surface contaminants and loose or deteriorated concrete to obtain a clean, undamaged surface.

9.1.2 Prepare the surface using the same method to be used in the full-scale repair or overlay.

9.1.3 The surface must be in the same condition regarding dryness and cleanliness as specified for the actual work.

9.2 *Preparation to Determine Bond or Tensile Strength of the Repair or Overlay Material:*

9.2.1 Prepare the surface in accordance with 9.1.

9.2.2 Apply and cure the repair or overlay material in accordance with specifications for the repair or overlay operation.

## 10. Preparation of Test Specimen

10.1 Using the coring equipment, drill a circular cut perpendicular to the surface. For tests of substrate concrete, drill to a depth of at least 10 mm [0.5 in.]. For tests of repair or overlay materials, drill to at least 10 mm [0.5 in.] below the concrete-overlay interface. The test specimen is left intact, attached to the substrate. Measure the diameter of the test specimen in two directions at right angles to each other. Record the average diameter to the nearest 0.2 mm [0.01 in.].

10.2 Remove any standing water; clean the surface of any debris from the drilling operation and allow to dry.

10.3 Attach the steel disk to the top of the test specimen using the epoxy adhesive. Ensure that the disk is centered with the test specimen and that the axis of the disk is parallel to the axis of the test specimen. Cure the epoxy adhesive following manufacturer's instructions (see Note 4). Do not allow the adhesive to run down the side of the test specimen into the annular cut; if this occurs, the specimen is not tested and another is prepared. At temperatures below 20°C [70°F], it is permitted to gently heat the steel disk to no more than 50°C [120°F] to facilitate spreading of the adhesive and to accelerate curing. The test specimen shall not be heated with a direct flame.

NOTE 3—Figs. 1 and 2 are schematics of the tests for determining tensile strength of the substrate and bond or tensile strength of the repair or overlay material, respectively. These schematics are not intended to indicate specific equipment designs.

NOTE 4—Guidance on applying and curing the epoxy adhesive may be found in ACI 503R.

## 11. Test Procedure

11.1 Attach the tensile loading device to the steel disk using the coupling device.

11.2 Apply the tensile load to the test specimen so that the force is parallel to and coincident with the axis of the specimen.

11.3 Apply the tensile load at a constant rate so that the tensile stress increases at a rate of  $35 \pm 15$  kPa/s [ $5 \pm 2$  psi/s].

11.4 Record the failure load and the failure mode. Record the failure mode as (a) in the substrate, (b) at the bond line between the substrate and the repair or overlay material, (c) in the repair or overlay material, or (d) at the bond line between the repair or overlay material and the epoxy adhesive used to bond the steel disk. If failure occurs at the bond line between the steel disk and the epoxy adhesive, discard the test result and perform another test. Refer to Fig. 3 for schematics of the different failure modes.

11.5 Report results as bond strength when failure occurs in the bond line between the substrate and the repair or overlay material. Report results as tensile strength when the failure occurs in the substrate or the repair or overlay material.

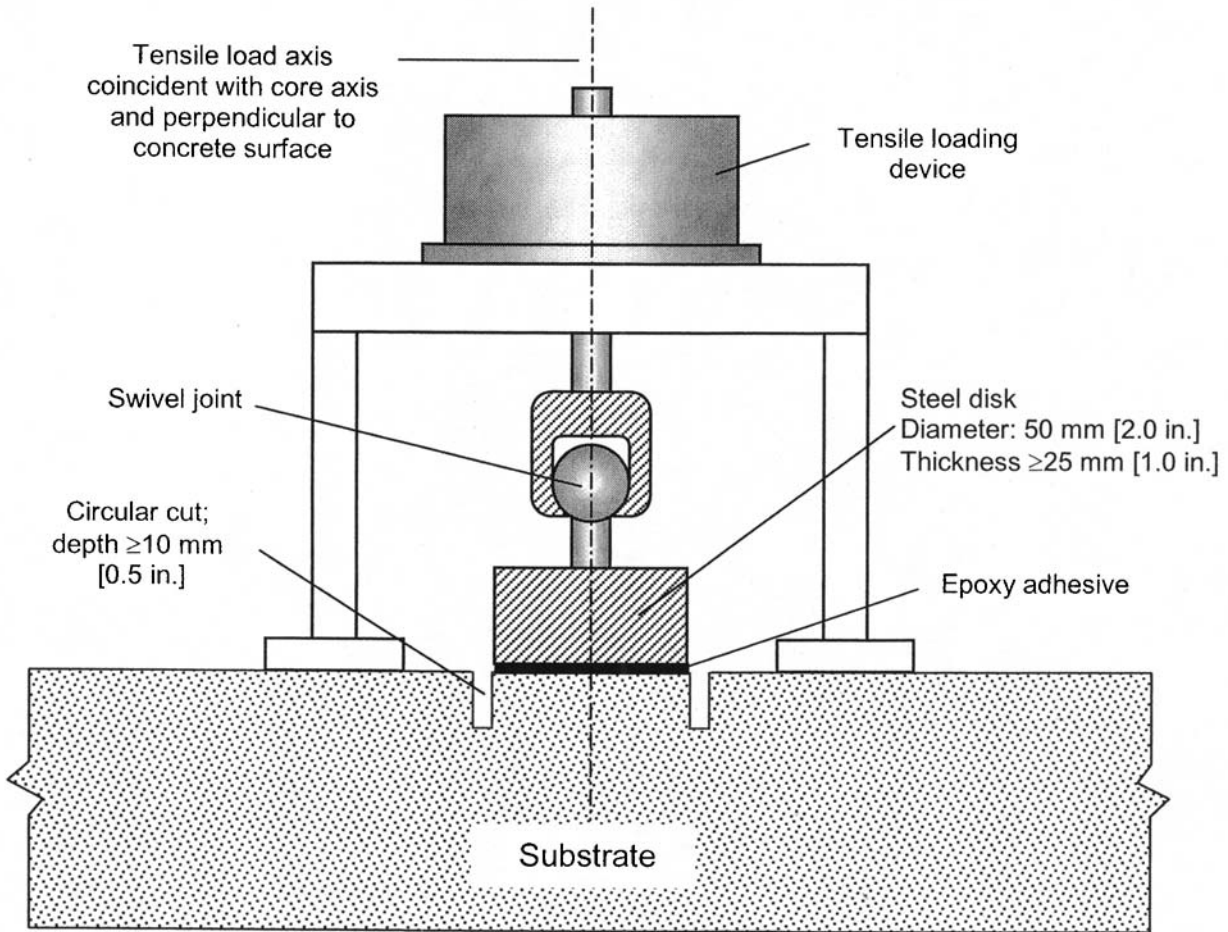

FIG. 1 Schematic of Setup to Test Substrate

Calculate the bond strength or tensile strength by dividing the tensile load at failure by the area of the test specimen:

$$\text{Bond or Tensile Strength (MPa [psi])} = \frac{\text{Tensile load (N [lbf])}}{\text{Area of test specimen (mm}^2 \text{ [in.}^2\text{])}} \quad (1)$$

11.6 Record the individual strengths to the nearest 0.01 MPa [1 psi].

11.7 Record ambient weather conditions and surface temperatures during testing.

## 12. Report

12.1 The test report shall contain the following:

12.1.1 Purpose of the test:

12.1.1.1 To assess the substrate before application of repair or overlay material with regards to the adequacy of surface preparation and the strength of the near-surface region of the substrate;

12.1.1.2 To determine the controlling failure mode and corresponding strength when a repair or an overlay material is bonded to the substrate; or

12.1.1.3 To determine the controlling failure mode and corresponding strength when an adhesive is bonded to the substrate.

12.1.2 Identification of all materials used in the test,

12.1.3 Test conditions—location of test, weather conditions, and surface temperatures, and

12.1.4 The failure mode and the tensile or bond strength for each individual test reported to the nearest 0.01 MPa [1 psi].

## 13. Precision and Bias

13.1 *Precision*—An interlaboratory testing program to determine the precision of this test method has not yet been carried out. There are, however, published data<sup>4</sup> to provide an estimate of within-test repeatability. The referenced study involved pull-off tests of repair materials applied to concrete substrates. Three replicate tests were conducted for each condition, and the mean pull-off strength ranged from 0.41 to 3.44 MPa [60 to 500 psi]. Two instruments were used with disk diameters of 75 mm [3 in.] and 50 mm [2 in.]. Replicate tests with the same failure modes were used to determine the within-test standard deviations for each condition. There was no statistically significant difference in repeatability for failures

<sup>4</sup> Vaysburd, A. M., and McDonald, J. E., "An Evaluation of Equipment and Procedures for Tensile Bond Testing of Concrete Repairs," *Technical Report REMR-CS-61*, U.S. Army Corps of Engineers, Waterways Experiment Station, June 1999, p. 84.



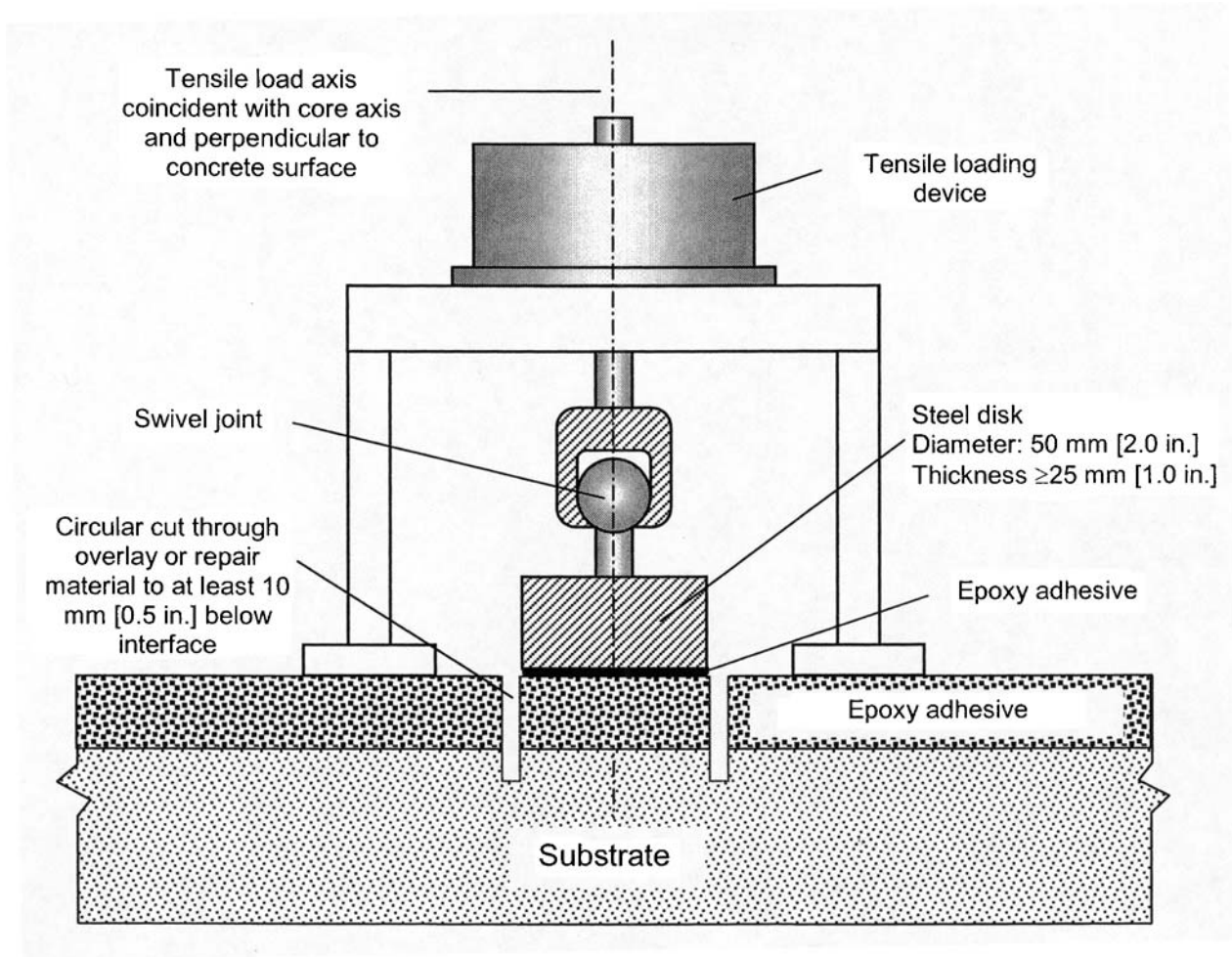

FIG. 2 Schematic of Setup to Test Material Applied to Substrate

in the substrate, the repair material, or at the interface. The overall pooled standard deviation was found to be 0.29 MPa [42 psi].

13.2 *Bias*—This method has no bias because pull-off tensile strength or pull-off bond strength are defined only in terms of this method.

#### 14. Keywords

14.1 adhesives; overlay materials; pull-off tensile strength; pull-off test; repair materials; tensile bond strength

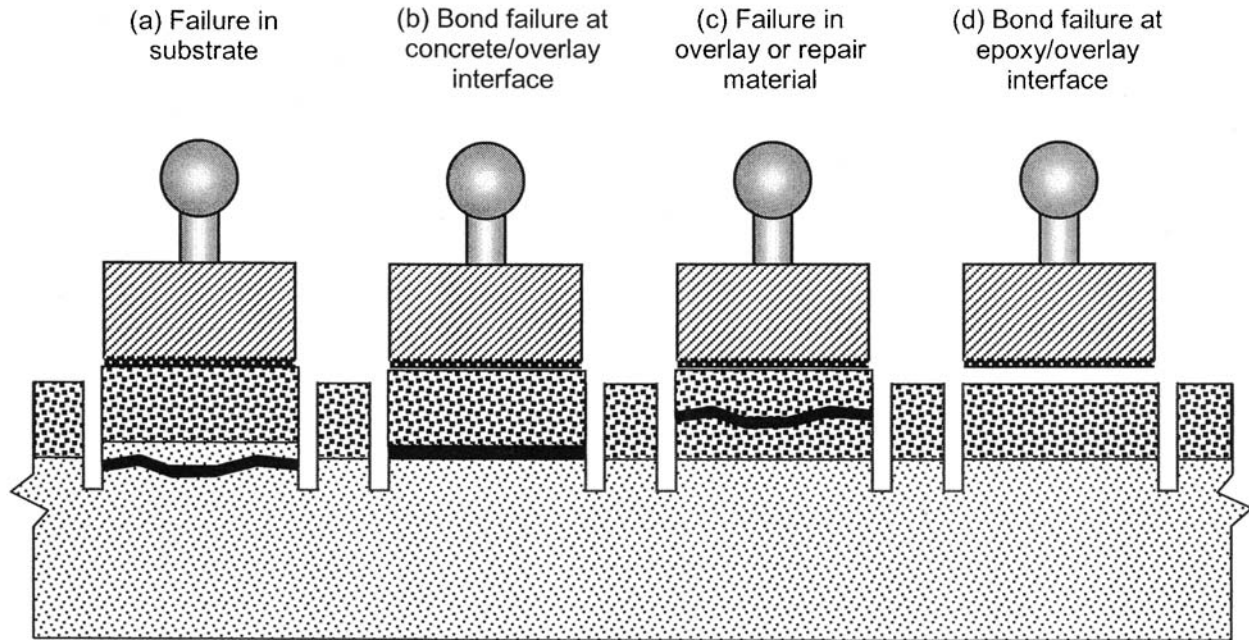

FIG. 3 Schematic of Failure Modes

ASTM International takes no position respecting the validity of any patent rights asserted in connection with any item mentioned in this standard. Users of this standard are expressly advised that determination of the validity of any such patent rights, and the risk of infringement of such rights, are entirely their own responsibility.

This standard is subject to revision at any time by the responsible technical committee and must be reviewed every five years and if not revised, either reapproved or withdrawn. Your comments are invited either for revision of this standard or for additional standards and should be addressed to ASTM International Headquarters. Your comments will receive careful consideration at a meeting of the responsible technical committee, which you may attend. If you feel that your comments have not received a fair hearing you should make your views known to the ASTM Committee on Standards, at the address shown below.

This standard is copyrighted by ASTM International, 100 Barr Harbor Drive, PO Box C700, West Conshohocken, PA 19428-2959, United States. Individual reprints (single or multiple copies) of this standard may be obtained by contacting ASTM at the above address or at 610-832-9585 (phone), 610-832-9555 (fax), or service@astm.org (e-mail); or through the ASTM website (www.astm.org).