



Standard Test Method for Fundamental Transverse, Longitudinal, and Torsional Resonant Frequencies of Concrete Specimens¹

This standard is issued under the fixed designation C 215; the number immediately following the designation indicates the year of original adoption or, in the case of revision, the year of last revision. A number in parentheses indicates the year of last reapproval. A superscript epsilon (ϵ) indicates an editorial change since the last revision or reapproval.

^{ε1} NOTE—The values for “cylinder” and “prism” in 9.1 were editorially corrected in April 1999.

1. Scope

1.1 This test method covers measurement of the fundamental transverse, longitudinal, and torsional resonant frequencies of concrete prisms and cylinders for the purpose of calculating dynamic Young’s modulus of elasticity, the dynamic modulus of rigidity (sometimes designated as “the modulus of elasticity in shear”), and dynamic Poisson’s ratio.

1.2 Values in SI units are the standard.

1.3 *This standard does not purport to address all of the safety concerns, if any, associated with its use. It is the responsibility of the user of this standard to establish appropriate safety and health practices and determine the applicability of regulatory limitations prior to use.*

2. Referenced Documents

2.1 ASTM Standards:

- C 31 Practice for Making and Curing Concrete Test Specimens in the Field²
- C 42 Test Method for Obtaining and Testing Drilled Cores and Sawed Beams of Concrete²
- C 192 Practice for Making and Curing Concrete Test Specimens in the Laboratory²
- C 469 Test Method for Static Modulus Elasticity and Poisson’s Ratio of Concrete in Compression²
- C 670 Practice for Preparing Precision and Bias Statements for Test Methods for Construction Materials²

3. Summary of Test Method

3.1 The fundamental resonant frequencies are determined using one of two alternative procedures: (1) the forced resonance method or (2) the impact resonance method. The same testing procedure is used for all specimens of an associated series.

3.2 In the forced resonance method, a supported specimen is forced to vibrate by an electro-mechanical driving unit. The specimen response is monitored by a lightweight pickup unit

on the specimen. The driving frequency is varied until the measured specimen response reaches a maximum amplitude. The value of the frequency causing maximum response is the resonant frequency of the specimen. The fundamental frequencies for the three different modes of vibration are obtained by proper location of the driver and the pickup unit.

3.3 In the impact resonance method, a supported specimen is struck with a small impactor and the specimen response is measured by a lightweight accelerometer on the specimen. The output of the accelerometer is recorded. The fundamental frequency of vibration is determined by using digital signal processing methods or counting zero crossings in the recorded waveform. The fundamental frequencies for the three different modes of vibration are obtained by proper location of the impact point and the accelerometer.

4. Significance and Use

4.1 This test method is intended primarily for detecting significant changes in the dynamic modulus of elasticity of laboratory or field test specimens that are undergoing exposure to weathering or other types of potentially deteriorating influences.

4.2 The value of the dynamic modulus of elasticity obtained by this test method will, in general, be greater than the static modulus of elasticity obtained by using Test Method C 469. The difference depends, in part, on the strength level of the concrete.

4.3 The conditions of manufacture, the moisture content, and other characteristics of the test specimens (see section on Test Specimens) materially influence the results obtained.

4.4 Different computed values for the dynamic modulus of elasticity may result from widely different resonant frequencies of specimens of different sizes and shapes of the same concrete. Therefore, comparison of results from specimens of different sizes or shapes should be made with caution.

5. Apparatus

5.1 Forced Resonance Apparatus (Fig. 1):

5.1.1 *Driving Circuit*—The driving circuit shall consist of a variable frequency audio oscillator, an amplifier, and a driving unit. The oscillator shall be calibrated to read within $\pm 2\%$ of the true frequency over the range of use (about 100 to 10 000

¹ This test method is under the jurisdiction of ASTM Committee C-9 on Concrete and Concrete Aggregates and is the direct responsibility of Subcommittee C09.64 on Nondestructive and In-Place Testing.

Current edition approved Aug. 10, 1997. Published June 1998. Originally published as C 215 – 47 T. Last previous edition C 215 – 91.

² *Annual Book of ASTM Standards*, Vol 04.02.

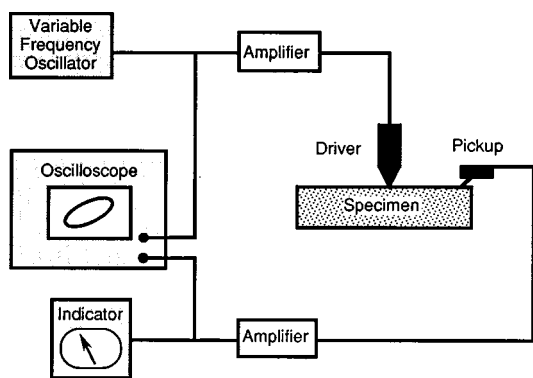

FIG. 1 Schematic of Apparatus for Forced Resonance Test

Hz). The combined oscillator and amplifier shall be capable of delivering sufficient power output to induce vibrations in the test specimen at frequencies other than the fundamental and shall be provided with a means for controlling the output. The driving unit for creating the vibration in the specimen shall be capable of handling the full power output of the oscillator and amplifier. This unit may be used in contact with the test specimen or separated from the specimen by an air gap. When the test specimen is contact-driven, the vibrating parts of the driving unit shall be small in mass as compared with that of the specimen. The oscillator and amplifier shall be capable of producing a voltage that does not vary more than $\pm 20\%$ over the frequency range and, in combination with the driving unit, shall be free from spurious resonances that will be reflected in the output.

NOTE 1—It is recommended that the calibration of the variable frequency audio oscillator be checked periodically against signals transmitted by the National Institute of Standards and Technology radio station WWV, or against suitable electronic equipment such as a frequency counter, the calibration of which has been previously checked and found to be adequate.

5.1.2 *Pickup Circuit*—The pickup circuit shall consist of a pickup unit, an amplifier, and an indicator. The pickup unit shall generate a voltage proportional to the displacement, velocity, or acceleration of the test specimen, and the vibrating parts shall be small in mass compared with the mass of the test specimen. Either a piezoelectric or magnetic pickup unit meeting these requirements may be used. The amplifier shall have a controllable output of sufficient magnitude to actuate the indicator. The indicator shall consist of a voltmeter, milliammeter, or cathode-ray oscilloscope. For routine testing of specimens whose fundamental frequency may be anticipated within reasonable limits, a meter-type indicator is satisfactory and may be more convenient to use than a cathode-ray oscilloscope. It is, however, strongly recommended that whenever feasible a cathode-ray oscilloscope be provided for supplementary use or to replace the meter-type indicator. The use of an oscilloscope as an indicator may be necessary when specimens are to be tested for which the fundamental frequency range is unpredictable. The oscilloscope is valuable also for checking the equipment for drift and for use in the event that it should be desired to use the equipment for certain other purposes than those specifically contemplated by this method of test. The response of the pickup unit shall be

proportional to the motion of the test specimen in accordance with the characteristics of the type of pickup selected, and shall be free from spurious resonances in the normal operating range.

5.1.3 *Specimen Support*—The support shall permit the specimen to vibrate freely. This may be accomplished by placing the specimen on soft rubber supports located near the nodal points or on a thick pad of sponge rubber. The location of the nodal points for the different modes of vibration are described in Note 2, Note 3, and Note 4. The support system shall be dimensioned so that its resonant frequency falls outside the range of use (100 to 10 000 Hz).

5.2 *Impact Resonance Apparatus* (Fig. 2):

5.2.1 *Impactor*—The impactor shall be made of steel or rigid plastic and the mass of the head shall be 0.11 ± 0.02 kg. The striking end of the impactor shall have a spherical shape with a diameter of 6 ± 1 mm.

5.2.2 *Sensor*—The sensor shall be a piezoelectric accelerometer with a mass less than 27 g and having an operating frequency range of 100 to 10 000 Hz. The resonant frequency of the accelerometer shall be at least two times the maximum operating frequency.

5.2.3 *Frequency Analyzer*—The frequency of the specimen vibration may be determined by using either a digital waveform analyzer or a frequency counter to analyze the signal measured by the sensor. The waveform analyzer shall have a sampling rate of at least 20 kHz and shall record at least 1024 points of the waveform. The frequency counter shall have an accuracy of $\pm 1\%$ over the range of use.

5.2.4 *Specimen Support*—Support shall be provided as specified in 5.1.3 for the forced resonance method.

6. Test Specimens

6.1 *Preparation*—Make the cylindrical or prismatic test specimens in accordance with Practice C 192, Practice C 31, Test Method C 42, or other specified procedures.

6.2 *Measurement of Mass and Dimensions*—Determine the mass and average length of the specimens within $\pm 0.5\%$. Determine the average cross-sectional dimensions within $\pm 1\%$.

6.3 *Limitations on Dimensional Ratio*—Specimens having either very small or very large ratios of length to maximum transverse direction are frequently difficult to excite in the fundamental mode of vibration. Best results are obtained when this ratio is between 3 and 5. For application of the formulas in this test method, the ratio must be at least 2.

7. Determination of Resonant Frequencies—Forced Resonance Method

7.1 *Transverse Frequency*:

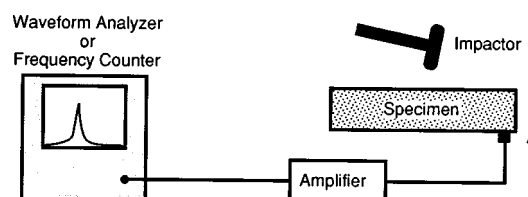

FIG. 2 Schematic of Apparatus for Impact Resonance Test

7.1.1 Support the specimen so that it may vibrate freely in the transverse mode (Note 2). Position the specimen and driver so that the driving force is perpendicular to the surface of the specimen. Locate the driving unit at the approximate middle of the specimen. Place the pickup unit on the specimen so that the direction of pickup sensitivity coincides with the vibration direction, that is, the transverse direction (see Fig. 3a). Position the pickup near one end of the specimen. It is permissible to position the driver on the vertical face so that the specimen vibrates perpendicular to the direction shown in Fig. 3a.

7.1.2 Force the test specimen to vibrate at varying frequencies. At the same time, observe the indication of the amplified output of the pickup. Record the fundamental transverse frequency of the specimen, which is the frequency at which the indicator shows the maximum reading and observation of nodal points indicates fundamental transverse vibration (Note 2). Adjust the amplifiers in the driving and pickup circuits to provide a satisfactory indication. To avoid distortion, maintain the driving force as low as is feasible for good response at resonance.

NOTE 2—For fundamental transverse vibration, the nodal points are located 0.224 of the length of the specimen from each end (approximately the quarter points). Vibrations are a maximum at the ends, approximately three fifths of the maximum at the center, and zero at the nodal points; therefore, movement of the pickup along the length of the specimen will inform the operator whether the vibrations observed in the indicator are from the specimen vibrating in its fundamental transverse mode. A cathode-ray oscilloscope may also be used to determine whether the specimen is vibrating in its fundamental transverse mode. The driver signal is connected to the horizontal sweep and the pickup signal is connected to the vertical sweep of the oscilloscope. When the pickup is located at the end of the specimen, which is vibrating in its fundamental transverse mode, the oscilloscope will display an inclined elliptical pattern. When the pickup is placed at a node, the oscilloscope displays a horizontal line. When the pickup is placed at the center of the specimen, the display will be an elliptical pattern but inclined in the opposite direction to when the pickup was placed at the end of the specimen. The

cathode-ray oscilloscope can also be used to verify that the driving frequency is the fundamental resonant frequency. Resonance can occur when the driving frequency is a fraction of the fundamental frequency. However, in this case the oscilloscope pattern will not be an ellipse.

7.2 Longitudinal Frequency:

7.2.1 Support the specimen so that it may vibrate freely in the longitudinal mode (Note 3). Position the specimen and driver so that the driving force is perpendicular to and approximately at the center of one end surface of the specimen. Place the pickup unit on the specimen so that the direction of pickup sensitivity coincides with the vibration direction, that is, the longitudinal axis of the specimen (see Fig. 3b).

7.2.2 Force the test specimen to vibrate at varying frequencies. At the same time, observe the indication of the amplified output of the pickup. Record the fundamental longitudinal frequency of the specimen, which is the frequency at which the indicator shows the maximum reading and observation of the nodal point indicates fundamental longitudinal vibration (Note 3).

NOTE 3—For the fundamental longitudinal mode, there is one node at the center of length of the specimen. Vibrations are a maximum at the ends.

7.3 Torsional Frequency:

7.3.1 Support the specimen so that it may vibrate freely in the torsional mode (Note 4). Position the specimen and driver so that the driving force is perpendicular to the surface of the specimen. For prismatic specimens, locate the driving unit near the upper or lower edge of the specimen at a distance from the end that is between 0.10 and 0.12 of the length of the specimen (see Fig. 3c). For cylindrical specimens, locate the driving unit above or below the mid-line of the cylinder. Place the pickup unit on the surface of the specimen at a position on the opposite end that coincides with the node point for fundamental transverse vibration (see Fig. 3a). Position the pickup so that the direction of pickup sensitivity coincides with the vibration direction, that is, perpendicular to the longitudinal axis of the specimen.

7.3.2 Force the test specimen to vibrate at varying frequencies. At the same time, observe the indication of the amplified output of the pickup. Record the fundamental torsional frequency of the specimen, which is the frequency at which the indicator shows the maximum reading and observation of the nodal point indicates fundamental torsional vibration (Note 4).

NOTE 4—For the fundamental torsional mode, there is one node at the center of the specimen. Vibrations are maximum at the ends. Locating the driving unit and pickup as shown in Fig. 3c minimizes interferences from transverse vibrations which can occur simultaneously with torsional vibration.

8. Determination of Resonant Frequencies—Impact Resonance Method

8.1 Transverse Frequency:

8.1.1 Support the specimen so that it may vibrate freely in the transverse mode (Note 2). Attach the accelerometer near the end of the specimen as shown in Fig. 3a.

NOTE 5—The accelerometer may be attached to the specimen using soft wax or other suitable materials, such as glue or grease. If the specimen is wet, an air jet may be used to surface dry the region where the accelerometer is to be attached. Alternatively, the accelerometer may be

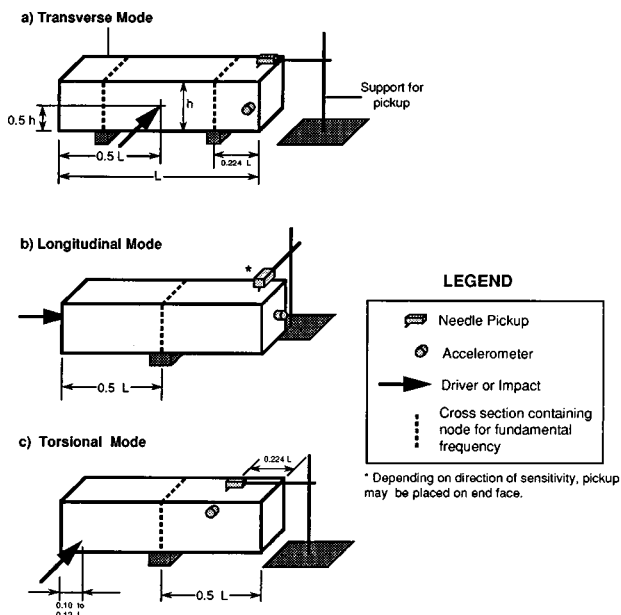

FIG. 3 Locations of Driver (or Impact) and Needle Pickup (or Accelerometer)

held in position with a rubber band, but a coupling material should still be used to ensure good contact with the specimen.

8.1.2 Prepare the waveform analyzer or frequency counter for recording data. Set the digital waveform analyzer to a sampling rate of 20 kHz (Note 6) and a record length of 1024 points. Use the accelerometer signal to trigger data acquisition. Using the impactor, strike the specimen perpendicular to the surface and at the approximate middle of the specimen.

NOTE 6—The sampling frequency must be at least twice the resonant frequency of the specimen. A sampling frequency of 20 kHz is applicable to specimens with a resonant frequency less than 10 kHz, which is typical of the usual laboratory specimens. When higher resonant frequencies are involved, increase the sampling frequency accordingly.

8.1.3 Record the resonant frequency indicated by the waveform analyzer (Note 7) or frequency counter. Repeat the test two more times, and record the average transverse resonant frequency. If a frequency measurement deviates from the average value by more than 10 %, disregard that measurement and repeat the test. When using a frequency counter based on zero crossings, the start of recording should be delayed until approximately the first 10 cycles of transverse vibration have occurred (Note 8).

NOTE 7—When using a waveform analyzer, the resonant frequency is the frequency with the highest peak in the amplitude spectrum or the power spectrum obtained from the fast Fourier transform of the recorded accelerometer signal. The fundamental resonant frequency can be verified by impacting the specimen at one of the nodal points. The amplitude spectrum should show a small or no peak at the value of the fundamental frequency.

NOTE 8—Care should be exercised when using a test instrument based on the zero-crossing method to evaluate the resonant frequency of a specimen which is undergoing degradation, such as by cycles of freezing and thawing. As the specimen degrades, the damping value increases and the amplitude of vibration after impact decays more rapidly compared with an undamaged specimen. For accurate determination of frequency, the duration of the sampling time must be compatible with the decay time of the specimen. In addition, a lower number of cycles of delay prior to starting the sampling record may be acceptable.

8.2 Longitudinal Frequency:

8.2.1 Support the specimen so that it may vibrate freely in the longitudinal mode (Note 3). Attach the accelerometer (Note 5) at the approximate center of one end surface of the specimen as shown in Fig. 3b.

8.2.2 Prepare the waveform analyzer or frequency counter for recording data. Set the digital waveform analyzer to a sampling rate of 20 kHz (Note 7) and a record length of 1024 points. Use the accelerometer signal to trigger data acquisition. Using the impactor, strike the specimen perpendicular to and at the approximate center of the end surface without the accelerometer.

8.2.3 Record the resonant frequency indicated by the waveform analyzer (Note 7) or frequency counter. Repeat the test two more times, and record the average longitudinal resonant frequency. If a frequency measurement deviates from the average value by more than 10 %, disregard that measurement

and repeat the test. When using a frequency counter based on zero crossings, the start of recording should be delayed until approximately the first 30 cycles of longitudinal vibration have occurred, and care should be taken to ensure a perpendicular impact with the surface (Note 8).

8.3 Torsional Frequency:

8.3.1 Support the specimen so that it may vibrate freely in the torsional mode (Note 4). For a prismatic specimen, attach the accelerometer near an edge of the specimen at a cross section that contains a node point for fundamental transverse vibration as shown in Fig. 3c. For a cylindrical specimen, mount the accelerometer so that its direction of sensitivity is tangential to a circular cross section which contains a node point for fundamental transverse vibration. One approach is to attach the accelerometer to a tab glued to the cylinder as shown in Fig. 4.

8.3.2 Prepare the waveform analyzer or frequency counter for recording data. Set the digital waveform analyzer to a sampling rate of 20 kHz (Note 7) and a record length of 1024 points. Use the accelerometer signal to trigger data acquisition. For prismatic specimens, strike the specimen with the impactor at a point near the upper or lower edge of the specimen at a distance from the end that is 0.132 ± 0.01 of the length of the specimen (see Fig. 3c). For cylindrical specimens, strike the specimen at a similar distance from the end as shown in Fig. 4.

8.3.3 Record the resonant frequency indicated by the waveform analyzer (Note 7) or frequency counter. Repeat the test two more times, and record the average torsional resonant frequency. If a frequency measurement deviates from the average value by more than 10 %, disregard that measurement and repeat the test. When using a frequency counter based on zero crossings, the start of recording should be delayed until approximately the first 10 cycles of torsional vibration have occurred (Note 8).

9. Calculation

9.1 Calculate dynamic Young's modulus of elasticity, E , in newtons per square metre (pascals) from the fundamental transverse frequency, mass, and dimensions of the test specimen as follows:

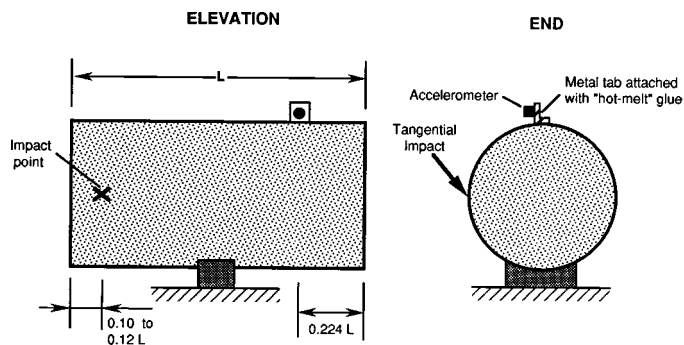

FIG. 4 Locations of Impact and Accelerometer for Torsional Mode of a Cylinder

 **C 215**

$$\text{Dynamic } E = CMn^2 \quad (1)$$

where:

- M = mass of specimen, kg,
- n = fundamental transverse frequency, Hz,
- C = 1.6067 (L^3T/d^4), $N \cdot s^2/(kg \cdot m^2)$ for a cylinder, or
= 0.9464 (L^3T/bt^3), $N \cdot s^2/(kg \cdot m^2)$ for a prism,
- L = length of specimen, m,
- d = diameter of cylinder, m,
- t, b = dimensions of cross section of prism, m, t being in the direction in which it is driven, and
- T = a correction factor which depends on the ratio of the radius of gyration, K (the radius of gyration for a cylinder is $d/4$ and for a prism is $t/3.464$), to the length of the specimen, L , and on Poisson's ratio. Values of T for Poisson's ratio of $1/6$ may be obtained from Table 1.

9.2 Calculate dynamic Young's modulus of elasticity, E , in newtons per square metre (Pa) from the fundamental longitudinal frequency, mass, and dimensions of the test specimen as follows:

$$\text{Dynamic } E = DM(n')^2 \quad (2)$$

where:

- n' = fundamental longitudinal frequency, Hz, and
- D = 5.093 (L/d^2), $N \cdot s^2/(kg \cdot m^2)$ for a cylinder, or
= 4 (L/bt), $N \cdot s^2/(kg \cdot m^2)$ for a prism.

9.3 Calculate dynamic modulus of rigidity, G , in newtons per square metre (pascals) from the fundamental torsional frequency, mass, and dimensions of the test specimen as follows:

$$\text{Dynamic } G = BM(n'')^2 \quad (3)$$

where:

- n'' = fundamental torsional frequency, Hz,
- B = ($4LR/A$), $N \cdot s^2/(kg \cdot m^2)$,
- R = a shape factor,
= 1 for a circular cylinder,
= 1.183 for a square cross-section prism,
= ($a/b + b/a$)/[$4a/b - 2.52(a/b)^2 + 0.21(a/b)^6$] for a rectangular prism whose cross-sectional dimensions are a and b in., with a less than b , and
- A = cross-sectional area of test specimen, m^2 .

9.4 Calculate Poisson's ratio, the ratio of lateral to longitudinal strain for an isotropic substance, μ , as follows:

$$\mu = (E/2G) - 1 \quad (4)$$

9.4.1 When the values of E and G used above are dynamic values, Poisson's ratio should be designated as dynamic Poisson's ratio.

NOTE 9—Values for Poisson's ratio for concrete normally vary between about 0.10 for dry specimens and 0.25 for saturated specimens. Higher values are expected for concrete tested at early ages.

10. Report

- 10.1 Report the following for each specimen:
 - 10.1.1 Identification number,
 - 10.1.2 Cross-sectional dimensions within 0.1 %,
 - 10.1.3 Length within 0.5 %,
 - 10.1.4 Mass within 0.5 %,
 - 10.1.5 Description of any defects that may be present, and
 - 10.1.6 Mode of vibration and corresponding resonant frequency to the nearest 10 Hz.

10.2 If the dynamic Young's modulus of elasticity or dynamic modulus of rigidity are calculated, report to the nearest 0.5 GPa.

10.3 If the dynamic Poisson's ratio is calculated, report to the nearest 0.01.

11. Precision and Bias

11.1 The data used to develop the precision statements were obtained using an earlier inch-pound version of this test method.

11.2 *Precision of Forced Resonance Method*—The following precision statements are for fundamental transverse frequency only, determined on concrete prisms as originally cast. They do not necessarily apply to concrete prisms after they have been subjected to freezing-and-thawing tests. At the present time, data appropriate for determining precision of fundamental torsional and longitudinal frequencies are not available.

11.2.1 *Single-Operator Precision*—Criteria for judging the acceptability of measurements of fundamental transverse frequency obtained by a single operator in a single laboratory on concrete specimens made from the same materials and subjected to the same conditions are given in Table 2. These limits apply over the range of fundamental transverse frequency from 1400 to 3300 Hz. The different specimen sizes represented by the data include the following (the first dimension is the direction of vibration):

TABLE 1 Values of Correction Factor, T

| K/L | Value of T^A | | | |
|------|----------------|--------------|--------------|--------------|
| | $\mu = 1/6$ | $\mu = 0.20$ | $\mu = 0.23$ | $\mu = 0.26$ |
| 0.00 | 1.00 | 1.00 | 1.00 | 1.00 |
| 0.01 | 1.01 | 1.01 | 1.01 | 1.01 |
| 0.02 | 1.03 | 1.03 | 1.03 | 1.03 |
| 0.03 | 1.07 | 1.07 | 1.07 | 1.07 |
| 0.04 | 1.13 | 1.13 | 1.13 | 1.14 |
| 0.05 | 1.20 | 1.20 | 1.21 | 1.21 |
| 0.06 | 1.28 | 1.28 | 1.29 | 1.29 |
| 0.07 | 1.38 | 1.38 | 1.39 | 1.39 |
| 0.08 | 1.48 | 1.49 | 1.49 | 1.50 |
| 0.09 | 1.60 | 1.61 | 1.61 | 1.62 |
| 0.10 | 1.73 | 1.74 | 1.75 | 1.76 |
| 0.12 | 2.03 | 2.04 | 2.05 | 2.07 |
| 0.14 | 2.36 | 2.38 | 2.39 | 2.41 |
| 0.16 | 2.73 | 2.75 | 2.77 | 2.80 |
| 0.18 | 3.14 | 3.17 | 3.19 | 3.22 |
| 0.20 | 3.58 | 3.61 | 3.65 | 3.69 |
| 0.25 | 4.78 | 4.84 | 4.89 | 4.96 |
| 0.30 | 6.07 | 6.15 | 6.24 | 6.34 |

^AValues of T for Poisson's ratio of $1/6$ are derived from Fig. 1 of the paper by Gerald Pickett, "Equations for Computing Elastic Constants from Flexural and Torsional Resonant Frequencies of Vibration of Prisms and Cylinders," *Proceedings*, ASTEA, Am. Soc. Testing Mats., Vol 45, 1945, p. 846-863.

Poisson's ratio for water-saturated concrete may be higher than $1/6$. The correction factor, T , for other values of Poisson's ratio, μ , and given K/L , are calculated from the following relationship:

$$T' = T \left[\frac{1 + (0.26\mu + 3.22\mu^2)K/L}{1 + 0.1328 K/L} \right] \quad (5)$$

where T is the value for $\mu = 1/6$ shown in the second column of Table 1 for the given K/L .

TABLE 2 Test Results for Single Operator in a Single Laboratory

| | Coefficient of Variation, % ^A | Acceptable Range of Two Results, % of Average ^A |
|---|--|--|
| Within-batch single specimen | 1.0 | 2.8 |
| Within-batch, average of 3 specimens ^B | 0.6 | 1.7 |
| Between-batch, average of 3 specimens per batch | 1.0 | 2.8 |

^AThese numbers represent, respectively, the 1s % and d2s % limits as described in Practice C 670.

^BCalculated as described in Practice C 670.

76 by 102 by 406 mm
102 by 76 by 406 mm
89 by 114 by 406 mm
76 by 76 by 286 mm
102 by 89 by 406 mm
76 by 76 by 413 mm

NOTE 10—The coefficients of variation for fundamental transverse frequency have been found to be relatively constant over the range of frequencies given for a range of specimen sizes and age or condition of the concrete, within limits.

11.2.2 *Multilaboratory Precision*—The multilaboratory coefficient of variation for averages of three specimens from a single batch of concrete has been found to be 3.9 % for fundamental transverse frequencies over the range from 1400 to 3300 Hz (Note 11). Therefore, two averages of three

specimens from the same batch tested in different laboratories should not differ by more than 11.0 % of their common average (see Note 11).

NOTE 11—These numbers represent, respectively, the 1s % and d2s % limits as described in Practice C 670.

11.3 *Precision of Impact Resonance Method*—The precision of this test method has yet to be determined. However, experience has shown that, when a frequency analyzer is used, replicate tests on the same specimen result in resonant frequency values that are within ± 1 digital step of each other (Note 12).

NOTE 12—The digital step in the amplitude spectrum equals the sampling frequency divided by number of points in the time domain waveform. For example, for a sampling frequency of 20 kHz (50- μ s sample interval) and 1024 points in the waveform, the digital step is $20\,000/1024 = 19.5$ Hz.

11.4 *Bias*—The bias of either the forced resonance method or the impact resonance method has not been determined because there are no reference samples available.

12. Keywords

12.1 dynamic modulus of rigidity; dynamic Poisson's ratio; dynamic Young's modulus of elasticity; forced resonance; fundamental resonant frequency; impact resonance; nondestructive testing

The American Society for Testing and Materials takes no position respecting the validity of any patent rights asserted in connection with any item mentioned in this standard. Users of this standard are expressly advised that determination of the validity of any such patent rights, and the risk of infringement of such rights, are entirely their own responsibility.

This standard is subject to revision at any time by the responsible technical committee and must be reviewed every five years and if not revised, either reapproved or withdrawn. Your comments are invited either for revision of this standard or for additional standards and should be addressed to ASTM Headquarters. Your comments will receive careful consideration at a meeting of the responsible technical committee, which you may attend. If you feel that your comments have not received a fair hearing you should make your views known to the ASTM Committee on Standards, 100 Barr Harbor Drive, West Conshohocken, PA 19428.