



Designation: C 289 – 023

Standard Test Method for Potential Alkali-Silica Reactivity of Aggregates (Chemical Method)¹

This standard is issued under the fixed designation C 289; the number immediately following the designation indicates the year of original adoption or, in the case of revision, the year of last revision. A number in parentheses indicates the year of last reapproval. A superscript epsilon (ϵ) indicates an editorial change since the last revision or reapproval.

This standard has been approved for use by agencies of the Department of Defense.

1. Scope*

1.1 This test method covers chemical determination of the potential reactivity of an aggregate with alkalis in portland-cement concrete as indicated by the amount of reaction during 24 h at 80°C between 1 *N* sodium hydroxide solution and aggregate that has been crushed and sieved to pass a 300- μm sieve and be retained on a 150- μm sieve.

1.2 The values stated in SI units are to be regarded as standard.

1.3 *This standard does not purport to address all of the safety concerns, if any, associated with its use. It is the responsibility of the user of this standard to establish appropriate safety and health practices and determine the applicability of regulatory limitations prior to use.* A specific precautionary statement is given in 5.7.1.

2. Referenced Documents

2.1 *ASTM Standards:*

C 114 Test Methods for Chemical Analysis of Hydraulic Cement²

¹ This test method is under the jurisdiction of ASTM Committee C09 on Concrete and Concrete Aggregates and is the direct responsibility of Subcommittee C09.26 on Chemical Reactions of Materials.

Current edition approved July Aug. 10, 2002³. Published July 2002; October 2003. Originally published as C 289 – 52; approved in 1952. Last previous edition approved in 2002 as C 289 – 04².

*A Summary of Changes section appears at the end of this standard.

- C 227 Test Method for Potential Alkali Reactivity of Cement-Aggregate Combinations (Mortar-Bar Method)³
 C 295 Guide for Petrographic Examination of Aggregates for Concrete³
 C 702 Practice for Reducing Samples of Aggregate to Testing Size³
 C 1005 Specification for Reference Masses and Devices for Determining Mass and Volume for Use in the Physical Testing of Hydraulic Cements²
 C 1260 Test Method for Potential Alkali Reactivity of Aggregates (Mortar-Bar Method)³
 C 1293 Test Method for Determination of Length Change of Concrete Due to Alkali-Silica Reaction³
 D 75 Practice for Sampling Aggregates⁴
 D 1193 Specification for Reagent Water⁵
 D 1248 Specification for Polyethylene Plastics Extrusion Materials for Wire and Cable⁶
 E 11 Specification for Wire Cloth and Sieves for Testing Purposes⁷
 E 60 Practice for Analysis of Metals, Ores, and Related Materials by Molecular Absorption Spectrometry⁸
 2.2 *American Chemical Society Documents:*
 Reagent Chemicals, American Chemical Society Specifications

NOTE 1—For suggestions on the testing of reagents not listed by the American Chemical Society, see “Reagent Chemicals and Standards,” by Joseph Rosin, D. Van Nostrand Co., Inc., New York, NY, and the “United States Pharmacopeia.”

3. Significance and Use

3.1 ~~When this test method may be is used in combination with other methods~~ to evaluate the potential reactivity of siliceous components in the aggregate with alkalis in ~~po hydrhandulic-cement concrete, it must be used in combination with other methods.~~ Do not use the results of tests by this test method as the sole basis for acceptance or rejection for sources with regard to ASR.

3.2 Reactions between a sodium hydroxide solution and siliceous components in the aggregate have been shown to correlate with the performance of ~~th some aggregates in concrete structures and should be used where new aggregate sources are being evaluated or alkali-silica reactivity is anticipated.~~

3.2 ~~The structures. The~~ results from this test method can be obtained quickly, and, while not completely reliable in all cases, they can provide useful data that may show the need for obtaining additional information through Test Method C 227 and Guide C 295. ~~data.~~

3.3 This test method can be employed as a quality control tool to periodically check samples from an existing source with an acceptable service history.

4. Apparatus

4.1 *Scales*—The scales and weights used for weighing materials shall conform to the requirements prescribed in ~~Test Method Specification C 1005.~~

4.2 *Balances*—The analytical balance and weights used for determining dissolved silica by the gravimetric method shall conform to the requirements prescribed in Test Methods C 114.

4.3 *Crushing and Grinding Equipment*—A small jaw crusher and disk pulverizer or other suitable equipment capable of crushing and grinding aggregate to pass a 300- μ m sieve.

4.4 *Sieves:*

4.4.1 300- μ m and 150- μ m square-hole, woven wire-cloth sieves conforming to Specification E 11.

4.4.2 A 4.75-mm (No. 4) sieve.

4.5 *Containers*—Reaction containers of 50 to 75-mL capacity, made of corrosion-resistant steel or other corrosion-resistant material, and fitted with airtight covers. A container that has been found suitable is shown in Fig. 1. Other containers, made of corrosion-resistant material such as polyethylene, may be suitable. Such suitability can be demonstrated by a change in the alkalinity of the sodium hydroxide solution (R_c , Section on Reduction in Alkalinity) when used alone as a blank in the container in question, of less than 10 mmol/L.

4.6 *Constant-Temperature Bath*—A liquid bath capable of maintaining a temperature of $80 \pm 1^\circ\text{C}$ for 24 h.

4.7 *Spectrophotometer or Photometer*—A spectrophotometer or photoelectric photometer capable of measuring the transmission of light at a constant wavelength of approximately 410 nm (see Practice E 60).

4.8 *Glassware*—All glass apparatus and vessels should be carefully selected to meet the particular requirements for each operation. Standard volumetric flasks, burets, and pipets should be of precision grade.

5. Reagents

5.1 *Purity of Reagents*—Reagent grade chemicals shall be used in all tests. Unless otherwise indicated, all reagents shall

² *Annual Book of ASTM Standards*, Vol 04.01.

³ *Annual Book of ASTM Standards*, Vol 04.02.

⁴ *Annual Book of ASTM Standards*, Vol 04.03.

⁵ *Annual Book of ASTM Standards*, Vol 11.01.

⁶ *Annual Book of ASTM Standards*, Vol 08.01.

⁷ *Annual Book of ASTM Standards*, Vol 14.02.

⁸ *Annual Book of ASTM Standards*, Vol 03.05.

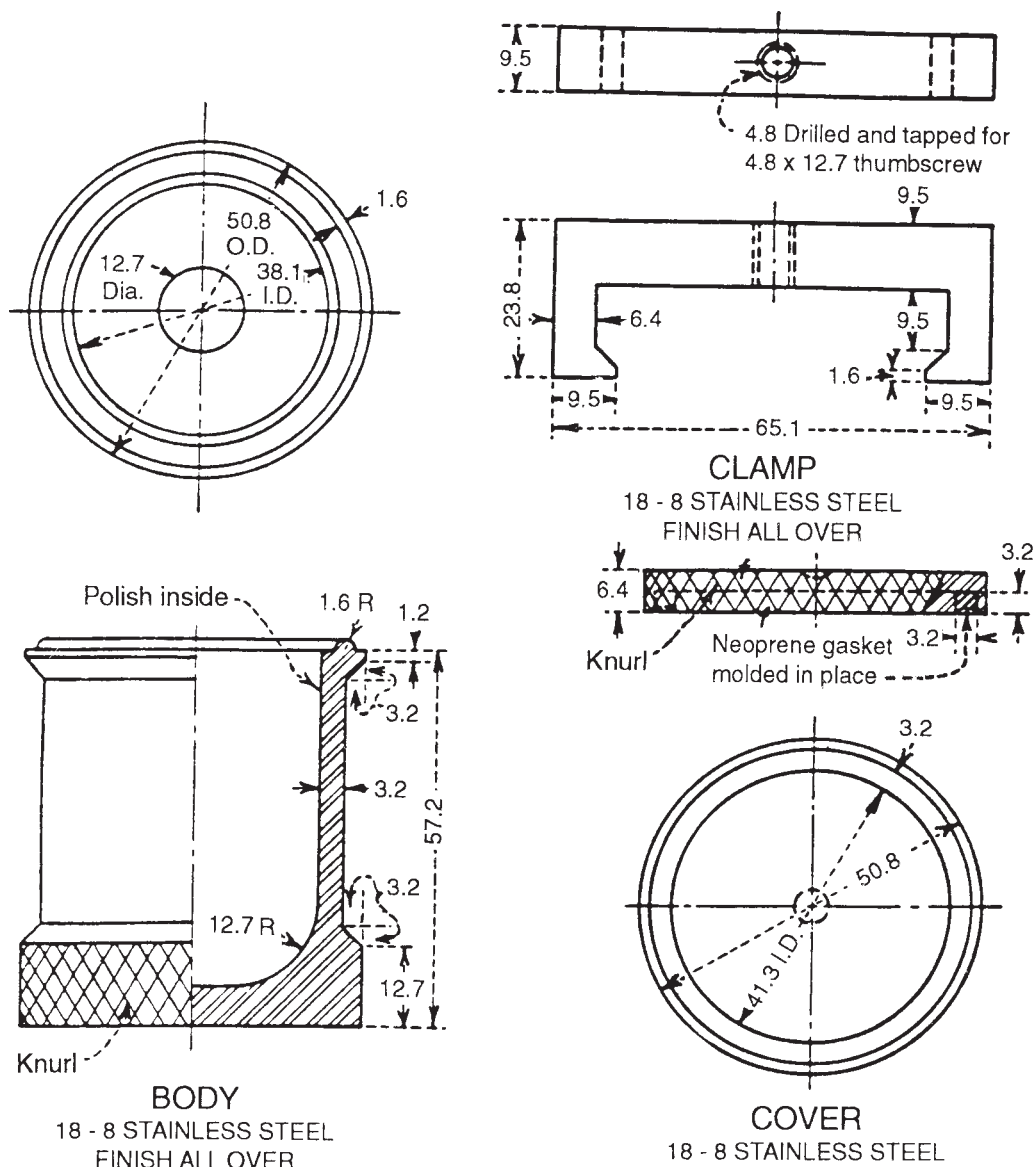

NOTE 1—All dimensions are in mm.

FIG. 1 Reaction Container

conform to the specifications of the Committee on Analytical Reagents of the American Chemical Society, where such specifications are available. Other grades may be used, provided it is first ascertained that the reagent is of sufficiently high purity to permit its use without lessening the accuracy of the determination.

5.2 *Purity of Water*—Unless otherwise indicated, references to water shall be understood to mean reagent water conforming to Type IV of Specification D 1193.

5.3 *Ammonium Molybdate Solution*—Dissolve 10 g of ammonium molybdate ($(\text{NH}_4)_6 \text{Mo}_7\text{O}_{24} \cdot 4\text{H}_2\text{O}$) in 100 mL of water. If the solution is not clear, filter through a fine-texture paper. Store the solution in a polyethylene container (see Note 2).

5.4 *Hydrochloric Acid (1.19 kg/L)*—Concentrated hydrochloric acid (HCl). Store the solution in a chemically resistant glass or suitable plastic container (see Note 2).

5.5 *Hydrochloric Acid, Standard (0.05 N)*—Prepare approximately 0.05 N HCl and standardize to ± 0.0001 N. Store the solution in a chemically resistant glass or suitable plastic container (see Note 2).

5.6 *Hydrochloric Acid (1 + 1)*—Mix equal volumes of concentrated HCl (1.19 kg/L) and water. Store the solution in a chemically resistant glass or suitable plastic container (see Note 2).

5.7 *Hydrofluoric Acid (approximately 50 % HF)*—Concentrated hydrofluoric acid. Store in a polyethylene bottle (see Note 2).

5.7.1 **Warning**—Before using HF, review (1) the safety precautions for using HF, (2) first aid for burns, and (3) the emergency response to spills, as described in the manufacturer's Material Safety Data Sheet or other reliable safety literature. HF can cause very severe burns and injury to unprotected skin and eyes. Suitable personal protective equipment should always be used. These

should include full-face shields, rubber aprons, and gloves impervious to HF. Gloves should be checked periodically for pin holes.

5.8 *Oxalic Acid Solution*—Dissolve 10 g of oxalic acid dihydrate in 100 mL of water. Store the solution in a chemically resistant glass or suitable plastic container (see Note 2).

5.9 *Phenolphthalein Indicator Solution*—Dissolve 1 g of phenolphthalein in 100 mL of ethanol (1 + 1). Store the solution in a chemically resistant glass or suitable plastic container (see Note 2).

5.10 *Silica Standard Solution*—Prepare a standard silica solution containing approximately 10 mmol of silica (SiO_2)/L by dissolving sodium metasilicate in water. Store the solution in a polyethylene bottle. Use a 100-mL aliquot of the solution to determine its SiO_2 content by the procedure described in 8.1.1-8.2.1. Do not use a standard silica solution older than 1 year, since dissolved ionic silica in such a solution slowly polymerizes, causing spuriously low photometric readings (see Note 2).

5.11 *Sodium Hydroxide, Standard Solution* ($1.000 \pm 0.010 N$)—Prepare a $1.000 \pm 0.010 N$ sodium hydroxide (NaOH) solution and standardize to $\pm 0.001 N$. Store the solution in a polyethylene bottle (Note 2). Protect the dry reagent and solution from contamination by carbon dioxide.

5.12 *Sulfuric Acid* (sp gr 1.84)—Concentrated sulfuric acid (H_2SO_4). Store the solution in a chemically resistant glass container (see Note 2).

NOTE 2—In selecting the container, take care to ensure that the reagent will not be modified by reaction with the material composing the container, including pigments or other additives, or by transpiration of phases through the walls of the container. Containers with wall thickness not less than 0.51 mm and composed of high-density polyethylene meeting the requirements of Specification D 1248, for materials of Type III, Class A, are suitable.

6. Selection and Preparation of Test Samples

6.1 The test can be used for either fine or coarse aggregate, and when the fine and coarse aggregate are of the same material it can be used for the total aggregate.

6.2 Obtain the aggregate sample in accordance with Practice D 75. Use the sample sizes given in Table number 1 of Practice D 75.

6.2.1 For samples of aggregate with a nominal maximum size less than 19.0 mm, split the sample in half in accordance with Practice C 702. Crush one half as described in 6.2.3. Retain the other half for further testing if desired.

6.2.2 For samples of aggregate with a nominal maximum size 19.0 mm or larger, mix and quarter the sample in accordance with Practice C 702. Crush one quarter as described in 6.2.3. Retain the other three quarters of the sample for further testing if desired.

6.2.3 Crush the sample in a jaw-crusher using small portions at a time, retaining all fractions, until the sample passes a 4.75-mm (No. 4) sieve. Reduce the crushed sample to 300 ± 5 g by splitting in accordance with Practice C 702.

6.3 Sieve the 300-g sample, discarding all material that passes the 150- μm (No. 100) sieve. Crush or grind the sample in small portions using a disk pulverizer, rotary mill (rotating-puck) device, or mortar and pestle. To minimize the production of material passing the 150- μm (No. 100) sieve, use several passes of the portion through the equipment, removing material passing the 300- μm (No. 50) sieve before regrinding the remainder. If the amount of material retained on the 150- μm (No. 100) sieve is less than 100 g after pulverizing the entire 300-g sample, discard the sample and pulverize a new 300-g sample (Note 3).

NOTE 3—An over-pulverized sample may not produce the correct chemical test results. A properly pulverized sample will have about 110 to 150 g of material remaining on the 150- μm (No. 100) sieve after washing.

6.4 To ensure that all material finer than the 150- μm sieve has been removed, wash the sample over a 150- μm sieve. Do not wash more than 100 g over a 203-mm diameter sieve at one time. Dry the washed sample at $105 \pm 5^\circ\text{C}$ for 20 ± 4 h. Cool the sample and again sieve on the 150- μm sieve. If inspection of the sample indicates the presence of silty or clayey coatings on particles, repeat the washing and drying procedure, and sieve as before over the 150- μm sieve. Reserve the portion retained on the 150- μm sieve for the test sample.

7. Reaction Procedure

7.1 Weigh out three representative 25.00 ± 0.05 -g portions of the dry 150- μm to 300- μm test sample prepared in accordance with Section 6. Place one portion in each of the three of the reaction containers, and add by means of a pipet, 25 mL of the 1.000 N NaOH solution. To a fourth reaction container, by means of a pipet, add 25 mL of the same NaOH solution to serve as a blank. Seal the four containers and gently swirl them to liberate trapped air.

7.2 Immediately after the containers have been sealed, place them in a liquid bath maintained at $80 \pm 1.0^\circ\text{C}$. After $24 \pm \frac{1}{4}$ h, remove the containers from the bath and cool them, for 15 ± 2 min, under running tap water having a temperature below 30°C .

7.3 Immediately after the containers have been cooled, open them and filter the solution from the aggregate residue. Use a porcelain Gooch crucible (see Note 4) with a disk of rapid, analytical-grade filter paper cut to fit the bottom of the crucible, setting the crucible in a rubber crucible holder in a funnel. Place a dry test tube, 35 to 50-mL capacity, in the filter flask to collect the filtrate, and seat the funnel in the neck of the filter flask. With the aspirator in operation or the vacuum line open, decant a small quantity of the solution onto the filter paper so it will seat properly in the crucible. Without stirring the contents of the container, decant the remaining free liquid into the crucible. When the decantation of the liquid has been completed, discontinue the vacuum and transfer the solids remaining in the container to the crucible and pack in place with the aid of a stainless-steel spatula. Then apply and adjust the vacuum to approximately 51 kPa. Continue the filtration until further filtration yields filtrate at the approximate rate of 1 drop every 10 s; reserve the filtrate for further tests. Record the total amount of time during which the vacuum is applied

as the filtration time; make every effort to achieve an equal filtration time for all samples in a set, by uniformity of procedure in the assembly of the filtration apparatus and the packing of the solids in the crucible.

NOTE 4—Coors Size No. 4 Gooch crucibles, or equivalent, have been found satisfactory for this purpose.

7.4 Filter the blank according to the procedure described in 7.3. Apply the vacuum for a length of time equal to the average filtration time for the three specimens.

7.5 Immediately following the completion of filtration, stir the filtrate to assure homogeneity, then take by pipet an aliquot of 10 mL of the filtrate and dilute with water to 200 mL in a volumetric flask. Reserve this diluted solution for the determination of the dissolved SiO_2 and the reduction in alkalinity.

7.6 If the diluted filtrate is not to be analyzed within 4 h following completion of the filtration, transfer the solution to a clean, dry polyethylene container and close the container by means of a stopper or tight-fitting cap or lid.

8. Dissolved Silica by the Gravimetric Method

8.1 Procedure:

8.1.1 Transfer by pipet 100 mL of the dilute solution (7.5) to an evaporating dish, preferably of platinum for speed in evaporation, add 5 to 10 mL of HCl (1.19 kg/L), and evaporate to dryness on a steam bath. Without heating the residue further, treat it with 5 to 10 mL of HCl (1.19 kg/L) and then an equal amount of water, or at once pour 10 to 20 mL of HCl (1 + 1) upon the residue. Cover the dish and digest for 10 min on the steam bath or a hot plate. Dilute the solution with an equal volume of hot water, filter immediately through quantitative-grade, low-ash filter paper, and wash the separated silica (SiO_2) thoroughly with hot water (see Note 5) and reserve the residue.

NOTE 5—The washing of the SiO_2 precipitates can be made more effective by using hot HCl (1 + 99) and then completing the washing with hot water.

8.1.2 Again evaporate the filtrate to dryness, baking the residue in an oven for 1 h at 105 to 110°C. Take up the residue with 10 to 15 mL of HCl (1 + 1) and heat on the bath or hot plate. Dilute the solution with an equal volume of hot water and catch and wash the small amount of SiO_2 it contains on another filter paper. This second evaporation is necessary only when determining the concentration of the standard sodium metasilicate solution in 5.10. For the other test solutions, it can be eliminated.

8.1.3 Transfer the papers containing the residue (8.1.1 and 8.1.2) to a platinum crucible (see Note 6). Dry and ignite the papers, first at a low heat until the carbon of the filter paper is completely consumed without inflaming, and finally at 1100 to 1200°C until the mass remains constant.

NOTE 6—The mass of the empty crucible may be determined if one wishes to know the magnitude of impurities in the residue of SiO_2 .

8.1.4 Treat the SiO_2 thus obtained, which will contain small amounts of impurities, in the crucible with a few drops of water, about 10 mL of HF, and one drop of H_2SO_4 , and evaporate cautiously to dryness on the steam bath. Finally, heat the small residue at 1050 to 1100°C for 1 to 2 min, cool, and determine the mass. The difference between this determination and that previously obtained represents the amount of SiO_2 .

8.2 Calculation:

8.2.1 Calculate the SiO_2 concentration of the NaOH solution filtered from the aggregate material, as follows:

$$S_c = 3330 \times W \quad (1)$$

where:

S_c = concentration of SiO_2 in mmol/L in the original filtrate, and

W = grams of SiO_2 found in 100 mL of the dilute solution.

9. Dissolved Silica by the Photometric Method

9.1 Application:

9.1.1 This method is applicable to the determination of crystalloidal (noncolloidal) silica (see Note 7) in all aqueous solutions except those with excessive color interferences (~~tannin, etc.~~), (tannin and so forth), but it will not determine total silica. The method is particularly applicable to rapid control analysis of crystalloidal silica below 10 ppm.

NOTE 7—Crystalloidal (noncolloidal) silica reacts with molybdate ion in acid solution (optimum pH 1.2 to 1.5) to form a greenish yellow silico-molybdate color complex the intensity of which is approximately proportional to the silica concentration of the solution, but does not follow Beer's law perfectly.

10. Preparation of Calibration Curve

10.1 Prepare a series of solutions of known silica concentration varying from 0.0 to 0.5 mmol/L by diluting portions of the stock solution of sodium silicate (5.10). Transfer the portions of sodium silicate solution to 100-mL volumetric flasks about half filled with water.

10.2 Add 2 mL of the ammonium molybdate solution and 1 mL of HCl (1 + 1), and agitate by swirling the flask. Allow the solution to stand for 15 min at room temperature. Add 1.5 ± 0.2 mL of the oxalic acid solution, fill the flask to the mark with water, and mix thoroughly. Allow the solution to stand for 5.0 ± 0.1 min. Read the transmittance of the various solutions on the

photometer at 410 nm, in comparison with that of water.

10.3 Prepare a calibration curve by plotting the percent transmittance or absorbance readings against the known concentrations of silica in each solution.

11. Determination of Dissolved Silica

11.1 Transfer by pipet a 10-mL aliquot of the dilute solution to a 100-mL volumetric flask half filled with water and proceed as directed in 10.2 and 10.3. Read the concentration of silica in the solution directly from the previously prepared calibration curve correlating transmission of light of this wave length with silica concentration. If the transmittance is below 30 % or above 50 %, a smaller or larger aliquot of the diluted solution shall be used.

12. Calculation

12.1 Calculate the SiO₂ concentration of the NaOH solution filtered from the aggregate material, as follows:

$$S_c = 20 \times (100/V) \times C \quad (2)$$

where:

S_c = concentration of SiO₂, mmol/L in the original filtrate,

C = concentration of silica in the solution measured in the photometer, mmol/L, and

V = millilitres of dilute solution used from 7.5.

13. Reduction in Alkalinity

13.1 *Procedure:*

13.1.1 Transfer by pipet a 20-mL aliquot of the dilute solution (7.5) to a 125-mL Erlenmeyer flask, add 2 or 3 drops of phenolphthalein solution, and titrate with 0.05-N HCl to the phenolphthalein end point.

13.2 *Calculation:*

13.2.1 Calculate the reduction in alkalinity as follows:

$$R_c = (20N/V_1)(V_3 - V_2) \times 1000 \quad (3)$$

where:

R_c = the reduction in alkalinity, mmol/L,

N = normality of the HCl used for the titration,

V_1 = millilitres of dilute solution used from 7.5,

V_2 = millilitres of HCl used to attain the phenolphthalein end point in the test sample, and

V_3 = millilitres of HCl used to attain the phenolphthalein end point in the blank.

14. Precision and Bias

14.1 *Precision*—Information concerning the precision of this test method is being investigated and will be published when the proper data have been obtained and analyzed as prescribed in Practice C 670.

14.2 Preliminary data on precision indicate that the test results may be considered satisfactory if none of the three values of R_c (and of S_c) differs from the average of the three by more than the following amounts: (1) when the average is 100 mmol or less, 12 mmol/L, and (2) when the average is more than 100 mmol/L, 12 %.

14.3 *Bias*—Since there is no accepted reference material suitable for determining the bias of this test method, no statement on bias is made.

15. Keywords

15.1 aggregate reactivity; alkali; alkali-silica reactivity; concrete aggregates

APPENDIX**(Nonmandatory Information)****X1. INTERPRETATION OF RESULTS**

X1.1 Correlations between data obtained by this method, expansion of mortar bars containing high-alkali cement, petrographic examinations of aggregates, and performance of aggregates in concrete structures have been published (1-7).⁹ On the basis of these data, the solid curve shown in Fig. X1.1 has been established. A potentially deleterious degree of alkali reactivity is indicated if any of the three R_c , S_c points lie on the deleterious side of the curve in Fig. X1.1. However, potentially deleterious aggregates represented by points lying above the dashed line in Fig. X1.1 may give relatively low expansions in mortar or concrete even though they are extremely reactive with alkalis. These aggregates should be considered to indicate a potentially deleterious degree of reactivity until the innocuous character of the aggregate is demonstrated by service records or by supplementary tests in accordance with the provisions of Test Method C 227, using several mixtures of the test aggregate and an essentially inert aggregate such as properly graded unstrained quartz C 1260, or chert-free limestone, C 1293, as applicable. The mixtures additional test method(s) should represent a series be selected based on the mineralogical characteristics of proportions of the test aggregate and essentially inert aggregate ranging from about 5:95 to 50:50 by mass. aggregate. It is recommended that these mineralogical properties be determined with a petrographic examination in accordance with the provisions of Guide C 295.

X1.2 Results of ~~the this~~ test may not be correct for aggregates containing carbonates of calcium, magnesium, or ferrous iron, such as calcite, dolomite, magnesite, or siderite; or silicates of magnesium such as antigorite (serpentine) (6,7). The error introduced by calcium carbonate is not significant unless S_c and R_c values indicate the potential reactivity is marginal. Examinations of the aggregate in accordance with Guide C 295, can be used to determine the presence of minerals of this type. ~~In order to evaluate these possible effects, testing in accordance with Test Method C 227 is recommended. type.~~

X1.3 It is recommended that interpretations based upon this method be correlated with Guide C 295 and service records of the aggregate. The results of this test do not predict the late-slow silica-silicate reactivity in concrete that may result with aggregates containing strained or micro-granulated quartz, or aggregates composed of metagraywacke, meta-siltstone, meta-quartz, and similar rocks.

⁹ The boldface numbers in parentheses refer to the references appearing at the end of this test method.

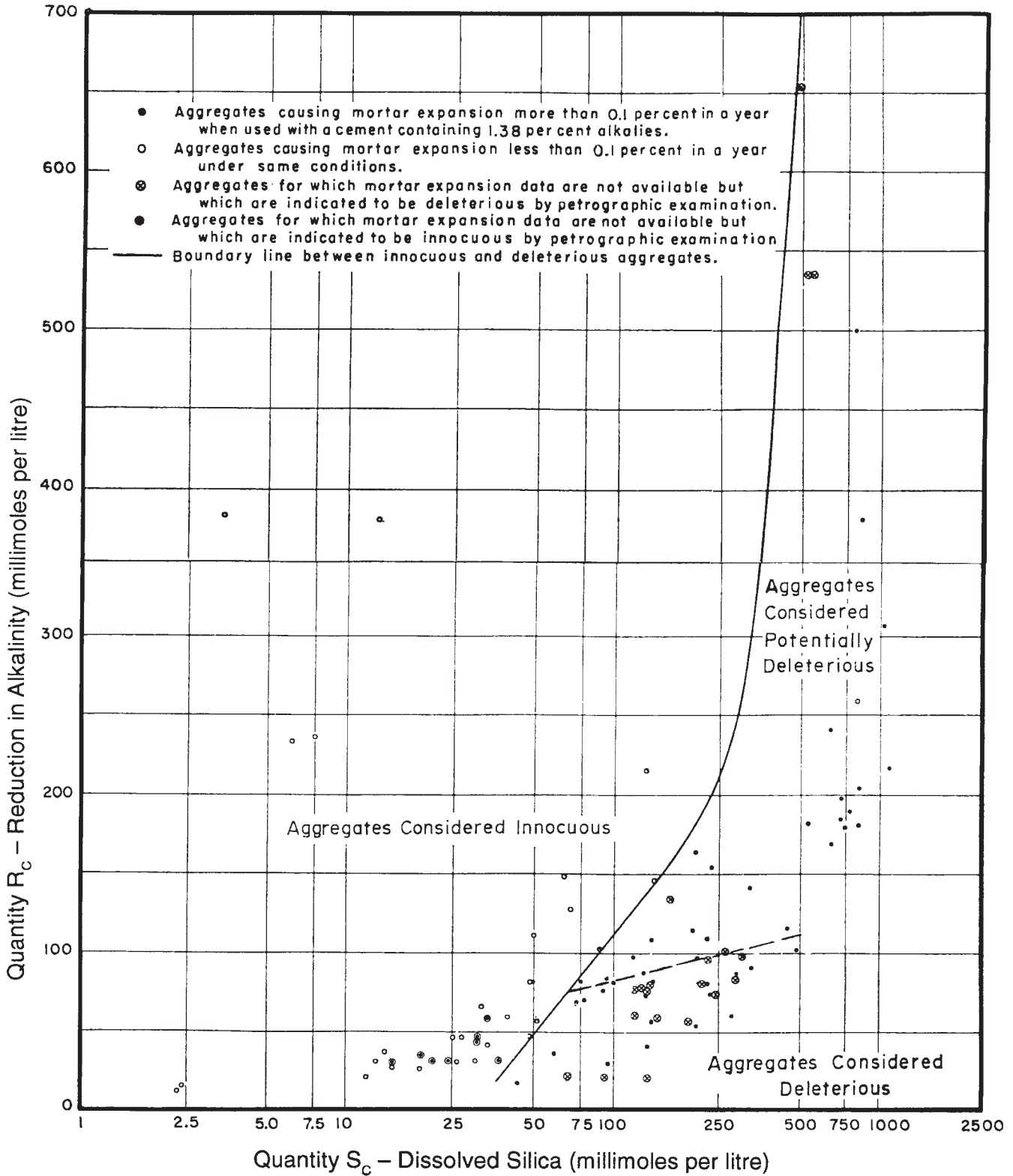

FIG. X1.1 Illustration of Division Between Innocuous and Deleterious Aggregates on Basis of Reduction in Alkalinity Test

REFERENCES

- (1) Mielenz, R. C., and Witte, L. P., “Tests Used by the Bureau of Reclamation for Identifying Reactive Concrete Aggregates,” *Proceedings*, ASTM, Vol 48, 1948, pp. 1071–1103 and discussion, p. 1104.
- (2) Mielenz, R. C., Greene, K. T., and Benton, E. J., “Chemical Test for Reactivity of Aggregates with Cement Alkalies: Chemical Processes in Cement-Aggregate Reaction,” *Proceedings*, Am. Concrete Inst., Vol 44, 1948, p. 193.
- (3) Lerch, William, “Studies of Some Methods of Avoiding Expansion and Pattern Cracking Associated with the Alkali-Aggregate Reaction,” *Symposium on Use of Pozzolanic Materials in Mortars and Concretes*, ASTM STP 99, ASTM, 1950, p. 153.
- (4) Slate, F. O., “Chemical Reactions of Indiana Aggregates in Disintegration of Concrete,” *Proceedings*, ASTM, Vol 49, 1949, p. 954.
- (5) Lerch, William, “Chemical Reactions of Concrete Aggregates,” *ASTM STP 169*, ASTM, 1956, p. 334.
- (6) Mielenz, R. C., and Benton, E. J., “Evaluation of the Quick Chemical Test for Alkali Reactivity of Concrete Aggregate,” *Bulletin 171*, Highway Research Board, 1958, p. 1.
- (7) Chaiken, Bernard, and Halstead, W. J., “Correlation Between Chemical and Mortar Bar Tests for Potential Alkali Reactivity of Concrete Aggregates,” *Public Roads*, Vol 30, 1959, p. 177.

SUMMARY OF CHANGES

This section identifies

Committee C09 has identified the location of selected changes to this standard since the last issue (C 289 – 02) that may impact the use of this standard. (Approved Aug. 10, 2003.)

- (1) Added Test Methods C 1260 and C 1293 to Section 2.1.
- (2) Revised Section 3, adding paragraph 3.3.
- (3) Revised sections X1.1 and X1.2.

Committee C09 has identified the location of selected changes to this standard since the last issue, (C 289 – 01) that may impact the use of this standard. (Approved July 10, 2002.)

- (1) Paragraph 6.2 has been revised.
- (2) New paragraphs 6.2.1, 6.2.2, and 6.2.3 were added.
- (3) Practices C 702 and D 75 were added to Section 2.
- (4) Paragraph 4.3 has been revised.
- (5) Paragraph 4.4 has been revised into paragraphs 4.4.1 and 4.4.2.
- (6) Former paragraph 6.2 has been relocated to become paragraph 6.3, and the former paragraph 6.3 has been relocated to become paragraph 6.4.

ASTM International takes no position respecting the validity of any patent rights asserted in connection with any item mentioned in this standard. Users of this standard are expressly advised that determination of the validity of any such patent rights, and the risk of infringement of such rights, are entirely their own responsibility.

This standard is subject to revision at any time by the responsible technical committee and must be reviewed every five years and if not revised, either reapproved or withdrawn. Your comments are invited either for revision of this standard or for additional standards and should be addressed to ASTM International Headquarters. Your comments will receive careful consideration at a meeting of the responsible technical committee, which you may attend. If you feel that your comments have not received a fair hearing you should make your views known to the ASTM Committee on Standards, at the address shown below.

This standard is copyrighted by ASTM International, 100 Barr Harbor Drive, PO Box C700, West Conshohocken, PA 19428-2959, United States. Individual reprints (single or multiple copies) of this standard may be obtained by contacting ASTM at the above address or at 610-832-9585 (phone), 610-832-9555 (fax), or service@astm.org (e-mail); or through the ASTM website (www.astm.org).