



## Standard Test Method for Flexural Strength of Concrete (Using Simple Beam With Center-Point Loading)<sup>1</sup>

This standard is issued under the fixed designation C 293; the number immediately following the designation indicates the year of original adoption or, in the case of revision, the year of last revision. A number in parentheses indicates the year of last reapproval. A superscript epsilon ( $\epsilon$ ) indicates an editorial change since the last revision or reapproval.

*This standard has been approved for use by agencies of the Department of Defense.*

### 1. Scope

1.1 This test method covers determination of the flexural strength of concrete specimens by the use of a simple beam with center-point loading. It is not an alternative to Test Method C 78.

1.2 The values stated in inch-pound units are to be regarded as standard. The SI equivalent of inch-pound units has been rounded where necessary for practical application.

1.3 *This standard does not purport to address all of the safety concerns, if any, associated with its use. It is the responsibility of the user of this standard to establish appropriate safety and health practices and determine the applicability of regulatory limitations prior to use.*

### 2. Referenced Documents

#### 2.1 ASTM Standards:

C 31 Practice for Making and Curing Concrete Test Specimens in the Field<sup>2</sup>

C 78 Test Method for Flexural Strength of Concrete (Using Simple Beam with Third Point Loading)<sup>2</sup>

C 192 Practice for Making and Curing Concrete Test Specimens in the Laboratory<sup>2</sup>

C 617 Practice for Capping Cylindrical Concrete Specimens<sup>2</sup>

C 1077 Practice for Laboratories Testing Concrete and Concrete Aggregates for Use in Construction and Criteria for Laboratory Evaluation<sup>2</sup>

E 4 Practices for Force Verification of Testing Machines<sup>3</sup>

### 3. Significance and Use

3.1 This test method is used to determine the modulus of rupture of specimens prepared and cured in accordance with Practices C 31 or C 192. The strength determined will vary where there are differences in specimen size, preparation, moisture condition, or curing.

3.2 The results of this test method may be used to determine

compliance with specifications or as a basis for proportioning, mixing and placement operations. This test method produces values of flexural strength significantly higher than Test Method C 78 (Note 1).

NOTE 1—The testing laboratory performing this test method may be evaluated in accordance with Practice C 1077.

### 4. Apparatus

4.1 The testing machine shall conform to the requirements of the sections on Basis of Verification, Corrections, and Time Interval Between Verifications of Practices E 4. Hand operated testing machines having pumps that do not provide a continuous loading to failure in one stroke are not permitted. Motorized pumps or hand operated positive displacement pumps having sufficient volume in one continuous stroke to complete a test without requiring replenishment are permitted and shall be capable of applying loads at a uniform rate without shock or interruption.

4.2 *Loading Apparatus*—The mechanism by which forces are applied to the specimen shall employ a load-applying block and two specimen support blocks. It shall ensure that all forces are applied perpendicular to the face of the specimen without eccentricity. A diagram of an apparatus that accomplishes this purpose is shown in Fig. 1.

4.2.1 All apparatus for making center-point loading flexure tests shall be similar to Fig. 1 and maintain the span length and central position of the load-applying block with respect to the support blocks constant within  $\pm 0.05$  in. ( $\pm 1.3$  mm).

4.2.2 Reactions shall be parallel to the direction of the applied load at all times during the test, and the ratio of the horizontal distance between the point of load application and nearest reaction to the depth of the beam shall be  $1.5 \pm 2\%$ .

4.2.3 The load-applying and support blocks shall not be more than  $2\frac{1}{2}$  in. (64 mm) high, measured from the center or the axis of pivot, and shall extend at least across the full width of the specimen. Each hardened bearing surface in contact with the specimen shall not depart from a plane by more than 0.002 in. (0.05 mm) and shall be a portion of a cylinder, the axis of which is coincidental with either the axis of the rod or center of the ball, whichever the block is pivoted upon. The angle subtended by the curved surface of each block shall be at least  $45^\circ$  (0.79 rad). The load-applying and support blocks shall be maintained in a vertical position and in contact with the rod or

<sup>1</sup> This test method is under the jurisdiction of ASTM Committee C-9 on Concrete and Concrete Aggregates and is the direct responsibility of Subcommittee C09.61 on Testing Concrete for Strength.

Current edition approved April 15, 1994. Published June 1994. Originally published as C 293 – 52 T. Last previous edition C 293 – 79.

<sup>2</sup> *Annual Book of ASTM Standards*, Vol 04.02.

<sup>3</sup> *Annual Book of ASTM Standards*, Vol 03.01.

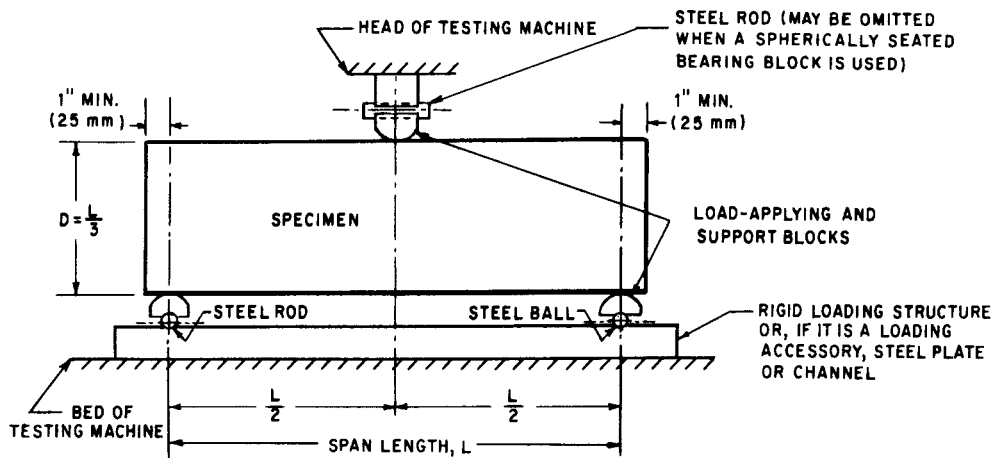

NOTE 1—Apparatus may be used inverted.

FIG. 1 Diagrammatic View of a Suitable Apparatus for Flexure Test of Concrete by Center-Point Loading Method.

ball by means of spring-loaded screws that hold them in contact with the pivot rod or ball. The rod in the center load-applying block in Fig. 1 may be omitted when a spherically seated bearing block is used.

### 5. Test Specimen

5.1 The test specimen shall conform to all requirements of Practice C 31 or C 192 applicable to beam and prism specimens and shall have a test span within 2 % of being three times its depth as tested. The sides of the specimen shall be at right angles with the top and bottom. All surfaces shall be smooth and free of scars, indentations, holes, or inscribed identification marks.

### 6. Procedure

6.1 Flexural tests of moist-cured specimens shall be made as soon as practical after removal from moist storage. Surface drying of the specimen results in a reduction in the measured modulus of rupture.

6.2 Turn the test specimen on its side with respect to its position as molded and center it on the support blocks. Center the loading system in relation to the applied force. Bring the load-applying block in contact with the surface of the specimen at the center and apply a load of between 3 and 6 % of the estimated ultimate load. Using 0.004 in. (0.10 mm) and 0.015 in. (0.38 mm) leaf-type feeler gages, determine whether any gap between the specimen and the load-applying or support blocks is greater or less than each of the gages over a length of 1 in. (25 mm) or more. Grind, cap, or use leather shims on the specimen contact surface to eliminate any gap in excess of 0.004 in. (0.10 mm). Leather shims shall be of uniform 1/4 in. (6.4 mm) thickness, 1 to 2 in. (25 to 50 mm) in width, and shall extend across the full width of the specimen. Gaps in excess of 0.015 in. (0.38 mm) shall be eliminated only by capping or grinding. Grinding of lateral surfaces shall be minimized inasmuch as grinding may change the physical characteristics of the specimens. Capping shall be in accordance with Practice C 617.

6.3 Load the specimen continuously and without shock. The load shall be applied at a constant rate to the breaking point.

Apply the load at such a rate that constantly increases the extreme fiber stress between 125 and 175 psi/min (0.86 and 1.21 MPa/min), when calculated in accordance with 7.1, until rupture occurs.

### 7. Measurement of Specimens After Test

7.1 Take three measurements across each dimension (one at each edge and at the center) to the nearest 0.05 in. (1 mm) to determine the average width and average depth of the specimen at the point of fracture. If fracture occurs at a capped section, include the cap thickness in measurement.

### 8. Calculation

8.1 Calculate the modulus of rupture as follows:

$$R = 3 PL/2bd^2 \quad (1)$$

where:

$R$  = modulus of rupture, psi, or MPa,

$P$  = maximum applied load indicated by the testing machine, lbf, or N,

$L$  = span length, in., or mm,

$b$  = average width of specimen, at the fracture, in., or mm, and

$d$  = average depth of specimen, at the fracture, in., or mm.

NOTE 2—The weight of the beam is not included in the above calculation.

### 9. Report

9.1 Report the following information:

9.1.1 Identification number,

9.1.2 Average width to the nearest 0.05 in. (1 mm), at the fracture,

9.1.3 Average depth to the nearest 0.05 in. (1 mm), at the fracture,

9.1.4 Span length in inches (or millimetres),

9.1.5 Maximum applied load in pounds-force (or newtons),

9.1.6 Modulus of rupture calculated to the nearest 5 psi (0.05 MPa),

9.1.7 Record of curing and apparent moisture condition of the specimens at the time of test,

9.1.8 If specimens were capped, ground, or if leather shims were used,

9.1.9 Defects in specimens, and

9.1.10 Age of specimens.

## 10. Precision and Bias

10.1 *Precision*—The coefficient of variation of test results has been observed to be dependent on the strength level of the

beams.<sup>4</sup> The single operator coefficient of variation has been found to be 4.4 %. Therefore, results of two properly conducted tests by the same operator on beams made from the same batch sample should not differ from each other by more than 12 %. The multilaboratory coefficient of variation has been found to be 5.3 %. Therefore, results of two different laboratories on beams made from the same batch sample should not differ from each other by more than 15 %.

10.2 *Bias*—Since there is no accepted standard for determining bias in this test method, no statement on bias is made.

## 11. Keywords

11.1 beams; concrete; flexural strength testing; modulus of rupture

---

<sup>4</sup> See “Improved Concrete Quality Control Procedures Using Third Point Loading” by P. M. Carrasquillo and R. L. Carrasquillo, Research Report 119-1F, Project 3-9-87-1119, Center For Transportation Research, The University of Texas at Austin, November 1987, for information as to the relationship of strength and variability under center point loading.

*The American Society for Testing and Materials takes no position respecting the validity of any patent rights asserted in connection with any item mentioned in this standard. Users of this standard are expressly advised that determination of the validity of any such patent rights, and the risk of infringement of such rights, are entirely their own responsibility.*

*This standard is subject to revision at any time by the responsible technical committee and must be reviewed every five years and if not revised, either reapproved or withdrawn. Your comments are invited either for revision of this standard or for additional standards and should be addressed to ASTM Headquarters. Your comments will receive careful consideration at a meeting of the responsible technical committee, which you may attend. If you feel that your comments have not received a fair hearing you should make your views known to the ASTM Committee on Standards, 100 Barr Harbor Drive, West Conshohocken, PA 19428.*

*This standard is copyrighted by ASTM, 100 Barr Harbor Drive, West Conshohocken, PA 19428-2959, United States. Individual reprints (single or multiple copies) of this standard may be obtained by contacting ASTM at the above address or at 610-832-9585 (phone), 610-832-9555 (fax), or service@astm.org (e-mail); or through the ASTM website (<http://www.astm.org>).*