



Designation: C- 418 – 908

## Standard Test Method for Abrasion Resistance of Concrete by Sandblasting<sup>1</sup>

This standard is issued under the fixed designation C 418; the number immediately following the designation indicates the year of original adoption or, in the case of revision, the year of last revision. A number in parentheses indicates the year of last reapproval. A superscript epsilon ( $\epsilon$ ) indicates an editorial change since the last revision or reapproval.

*This standard has been approved for use by agencies of the Department of Defense.*

### 1. Scope

1.1 This test method covers determination of the abrasion resistance characteristics of concrete by subjecting it to the impingement of air-driven silica sand. It is intended for use as a basis for the development of informed judgment.

1.2 The values stated in SI units are to be regarded as the ~~standard except where inch-pound standard.~~ Inch-pound units are given first followed by SI units shown for information purposes in parentheses.

1.3 *This standard does not purport to address the safety ~~problems~~ concerns, if any, associated with its use. It is the responsibility of the user of this standard to establish appropriate safety and health practices and determine the applicability of regulatory limitations prior to use.*

NOTE 1—Users of this test method are advised that there are known safety hazards associated with the use of silica as a blasting media. Consult the silica manufactures MSDS to insure that the latest recommended health and safety practices are being followed.

NOTE 2—Other procedures are available for measuring abrasion resistance of concrete surfaces in addition to subjecting it to air driven silica sand. Consideration should be given to other methods of testing as outlined in ASTM C 779, ASTM C 944, and ~~C 944, ASTM C 1138.~~ The test method most closely representing service conditions should be used.

1.4 The text of this standard references notes and footnotes which are provided as explanatory material. These notes and footnotes (excluding those in tables and figures) shall not be considered as requirements of this standard.

### 2. Referenced Documents

#### 2.1 ASTM Standards:

~~C-670 Practice 778 Specification for Preparing Precision and Bias Statements for Test Methods for Construction Materials Standard Sand<sup>2</sup>~~

<sup>1</sup> This test method is under the jurisdiction of ASTM Committee C-9 on Concrete and Concrete Aggregates and is the direct responsibility of Subcommittee C09.62 on Abrasion Testing of Concrete.

Current edition approved ~~Oct. 26, 1990; May 10, 1998.~~ Published ~~December 1990; March 1999.~~ Originally published as C 418 – 58 T. Last previous edition C 418 – 8 90.

~~C-778 Specification 779 Test Method for Standard Sand Abrasion Resistance of Horizontal Concrete Surfaces<sup>3</sup>~~  
~~C 77944 Test Method for Abrasion Resistance of Horizontal Concrete or Mortar Surfaces by the Rotating-Cutter Method<sup>3</sup>~~  
~~C-944 Test 1138 Test Method for Abrasion Resistance of Concrete or Mortar Surfaces by the Rotating-Cutter Method<sup>2</sup>~~  
~~E 18 Test Methods for Rockwell Hardness and Rockwell Superficial Hardness of Metallic Materials<sup>4</sup> (Underwater Method)<sup>3</sup>~~

### 3. Significance and Use

3.1 This test method covers the laboratory evaluation of the relative resistance of concrete surfaces to abrasion. This procedure simulates the action of waterborne abrasives and abrasives under traffic on concrete surfaces. It performs a cutting action which tends to abrade more severely the less resistant components of the concrete. Adjustments in the pressure used and the type of abrasive permit a variation in the severity of abrasion which may be used to simulate other types of wear.

### 4. Apparatus

4.1 *Scales*—The scale shall have a capacity of 5000 g or more. The permissible variation at a load of 5000 g (11 lb) shall be  $\pm 5$  g (0.2 oz).

4.2 *Weights*—The permissible variations on weights used in weighing shall be as prescribed in Table 1. The permissible variations on new weights shall be one half of the values given in Table 1.

4.3 *Sand Blast Apparatus*—The sand blast apparatus shall consist of an injector-type gun. The gun shall have a high-velocity air jet fed by a suitably controlled rate of flow for the abrasive material. The nozzle shown in Fig. 1 shall consist of cold-rolled bar stock, ~~1½ in. (38 mm)~~ 40 mm (1.5 in.) long, or hardened tool steel HRC  $48 \pm 2$  as determined by Test Methods E 18, drilled to ~~0.250  $\pm$  0.001 in. (6.35  $\pm$  0.02 mm)~~ 6.40  $\pm$  0.02 mm (0.250  $\pm$  0.001 in.) approximately 700 kPa (100 psi) through the center. The walls of the nozzle shall have a 45° bevel on the inside at the upper end. A compressed air supply of approximately 100 psi (690 kPa) shall be available and equipped with a pressure-control device. Provision shall be made to collect the spent abrasive and dust. Suitable jigs and clamps shall be provided to hold the test specimen in a fixed position with relation to the discharge end of the nozzle. For laboratory wear testing of concrete specimens a commercial sand blast cabinet may be selected similar to that shown in Fig. 2.<sup>4</sup>

<sup>2</sup> *Annual Book of ASTM Standards*, Vol 04.021.

<sup>3</sup> *Annual Book of ASTM Standards*, Vol 04.042.

~~*Annual Book of ASTM Standards*, Vol 03.01.~~

<sup>4</sup> A sand blast cabinet is available from CLEMCO Industries, 2177 Jerrold Ave., San Francisco, CA 94124.

**TABLE 1 Permissible Variations on Weights**

Weight, g	Permissible Variations on Weights in Use, g
1000	$\pm 0.50$
500	$\pm 0.35$
300	$\pm 0.30$
250	$\pm 0.25$
200	$\pm 0.20$

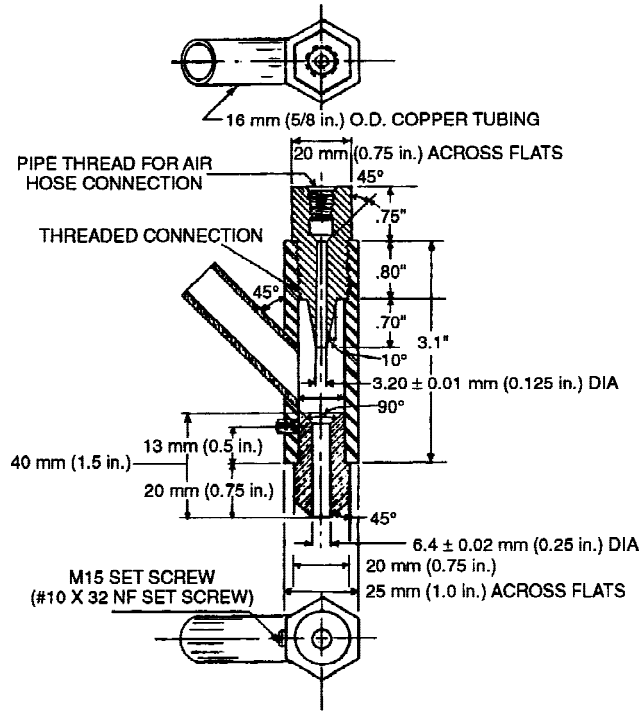

NOZZLE—All dimensions are approximate except where tolerances are shown. Inch-pound dimensions shown here for clarity purposes only.

FIG. 1 Gun Nozzle Assembly

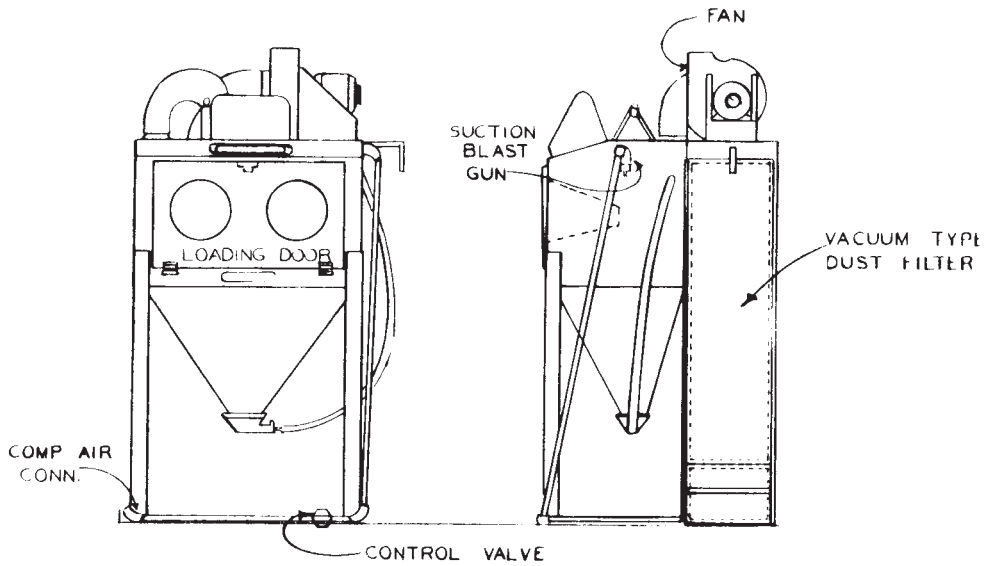

FIG. 2 Sand Blast Cabinet

4.4 *Shield*—The metal shield shall be square or circular, 150 mm (6 in.) on a side or diameter, made from 14 to 20 gage (1.90 to 0.91 mm) galvanized zinc-coated steel sheet or similar stock at least 6 in. (152 mm) square or in diameter if circular equivalent, having a thickness in the range of 0.90 to 1.90 mm (0.035 to 0.075 in.). The shield shall have an opening 1.13 ± 0.01 in. (28.70 ± 0.25 mm) 28.70 ± 0.25 mm (1.13 ± 0.01 in.) in diameter in the center. Opening 1.13 in. (28.7 mm) in diameter center.

NOTE 3—Opening of 28.7 mm (1.13 in.) is equivalent to 1 in.<sup>2</sup> or 6.45 sq cm<sup>2</sup>. Suitable clamps shall be provided to hold the shield fixed on the test specimen during the test. (1 in. sq).

4.5 *Abrasive*—The abrasive shall conform to Specification C 778 and be graded to pass a 850-µm (No. 20) sieve and retained on a 600-µm (No. 30) sieve.

## 5. Preparation of Specimens

5.1 Immerse the specimens in water for 24 h and then surface dry with a damp cloth to obtain a saturated, surface-dry condition at the time of test.

## 6. Calibration of Apparatus

6.1 Adjust the air pressure to  $4140 \pm 1$  kPa ( ~~$60 \pm 1$~~  ( $59.5 \pm 1$  psi)) and collect the abrasive for a period of 1 min. Adjust the rate of flow of abrasive to  $600 \pm 25$  g/min.

6.2 The abrasive shall be regraded or replaced after every 60 min of operating time in order to maintain a uniform grading.

6.3 A cold-rolled steel nozzle shall be replaced every 60 min of operating time. A hardened tool steel nozzle shall be changed as required to maintain the original uniform flow and original blast pattern.

## 7. Procedure

7.1 Place the specimen with the surface to be tested normal to the nozzle axis and at a distance of  $3 \pm 0.1$  in. ( $76 \pm 2.5$  mm)  $75 \pm 25$  mm ( $3.0 \pm 0.1$  in.) from the end. Clamp the specimen, with shield attached, firmly in place. Expose the surface to the blast for a period of 1 min. Repeat this on at least eight different spots on the surface. Determine the abraded volume by filling the abrasion cavities with an oil base modeling clay. Press the clay into the cavities manually with a moderate amount of finger pressure and level flush with a straight edge. ~~Weigh~~ Determine the mass of the clay supply before and after the cavities are filled instead of removing the clay from the filled cavities. Repeat filling with clay at least once on each specimen to ensure reproducible results.

## 8. Calculation

8.1 Calculate the ~~weight~~ mass of clay,  $W_c$ , as follows:

$$W_c = W_i - W_f$$

where:

$W_i$  = ~~weight~~ mass, initial supply, and

$W_f$  = ~~weight~~ mass, final supply.

8.2 Calculate the specific gravity of clay,  $D$ , as follows:

~~$$D = B / (B - C)$$~~

$$D = B / (B - C)$$

where:

$B$  = ~~weight~~ mass of clay in air, g, and

$C$  = ~~weight~~ mass of clay in water, g.

8.3 Calculate the volume of clay,  $V$ , per cavity in cubic centimetres, as follows:

~~$$V = W/D$$~~

$$V = W / D$$

where:

$W$  = ~~weight~~ mass of clay in cavity, and

$D$  = specific gravity of clay.

8.4 Calculate the abrasion coefficient loss on a volumetric basis, expressed in cubic centimetres per square centimetre, in order to compensate for variable densities of specimens, as follows:

$$A_c = V / A$$

where:

$A_c$  = abrasion coefficient, cubic centimetres per square centimetre, and

$A$  = area of surface abraded, square centimetres.

## 9. Report

9.1 Report the following information:

9.2 Report the abrasion coefficient loss to the nearest  $0.01 \text{ cm}^3/\text{cm}^2$ .

9.3 Report the location of the concrete where the specimen was obtained and other characteristics of the concrete, if known.

## 10. Precision and Bias

10.1 On a limited sampling (Note ~~2~~; 4), the single-operator coefficient of variation has been found to be 9.1 %.<sup>5</sup> Therefore, results of two properly conducted tests by the same operator on the same material using the same equipment should not differ by more than 25.8 %<sup>5</sup> of their average.

<sup>5</sup>A sand blast cabinet is available from CLEMCO Industries, 2177 Jerrold Ave., San Francisco, CA 94124.

10.2 On a limited sampling (Note-2), 4), the multi-operator coefficient of variation has been found to be 10.3 %.<sup>4</sup> Therefore, results of two properly conducted tests by two operators on the same material using the same equipment should not differ from each other by more than 29.1 %<sup>5</sup> of their average.

NOTE 24—The data, on file at ASTM Headquarters, ~~and expected to be published~~ involve two operators performing the tests on samples made from the same batch and repeated on another day. Two concrete mixtures having different expected abrasion resistance were also used. The tests were conducted in one laboratory using the same equipment. As more laboratories become more equipped and capable of performing the test, a more detailed interlaboratory test program will be conducted.

10.3 Since there is no acceptable reference material suitable for determining bias for the procedure in this test method, no statement of bias is being made.

---

<sup>5</sup> These numbers represent, respectively, the (1s %) and (d2s %) limits as described in Practice C 670 for Preparing Precision and Bias Statements for Test Methods for Construction Materials.

*ASTM International takes no position respecting the validity of any patent rights asserted in connection with any item mentioned in this standard. Users of this standard are expressly advised that determination of the validity of any such patent rights, and the risk of infringement of such rights, are entirely their own responsibility.*

*This standard is subject to revision at any time by the responsible technical committee and must be reviewed every five years and if not revised, either reapproved or withdrawn. Your comments are invited either for revision of this standard or for additional standards and should be addressed to ASTM International Headquarters. Your comments will receive careful consideration at a meeting of the responsible technical committee, which you may attend. If you feel that your comments have not received a fair hearing you should make your views known to the ASTM Committee on Standards, at the address shown below.*

*This standard is copyrighted by ASTM International, 100 Barr Harbor Drive, PO Box C700, West Conshohocken, PA 19428-2959, United States. Individual reprints (single or multiple copies) of this standard may be obtained by contacting ASTM at the above address or at 610-832-9585 (phone), 610-832-9555 (fax), or service@astm.org (e-mail); or through the ASTM website (www.astm.org).*