



Designation: **C 779/C 779M – 9500**

Standard Test Method for Abrasion Resistance of Horizontal Concrete Surfaces¹

This standard is issued under the fixed designation C 779/C 779M; the number immediately following the designation indicates the year of original adoption or, in the case of revision, the year of last revision. A number in parentheses indicates the year of last reapproval. A superscript epsilon (ε) indicates an editorial change since the last revision or reapproval.

1. Scope

1.1 This test method covers three procedures for determining the relative abrasion resistance of horizontal concrete surfaces. The procedures differ in the type and degree of abrasive force they impart, and are intended for use in determining variations in surface properties of concrete affected by mixture proportions, finishing, and surface treatment. They are not intended to provide a quantitative measurement of the length of service that may be expected from a specific surface.

1.2 The values stated in SI units or inch-pound units are to be regarded separately as standard. Within the-s text, the inch-pound units are shown in brackets. The values stated in each system are not exact equivalents; therefore, each system shall be used independently of each other.

1.3 *This standard does not purport to address all of the safety concerns, if any, associated with its use. It is the responsibility of the user of this standard to establish appropriate safety and health practices and determine the applicability of regulatory limitations prior to use.*

NOTE 1—Other procedures are available for measuring the abrasion resistance of concrete surfaces in addition to the three procedures contained in this test method. Consideration should be given to Test Methods C 944 and C 418. The test method most closely representing service conditions should be used.

2. Referenced Documents

2.1 ASTM Standards:

¹ This test method is under the jurisdiction of ASTM Committee ~~C-9~~ C09 on Concrete and Concrete Aggregates and is the direct responsibility of Subcommittee C09.62 on Abrasion Testing of Concrete.

Current edition approved ~~Oct. 10, 1995~~, 2000. Published ~~March 1996~~, August 2000. Originally published as C 779 – 74. Last previous edition ~~C 779 – 89a¹~~, C 779 – 95.

- C 418 Test Method for Abrasion Resistance of Concrete by Sandblasting²
- C 670 Practice for Preparing Precision and Bias Statements for Test Methods for Construction Materials²
- C 944 Test Method for Abrasion Resistance of Concrete or Mortar Surfaces by the Rotating-Cutter Method²

3. Significance and Use

3.1 The three test methods provide simulated abrasion conditions, which can be used to evaluate the effects on abrasion resistance of concrete, concrete materials, and curing or finishing procedures. They may also be used for quality acceptance of products and surface exposed to wear. They are not intended to provide a quantitative measurement of length of service.

3.2 The equipment used by each of these procedures is portable and thus suitable for either laboratory or field testing. The three procedures determine the relative wear of concrete surfaces as follows:

- 3.2.1 *Procedure A*—The revolving-disk machine operates by sliding and scuffing of steel disks in conjunction with abrasive grit.
- 3.2.2 *Procedure B*—The dressing-wheel machine operates by impact and sliding friction of steel dressing wheels.
- 3.2.3 *Procedure C*—The ball-bearing machine operates by high-contact stresses, impact, and sliding friction from steel balls.

NOTE 2—Diagrams of three machines meeting these specifications are shown in Fig. 1, Fig. 2, and Fig. 3.³

PROCEDURE A—REVOLVING DISKS

4. Apparatus

4.1 The function of the apparatus is dependent upon the abrasive action of the flat faces of three 60-mm (2³/₈-in.) diameter, cold-rolled steel revolving disks, each attached to motor-driven vertical shafts which also revolve about a vertical axis. The inside diameter of the resulting circular and abraded track shall be approximately ~~156~~ 150 mm (6 in.) and the outside diameter ~~276~~ 275 mm (~~10⁷/₈~~ 11 in.). Crossed slots 90° to each other and cut ~~4.8~~ 5 mm (³/₁₆ in.) deep and ~~6.4~~ 6 mm (1/4 in.) wide are located symmetrically in the abrasive flat faces.

4.2 The disks are free floating inasmuch as they are self-supporting and are driven transversely along a circular path at 12 rev/min (12 rpm) while being individually turned on their own axis at 280 rev/min (280 rpm). Cups attached at the top of the shaft

² Annual Book of ASTM Standards, Vol 04.02.

³ These machines are available from White Machine Co., 9591 York Alpha Dr., North Royalton, OH 44133; Spirit Fabricating, Ltd., 9260 Valley View Rd., Macedonia, OH 44056.

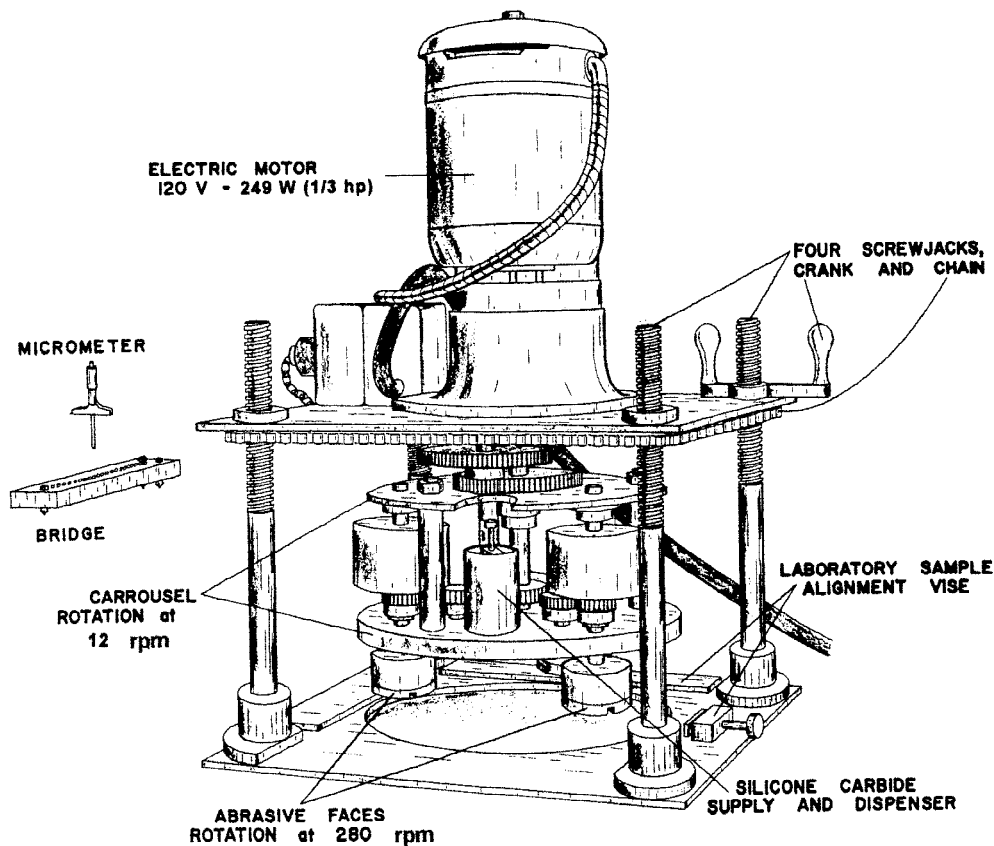

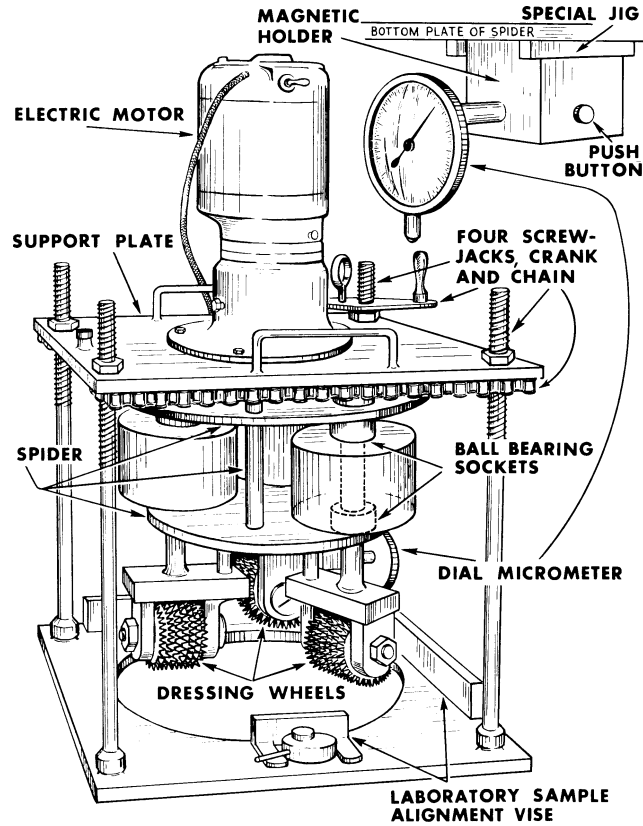

FIG. 2 Dressing Wheel Abrasion Test Machine

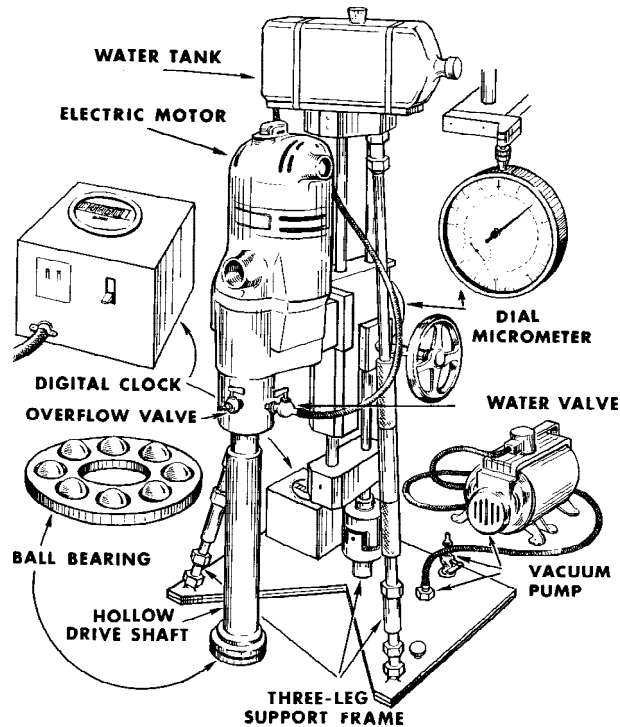

FIG. 3 Ball Bearing Abrasion Test Machine

of each disk shall be loaded with lead shot to produce a uniform total load of 22 N (5 lbf) on each abrading disk face.

4.3 The abrasive grit shall consist of 250 μ [No. 60] silicon carbide. This is fed from a storage cup mounted on the revolving circular plate through a 3.2-mm 3-mm (1/8-in.) orifice passing through the plate. The flow of abrasive shall be controlled to a rate

of 4 to 6 g/min by an adjusting needle located in the orifice. The abrasive falls at the midwidth of the circular abraded track, and midway between two of the disks.

4.4 The micrometer bridge consists of a machine-finished 25-mm (1-in.) rectangular steel bar of at least 3050-mm (12-in.), clear span supported by a tripod and drilled along its centerline with ten ~~3.2-mm~~ 3-mm ($\frac{1}{8}$ -in.) diameter holes spaced ~~6.4 mm~~ 6-mm ($\frac{1}{4}$ in.) on center. The measuring instrument is a depth micrometer with a needle having an effective depth range of 25 to 50 mm (1 to 2 in.) and graduated ~~in~~ to an accuracy of at least 0.025 mm (0.001 in.).

5. Test Specimen

5.1 For laboratory test purposes, the machine is designed to accommodate approximately 300 by 300-mm (12 by 12-in.) test specimens. The apparatus is equipped with an adjusting handle linked by a sprocket and chain-drive assembly to the four 25-mm (1-in.) diameter posts which support the entire rotating abrasion element. This feature permits the abrasion of test panels up to approximately ~~95 mm (3¾ in.)~~ 100-mm (4-in.) in thickness. A zero adjustment in the height of the abrasion assembly also permits the use of the apparatus as a portable device for measuring the abrasion resistance on the surfaces in place as well as on test specimens.

6. Procedure

6.1 Prior to the test period, precondition the sample to remove curing compound and surface irregularities by running the abrasion machine for 5 min, after which the initial measurements shall be taken. Obtain initial measurements ~~to the nearest~~ an accuracy of at least 0.025 mm (0.001 in.) of the test area by taking two series of 20 measurements each. Place the micrometer bridge so that the line of the second series of readings bisects at right angles to the first series of measurements. In making measurements subsequent to the abrasion period, take care that the micrometer bridge is placed in precisely the same position in which the reference measurements were obtained. To ensure this, outline the ends of the positioned micrometer bridge on the surface prior to making the initial measurements.

6.2 A test period of 30 min generally produces significant wear on most concrete surfaces, but it is recommended to extend the test period to 60 min, if information on the longtime abrasion resistance is desired.

6.3 In using the device as a portable apparatus, take care in the selection of the areas to be tested. Although the base of the apparatus is equipped with rubber pads, not only to prevent the apparatus from creeping during the abrasion operation but also to minimize the effect of slight variations in the level of the test areas. Select test areas with a minimum of variation in level so as to eliminate the creeping effect.

6.4 Take measurements of depth wear with a micrometer bridge as described in 4.4 to ~~the nearest~~ an accuracy of at least 0.025 mm (0.001 in.). Prior to each set of measurements, clean the specimen surface carefully by removing loose particles.

6.5 Make three tests on surfaces representative of the concrete to be evaluated. When wear of the disks reduces the depth of the slots to less than ~~4.6~~ 1.5 mm ($\frac{1}{16}$ in.), they shall be replaced. New disk faces shall be subjected to a break-in period of at least 15 min.

7. Interpretation of Results

7.1 The comparison of measurements of average depth of wear of representative surfaces at 30 and 60-min exposure to abrasion will indicate the relative abrasion resistance of these surfaces.

8. Report

8.1 Report the depth of wear of each surface tested as well as the average obtained on replicate surfaces.

8.2 Record mixture proportions (including cement content and water-cement ratio), specific gravities, grading of fine and coarse aggregates, Los Angeles abrasion test results, type and amount of material added to freshly placed concrete surface, type and extent of troweling, curing details, and age of concrete when tested.

PROCEDURE B—DRESSING WHEELS

9. Apparatus

9.1 The function of the apparatus is dependent upon the abrasive action of three sets of steel dressing wheels⁴ riding in a circular path over a horizontal concrete surface. The dressing wheels in each of the three sets of wheels turn freely on a horizontal axle at the bottom of a free-floating, weighted, vertical steel shaft.

9.2 Each of the three sets of seven dressing wheels are spaced so that each set cuts approximately a 40-mm (1½-in.) wide path. The machine produces a circular abrasion path of about 140-mm (5½-in.) inside diameter and ~~215-mm~~ 220-mm (8½-in.) outside diameter.

⁴The precision

⁴Dressing wheels of this test method has been found to depend primarily on the procedure used and not on the depth and period of abrasion and the age of concrete after casting; a suitable type may be purchased from sources, such as Desmond-Stefan Manufacturing Co., 713 South Walnut, Urbana, OH.

9.3 The apparatus shall consist of a motor-driven spider arrangement turning at 56 rev/min (56 rpm). The motor shall be mounted on a horizontal plate supported by four screw jacks allowing the motor to be raised and lowered. The spider shall be hung from the vertical motor shaft. The three vertical shafts shall be mounted in the spider arrangement so that they rotate with the spider and are free to move up and down in independent thrust-bearing sockets.

9.4 The three shafts shall be fitted with a yoke inside, upon which a series of seven dressing wheels are placed on a horizontal axle. The mass of each complete dressing wheel assembly as it bears on the concrete surface shall be 7.5 kg (16.5 lb).

9.5 The dressing wheels shall have an outside diameter of 60 mm ($2\frac{3}{8}$ in.) and a thickness of ~~3.2~~ 3 mm ($\frac{1}{8}$ in.) and shall be provided with 18 flattened points, each having dimensions of ~~3.18~~ 3.0 by ~~1.2~~ 2.0 mm (0.125 by 0.075 in.). The dressing wheels shall be assembled on the shaft alternated with steel washers. The total width of seven dressing wheels and eight washers shall be approximately 40 mm ($1\frac{1}{2}$ in.). The dressing wheels must be loose enough to turn freely and independently.

9.6 The measuring instrument shall be a dial micrometer, reading to an accuracy of at least 0.025 mm (0.001 in.) with a range of at least ~~7.10~~ 10 mm (0.34 in.). The contact end of the micrometer spindle shall have a spherical surface of 9.5-mm ($\frac{3}{8}$ -in.) diameter. A jig located on the underside of the spider holds the micrometer magnetically in the approximate center of the path of the dressing wheels.

10. Test Specimen

10.1 Place a sample approximately 300 by 300 by ~~95-mm~~ 100-mm (12 by 12 by ~~$3\frac{3}{4}$ -in.~~) 4-in. thick into the machine and lock it in place with vises provided. Do not remove the sample until the test is completed. Test three identical samples.

11. Procedure

11.1 Position the abrasion apparatus over surface to be tested. Rubber pads on the bottom of machine will hold the machine in place. Turn the screw crank until the full weight of each dressing-wheel shaft is resting on the concrete surface. Lower the spider as far as possible without exerting any pressure from the spider itself onto these three shafts. Allow a spacing of ~~13~~ 15 mm (0.5 in.) for vertical travel of the dressing wheels. Lock the screw crank to prevent any change in vertical movement of the spider during testing.

11.2 Take an initial measurement to the nearest 0.025 mm (0.001 in.) on the test area with the dial micrometer in place while revolving the spider two revolutions by hand. Record this initial reading as a reference reading and then remove the micrometer. Start the machine and let it run for 30 min, brush off the loose material, insert the dial micrometer, and record the average reading again. If the readings are not reasonably uniform, record several readings taken around the circumference of the abraded surface from which the average reading may be computed. The difference between the reference reading and the 30-min reading is indicative of the depth of wear.

11.3 Make three tests on surfaces representative of the concrete to be evaluated. After every third test, install new dressing wheels.

11.4 A test period of 30 min generally produces significant wear on most concrete surfaces, but it is recommended to extend the period to 60 min, if simulation of more severe abrasion is desired. Take depth-of-wear readings at 15-min intervals to the nearest 0.025 mm (0.001 in.) to obtain a time versus wear curve.

12. Interpretation of Results

12.1 The comparison of measurements of average depth of wear of representative surfaces at 30 and 60-min exposure to abrasion will indicate the relative abrasion resistance of these surfaces.

12.2 A comparison of curves will indicate whether the resistance to abrasion is primarily at the surface or at a greater depth.

13. Report

13.1 Plot the time versus depth of wear of tests performed for 30 and 60-min durations on three representative surface locations or specimens and determine the average line.

13.2 Record the mixture proportions including cement content and water-cement ratio, specific gravities, grading of fine and coarse aggregates, Los Angeles abrasion test results, type and amount of material added to freshly placed concrete surface, type and extent of troweling, curing details, and age of concrete when tested.

PROCEDURE C—BALL BEARINGS

14. Apparatus

14.1 The function of the apparatus is dependent upon the abrasive action of a rapidly rotating ball bearing under load on a wet concrete test surface. Water is used to flush out loose particles from the test path, bringing the ball bearing in contact with sand and stone particles still bonded to the concrete surface, thus providing impact as well as sliding friction.

14.2 The apparatus shall consist of a motordriven, hollow, vertical shaft resting on and turning ball bearings which rest on the concrete surface. As the ball bearings cut into the concrete surface, depth-of-wear readings can be taken continuously without stopping the test.

14.3 A digital clock shall be electrically connected to the drive motor so that both the drive motor and the clock can be started simultaneously. The clock shall read in seconds up to 9999 s.

14.4 The abrasion tool shall be composed of eight 18-mm ($23/32$ -in.) diameter steel balls equally spaced in a retainer ring. The diameter of the ball circle shall be ~~63.5~~ 60 mm ($2\frac{1}{2}$ in.). ~~The wear abrasion tool shall be given a breaking-in period of 300 s. During this period the steel balls will become slightly textured, leaving an apparent larger diameter. The wear abrasion tool shall be discarded when the diameter of the steel ball has been reduced to~~ 17.8 mm (0.718 (0.7 in.)).

NOTE 3—During this period the steel balls will become slightly textured, leaving an apparent larger diameter.

14.5 The hollow vertical drive shaft shall be provided with a flanged bearing plate at its lower end, grooved to match the ball circle of the abrasion tool, and a centered ~~3.2-mm~~ 3-mm ($1/8$ -in.) diameter orifice to permit a constant flow of water. The drive shaft shall be further provided with an adjustment of plumbness to the test surface. The total load on the ball bearing shall be 120 N (27 lbf) including the weight of drive motor, hollow drive shaft, and contained water. The motor shall be capable of revolving the drive shaft at ~~1000-rev/min~~ rpm/min (1000 rpm) under load.

14.6 The dial indicator shall have a travel of ~~13~~ 15 mm ($1/2$ in.) and ~~read to the nearest~~ an accuracy of at least 0.025 mm (0.0001 in.).

14.7 A ~~1-gal (3.8-L)~~ 4-L (1-gal) plastic tank mounted on the motor base supplies water which flows by gravity through the hollow drive shaft and orifice in the flange plate onto the concrete surface.

14.8 The machine base shall be provided with a vacuum hold-down device having three support points.

15. Test Specimen

15.1 When tests are run on concrete specimens rather than on a concrete slab in place, mount the samples securely so as to have a rigidity approximating that of a slab in place. This can be achieved by using bonding agents or a vacuum to hold the test sample to the horizontal surface upon which the machine is mounted.

15.2 Use test samples 300 by 300 by ~~95-mm~~ 100-mm (12 by 12 by ~~3 $3/4$ -in.~~) 4-in.) thick. The rate of wear on this size sample has been found to be about 90 % of the rate of wear of a concrete slab in place. The size of the test specimen will affect the rate of wear measured by this test method.

16. Procedure

16.1 Mount the machine firmly and securely on a concrete surface by use of a vacuum hold-down device.

16.2 Place a sheet of paper between the test surface and the ball bearings under the load of the motor. Revolve the drive shaft several times by hand. A complete circular mark formed on the paper indicates the drive shaft is normal to the surface. If a crescent is formed, adjust the plumbness of the drive shaft and repeat the procedure until a circle is obtained.

16.3 Open the two valves at the base of the drive motor; one to allow water to fill the hollow drive shaft, the other to determine that the hollow shaft is filled. Then close the overflow valve. Fill the water tank to the prescribed mark to assure a standard initial head.

16.4 Bring the dial gage clamped to the supporting shaft to bear on the sliding bracket of the motor and drive shaft. Reset the digital clock to zero.

16.5 Take the reference dial micrometer reading immediately following the slight jump of the dial, just after the motor is started.

16.6 Take dial micrometer readings ~~to the nearest~~ an accuracy of at least 0.025 mm (0.001 in.) of the depth of abrasion at least every 50 s for a total period of 1200 s, or until a maximum depth of 3.0 mm (0.1225 in.) is reached. Take an average reading of the pulsating micrometer dial.

16.7 Take three tests on surfaces representative of the concrete to be evaluated.

17. Interpretation of Results

17.1 Determine the depth of wear for each interval of the test. The comparison of curves showing a plot of depth of wear versus time for each series of concrete surfaces tested will indicate the relative abrasion resistance of these surfaces.

17.2 A material that is uniform in abrasion resistance will have a curve approximating a half-parabola inclined toward the time axis. A comparison of curves will indicate whether the resistance to abrasion is primarily at the surface or at greater depth.

17.3 When comparing test results of concrete surfaces of a wide range in abrasion resistance, establish the time required to reach a particular depth.

18. Report

18.1 Plot the time versus depth of wear of tests performed on three representative concrete surfaces and determine the average line.

18.2 Record mixture proportions including cement factor and water-cement ratio, specific gravities, and grading of fine and coarse aggregates, Los Angeles abrasion test results, type and amount of material added to freshly placed concrete surface, type and extent of troweling, curing details, and age of concrete when tested.

TABLE 1 Within-Laboratory Precision for Single Operator

Procedure	Coefficient of Variation, Percent of Mean ^A	Acceptable Range of Two Results, Percent of Mean ^A
A Revolving disk	5.51	15.6
B Dressing wheel	11.69	33.1
C Ball bearing	17.74	50.2

^A These numbers represent respectively the 1s % and d2s % limits as described in Practice C 670, in the section on Alternative Form of the Precision Statement.

19. Precision and Bias

19.1 *Precision*—Criteria for judging the acceptability of abrasion resistance test results obtained by this method⁵ are given as follows:

NOTE 34—The figures given in Table 1 column 2 are the coefficients of variation that have been found to be appropriate for the materials and conditions of test as determined with inch-pound units and equipment as described in column 1.

19.2 *Bias*—Since there is no acceptable reference material suitable for determining bias for the procedure in this test method, no statement on bias is being made.

20. Keywords

20.1 abrasion; concrete; impact; surface treatments; wear

⁵ The precision of this test method has been found to depend primarily on the procedure used and not on the depth and period of abrasion and the age of concrete after casting.

ASTM International takes no position respecting the validity of any patent rights asserted in connection with any item mentioned in this standard. Users of this standard are expressly advised that determination of the validity of any such patent rights, and the risk of infringement of such rights, are entirely their own responsibility.

This standard is subject to revision at any time by the responsible technical committee and must be reviewed every five years and if not revised, either reapproved or withdrawn. Your comments are invited either for revision of this standard or for additional standards and should be addressed to ASTM International Headquarters. Your comments will receive careful consideration at a meeting of the responsible technical committee, which you may attend. If you feel that your comments have not received a fair hearing you should make your views known to the ASTM Committee on Standards, at the address shown below.

This standard is copyrighted by ASTM International, 100 Barr Harbor Drive, PO Box C700, West Conshohocken, PA 19428-2959, United States. Individual reprints (single or multiple copies) of this standard may be obtained by contacting ASTM at the above address or at 610-832-9585 (phone), 610-832-9555 (fax), or service@astm.org (e-mail); or through the ASTM website (www.astm.org).