



Designation: **C 878/C 878M – 95a03**

Standard Test Method for Restrained Expansion of Shrinkage-Compensating Concrete¹

This standard is issued under the fixed designation C 878/C 878M; the number immediately following the designation indicates the year of original adoption or, in the case of revision, the year of last revision. A number in parentheses indicates the year of last reapproval. A superscript epsilon (ϵ) indicates an editorial change since the last revision or reapproval.

¹ This method is under the jurisdiction of ASTM Committee C-9, C09 on Concrete and Concrete Aggregates and is the direct responsibility of Subcommittee C09.68 on Volume Change of Concrete and Aggregates—Change.

Current edition approved April 15 and July 15, 1995; Jan. 10, 2003. Published September 1995; April 2003. Originally published as C 878—78; approved in 1978. Last previous edition C 878—87; approved in 1995 as C 878—95a.

1. Scope

1.1 This test method covers the determination of the expansion of concrete made with shrinkage-compensating cement.

1.2 The values stated in either SI units or inch-pound units are to be regarded separately as the standard. The values stated in parentheses are for information purposes only; each system may not be exact equivalents; therefore, each system shall be used independently of the other. Combining values from the two systems may result in non-conformance with the standard.

1.3 *This standard does not purport to address all of the safety concerns, if any, associated with its use. It is the responsibility of the user of this standard to establish appropriate safety and health practices and determine the applicability of regulatory limitations prior to use.*

2. Referenced Documents

2.1 *ASTM Standards:*

C 125 Terminology Relating to Concrete and Concrete Aggregates²

C 157/C 157M Test Method for Length Change of Hardened Hydraulic Cement, Mortar, and Concrete²

C 192/C 192M Practice for Making and Curing Concrete Test Specimens in the Laboratory²

C 219 Terminology Relating to Hydraulic Cement³

C 403/C 403M Test Method for Time of Setting of Concrete Mixtures by Penetration Resistance²

C 490 Practice for Use of Apparatus for the Determination of Length Change of Hardened Cement Paste, Mortar, and Concrete³

C 670 Practice for Preparing Precision and Bias Statements for Test Methods for Construction Materials²

C 806 Test Method for Restraint Expansion of Expansive Cement Mortar³

C 845 Specification for Expansive Hydraulic Concrete Cement³

2.2 *ACI Standards and Committee Reports:*⁴

116-R-90 Cement and Concrete Terminology

223-83 Standard Practice for the Use of Shrinkage-Compensating Concrete

3. Terminology

3.1 Terms used in this test method are defined in Terminology C 219, Terminology C 125, and ACI 116-R-90.

4. Significance and Use

4.1 Since the potential for expansion, under conditions of controlled restraint, of concrete made with shrinkage-compensating cement cannot always be satisfactorily predicted from tests of mortars made in accordance with Test Method C 806, a need has been recognized for a test method in which concrete specimens are tested.

4.2 This test method can also be adapted readily to studies of expansion involving degrees of restraint, comparisons of cements, effects of cement contents, mixture proportions, schedules, or environmental treatments that differ from the standard procedures prescribed by this test method.

² *Annual Book of ASTM Standards*, Vol 04.02.

³ *Annual Book of ASTM Standards*, Vol 04.01.

⁴ Available from American Concrete Institute (ACI), P.O. Box 19150, Detroit, 9094, Farmington Hills, MI-48249; 48333.

5. Apparatus

5.1 *Molds*, for casting test specimens, when used in conjunction with the restraining cage described in 4.2, shall provide for forming prisms ~~3 in. (76 mm)~~ 76 mm [3 in.] square with a gage length of ~~10 in. (254 mm)~~ 250 mm [10 in.]. The molds shall otherwise conform to the requirements of for molds in Practice C 490, except that the stud holder, gage studs, and spacer screws described in that specification practice will not be used.

5.2 *Restraining Cage*, consisting of a threaded ~~10-24~~ low-carbon steel rod (plain or zinc-coated) with steel end plates held in place by hex nuts as shown in Fig. 1. The hex nuts outside the cage shall be of stainless steel. Stainless steel cap nuts shall be put on each end of the rod. When tested in tension, within the elastic range, the rod shall have a strain of 2800 kN [0.0012 ± 0.0001/630 lbf (2802 kN) lbf] of load (Note 1).

NOTE 1—It is intended that all rods used meet the indicated requirement for strain. When a large number of rods are obtained as a single lot, exercise judgment as to whether or not all must be tested. The designation “10-24” is used in ordinary rods having the desired properties.

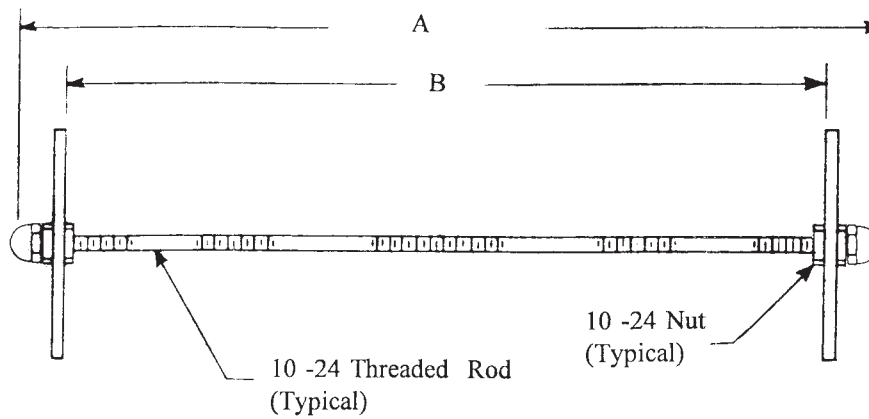

Assembled Restraining Cage

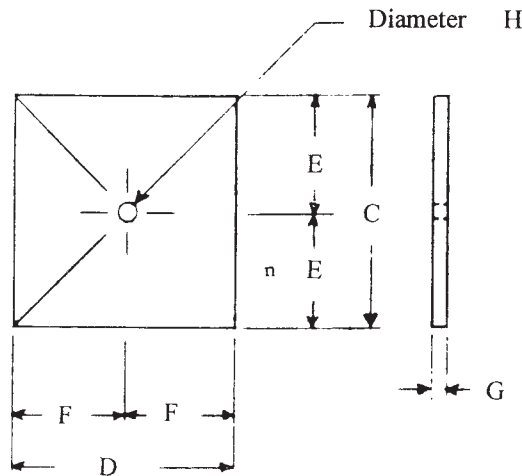

Measurement	Dimensions	
	in.	mm
A	$11\frac{9}{16} \pm \frac{1}{16}$	294 ± 1.6
B	10	254 (gage length)
C	3	76
D	$2\frac{3}{32} \pm \frac{1}{32}$	75 ± 1
E	$1\frac{1}{2}$	38
F	$1\frac{3}{64}$	37.7
G	$\frac{3}{8}$	10
H	$\frac{3}{16}$	5

NOTE 1—All material is mild steel, except for stainless steel cap nuts.

FIG. 1 Restraining Cage

5.3 *Length Comparator*, conforming to and to be used in accordance with the requirements of Practice C 490. ~~A Use a reference bar complying with the description given in Practice C 490 shall be used.~~ C 490. If the terminals of the comparator are fitted with collars, they shall be such that the cap nuts on the ends of the threaded rod of the specimen do not rest on the collar during the measuring (see Figs. 2 and 3).

5.4 *Tamping Rod*—The tamping rod shall be a straight steel rod, $\frac{3}{8}$ in. or 10 mm [$\frac{3}{8}$ in.] in diameter, and no less than 10 in. or 250 mm [10 in.] in length, having at least the tamping end rounded to a hemispherical tip of the same diameter.

5.5 *Vibrators*, conforming to the requirements for external vibrators prescribed in Practice C 192/C 192M.

6. Test Specimens

6.1 The test specimen shall be a prism: ~~3 in. (76 mm)~~ 75 mm [3 in.] square with a gage length of ~~10 in. (254 mm)~~ 250 mm [10 in.] and an overall length (including the length of the rod and cap nuts) of approximately ~~11½ in. (292 mm)~~ 290 mm [11.5 in.]. At least three specimens shall be prepared for each test.

NOTE 2—**Caution:** Aggregate sizes ~~2~~—Use of aggregates of nominal maximum size greater than 25.0 mm [1 in.] may adversely affect the test results.

7. Preparation and Assembly of Specimen Molds and Restaining Cage

7.1 Install the cap nuts firmly in place on the ends of the restraining rods using a suitable adhesive to keep them from loosening when comparator readings are made (Note 3). The cap nuts should not be removed after ~~the~~ initial comparator reading of ~~each~~ sample a specimen is made. Measure the restraining cage assembly length, including the cap nuts, while it is at $73.4 \pm 1^\circ\text{F}$ (or $23.0 \pm 0.5^\circ\text{C}$), 2°C [$73.5 \pm 3.5^\circ\text{F}$]. This is to ensure it is 30 ± 2 mm [$1\frac{1}{16} \pm \frac{1}{16}$ in. (or 294 ± 1.6 mm); in.]. The measurement taken at this time is ~~to be used only to ensure that comparator readings can be made.~~

NOTE 3—A rapid-setting epoxy has been found suitable.

7.2 Thinly cover the edges of the restraining cage end plates that contact the sides and bottom of the mold ~~shall be thinly covered~~ with a heavy mineral oil or light cup grease such as petrolatum. After assembly of the molds, place a restraining cage in each mold compartment. Seal the contact lines between the outer sides and base plate of the molds with paraffin or micro-crystalline wax. Thinly cover the interior faces of the molds with mineral oil and remove any oil or grease from the restraining cage rod and end plates.

8. Procedure

8.1 *Preparation and Mixing of Materials*—Mixtures using job materials ~~should~~ shall be made in the laboratory as described in Practice C 192/C 192M, except that the material temperatures ~~should~~ shall be approximately those anticipated in the field. Mixing

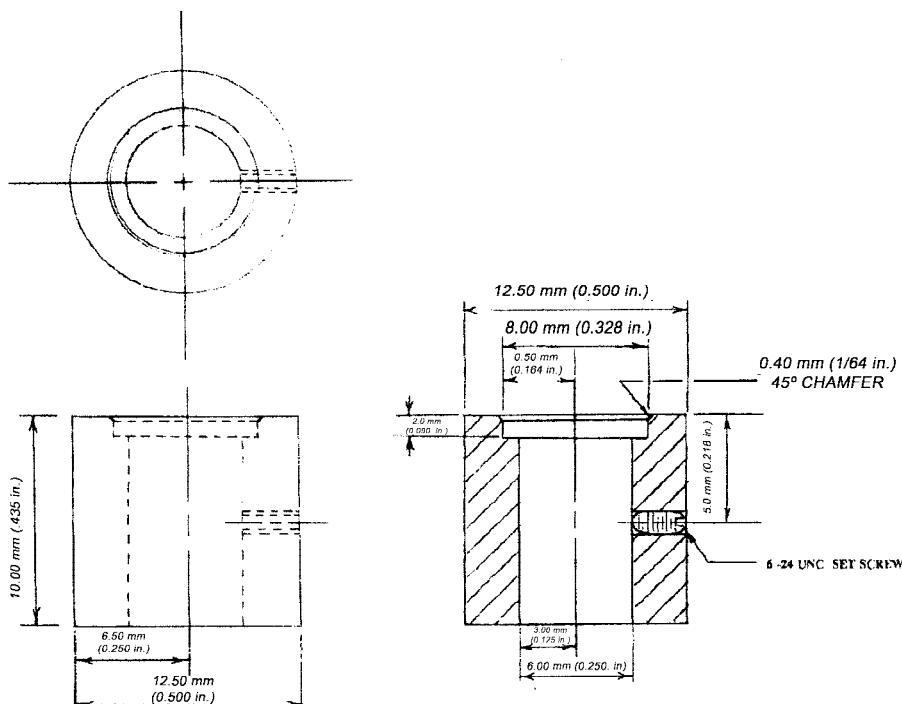

FIG. 2 Schematic of Upper and Lower Adjustable Restraining Collar for Length Comparator that Will Allow Positioning of Restraining Cage Cap Nuts to Rest on Anvils Without Interference from the Collars

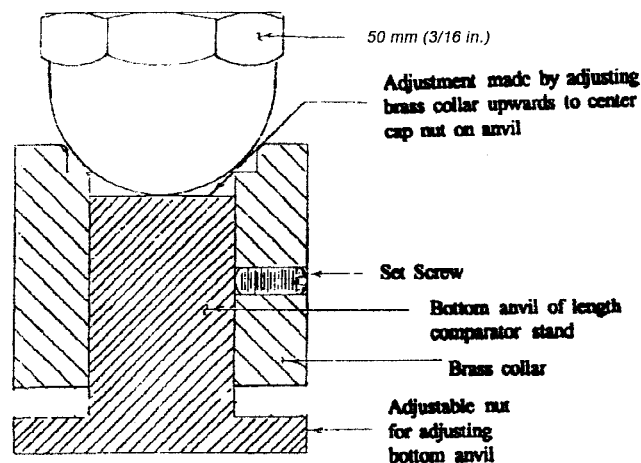

FIG. 3 Cross Section of Restraining Collar Showing Positioning of Cap Nut for Measurement

procedures ~~should~~ shall also reflect the actual mixing and delivery times expected for the particular work. Remove aggregate retained on the ~~1 in. (25.0 mm)~~ 25.0 mm [1 in.] sieve from that used in the mixture from which the specimens are to be molded. Select the mixture proportions according to applicable provisions of ACI 223. ~~NOTE 3—A rapid-setting epoxy has been found suitable.~~

8.2 *Molding Specimens*—Place the concrete in the mold in two approximately equal layers (the first layer ~~should~~ shall just cover the threaded restraining rod) in accordance with the general instructions given for placing concrete in specimen molds given in Practice C 192/C 192M. Consolidate each layer by rodding or by external vibration in accordance with the instructions for consolidation of flexure test specimens given in Practice C 192/C 192M, except use the same method of consolidation for all specimens to be compared. The top layer shall slightly overfill the mold. After consolidation is complete, strike off the excess material with a straightedge and finish the exposed surface with a few strokes of a straight-edged trowel.

8.3 *Curing Specimens*—Cover the specimens with a polyethylene sheet or other suitable material to prevent loss or gain of moisture at the surface of the specimens.

8.4 Remove the specimens from the molds at the age of 6 h. In unusual cases the specimens may not be strong enough to demold at the age of 6 h. If this is the case, select a later time but demold as soon as practicable and report the demolding age with the results. Remove the specimens from the molds by loosening or removing the mold-fastening devices and gently tapping the base plate and side plates so as to free them from the specimens. Exercise great care in this operation, because of the fragility of the concrete at this age and in all later handling of specimens. Do not place specimens directly on hard wood or metal table tops. Placing a soft rubber mat over table tops to lessen impact force on specimens has been found to reduce scatter in data. Limit any marks placed on the specimens for identification or positioning to those made by graphite applied either by a soft pencil or as a liquid that deposits essentially graphite without binder, to those made with waterproof indelible ink, or to light scratchings in the surface of the concrete made with a sharp instrument.

8.5 *Measuring Specimens*—Take the initial comparator readings 30 ± 2 min after demolding. After the initial comparator reading, cure the specimens in lime-saturated water at ~~73.4~~ $23 \pm 3^\circ\text{F}$ ($23 \pm 2^\circ\text{C}$) [$73.5 \pm 1.7^\circ\text{C}$] 3.5°F] until they have reached an age of 7 days. At the end of the curing period take another comparator reading. ~~If desired, it is permitted for comparator readings may to be taken at intermediate ages between the initial comparator reading and the comparator reading at 7 days. Further water-curing may be continued days (Note 4).~~

~~NOTE 4—It is permitted to provide further water-curing, or alternatively the specimens may shall be allowed to air-dry under any desired condition in order to determine later age length change data. Comparator readings may shall be taken at any appropriate interval.~~

9. Calculation

9.1 Calculate the length changes as percent expansion or shrinkage as follows:

$$\text{Length change, \%} = \frac{[(\text{corrected comparator reading} - \text{corrected initial comparator reading}) / \text{gage length}] \times 100}{(1)}$$

where the corrected comparator reading is equal to the specimen comparator reading minus the reference bar comparator reading.

10. Report

10.1 Report the following information:

- 10.1.1 Identification of specimens, number of specimens for each condition, and date molded,
- 10.1.2 Source and identification of each material employed,
- 10.1.3 Type, nominal maximum size, moisture condition, and proportions of each aggregate used,
- 10.1.4 Concrete mixture data,
- 10.1.5 Consolidation method, whether rodding or external vibration was used,
- 10.1.6 Conditions and periods of moist- curing prior to and subsequent to removal of molds, if different from those specified.
- 10.1.7 Description of storage conditions,
- 10.1.8 Total length of the period of storage and total age of the specimen, or total length of curing and storage if the same condition was used for both, for each observation, and
- 10.1.9 ~~Report~~ length change data, in % , recorded as linear expansion during moist-curing and moist storage and as linear contraction during dry storage both based on the initial comparator reading made at the time of removal from the molds, ~~shall be reported~~ as the average percent change in linear dimension to the nearest 0.001 %.
- 10.1.10 Any other pertinent information.

11. Precision and Bias

11.1 *Precision:*

11.1.1 The following precision statements are applicable when a test result is the average percent restrained expansion of ~~3-bars~~ prisms molded from a single batch of concrete and tested at the same age. It is applicable for concrete made from Type K, Type S, or Type M shrinkage-compensating cements (C 845) and tested at 3, 7, or 28 days.

11.2 The multilaboratory standard deviation has been found to be 0.015 % expansion. Therefore, the results of properly conducted tests of a single batch by two different laboratories should not differ from each other by more than 0.043 %⁵ ~~Therefore, the results of properly conducted tests of a single batch by two different laboratories should not differ from each other by more than 0.043 %⁵.~~

11.3 Data necessary to determine single-laboratory precision are not available at this time.

11.4 *Bias*—Data to determine bias are not available; no standards are known to exist.

12. Keywords

12.1 expansion; restrained expansion; shrinkage compensating concrete

⁵ These numbers represent, respectively, the (t1s) and s (d2s) limits as described in Practice C 670.



C 878/C 878M – 95a03

ASTM International takes no position respecting the validity of any patent rights asserted in connection with any item mentioned in this standard. Users of this standard are expressly advised that determination of the validity of any such patent rights, and the risk of infringement of such rights, are entirely their own responsibility.

This standard is subject to revision at any time by the responsible technical committee and must be reviewed every five years and if not revised, either reapproved or withdrawn. Your comments are invited either for revision of this standard or for additional standards and should be addressed to ASTM International Headquarters. Your comments will receive careful consideration at a meeting of the responsible technical committee, which you may attend. If you feel that your comments have not received a fair hearing you should make your views known to the ASTM Committee on Standards, at the address shown below.

This standard is copyrighted by ASTM International, 100 Barr Harbor Drive, PO Box C700, West Conshohocken, PA 19428-2959, United States. Individual reprints (single or multiple copies) of this standard may be obtained by contacting ASTM at the above address or at 610-832-9585 (phone), 610-832-9555 (fax), or service@astm.org (e-mail); or through the ASTM website (www.astm.org).