



## Standard Test Method for Float Test for Bituminous Materials<sup>1</sup>

This standard is issued under the fixed designation D 139; the number immediately following the designation indicates the year of original adoption or, in the case of revision, the year of last revision. A number in parentheses indicates the year of last reappraisal. A superscript epsilon ( $\epsilon$ ) indicates an editorial change since the last revision or reappraisal.

### 1. Scope

1.1 This test method covers the float test for bituminous materials.

1.2 *This standard does not purport to address all of the safety concerns, if any, associated with its use. It is the responsibility of the user of this standard to establish appropriate safety and health practices and determine the applicability of regulatory limitations prior to use.* For a specific precaution statement, see 6.1.

1.3 The values stated in SI units are to be regarded as the standard. The values given in parentheses are for information only.

### 2. Referenced Documents

#### 2.1 ASTM Standards:

C 670 Practice for Preparing Precision and Bias Statements for Test Methods for Construction Materials<sup>2</sup>

D 140 Practice for Sampling Bituminous Materials<sup>3</sup>

D 244 Test Methods for Emulsified Asphalts<sup>3</sup>

D 2170 Test Method for Kinematic Viscosity of Asphalts (Bitumens)<sup>3</sup>

E 1 Specification for ASTM Thermometers<sup>4</sup>

### 3. Summary of Test Method

3.1 A plug of bitumen is cast in a tapered collar. The assembled float and collar is then floated in the testing bath at the specified temperature. The time, in seconds, between placing the apparatus on the water and the water breaking through the material shall be taken as a measure of the consistency of the material under examination.

### 4. Significance and Use

4.1 The float test characterizes the flow behavior or consistency of certain bituminous materials.

4.2 This test method is useful in determining the consistency of bitumen as one element in establishing the uniformity of certain shipments or sources of supply.

### 5. Apparatus

5.1 *Float*—The float (Fig. 1) shall be made of aluminum or aluminum alloy and shall be in accordance with the following requirements:

	Min	Normal	Max
Mass of float, g	37.70	37.90	38.10
Total height of float, mm	34.0	35.0	36.0
Height of rim above lower side of shoulder, mm	26.5	27.0	27.5
Thickness of shoulder, mm	1.3	1.4	1.5
Diameter of opening, mm	11.0	11.1	11.2

5.2 *Collar*—The collar (Fig. 1) shall be made of brass and shall be in accordance with the following requirements:

	Min	Normal	Max
Mass of collar, g	9.60	9.80	10.00
Over-all height of collar, mm	22.3	22.5	22.7
Inside diameter at bottom, mm	12.72	12.82	12.92
Inside diameter at top, mm	9.65	9.70	9.75

The top of the collar shall screw up tightly against the lower side of the shoulder.

5.3 *Calibration of Assembly*—The assembled float and collar, with the collar filled flush with the bottom and weighted to a total mass of 53.2 g, shall float upon water with the rim 8.5  $\pm$  1.5 mm above the surface of the water. This adjustment of the total mass of the assembly is for the purpose only of calibrating the depth of immersion in the testing bath.

5.4 *Thermometer*—An ASTM Low Softening Point Thermometer, graduated in either Celsius or Fahrenheit degrees as specified, having a range from  $-2$  to  $+80^{\circ}\text{C}$  or  $+30$  to  $+180^{\circ}\text{F}$  and conforming to the requirements for Thermometer  $15^{\circ}\text{C}$  or  $15^{\circ}\text{F}$ , respectively, as prescribed in Specification E 1.

5.4.1 A thermometer consisting of K type 30 AWG gage thermocouple and a meter capable of reading  $25^{\circ}\text{C}$  ( $77^{\circ}\text{F}$ ) to  $260^{\circ}\text{C}$  ( $500^{\circ}\text{F}$ ). The thermocouple shall be 61 to 76 cm (24 to 30 in.) in length. This thermometer shall conform to the temperature/voltage tables of the National Institute of Standards and Technology and to the IEC 584 standards for K-, J-, and T-type thermocouples.<sup>5</sup>

5.5 *Testing Bath*—A circular bath of at least 185 mm in internal diameter and containing water at least 185 mm in depth; or a rectangular bath with minimum internal dimensions of 150 mm width and 300 mm length, and containing water at least 110 mm in depth. The height of the surface of the container above the water shall be at least 40 mm. The bath

<sup>1</sup> This test method is under the jurisdiction of ASTM Committee D-4 on Road and Paving Materials and is the direct responsibility of Subcommittee D04.44 on Rheological Tests.

Current edition approved Feb. 15, 1995. Published April 1995. Originally published as D 139 – 22 T. Last previous edition D 139 – 90<sup>e1</sup>.

<sup>2</sup> Annual Book of ASTM Standards, Vol 04.02.

<sup>3</sup> Annual Book of ASTM Standards, Vol 04.03.

<sup>4</sup> Annual Book of ASTM Standards, Vol 14.03.

<sup>5</sup> Tegam Model 819 meter is an appropriate meter for this purpose.

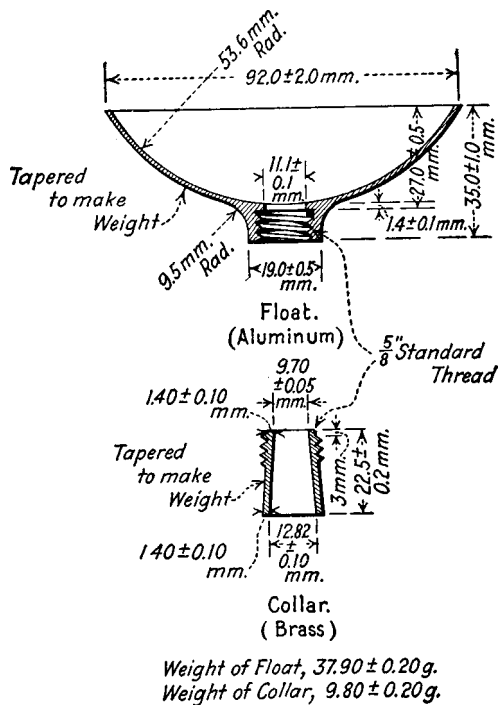

FIG. 1 Float Test Apparatus

The pouring temperature for high float emulsion residues can be critical. If a high float residue sample fails or appears to be poured at a cooler than specified temperature, the specified pouring temperature shall be confirmed in a referee sample by use of a 30-gage thermocouple probe and instrument. Position the thermocouple probe into the top center of the collar from above. Record the maximum temperature measured while the residue is being poured into the collar. Fill the collar until slightly more than level with the top, and quickly remove the thermocouple.

7.3.1 Samples for which the minimum temperature reading of  $218^{\circ}\text{C}$  ( $425^{\circ}\text{F}$ ) was not attained shall not be tested for float.

7.4 *Asphalt and Asphalt Products*—Cool asphalt and asphalt products to room temperature for 15 to 60 min, then place them for 5 min in the water bath at  $5^{\circ}\text{C}$ , after which trim the surplus material flush with the top of the collar by means of a spatula or steel knife that has been slightly heated. Then place the collar and plate in the water bath at  $5^{\circ}\text{C}$  and leave them in this bath for not less than 15 nor more than 30 min.

7.5 *Tar Products*—Immediately immerse tar products for 5 min in the water bath at  $5^{\circ}\text{C}$ , after which trim the surplus material flush with the top of the collar by means of a spatula or steel knife that has been slightly heated. Then place the collar and plate in the water bath at  $5^{\circ}\text{C}$  and leave them in this bath for not less than 15 nor more than 30 min.

7.6 Heat the water in the testing bath to the temperature at which the test is to be made. This temperature shall not vary throughout the test more than  $0.5^{\circ}\text{C}$  from the temperature specified, using any suitable means of heating the bath, without stirring. Determine the temperature by immersing the thermometer with the bottom of the bulb at a depth of  $40 \pm 2$  mm below the water surface.

7.7 After the material to be tested has been kept in the water bath at  $5^{\circ}\text{C}$  for not less than 15 nor more than 30 min, remove the collar with its contents from the plate and screw into the aluminum float. Completely immerse the assembly for 1 min in the water bath at  $5^{\circ}\text{C}$ . Then remove the water from the inside of the float and immediately float the assembly on the testing bath. Lateral drift of the assembly shall be permitted, but no spinning motion shall be intentionally imparted thereto. As the plug of material becomes warm and fluid, it is forced upward and out of the collar until the water gains entrance into the saucer and causes it to sink.

7.8 Determine the time, in seconds, between placing the apparatus on the water and the water breaking through the material by means of a stop watch, and take as a measure of the consistency of the material under examination.

## 8. Precision and Bias

8.1 Criteria for judging the acceptability of float test results obtained by this test method are given in Table 1.

## 9. Keywords

9.1 asphalt; bitumen; float; high float; pouring temperature; tar

shall be heated by electric, gas, or other suitable means. A stand or other suitable support shall be available to hold the thermometer in the proper position in the bath during the test.

5.6 *Water Bath at  $5^{\circ}\text{C}$* —A water bath of suitable dimensions maintained at  $5.0 \pm 1.0^{\circ}\text{C}$ , which may be accomplished by means of melting ice.

5.7 *Brass Pouring Plate*—A flat, smooth brass plate approximately 75 by 50 mm that has been treated to prevent the bituminous material from adhering to it. A suitable treatment is to coat the plate just before use with a thin layer of a mixture of glycerin and dextrin, talc, or kaolin (china clay). Other plates or coatings, or both, may be used, providing similar results are achieved.

## 6. Precautions

6.1 Special precautions should be taken to ensure that the collar fits tightly into the float and to see that there is no seepage of water between the collar and float during the test.

## 7. Procedure

7.1 Place the brass collar with the smaller end on the coated plate.

7.2 Melt the sample completely at the lowest possible temperature that will bring it to a sufficiently fluid condition for easy pouring, excepting creosote-oil residues, which shall be mixed and poured at a temperature of  $100$  to  $125^{\circ}\text{C}$ . Stir the sample thoroughly until it is homogeneous and free from air bubbles. Then pour it into the collar in any convenient manner until slightly more than level with the top.

7.3 *Emulsified Asphalts*—Test the distillation residue in accordance with Section 96.1, Float Test, Test Methods D 244.

**TABLE 1 Precision**

NOTE 1—The values given in Column 2 are the coefficients of variation that have been found to be appropriate for the materials and conditions of test described in Column 1. The values given in Column 3 are the limits that should not be exceeded by the difference between the results of two properly conducted tests expressed as a percent of their mean.

Material and Type Index	Coefficient of Variation, % of Mean <sup>A,B</sup>	Acceptable Range of Two Results, % of Mean <sup>A,B</sup>
<i>Single-operator precision:</i>		
Coal tar at 32 and 50°C	2.3	6.5
Asphalt cements and asphalt emulsion residues (120 penetration and above) at 60°C	1.7	4.8
<i>Multilaboratory precision:</i>		
Coal tar at 32 and 50°C	4.2	11.9
Asphalt cements and asphalt emulsion residues (120 penetration and above) at 60°C	10.7	30.2

<sup>A</sup>The numbers represent respectively the (1s%) and (d2s%) limits as described in Practice C 670.

<sup>B</sup>For suggested style, see Section 11 of Test Method D 2170.

*The American Society for Testing and Materials takes no position respecting the validity of any patent rights asserted in connection with any item mentioned in this standard. Users of this standard are expressly advised that determination of the validity of any such patent rights, and the risk of infringement of such rights, are entirely their own responsibility.*

*This standard is subject to revision at any time by the responsible technical committee and must be reviewed every five years and if not revised, either reapproved or withdrawn. Your comments are invited either for revision of this standard or for additional standards and should be addressed to ASTM Headquarters. Your comments will receive careful consideration at a meeting of the responsible technical committee, which you may attend. If you feel that your comments have not received a fair hearing you should make your views known to the ASTM Committee on Standards, 100 Barr Harbor Drive, West Conshohocken, PA 19428.*