



Standard Practice for Sampling Bituminous Materials¹

This standard is issued under the fixed designation D 140; the number immediately following the designation indicates the year of original adoption or, in the case of revision, the year of last revision. A number in parentheses indicates the year of last reapproval. A superscript epsilon (ϵ) indicates an editorial change since the last revision or reapproval.

This standard has been approved for use by agencies of the Department of Defense.

1. Scope

1.1 This practice applies to the sampling of bituminous materials at points of manufacture, storage, or delivery.

1.2 The values stated in SI units are to be regarded as the standard. The values given in parentheses are for information only.

1.3 *This standard does not purport to address all of the safety concerns, if any, associated with its use. It is the responsibility of the user of this standard to establish appropriate safety and health practices and determine the applicability of regulatory limitations prior to use.*

2. Referenced Documents

2.1 ASTM Standards:

D 346 Practice for Collection and Preparation of Coke Samples for Laboratory Analysis²

3. Significance and Use

3.1 Sampling is as important as testing, and precautions shall be taken to obtain samples to show the true nature and condition of the materials.

3.2 Samples may be taken for either of the following two purposes:

3.2.1 To represent as nearly as possible an average of the bulk of the materials sampled, or

3.2.2 To ascertain the maximum variation in characteristics which the material possesses.

4. Precautions

4.1 Because of the numerous types and grades of bituminous materials that are alternately shipped and stored in the same or similar containers, the opportunity for contaminating these containers with residues, precipitates, or cleaning solvents is ever present. Numerous opportunities also exist for obtaining samples which are not strictly representative of the material or are contaminated after removal. Therefore it is incumbent upon the producer, transporter, user, and sampler to

exercise continuous precaution in the sampling and handling of these materials.

5. Selection of Samples

5.1 Whenever practicable, bituminous materials shall be sampled at the point of manufacture or storage, and at such time as to allow the tests controlling acceptance or rejection to be made in advance of shipment.

5.2 When the samples cannot be taken at the point of manufacture or storage, they shall be taken from the shipment immediately upon delivery.

6. Size of Samples

6.1 The sample size of liquid materials shall be as follows:

6.1.1 For routine laboratory examination, 1 L (1 qt) (emulsions 4 L (1 gal)),

6.1.2 From bulk storage, 4 L (1 gal), or

6.1.3 From barrels or drums, 1 L (1 qt).

6.2 The sample size of semisolid or solid materials shall be as follows:

6.2.1 From barrels, drums, or cakes, 1 to 2 kg (2 to 3 lb), or

6.2.2 From crushed or powdered material in bulk or bags, 1 to 2 kg (2 to 3 lb).

7. Containers

7.1 Type of Containers:

7.1.1 Containers for liquid bituminous materials, except emulsions, shall be wide-mouth cans with lined screw caps or triple-seal friction-top cans.

7.1.2 Containers for emulsified bituminous materials shall be wide-mouth jars or bottles made of plastic, or wide-mouth plastic-lined cans with lined screw caps, or plastic-lined triple-seal friction-top cans.

7.1.3 Containers for crushed or powdered bituminous materials shall be triple-seal friction-top cans or plastic sacks placed in other containers suitable for handling.

7.2 Size of Containers:

7.2.1 The size of the container shall correspond to the required amount of sample.

8. Protection and Preservation of Samples

8.1 Sample containers shall be new. They shall not be washed or rinsed, or wiped with an oily cloth. If they contain

¹ This practice is under the jurisdiction of ASTM Committee D04 on Road and Paving Materials and is the direct responsibility of Subcommittee D04.30 on Methods of Sampling.

Current edition approved Jan. 10, 2000. Published April 2000. Originally published as D 140 – 22 T. Last previous edition D 140 – 98.

² *Annual Book of ASTM Standards*, Vol 05.05.

evidence of solder flux, or if they are not clean and dry, they shall not be used. Top and container shall fit together tightly.

8.2 Care shall be taken to prevent the sample from becoming contaminated. Immediately after filling, the container shall be tightly and positively sealed.

8.3 The filled sample container shall not be submerged in solvent, nor shall it be wiped with a solvent saturated cloth. If cleaning is necessary use a clean dry cloth.

8.4 Samples of emulsions shall be protected from freezing by correct packaging.

NOTE 1—When sampling emulsions, care should be taken not to sample material under pressure as such resultant velocities tend to cause air entrapment which could result in erroneous test results. Any visual bubbling of the material is one indication air has been entrapped. In addition, the sampling container should be completely filled to minimize a skin formation at the air-emulsion interface.

8.5 Samples shall not be transferred from one container to another except where required by the sampling procedure.

8.6 Immediately after filling, sealing, and cleaning, the sampling containers shall be properly marked for identification with a suitable marking pencil on the container itself, not on the lid. Linen tags also may be used for identification if they can be securely fastened to the container in such a manner as to ensure that they will not be lost in transit. Linen tags shall not be attached to containers by using the lids to secure them.

9. Sampling at Place of Manufacture

9.1 *Vertical Tanks Not Capable of Being Agitated (Liquid Materials or Materials Made Liquid by Heating)* (800 m³ (5000 bbl) or more capacity)—Three sampling methods are recommended (Note 2):

9.1.1 *Sampling-Valve Method*—Valves shall be located, with easy and safe access provided, on the side of the tank with the first in the top third of the tank, but no higher than 1 m (3 ft) from the top; the second in the middle third of the tank; and the third in the bottom third of the tank, but no lower than 1.1 m (3 ft) from the bottom. A recommended design of the sampling valve is shown in Fig. 1.

9.1.1.1 A minimum of 4 L (1 gal) of the product shall be drawn from each sample valve and discarded before taking the sample for test, and

9.1.1.2 One to 4 L (1 qt to 1 gal) shall be drawn from each sample valve for test.

9.1.2 *Thief Sampler Method* (not suitable for asphalt cements)—Samples shall be taken in the top, middle, and lower sections at levels indicated in 9.1.1, of the tank by lowering a thief sampler into the material. A satisfactory type with instructions for use is shown in Fig. 2.

NOTE 2—Most bituminous materials in the liquid state are of such viscous and adhesive character that, after normal emptying of a container by pouring, the container retains enough material to cause significant contamination of any second samples secured before the container was thoroughly cleaned. The aforementioned properties of bituminous materials also make container cleaning a difficult, tedious, and time-consuming task.

NOTE 3—The thief sampler described in Fig. 2 may be used for repetitive sampling because significant sample contamination by previous contents is avoided by the self-cleaning action provided by the passage of material through the tube-shaped thief sampler which is open at both ends. The practice of raising and lowering the sampler 3 or 4 times through a

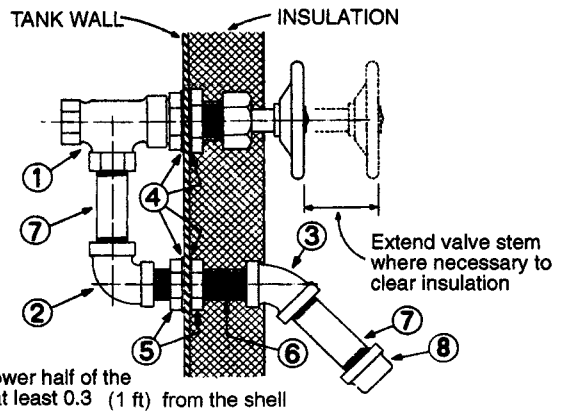

REF. NO.	DESCRIPTION	NO. REQ.
1	20 MM (3/4 IN.) 'VOGT' P-9844 STEEL ANGLE VALVE OR SIMILAR, PANEL MOUNTED	1
2	20 MM (3/4 IN.) STEEL OR MALL. IRON 1.6 RAD ELBOW	1
3	20 MM (3/4 IN.) STEEL OR MALL. IRON 0.8 RAD ELBOW	1
4	ASBESTOS GASKETS SNUG ON THREAD OR WOUND WITH YARN	4
5	20 MM (3/4 IN.) 150# SCREWED M.I. LOCKNUT	2
6	20 X 90 MM (3/4 X 3 1/2 IN.) ± PARALLEL THREADED STEEL PIPE NIPPLE (CUT FROM 20 MM (3/4 IN.) STD. TANK NIPPLE IF OTHERWISE UNOBTAINABLE)	1
7	20 X 75 MM (3/4 X 3 IN.) THREADED STEEL PIPE NIPPLE	2
8	20 MM (3/4 IN.) MALL. IRON PIPE CAP	1

FIG. 1 Typical Submerged Sampling Device

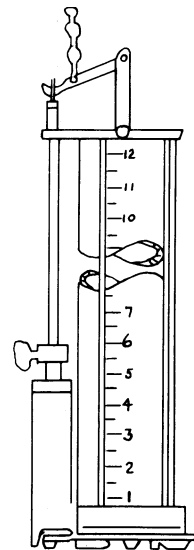

FIG. 2 Thief Sampler

distance of a metre (several feet) at the sampling depth is recommended.

9.1.3 *Throw-Away Container Method*—Samples shall be taken at top, middle, and lower levels by lowering into the

material a container in a suitable weighted holding device. The essential feature of the method is to use a clean container to take the sample, pour this sample into another clean container, and throw away the container used to take the sample from the tank. A satisfactory type with instructions on how to use the device is shown in Fig. 3.

9.1.4 The three samples from bulk storage tanks may be tested separately for consistency to detect stratification. They may be combined, thoroughly mixed, and a 1 to 4-L (1-qt to 1-gal) sample may be taken for other tests that may be required for determining average characteristics of the material.

9.2 *Bulk Storage Tanks (Liquid Materials or Materials Made Liquid by Heating) Equipped with Mechanical Agitators*—When the tank is equipped with operating mechanical agitators which, by observation through the sampling or inspection hatch, are performing adequate mixing of the tank contents, a single sample taken by any of the methods described in 9.1.1, 9.1.2, or 9.1.3 will be satisfactory to use for test purposes.

10. Sampling from Tank Cars, Vehicle Tanks, Distributor Trucks or Recirculating Storage Tanks

10.1 The sample may be taken from the sample valve or tap if the tanks are provided with them. When such sampling devices are required, they are to be built into the tank itself. A sampling device of this type is shown in Fig. 1. Before the sample is taken, 4 L (1 gal) shall be drawn from the sample valve and discarded.

10.2 Samples of liquid materials and materials made liquid by heating may be taken by the dip method using a clean wide-mouth or friction-top can in a suitable holder as shown in Fig. 4. A clean container must be used to take each sample, and the material sampled shall then be transferred to another new and clean container for retention or testing sample.

10.3 A detachable fitting, similar in design to the one shown in Fig. 5 may be inserted in the discharge line. Before the sample is taken 4 L (1 gal) shall be drawn from this sampling valve and discarded.

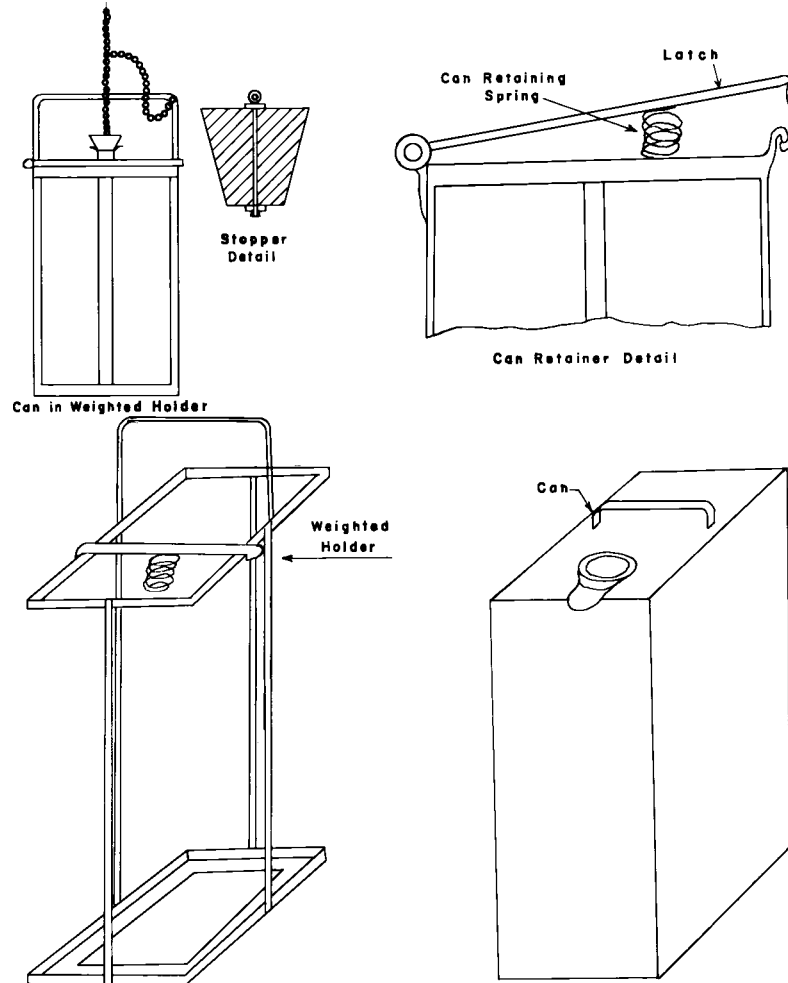

NOTE 1—This type sampler is lowered into the tank with the stopper in place. When the desired depth is reached, the stopper is removed by means of the attached wire, cord, or chain and the container allowed to fill. Complete filling is indicated by the cessation of bubbles of air from the can at the surface of the liquid. The sampler is then withdrawn from the tank and the contents poured into the clean sampler container. A clean can (bottle) must be used for each sample taken.

FIG. 3 Throw-Away Container Sampler

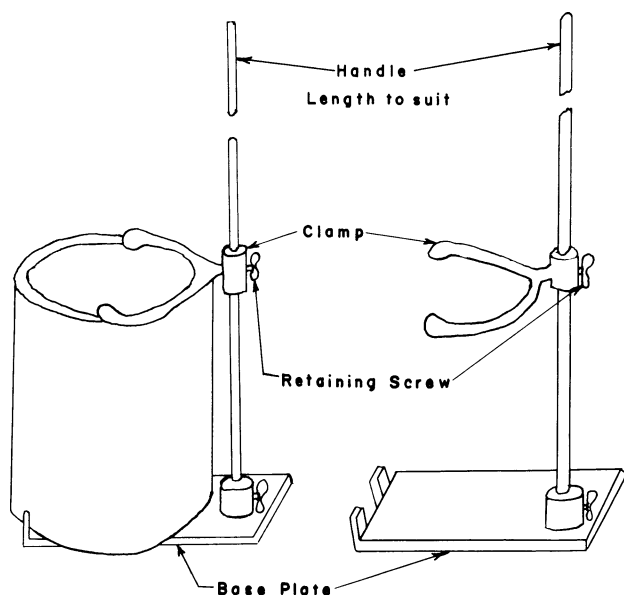

NOTE 1—Sampler with can secured in place is rapidly lowered into tank to desired depth and allowed to fill with sample. The sampler is then withdrawn from the tank and the contents transferred to the sample container. A clean container *must* be used to take each sample.

FIG. 4 Dip Sampler

11. Sampling from Tankers and Barges

11.1 For liquid materials (including all cut-backs made liquid by heating) top, middle, and lower samples shall be taken using the methods as described in 9.1.2 and 9.1.3.

11.2 For all other materials made liquid by heating, a top sample only shall be taken by the dip, thief, or throw-away container method.

12. Sampling from Pipe Lines During Loading or Unloading

12.1 When tankers and barges are being loaded or unloaded samples may conveniently be taken from the pipe line through which the material is flowing by insertion of a sampling pipe into a rising section of the pipe line on the discharge side of the pump or in a completely filled line in which gravity creates the materials flow. A suitable in-line sampling pipe is shown in Fig. 5. The sampling pipe shall be not more than one eighth the diameter of the pipe line and its opening should be turned to face the flow of the liquid. This pipe shall be provided with a valve or plug cock and shall discharge into a sample receiver. At least three 4-L (1-gal) samples shall be taken at uniform intervals throughout the entire loading or unloading. At the completion of the loading or unloading, the individual 4-L samples shall be combined, thoroughly mixed without altering its characteristics, and a 4-L sample taken therefrom.

12.2 When sampling tankers and barges 4000 m³ (25 000 bbl), or less, capacity, at least five 4-L (1-gal) samples shall be taken at uniform intervals throughout the entire loading or unloading (4000 m³), or larger, capacity requires at least ten 4-L samples). At completion of the loading or unloading the individual 4-L samples shall be combined, thoroughly mixed in a manner designed to not alter its characteristics, and a 4-L sample taken therefrom.

13. Sampling from Drums or Barrels

13.1 After thorough mixing, samples of liquid bituminous material from barrels or drums shall be secured by tube or thief sampling by taking 1 L (1 qt) of material from packages selected at random according to Section 14.

14. Sampling Semisolid or Uncrushed Solid Materials

14.1 *Drums, Barrels, Cartons, and Bags*—Where the lot of material to be sampled is obviously from a single run or batch of the producer, one package shall be selected at random and sampled as described below. Where the lot of material to be sampled is not obviously from a single run or batch of the producer, or where the single samples selected as described above fails on test to conform to the requirements of the specifications, a number of packages shall be selected at random equivalent to the cube root of the total number of packages in the lot. The following table is given, showing the number of samples to be selected for shipments of various sizes.

Packages in Shipment	Packages Selected
2 to 8	2
9 to 27	3
28 to 64	4
65 to 125	5
126 to 216	6
217 to 343	7
344 to 512	8
513 to 729	9
730 to 1000	10
1001 to 1331	11

Samples shall be taken from at least 75 mm (3 in.) below the surface and at least 75 mm from the side of the container. A clean hatchet may be used if the material is hard enough to shatter and a broad, stiff putty knife if the material is soft. When more than one package in a lot is sampled, each individual sample shall have a mass of not less than 0.1 kg (¼ lb) in weight. When the lot of material is obviously from a single run or batch of the producer, all samples from the lot shall be melted and thoroughly mixed, and an average 4-L (1-gal) sample taken from the combined material for examination. In case more than a single run or batch of the producer is present and the batches can be clearly differentiated, a composite 4-L sample shall be prepared for examination from each batch. Where it is not possible to differentiate between the various batches, each sample shall be examined separately.

15. Sampling Crushed or Powdered Materials

15.1 *Bulk Storage*—Solid bituminous materials in crushed fragments or powder shall be sampled in accordance with Practice D 346. The gross sample shall be not less than 25 kg (50 lb) from which shall be selected the 1 to 2-kg (2 to 3-lb) sample for test.

15.2 *Drums, Barrels, Bags and Cartons*—Where the crushed or powdered material is in barrels, drums, or bags, a number of packages shall be selected at random as described in Section 14. A sample at least 0.5 kg (1½ lb) in mass shall be selected from near the center of each container to yield a gross sample weighing not less than 25 kg (50 lb) from which the 1 to 2-kg (2 to 3-lb) sample for test shall be selected as prescribed in Practice D 346.



FIG. 5 In-Line Asphalt Sampling Device

16. Sampling at Point of Shipment Delivery

16.1 Sampling of bituminous materials shall be done as soon as practicable after the bituminous material has arrived at plant site, storage site, or job destination or at the time of unloading.

16.2 The required number of samples shall be taken from each delivery of bituminous material. In the case of small delivery units such as distributors, the samples shall be taken to represent a maximum of 40 m³ (10 000 gal).

16.3 Sampling shall be done by one of the three following methods:

16.3.1 In accordance with Section 9.

16.3.2 By bleeding through a sample valve or tap in the

transfer line during the unloading of the approximate middle third of the load, or

16.3.3 By means of a sampling device inserted to a level of approximately the middle third of the load or tank.

16.4 Tests for material acceptability shall be made on one of the samples taken. The other samples are to be retained for confirmation in the event the first sample tested should fail to comply with requirements.

17. Keywords

17.1 bituminous materials; crushed materials; liquid asphalts; powdered materials; sampling; semisolid materials; uncrushed solid materials

The American Society for Testing and Materials takes no position respecting the validity of any patent rights asserted in connection with any item mentioned in this standard. Users of this standard are expressly advised that determination of the validity of any such patent rights, and the risk of infringement of such rights, are entirely their own responsibility.

This standard is subject to revision at any time by the responsible technical committee and must be reviewed every five years and if not revised, either reapproved or withdrawn. Your comments are invited either for revision of this standard or for additional standards and should be addressed to ASTM Headquarters. Your comments will receive careful consideration at a meeting of the responsible technical committee, which you may attend. If you feel that your comments have not received a fair hearing you should make your views known to the ASTM Committee on Standards, at the address shown below.

This standard is copyrighted by ASTM, 100 Barr Harbor Drive, PO Box C700, West Conshohocken, PA 19428-2959, United States. Individual reprints (single or multiple copies) of this standard may be obtained by contacting ASTM at the above address or at 610-832-9585 (phone), 610-832-9555 (fax), or service@astm.org (e-mail); or through the ASTM website (www.astm.org).