



Designation: D 2171 – 01



Designation: 222/84 (89)

## Standard Test Method for Viscosity of Asphalts by Vacuum Capillary Viscometer<sup>1</sup>

This standard is issued under the fixed designation D 2171; the number immediately following the designation indicates the year of original adoption or, in the case of revision, the year of last revision. A number in parentheses indicates the year of last reapproval. A superscript epsilon ( $\epsilon$ ) indicates an editorial change since the last revision or reapproval.

*This standard has been approved for use by agencies of the Department of Defense.*

*This test method has been approved by the sponsoring committees and accepted by the cooperating societies in accordance with established procedures.*

### 1. Scope

1.1 This test method covers procedures for the determination of viscosity of asphalt (bitumen) by vacuum capillary viscometers at 60°C (140°F). It is applicable to materials having viscosities in the range from 0.0036 to over 20 000 Pa · s (0.036 to over 200 000 P).

NOTE 1—This test method is suitable for use at other temperatures, but the precision is based on determinations on asphalt cements at 60°C (140°F).

1.2 *This standard does not purport to address all of the safety concerns, if any, associated with its use. It is the responsibility of the user of this standard to establish appropriate safety and health practices and determine the applicability of regulatory limitations prior to use.*

### 2. Referenced Documents

#### 2.1 ASTM Standards:

E 1 Specification for ASTM Thermometers<sup>2</sup>

E 11 Specification for Wire-Cloth and Sieves for Testing Purposes<sup>3</sup>

E 77 Test Method for Inspection and Verification of Thermometers<sup>2</sup>

### 3. Terminology

#### 3.1 Definitions:

3.1.1 *Newtonian liquid*—a liquid in which the rate of shear is proportional to the shearing stress. The constant ratio of the

shearing stress to the rate of shear is the viscosity of the liquid. If the ratio is not constant, the liquid is non-Newtonian.

3.1.2 *viscosity*—the ratio between the applied shear stress and rate of shear is called the coefficient of viscosity. This coefficient is thus a measure of the resistance to flow of the liquid. It is commonly called the viscosity of the liquid. The SI unit of viscosity is 1 Pa · s (1 N·s/m<sup>2</sup>) and is called a Pascal-second. The cgs unit of viscosity is 1 g/cm·s (1 dyne·s/cm<sup>2</sup>) and is called a poise (P). 1 Pa · s is equivalent to 10 P.

### 4. Summary of Test Method

4.1 The time is measured for a fixed volume of the liquid to be drawn up through a capillary tube by means of vacuum, under closely controlled conditions of vacuum and temperature. The viscosity in Pascal-seconds is calculated by multiplying the flow time in seconds by the viscometer calibration factor.

NOTE 2—The rate of shear decreases as the liquid moves up the tube, or it can also be varied by the use of different vacuum or different size viscometer. Thus, this method is suitable for the measurement of viscosities of Newtonian (simple) and non-Newtonian (complex) liquids.

### 5. Significance and Use

5.1 The viscosity at 60°C (140°F) characterizes flow behavior and may be used for specification requirements for cutbacks and asphalt cements.

### 6. Apparatus

6.1 *Viscometers*, capillary-type, made of borosilicate glass, annealed, suitable for this test are as follows:

6.1.1 *Cannon-Manning Vacuum Viscometer (CMVV)*, as described in Appendix X1.

6.1.2 *Asphalt Institute Vacuum Viscometer (AIVV)*, as described in Appendix X2.

<sup>1</sup> This test method is under the jurisdiction of ASTM Committee D04 on Road and Paving Materials and is the direct responsibility of Subcommittee D04.44 on Rheological Tests. In the IP this test method is under the jurisdiction of the Standardization Committee.

Current edition approved Aug. 10, 2001. Published October 2001. Originally published as D 2171 – 63 T. Last previous edition D 2171 – 94.

<sup>2</sup> *Annual Book of ASTM Standards*, Vol 14.03.

<sup>3</sup> *Annual Book of ASTM Standards*, Vol 14.02.

6.1.3 *Modified Koppers Vacuum Viscometer (MKVV)*, as described in Appendix X3. Calibrated viscometers are available from commercial suppliers. Details regarding calibration of viscometers are given in Appendix X4.

NOTE 3—The viscosity measured in a CMVV may be from 1 to 5 % lower than either the AIVV or MKVV having the same viscosity range. This difference, when encountered, may be the result of non-Newtonian flow.<sup>4</sup>

6.2 *Thermometers*— Calibrated liquid-in-glass thermometers (see Table X5.1) of an accuracy after correction of 0.02°C (0.04°F) can be used or any other thermometric device of equal accuracy. ASTM Kinematic Viscosity Thermometers 47°C and 47°F are suitable for the most commonly used temperature of 60°C (140°F).

6.2.1 The specified thermometers are standardized at “total immersion,” which means immersion to the top of the mercury column with the remainder of the stem and the expansion chamber at the top of the thermometer exposed to room temperature. The practice of completely submerging the thermometer is not recommended. When thermometers are completely submerged, corrections for each individual thermometer based on calibration under conditions of complete submergence must be determined and applied. If the thermometer is completely submerged in the bath during use, the pressure of the gas in the expansion chamber will be higher or lower than during standardization, and may cause high or low readings on the thermometer.

6.2.2 It is essential that liquid-in-glass thermometers be calibrated periodically using the technique given in Test Method E 77 (see Appendix X5).

6.3 *Bath*—A bath suitable for immersion of the viscometer so that the liquid reservoir or the top of the capillary, whichever is uppermost, is at least 20 mm below the upper surface of the bath liquid and with provisions for visibility of the viscometer and the thermometer. Firm supports for the viscometer shall be provided. The efficiency of the stirring and the balance between heat losses and heat input must be such that the temperature of the bath medium does not vary by more than ±0.03°C (±0.05°F) over the length of the viscometer, or from viscometer to viscometer in the various bath positions.

6.4 *Vacuum System*— A vacuum system<sup>5</sup> capable of maintaining a vacuum to within ±0.5 mm of the desired level up to and including 40.0 kPa 300 mm Hg. The essential system is shown schematically in Fig. 1. Glass tubing of 6.35-mm (¼-in.) inside diameter should be used, and all glass joints should be airtight so that when the system is closed, no loss of vacuum is indicated by the open-end mercury manometer having 1-mm graduations. A vacuum or aspirator pump is suitable for the vacuum source.

6.5 *Timer*—A stop watch or other timing device graduated in divisions of 0.1 s or less and accurate to within 0.05 % when tested over intervals of not less than 15 min.

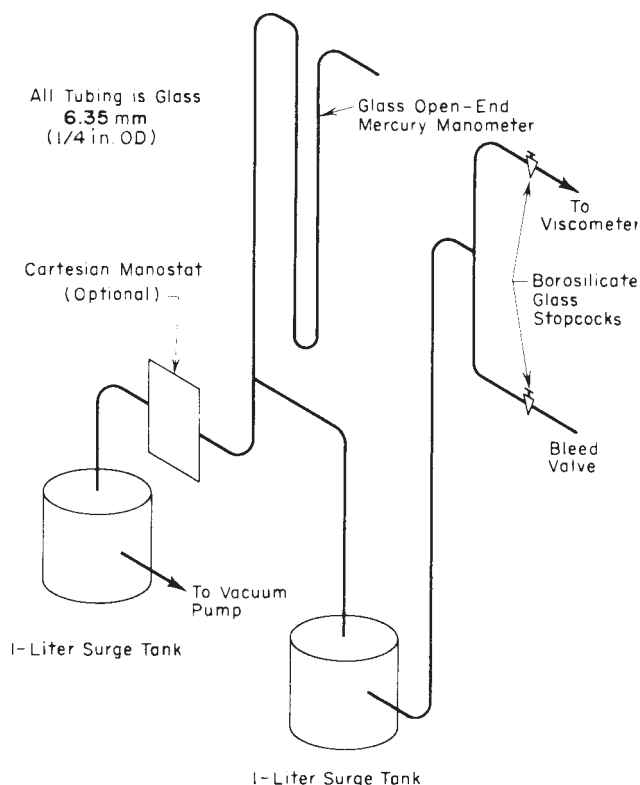

FIG. 1 Suggested Vacuum System for Vacuum Capillary Viscometers

6.6 *Electrical Timing Devices* may be used only on electrical circuits, the frequencies of which are controlled to an accuracy of 0.05 % or better.

6.6.1 Alternating currents, the frequencies of which are intermittently and not continuously controlled, as provided by some public power systems, can cause large errors, particularly over short timing intervals, when used to actuate electrical timing devices.

## 7. Sample Preparations

7.1 Heat the sample with care to prevent local overheating until it has become sufficiently fluid to pour, occasionally stirring the sample to aid heat transfer and to assure uniformity.

7.2 Transfer a minimum of 20 mL into a suitable container and heat to 135 ± 5.5°C (275 ± 10°F), stirring occasionally to prevent local overheating and taking care to avoid the entrapment of air.

NOTE 4—If it is suspected that the sample may contain solid material, strain the melted sample into the container through a No. 50 (300-µm) sieve conforming to No. 50 Specification E 11.

## 8. Procedure

8.1 The specific details of operation vary somewhat for the various types of viscometers. See the detailed descriptions of viscometers in Appendix X1-Appendix X3 for instructions for using the type of viscometer selected. In all cases, however, follow the general procedure described in 8.1.1-8.1.9.

8.1.1 Maintain the bath at the test temperature within ± 0.03°C (0.05°F). Apply the necessary corrections, if any, to all thermometer readings.

<sup>4</sup> Supporting data are available from ASTM Headquarters, 100 Barr Harbor Drive, West Conshohocken, PA 19428-2959. Request RR:D04-1003.

<sup>5</sup> The vacuum control system marketed by Cannon Instrument Co., P. O. Box 16, State College, PA 16801, has been found satisfactory for this purpose.

8.1.2 Select a clean, dry viscometer that will give a flow time greater than 60 s, and preheat to  $135 \pm 5.5^\circ\text{C}$  ( $275 \pm 10^\circ\text{F}$ ).

8.1.3 Charge the viscometer by pouring the prepared sample to within  $\pm 2$  mm of fill line E (Fig. 2, Fig. 3, and Fig. 4).

8.1.4 Place the charged viscometer in an oven or bath maintained at  $135 \pm 5.5^\circ\text{C}$  ( $275 \pm 10^\circ\text{F}$ ) for a period of  $10 \pm 2$  min, to allow large air bubbles to escape.

8.1.5 Remove the viscometer from the oven or bath and, within 5 min, insert the viscometer in a holder, and position the viscometer vertically in the bath so that the upper most timing mark is at least 20 mm below the surface of the bath liquid.

8.1.6 Establish a  $40.0 \pm 0.07$  kPa ( $300 \pm 0.5$  mm Hg) vacuum below atmospheric pressure in the vacuum system and connect the vacuum system to the viscometer with the toggle valve or stopcock closed in the line leading to the viscometer.

8.1.7 After the viscometer has been in the bath for  $30 \pm 5$  min, start the flow of asphalt in the viscometer by opening the toggle valve or stopcock in the line leading to the vacuum system.

8.1.8 Measure to within 0.1 s the time required for the leading edge of the meniscus to pass between successive pairs of timing marks. Report the first flow time which exceeds 60 s between a pair of timing marks, noting the identification of the pair of timing marks.

8.1.9 Upon completion of the test, clean the viscometer thoroughly by several rinsings with an appropriate solvent completely miscible with the sample, followed by a completely

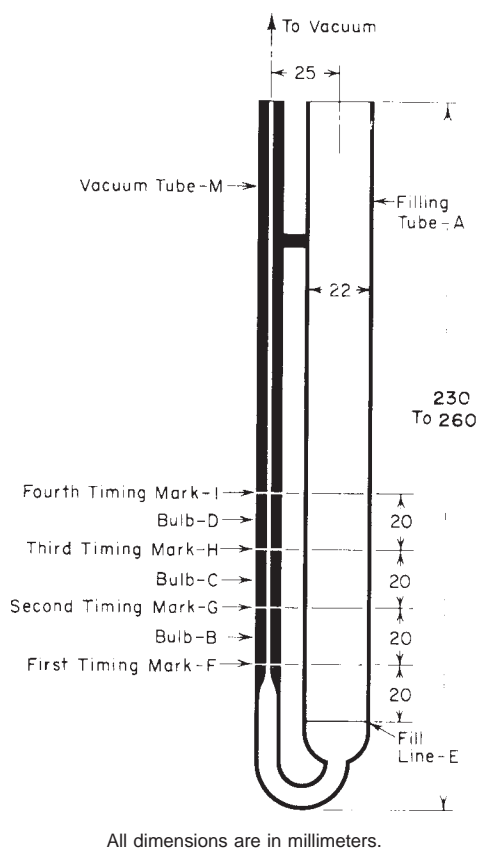

FIG. 3 Asphalt Institute Vacuum Capillary Viscometer

volatile solvent. Dry the tube by passing a slow stream of filtered dry air through the capillary for 2 min, or until the last trace of solvent is removed. Alternatively, the viscometer may be cleaned in a glass-cleaning oven, at a temperature not to exceed  $500^\circ\text{C}$  ( $932^\circ\text{F}$ ), followed by rinses with distilled or deionized water, residue-free acetone, and filtered dry air. Periodically clean the instrument with a strong acid cleaning solution to remove organic deposits, rinse thoroughly with distilled water and residue-free acetone, and dry with filtered dry air.

8.1.9.1 Chromic acid cleaning solution may be prepared by adding, with the usual precautions, 800 mL of concentrated sulphuric acid to a solution of 92 g of sodium dichromate in 458 mL of water. The use of similar commercially available sulphuric acid cleaning solutions is acceptable. Nonchromium-containing, strongly oxidizing acid cleaning solutions<sup>6</sup> may be substituted so as to avoid the disposal problems of chromium-containing solutions.

8.1.9.2 Use of alkaline glass cleaning solutions may result in a change of viscometer calibration, and is not recommended.

## 9. Calculation

9.1 Select the calibration factor that corresponds to the pair of timing marks used for the determination, as prescribed in

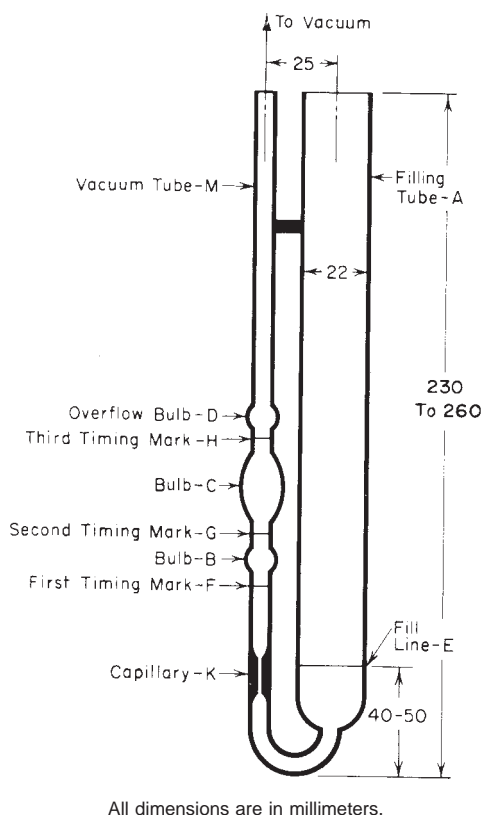

FIG. 2 Cannon-Manning Vacuum Capillary Viscometer

<sup>6</sup> A commercial source for a nonchromium-containing cleaning solution is Godax Laboratories Inc., 480 Canal St., New York, NY 10013.

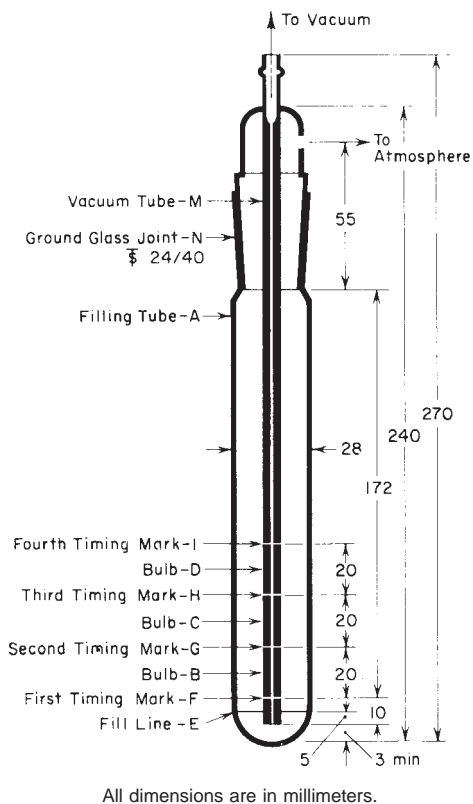

FIG. 4 Modified Koppers Vacuum Capillary Viscometer

8.1.8. Calculate and report the viscosity to three significant figures using the following equation:

$$\text{Viscosity, } Pa \cdot s = (Kt) \tag{1}$$

where:

- $K$  = selected calibration factor,  $Pa \cdot s/s$ , and
- $t$  = flow time, s.

NOTE 5—If the viscometer constant or calibration factor ( $K_{cgs}$ ) is known in cgs units (Poise/s) calculate the calibration factor (Ksi) in SI units (pascal-seconds/second) as follows:

$$Ksi = (Pa \cdot s/s) = K_{cgs}/10 \text{ or } (P/s)/10 \tag{2}$$

### 10. Report

10.1 Always report the test temperature and vacuum with the viscosity test result. For example, viscosity at 60°C (140°F) and 300 mm Hg vacuum, in  $Pa \cdot s$ .

### 11. Precision and Bias

11.1 The following criteria (see Note 1) should be used for judging the acceptability of results (95 % probability):

11.1.1 *Repeatability*— Duplicate results by the same operator using the same viscometer should not be considered suspect unless they differ by more than 7 % of their mean.

11.1.2 *Reproducibility*— The results submitted by each of two laboratories should not be considered suspect unless the two results differ by more than 10 % of their mean.

## APPENDIXES

(Nonmandatory Information)

### X1. CANNON-MANNING VACUUM CAPILLARY VISCOMETER (CMVV)

#### X1.1 Scope

X1.1.1 The Cannon-Manning vacuum capillary viscometer (CMVV)<sup>7,8</sup> is available in eleven sizes (Table X1.1) covering a range from 0.0036 to 8 000  $Pa \cdot s$  (0.036 to 80 000 P). Sizes 10 through 14 are best suited to viscosity measurements of asphalt cements at 60°C (140°F).

#### X1.2 Apparatus

X1.2.1 Details of the design and construction of Cannon-Manning vacuum capillary viscometers are shown in Fig. 2. The size numbers, approximate bulb factors,  $K$ , and viscosity ranges for the series of Cannon-Manning vacuum capillary viscometers are given in Table X1.1.

X1.2.2 For all viscometer sizes, the volume of measuring bulb C is approximately three times that of bulb B.

TABLE X1.1 Standard Viscometer Sizes, Approximate Calibration Factors,  $K$  and Viscosity Ranges for Cannon-Manning Vacuum Capillary Viscometers

Viscometer Size Number	Approximate Calibration Factor, $K$ , <sup>A</sup> 40 kPa (300 mm Hg) Vacuum, $Pa \cdot s/s$ (P/s/10)		Viscosity Range, $Pa \cdot s$ <sup>B</sup>	Viscosity Range, P <sup>B</sup>
	Bulb B	Bulb C		
	4	0.0002		
5	0.0006	0.0002	0.012 to 0.24	0.12 to 2.4
6	0.002	0.0006	0.036 to 0.8	0.36 to 8
7	0.006	0.002	0.12 to 2.4	1.2 to 24
8	0.02	0.006	0.36 to 8	3.6 to 80
9	0.06	0.02	1.2 to 24	12 to 240
10	0.2	0.06	3.6 to 80	36 to 800
11	0.6	0.2	12 to 240	120 to 2 400
12	2.0	0.6	36 to 80	360 to 8
13	6.0	2.0	120 to 2 400	1 200 to 24 000
14	20.0	6.0	360 to 8 000	3 600 to 80 000

<sup>A</sup> Exact calibration factors must be determined with viscosity standards.

<sup>B</sup> The viscosity ranges shown in this table correspond to a filling time of 60 to 400 s. Longer flow times (up to 1000 s) may be used.

<sup>7</sup> Griffith, J. M. and Puzinauskas, P., "Relation of Empirical Tests to Fundamental Viscosity of Asphalt Cement and the Relative Precision of Data Obtained by Various Tests Methods," *Symposium on Fundamental Viscosity of Bituminous Materials, ASTM STP 328*, Am. Soc. Testing Mats., ASTTA, 1962, pp. 20–44.

<sup>8</sup> Manning, R. E., "Comments on Vacuum Viscometers for Measuring the Viscosity of Asphalt Cements," *Symposium on Fundamental Viscosity of Bituminous Materials, ASTM STP No. 328*, Am. Soc. Testing Mats., ASTTA, 1962, pp. 44–47.

X1.2.3 A convenient holder can be made by drilling two holes, 22 and 8 mm in diameter, respectively, through a No. 11

rubber stopper. The center-to-center distance between holes should be 25 mm. Slit through the rubber stopper between holes and also between the 8-mm hole and edge of the stopper.

When placed in a 51-mm (2-in.) diameter hole in the bath cover, the stopper holds the viscometer in place. Such holders are commercially available.

## X2. ASPHALT INSTITUTE VACUUM CAPILLARY VISCOMETER (AIVV)

### X2.1 Scope

X2.1.1 The Asphalt Institute vacuum capillary viscometer (AIVV)<sup>7,8</sup> is available in seven sizes (Table X2.1) from a range from 4.2 to 580 000 Pa · s (42 to 5 800 000 P). Sizes 50 through 200 are best suited to viscosity measurements of asphalt cements at 60°C (140°F).

### X2.2 Apparatus

X2.2.1 Details of design and construction of the Asphalt Institute vacuum capillary viscometer are shown in Fig. 3. The size numbers, approximate radii, approximate bulb factors, *K*, and viscosity range for the series of Asphalt Institute vacuum capillary viscometers are given in Table X2.1.

X2.2.2 This viscometer has measuring bulbs, *B*, *C*, and *D*, located on the viscometer arm, *M*, which is a precision bore glass capillary. The measuring bulbs are 20-mm long capillary segments, separated by timing marks, *F*, *G*, *H*, and *I*.

X2.2.3 A convenient holder can be made by drilling two holes, 22 and 8 mm in diameter, respectively, through a No. 11 rubber stopper. The center-to-center distance between holes should be 25 mm. Slit through the rubber stopper between the holes and also between the 8-mm hole and edge of the stopper. When placed in a 51-mm (2-in.) diameter hole in the bath cover, the stopper holds the viscometer in place. Such holders are commercially available.

**TABLE X2.1 Standard Viscometer Sizes, Capillary Radii, Approximate Calibration Factors, *K*, and Viscosity Ranges for Asphalt Institute Vacuum Capillary Viscometers**

Viscometer Size Number	Capillary Radius, mm	Approximate Calibration Factor, <i>K</i> , <sup>A</sup> 40 kPa (300 mm) Hg Vacuum, Pa · s/s (P/s)/10			Viscosity Range, Pa · s <sup>B</sup>	Viscosity Range, P <sup>B</sup>	
		Bulb B	Bulb C	Bulb D			
25	0.125	0.2	.1	0.07	4.2 to 80	42 to	800
50	0.25	0.8	.4	.3	18 to 320	180 to	3 200
100	0.50	3.2	1.6	1.0	60 to 1 280	600 to	12 800
200	1.0	12.8	6.4	4.0	240 to 5 200	2 400 to	52 000
400	2.0	50.0	25.0	16.0	960 to 20 000	9 600 to	200 000
400R <sup>C</sup>	2.0	50.0	25.0	16.0	960 to 140 000	9 600 to 1	400 000
800R <sup>C</sup>	4.0	200.0	100.0	64.0	3 800 to 580 000	38 000 to 5	800 000

<sup>A</sup> Exact calibration factors must be determined with viscosity standards.

<sup>B</sup> The viscosity ranges shown in this table correspond to a filling time of 60 to 400 s. Longer flow times (up to 1000 s) may be used.

<sup>C</sup> Special design for roofing asphalts having additional marks at 5 and 10 mm above timing mark, *F* (see Fig. 3). Thus, using these marks, the maximum viscosity range is increased from that using the bulb B calibration factor.

### X3. MODIFIED KOPPERS VACUUM CAPILLARY VISCOMETER (MKVV)

#### X3.1 Scope

X3.1.1 The Modified Koppers vacuum capillary viscometer (MKVV)<sup>9,10,11</sup> is available in five sizes (Table X3.1) covering a range from 4.2 to 20 000 Pas (42 to 2000 000). Sizes 50 through 200 are best suited to viscosity measurements of asphalt cements at 60°C (140°F).

#### X3.2 Apparatus

X3.2.1 Details of design and construction of the Modified Koppers vacuum capillary viscometer are shown in Fig. 4. The

size numbers, approximate radii, approximate bulb factors, *K*, and viscosity ranges for the series of Modified Koppers vacuum capillary viscometers are given in Table X3.1.

X3.2.2 This viscometer consists of a separate filling tube, *A*, and precision-bore glass capillary vacuum tube, *M*. These two parts are joined by a borosilicate ground glass joint, *N*, having a 24/40 standard taper. The measuring bulbs *B*, *C*, and *D*, on the glass capillary are 20-mm long capillary segments, separated by timing marks *F*, *G*, *H*, and *I*.

X3.2.3 A viscometer holder can be made by drilling a 28-mm hole through the center of a No. 11 rubber stopper and slitting the stopper between the hole and the edge. When placed in a 51-mm (2-in.) diameter hole in the bath cover, it holds the viscometer in place.

<sup>9</sup> Rhodes, E. O., Volkman, E. W., and Barker, C. T., "New Viscometer for Bitumens Has Extended Range," *Engineering News-Record*, Vol 115, No. 21, 1935, p. 714.

<sup>10</sup> Lewis, R. H. and Halstead, W. J., "Determination of the Kinematic Viscosity of Petroleum Asphalts with a Capillary Tube Viscometer," *Public Roads*, Vol 21, No. 7, September 1940, p. 127.

<sup>11</sup> Heithaus, J. J., "Measurement of Asphalt Viscosity with a Vacuum Capillary Viscometer," *Papers on Road and Paving Materials and Symposium on Microviscometry*, ASTM STP 309, 1961, p. 63.

**TABLE X3.1 Standard Viscometer Sizes, Capillary Radii, Approximate Calibration Factors, *K*, and Viscosity Ranges for Asphalt Institute Vacuum Capillary Viscometers**

Viscometer Size Number	Capillary Radius, mm	Approximate Calibration Factor, <i>K</i> , <sup>A</sup> 40 kPa (300 mm) Hg Vacuum, Pa · s/s (P/s)/10			Viscosity Range, Pa · s <sup>B</sup>	Viscosity Range, Pa · s <sup>B</sup>
		Bulb B	Bulb C	Bulb D		
25	0.125	0.2	0.1	.007	4.2 to 80	42 to 800
50	0.25	0.8	0.4	0.3	18 to 320	180 to 3 200
100	0.50	3.2	1.6	1.0	60 to 1 280	600 to 12 800
200	1.0	12.8	6.4	4.0	240 to 5 200	2 400 to 52 000
400	2.0	50.0	25.0	16.0	960 to 20 000	9 600 to 200 000

<sup>A</sup> Exact calibration factors must be determined with viscosity standards.

<sup>B</sup> The viscosity ranges shown in this table correspond to a filling time of 60 to 400 s. Longer flow times (up to 100 s) may be used.

## X4. CALIBRATION OF VISCOMETERS

### X4.1 Scope

X4.1.1 This appendix describes the materials and procedures used for calibrating or checking the calibration of viscometers used in this method.

### X4.2 Reference Materials

X4.2.1 *Viscosity Standards* having approximate viscosities are given in Table X4.1.

### X4.3 Calibration

X4.3.1 *Calibration of Vacuum Viscometer by Means of Viscosity Standards*—Calibrate the vacuum viscometer as follows:

X4.3.1.1 Select from Table X4.1 a viscosity standard having a minimum flow time of 60 s at the calibration temperature.

X4.3.1.2 Charge a clean, dry viscometer by pouring the sample to within  $\pm 2$  mm of fill line *E* (See Fig. 2, Fig. 3, and Fig. 4).

X4.3.1.3 Place the charged viscometer in the viscometer bath, maintained at the calibration temperature  $\pm 0.01^\circ\text{C}$  ( $\pm 0.02^\circ\text{F}$ ).

X4.3.1.4 Establish a  $300 \pm 0.5$ -mm ( $40.0 \pm .07$  kPa) Hg vacuum in the vacuum system and connect the vacuum system to the viscometer with the toggle valve or stopcock closed in the line leading to the viscometer.

X4.3.1.5 After the viscometer has been in the bath for  $30 \pm 5$  min, start the flow of standard in the viscometer by opening the stopcock or toggle valve in the line leading to the vacuum system.

X4.3.1.6 Measure to within 0.1 s, the time required for the leading edge of the meniscus to pass between timing marks *F*

and *G*. Using a second timer, also measure to within 0.1 s, the time required for the leading edge of the meniscus to pass between timing marks *G* and *H*. If the instrument contains additional timing marks, similarly determine the flow time for each successive bulb.

X4.3.1.7 Calculate the calibration factor, *K*, for each bulb as follows:

$$K = \eta/t \quad (\text{X4.1})$$

where:

*K* = viscometer bulb calibration factor, (Pa · s/s) 40.0 kPa (300 mm),

$\eta$  = viscosity of viscosity standard at calibration temperature, P, and

*t* = flow time, s.

X4.3.1.8 Repeat the calibration procedure using the same viscosity standard or another viscosity standard. Record the average calibration constant, *K*, for each bulb.

NOTE X4.1—The duplicate determinations of calibration constant, *K*, for each bulb **must** agree with 2 % of their mean (Note X4.2).

NOTE X4.2—The bulb constants are independent of temperature.

X4.3.2 *Calibration of Vacuum Viscometer by Means of Standard Vacuum Viscometer*—Calibrate the vacuum viscometer as follows:

X4.3.2.1 Select any petroleum asphalt having a flow time of at least 60 s. Select also a standard viscometer of known bulb constants.

X4.3.2.2 Mount the standard viscometer together with the viscometer to be calibrated in the same bath at  $60^\circ\text{C}$  ( $140^\circ\text{F}$ ) and determine the flow times of the asphalt by the procedure described in 8.1.

X4.3.2.3 Calculate the constant, *K*, for each bulb as follows:

$$K_1 = (t_2 \times K_2)/t_1 \quad (\text{X4.2})$$

where:

*K*<sub>1</sub> = constant of viscometer bulb being calibrated,

*t*<sub>1</sub> = flow time of viscometer bulb being calibrated,

*K*<sub>2</sub> = bulb constant of standard viscometer, and

*t*<sub>2</sub> = flow time of corresponding bulb in standard viscometer.

**TABLE X4.1 Viscosity Standards**

Viscosity	Approximate Viscosity, Pa · s		Approximate Viscosity, P	
	At 20°C (68°F)	At 40°C (104°F)	At 20°C (68°F)	At 40°C (104°F)
N30000 <sup>A</sup>	150	21	1500	210
N190000 <sup>A</sup>	800	140	8000	1400
S30000 <sup>A</sup>	...	21	...	210

<sup>A</sup> Available in 1-pt containers. Purchase orders should be addressed to Cannon Instrument Co., P. O. Box 16, State College, PA 16801. Shipment will be made as specified or by best means.

## X5. ICE POINT DETERMINATION AND RECALIBRATION OF KINEMATIC VISCOSITY THERMOMETERS

X5.1 To achieve an accuracy of  $\pm 0.02^\circ\text{C}$  for calibrated kinematic viscosity thermometers, it is required that a check at the ice point be made and the corrections altered for the change seen in the ice point. It is recommended that the interval of checking be every six months; for a new thermometer, check monthly for the first six months.

X5.2 A detailed procedure for the measurement of the ice point and recalibration of thermometers is described in 6.5 of

Test Method E 77. The suggestions in the following sections of this appendix are given specifically for the mercury-in-glass kinematic viscosity thermometers described in Table X5.1, and may not apply to other thermometers.

X5.2.1 The ice point reading of kinematic viscosity thermometers shall be taken within 60 min after being at the test temperature for not less than 3 min. The ice point reading shall be expressed to the nearest  $0.01^\circ\text{C}$  or  $0.02^\circ\text{F}$ .

**TABLE X5.1 Kinematic Viscosity Test Thermometers<sup>A</sup>**

Test Temperature Scale Error <sup>B</sup>		Thermometer Number	
°C	°F	ASTM <sup>C</sup>	IP <sup>D</sup>
20 and 21.1	68 and 70	44C, F	29C, F
25	77	45C, F	30C, F
30	86	118C, F	...
37.8	100	28F	31C, F
40		120C	...
50	122	46C, F	66C, F
54.4	130	29F	34C, F
60	140	47C, F	35C, F
82.2	180	48F	90C, F
93.3	200	...	36C, F
98.9 and 100	210 and 212	30F	32C, F
100		121C	
135	275	110C, F	

<sup>A</sup> The smallest graduation of the Celsius thermometers is 0.05°C and for the Fahrenheit thermometers is 0.1°F.

<sup>B</sup> Scale error for the Celsius thermometers is not to exceed  $\pm 0.1^\circ\text{C}$  for the Fahrenheit thermometers it is  $\pm 0.2^\circ\text{F}$  (except for ASTM 110F which is  $\pm 0.3^\circ\text{F}$ ). These scale errors are required to apply only at the given test temperature.

<sup>C</sup> Complete construction detail is given in Specifications E 1.

<sup>D</sup> Complete construction detail is given in Part I of IP Standards for Petroleum and its Products.

X5.2.2 Select clear pieces of ice, preferably made from distilled or pure water. Discard any cloudy or unsound portions. Rinse the ice with distilled water and shave or crush into small pieces, avoiding direct contact with the hands or any chemically unclean objects. Fill the Dewar vessel with the crushed ice and add sufficient distilled and preferably pre-cooled water to form a slush, but not enough to float the ice. As the ice melts, drain off some of the water and add more crushed ice. Insert the thermometer packing the ice gently about the stem, to a depth approximately one scale division below the 0°C (32°F) graduation. It may be necessary to repack the ice around the thermometer because of melting.

X5.2.3 After at least 3 min have elapsed, tap the stem gently, and observe the reading. Successive readings taken at least 1 min apart should agree within one tenth of a division.

X5.2.4 Record the ice point reading and compare it with the previous reading. If the reading is found to be higher or lower than the reading corresponding to a previous calibration, readings at all other temperatures will be correspondingly increased or decreased.

X5.2.5 The ice point procedure given in X5.1-X5.2.4 is used for the recalibration of kinematic viscosity thermometers, and a complete new calibration of the thermometer is not necessary in order to meet the accuracy ascribed to this design thermometer.

X5.3 It is recommended that these kinematic viscosity thermometers be stored vertically when not in use so as to avoid the separation of the mercury column.

X5.4 It is recommended that these kinematic viscosity thermometers be read to the nearest  $\frac{1}{5}$  of a division using appropriate magnification. Since these thermometers are typically in a kinematic viscosity bath (which has vision through the front), the thermometer is read by lowering the thermometer such that the top of the mercury column is 5 to 15 mm below the surface of the bath liquid. Be careful to ensure that the expansion chamber at the top of the thermometer is above the lid of the constant temperature bath. If the expansion chamber is at elevated or lowered temperatures from ambient temperatures, a significant error can occur. This error can be as much as one or two thermometer divisions. A reading glass such as used for reading books may be useful to ensure reading the scale to  $\frac{1}{5}$  of a division.

*ASTM International takes no position respecting the validity of any patent rights asserted in connection with any item mentioned in this standard. Users of this standard are expressly advised that determination of the validity of any such patent rights, and the risk of infringement of such rights, are entirely their own responsibility.*

*This standard is subject to revision at any time by the responsible technical committee and must be reviewed every five years and if not revised, either reapproved or withdrawn. Your comments are invited either for revision of this standard or for additional standards and should be addressed to ASTM International Headquarters. Your comments will receive careful consideration at a meeting of the responsible technical committee, which you may attend. If you feel that your comments have not received a fair hearing you should make your views known to the ASTM Committee on Standards, at the address shown below.*

*This standard is copyrighted by ASTM International, 100 Barr Harbor Drive, PO Box C700, West Conshohocken, PA 19428-2959, United States. Individual reprints (single or multiple copies) of this standard may be obtained by contacting ASTM at the above address or at 610-832-9585 (phone), 610-832-9555 (fax), or service@astm.org (e-mail); or through the ASTM website (www.astm.org).*