



Designation: D 2172 – 95

Standard Test Methods for Quantitative Extraction of Bitumen From Bituminous Paving Mixtures¹

This standard is issued under the fixed designation D 2172; the number immediately following the designation indicates the year of original adoption or, in the case of revision, the year of last revision. A number in parentheses indicates the year of last reapproval. A superscript epsilon (ϵ) indicates an editorial change since the last revision or reapproval.

This standard has been approved for use by agencies of the Department of Defense.

1. Scope

1.1 These test methods cover the quantitative determination of bitumen in hot-mixed paving mixtures and pavement samples. Aggregate obtained by these test methods may be used for sieve analysis using Test Method C 117 and Test Method C 136.

1.2 The values stated in inch-pound units are to be regarded as the standard. The values given in parentheses are for information only.

1.3 *This standard does not purport to address all of the safety concerns, if any, associated with its use. It is the responsibility of the user of this standard to establish appropriate safety and health practices and determine the applicability of regulatory limitations prior to use.* Specific hazards are given in Section 7.

NOTE 1—The results obtained by these test methods may be affected by the age of the material tested, with older samples tending to yield slightly lower bitumen content. Best quantitative results are obtained when the test is made on mixtures and pavements shortly after their preparation. It is difficult to remove all the asphalt when some aggregates are used and some chlorides may remain within the mineral matter affecting the measured asphalt content.

2. Referenced Documents

2.1 ASTM Standards:

- C 117 Test Method for Materials Finer Than 75- μm (No. 200) Sieve in Mineral Aggregates by Washing²
- C 128 Test Method for Specific Gravity and Absorption of Fine Aggregate²
- C 136 Test Method for Sieve Analysis of Fine and Coarse Aggregates²
- C 670 Practice for Preparing Precision and Bias Statements for Test Methods for Construction Materials²
- D 70 Test Method for Specific Gravity of Semi-Solid Bituminous Materials³

¹ These test methods are under the jurisdiction of ASTM Committee D-4 on Road and Paving Materials and are the direct responsibilities of Subcommittee D04.25 on Analysis of Bituminous Mixtures.

Current edition approved Nov. 10, 1995. Published January 1996. Originally published as D 2172 – 63 T. Last previous edition D 2172 – 93.

² *Annual Book of ASTM Standards*, Vol 04.02.

³ *Annual Book of ASTM Standards*, Vol 04.03.

- D 604 Specification for Diatomaceous Silica Pigment⁴
 - D 979 Practice for Sampling Bituminous Paving Mixtures³
 - D 1461 Test Method for Moisture or Volatile Distillates in Bituminous Paving Mixtures³
 - D 1856 Test Method for Recovery of Asphalt from Solution by Abson Method³
 - D 2111 Test Methods for Specific Gravity of Halogenated Organic Solvents and Their Admixtures⁵
- 2.2 *Federal Specifications:*
- O-T-620a (Int. Amd. 3) 1,1,1-Trichloroethane, Technical, Inhibited Methyl Chloroform⁶
 - O-T-634 (latest) Trichloroethylene, Technical⁶

3. Summary of Test Methods

3.1 The paving mixture is extracted with trichloroethylene, 1,1,1-trichloroethane or methylene chloride using the extraction equipment applicable to the particular method. The bitumen content is calculated by difference from the mass of the extracted aggregate, moisture content, and mineral matter in the extract. The bitumen content is expressed as mass percent of moisture-free mixtures.

4. Significance and Use

4.1 All of these test methods can be used for quantitative determinations of bitumen in hot-mixed paving mixtures and pavement samples for specification acceptance, service evaluation, control, and research. Each method prescribes the solvent or solvents and any other reagents that can be used in the test method. Test Method D 1856 requires that Method A be used when asphalt is recovered from solution.

5. Apparatus

5.1 *Oven*, capable of maintaining the temperature at $230 \pm 9^\circ\text{F}$ ($110 \pm 5^\circ\text{C}$).

5.2 *Pan*, flat, 12 in. (305 mm) long, 8 in. (203 mm) wide, and 1 in. (25 mm) deep.

5.3 *Balance*, or balances having an accuracy of at least 0.01 % of the sample mass.

⁴ *Annual Book of ASTM Standards*, Vol 06.03.

⁵ *Annual Book of ASTM Standards*, Vol 15.05.

⁶ Available from Standardization Documents Order Desk, Bldg. 4 Section D, 700 Robbins Ave., Philadelphia, PA 19111-5094, Attn: NPODS.

5.4 *Hot Plate*, electric, 700-W continuous or low, medium, and high settings.

5.5 *Small-Mouth Graduate*, 1000 or 2000-mL capacity. Optional small-mouth graduate, 100-mL capacity.

5.6 *Ignition Dish*, 125-mL capacity.

5.7 *Desiccator*.

5.8 *Analytical Balance*.

6. Reagents

6.1 *Purity of Reagents*—Reagent grade chemicals shall be used in all tests. Unless otherwise indicated, it is intended that all reagents shall conform to the specifications of the Committee on Analytical Reagents of the American Chemical Society,⁷ where such specifications are available. Other grades may be used, provided it is first ascertained that the reagent is of sufficiently high purity to permit its use without lessening the accuracy of the determination.

6.2 *Ammonium Carbonate Solution*—Saturated solution of reagent grade ammonium carbonate [(NH₄)₂CO₃].

6.3 *Methylene Chloride*, technical grade. **Caution**—see Section 7.

6.4 *1,1,1-Trichloroethane*, conforming to Federal Specification O-T-620a (Int. Amd. 3). **Caution**—see Section 7.

6.5 *Trichloroethylene*, technical grade, Type 1, Federal Specification O-T-634, latest revision. **Caution**—see Section 7.

7. Hazards

7.1 The solvents listed in Section 6 should be used only under a hood or with an effective surface exhaust system in a well-ventilated area, since they are all toxic to some degree as indicated in Table 1:

TABLE 1 Solvent Toxicity

| Solvent | Time-Weighted Average Concentration for 8-h exposure for 5-day week, ppm |
|---------------------|--|
| Methylene chloride | 200 ^A |
| Trichloroethylene | 100 ^A |
| 1,1-Trichloroethane | 350 ^A |

^AThreshold Limit Concentration Committee of the American Conference of Governmental Hygienists, 1977 Values.

8. Sampling

8.1 Obtain samples in accordance with Practice D 979.

8.2 *Preparation of Test Specimens*:

8.2.1 If the mixture is not sufficiently soft to separate with a spatula or trowel, place it in a large, flat pan and warm to 230 ± 9°F (110 ± 5°C) only until it can be handled or mixed. Split or quarter the material until the mass of material required for test is obtained.

⁷ *Reagent Chemicals, American Chemical Society Specifications*, American Chemical Society, Washington, DC. For suggestions on the testing of reagents not listed by the American Chemical Society, see *Analar Standards for Laboratory Chemicals*, BDH Ltd., Poole, Dorset, U.K., and the *United States Pharmacopeia and National Formulary*, U.S. Pharmaceutical Convention, Inc. (USPC), Rockville, MD.

8.2.2 The size of the test sample shall be governed by the nominal maximum aggregate size of the mixture and shall conform to the mass requirement shown in Table 2 (Note 2):

NOTE 2—When the mass of the test specimen exceeds the capacity of the equipment used (for a particular method), the test specimen may be divided into suitable increments, tested, and the results appropriately combined for calculation of bitumen content (Section 12).

8.2.3 In addition, a test specimen is required for the determination of moisture (Section 9) in the mixtures. Take this test specimen from the remaining sample of the mixture immediately after obtaining the extraction test specimen.

NOTE 3—If recovery of bitumen from the solution obtained from the extraction test is not required, the entire test specimen may be dried to constant mass in an oven at a temperature of 230 ± 9°F (110 ± 5°C) prior to extraction instead of determining the moisture content (Section 9).

9. Moisture Content

9.1 Determine the moisture content of the mixture (see 8.2.2) in accordance using the procedure described in Test Method D 1461.

9.2 Calculate the mass of water, W_2 , (12.1) in the extraction test portion by multiplying mass percent water (9.1) by the mass of the extraction test portion, W_1 , (12.1).

TEST METHOD A

10. Apparatus

10.1 In addition to the apparatus listed in Section 5, the following apparatus is required for Test Method A:

10.1.1 *Extraction Apparatus*, consisting of a bowl approximating that shown in Fig. 1 and an apparatus in which the bowl may be revolved at controlled variable speeds up to 3600 r/min. The speed may be controlled manually or with a preset speed control. The apparatus should be provided with a container for catching the solvent thrown from the bowl and a drain for removing the solvent. The apparatus preferably shall be provided with explosion-proof features and installed in a hood or an effective surface exhaust system to provide ventilation.

NOTE 4—Similar apparatus of larger size may be used.

10.1.2 *Filter Rings*, felt or paper, to fit the rim of the bowl.

10.1.3 Low-ash paper filter rings may be used in place of the felt filter ring (10.1.2). Such filter rings shall consist of low ash filter paper stock 0.05 ± 0.005 in. thick. The nominal base weight of the paper shall be 330 ± 30 lb for a ream (500 sheets—25 by 38 in.). The ash content of the paper should not exceed 0.2 % (approximately 0.034 g per ring).

TABLE 2 Size of Sample

| Nominal Maximum Aggregate Size Standard, mm | Sieve Size | Minimum Mass of Sample, kg |
|---|------------|----------------------------|
| 4.75 | (No. 4) | 0.5 |
| 9.5 | ¾ in. | 1 |
| 12.5 | ½ in. | 1.5 |
| 19.0 | ¾ in. | 2 |
| 25.0 | 1 in. | 3 |
| 37.5 | 1½ in. | 4 |

11. Procedure

11.1 Determine the moisture content of the material in accordance with Section 9.

11.2 Place a 650 to 2500-g test portion into a bowl. See Annex A1 for alternative procedures to those prescribed herein and in 11.5.

11.3 Cover the test portion in the bowl with trichloroethylene, 1,1,1-trichloroethane or methylene chloride and allow sufficient time for the solvent to disintegrate the test portion (not over 1 h). Place the bowl containing the test portion and the solvent in the extraction apparatus. Dry and determine the mass of the filter ring and fit it around the edge of the bowl. Clamp the cover on the bowl tightly and place a beaker under the drain to collect the extract.

11.4 Start the centrifuge revolving slowly and gradually increase the speed to a maximum of 3600 r/min or until solvent ceases to flow from the drain. Allow the machine to stop, add 200 mL of trichloroethylene, 1,1,1-trichloroethane or methylene chloride and repeat the procedure. Use sufficient 200-mL solvent additions (not less than three) so that the extract is not darker than a light straw color. Collect the extract and the washings in a suitable graduate.

and dry on a steam bath and then, dry to constant mass in an oven or on a hot plate at $230 \pm 9^\circ\text{F}$ ($110 \pm 5^\circ\text{C}$). If trichloroethylene or trichloroethane is used as the extraction solvent, the preliminary drying on a steam bath may be omitted. The mass of the extracted aggregate, W_3 , is equal to the mass of the aggregate in the pan plus the increase in mass of the filter rings.

11.5.1 Use the following alternative procedure when low-ash filter rings are used: Place the aggregate and filter rings in a clean metal pan. Dry as specified above. Carefully fold the dried filter ring and stand it on the aggregate. Burn the filter ring by igniting with a bunsen burner or match. Determine the mass of the extracted aggregate in the pan, W_3 .

NOTE 5—Since dry aggregate absorbs moisture when exposed to air containing moisture, determine the mass of the extracted aggregate immediately after cooling to a suitable temperature.

11.6 Determine the amount of mineral matter in the extract by any of the following test methods:

11.6.1 *Ashing Method:*

11.6.1.1 Record the volume of the total extract in the graduate (11.4). Determine the mass of an ignition dish. Agitate

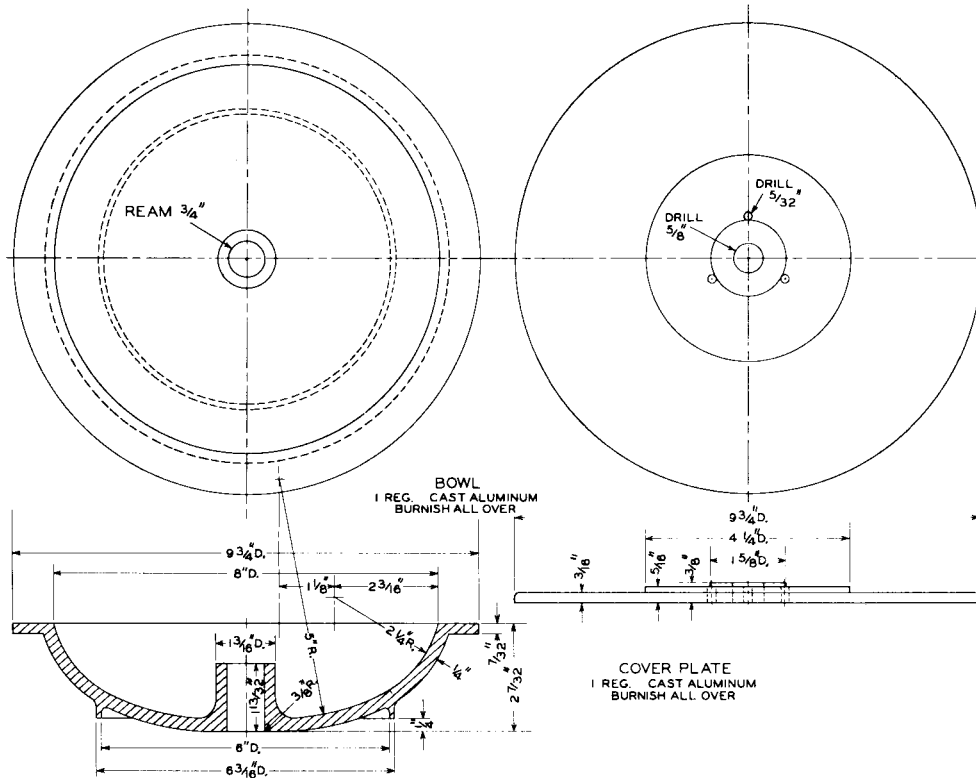

NOTE 1—See Table 3 for metric equivalents.

FIG. 1 Extraction Unit Bowl (Test Method A)

11.5 Remove the filter ring from the bowl and dry in air. If felt filter rings are used, brush off mineral matter adhering to the surface of the ring and add to the extracted aggregate. Dry the ring to constant mass in an oven at $230 \pm 9^\circ\text{F}$ ($110 \pm 5^\circ\text{C}$). Carefully remove all the contents of the bowl into a metal pan

the extract thoroughly and immediately measure approximately 100 mL into the ignition dish. Evaporate to dryness on a steam bath or hot plate, except use a steam bath when the solvent is benzene. Ash residue at a dull red heat (500 to 600°C), cool, and add 5 mL of saturated ammonium carbonate solution per

TABLE 3 Metric Equivalents for Figures

| Inch-Pound Units, in. | Metric Equivalent, cm | Inch-Pound Units, in. | Metric Equivalent, cm | Inch-Pound Units, in. | Metric Equivalent, cm |
|-----------------------|-----------------------|-----------------------|-----------------------|-----------------------|-----------------------|
| 1/8 | 0.32 | 1 1/16 | 4.3 | 5 7/8 | 14.9 |
| 3/16 | 0.48 | 1 3/4 | 4.4 | 6 | 15.2 |
| 7/32 | 0.56 | 2 3/16 | 5.5 | 6 1/8 | 15.5 |
| 1/4 | 0.63 | 2 7/32 | 5.6 | 6 3/16 | 15.7 |
| 5/16 | 0.79 | 2 5/16 | 5.9 | 6 1/4 | 15.9 |
| 3/8 | 0.95 | 2 1/2 | 6.4 | 6 1/2 | 16.5 |
| 1/2 | 1.27 | 2 5/8 | 6.9 | 7 3/8 | 18.7 |
| 5/8 | 1.59 | 2 13/16 | 7.2 | 8 | 20.7 |
| 3/4 | 1.9 | 3 | 7.6 | 9 3/4 | 24.7 |
| 1 | 2.5 | 3 3/4 | 9.6 | 10 | 25.4 |
| 1 1/8 | 2.86 | 4 | 10.2 | 10 1/8 | 25.7 |
| 1 3/16 | 3.02 | 4 1/4 | 10.8 | 12 | 30.5 |
| 1 13/32 | 3.57 | 5 | 12.7 | 14 | 35.5 |
| 1 1/2 | 3.8 | 5 7/16 | 13.8 | 14 1/2 | 37 |
| 1 5/8 | 4.1 | | | | |

gram of ash. Digest at room temperature for 1 h. Dry in an oven at 100°C to constant mass, cool in a desiccator, and determine the mass.

11.6.1.2 Calculate the mass of mineral matter in the total volume of extract, W_4 , as follows:

$$W_4 = G[V_1/(V_1 - V_2)] \quad (1)$$

where:

G = ash in aliquot, g,

V_1 = total volume, mL, and

V_2 = volume after removing aliquot, mL.

11.6.2 Centrifuge Method:

11.6.2.1 For this test method use any suitable high-speed (3000 g or higher) centrifuge of the continuous-flow type.⁸

11.6.2.2 Determine the mass of a clean empty centrifuge cup (or bowl) to 0.01 ± 0.005 g and place in the centrifuge. Position a container at the appropriate spout to catch the effluent from the centrifuging operation. Transfer all of the extract (from Test Methods A, B, C, D, or E as appropriate) to an appropriate (feed) container suitably equipped with a feed control (valve or clamp, etc.). To ensure quantitative transfer of the extract to the feed container, the receptacle containing the extract should be washed several times with small amounts of clean solvent and the washings added to the feed container. Start the centrifuge and allow to reach a constant operational speed (for example, 9000 r/min for the SMM type and 20 000 + r/min for the Sharples type). Open the feed line and feed the extract into the centrifuge at a rate of 100 to 150 mL/min. After all the extract has passed through the centrifuge, wash the feed mechanism (with centrifuge still running) with several increments of clean solvent, allowing each increment to run through the centrifuge until the effluent is essentially colorless.

11.6.2.3 Allow the centrifuge to stop and remove the cup (or bowl). Clean the outside with fresh solvent. Allow the residual solvent to evaporate in a funnel or steam hood and then dry the container in an oven controlled at $230 \pm 9^\circ\text{F}$ ($110 \pm 5^\circ\text{C}$). Cool the container and redetermine the mass immediately. The increase in mass is the mass of mineral matter, W_4 , (12.1) in the extract.

11.6.3 Volumetric Method:

11.6.3.1 Place the extract in a previously tared and calibrated flask. Place the flask in a controlled-temperature bath controlled to 0.2°F ($\pm 0.1^\circ\text{C}$), and allow to come to the temperature at which the flask was calibrated. When the desired temperature has been reached, fill the flask with solvent which has been kept at the same temperature. Bring the level of the liquid in the flask up to the neck, insert the stopper, making sure the liquid overflows the capillary, and remove from the bath. Wipe the flask dry, determine the mass to the nearest 0.1 g, and record this mass as the mass of flask plus extract. See Annex A2 for a volumetric test method alternative procedure if a controlled-temperature bath is not used as prescribed herein.

11.6.3.2 Calculate the volume of asphalt and fines in the extract as follows:

$$V_1 = V_2 - \frac{(M_1 - M_2)}{(G_1)} \quad (2)$$

where:

V_1 = volume of asphalt and fines in the extract,

V_2 = volume of the flask,

M_1 = mass of the contents of the flask,

M_2 = mass of the asphalt and fines in the extract = mass of the total samples minus the mass of the extracted aggregate, and

G_1 = specific gravity of the solvent determined to the nearest 0.001 in accordance with Test Methods D 2111.

11.6.3.3 Calculate the mass of fines in the extract as follows:

$$M_3 = K(M_2 - G_3V_1) \quad (3)$$

where:

M_3 = mass of fines in the extract,

G_2 = specific gravity of fines as determined in accordance with Test Method C 128,

G_3 = specific gravity of asphalts as determined in accordance with Test Method D 70,

$K = G_2/G_2 - G_3$,

V_1 = as given in 11.6.3.2, and

M_2 = as given in 11.6.3.2.

12. Calculation of Bitumen Content

12.1 Calculate the percent bitumen in the test portion as follows:

⁸ The Sharples Supercentrifuge and the SMM continuous-flow centrifuge have been found suitable for this test method.

$$\text{Bitumen content, \%} = \left[\frac{(W_1 - W_2) - (W_3 + W_4)}{W_1 - W_2} \right] \times 100 \quad (4)$$

where:

- W_1 = mass of test portion,
- W_2 = mass of water in the test portion,
- W_3 = mass of the extracted mineral aggregate, and
- W_4 = mass of the mineral matter in the extract.

NOTE 6—When ashless filter rings are not used, add the increase in mass of the felt filter ring to W_4 .

NOTE 7—For paving mixtures in which tar is used as the binder, a modification of Test Method A is given in Annex A3.

TEST METHOD B

13. Apparatus

13.1 In addition to the apparatus listed in Section 5, the following apparatus is required for Test Method B:

13.1.1 *Extraction Apparatus*, similar to that shown in Fig. 2.

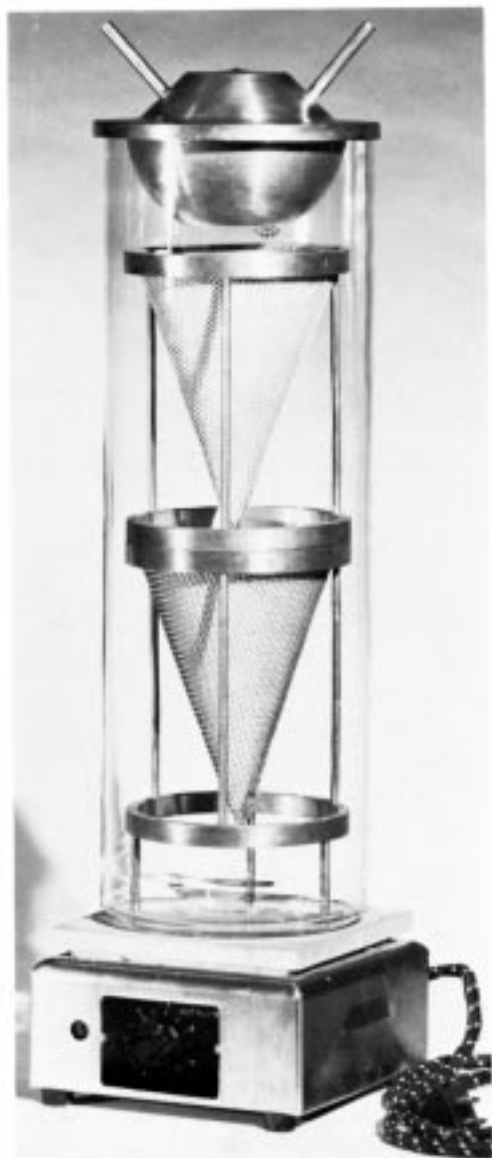

FIG. 2 Extraction Apparatus (Test Method B)

13.1.1.1 *Glass Jar*, cylindrical, plain, made of heat-resistant glass. The jar shall be free of cracks, scratches, or other evidence of flaws that might cause breakage during heating.

13.1.1.2 *Cylindrical Metal Frames*, one or two. The lower frame shall have legs of sufficient length to support the frame, including the apex of the metal cone and paper cone liner above the solvent level. When two frames are used, the upper frame shall have legs of sufficient length to support the metal cone and paper cone liner at or above the top rim of the lower frame. The legs of the upper frame shall fit securely in the top rim of the lower frame. A bail handle may be provided on the inside of the top rim of each frame for convenient handling. The metal used in fabricating the frames shall be essentially inactive to the solvents used in the test method.

13.1.1.3 *Condenser*, fabricated with a truncated hemispherical condensing surface and a truncated conical top. Other suitable geometric shapes may also be used provided they accomplish the condensing and flow functions intended. The material used in fabricating the condenser shall be essentially unreactive to water and to the solvent used and shall be provided with suitable water inlet and outlet.

13.1.1.4 *Filter Paper*, medium-grade, fast-filtering. The diameter of the paper shall be such that when folded in accordance with the directions given below, it shall completely line the metal cones in the frames.

13.1.1.5 *Asbestos-Coated Wire Mesh*, approximately 3 mm thick for use as insulation between the glass jar and hot plate.

13.1.1.6 *Electric Hot Plate, Thermostatically Controlled*, of sufficient dimensions and heat capacity to permit refluxing of the solvent as described in 15.2.5.

14. Preparation of Test Portion

14.1 Prepare a test portion for moisture determination and extraction in accordance with the procedure described in Section 8.

15. Procedure

15.1 *Moisture*—Determine the moisture content of the mixture (see 8.2) in accordance with the test method described in Section 9.

15.2 *Extraction*:

15.2.1 Dry and determine the mass of one sheet of filter paper for each frame to be used. Fold each paper on its diameter, fold the ends over, and spread it open to form a proper size to fit inside the metal cones.

15.2.2 Determine the mass of each frame with its filter paper liner to the nearest 0.5 g. Record the mass, identifying each frame by number.

15.2.3 Place the test portion in the frame or frames. If two frames are used, distribute the test portion approximately equally between the two. The top of the test portion must be below the upper edge of the paper liner. Determine the mass of each loaded frame separately to the nearest 0.5 g. Again, record the mass.

15.2.4 Use one of the solvents specified in 6.3, 6.4, or 6.5. Pour the solvent into the glass cylinder and place the bottom frame into it. The solvent level should be below the apex of the one in the (lower) frame. If two frames are used, place the upper frame in the lower frame, fitting its legs into the holes in

the upper rim of the lower frame.

NOTE 8—Sufficient denatured ethyl alcohol may be poured over the test portion(s) to wet the filter paper.

15.2.5 Place the thermal insulating pad on the hot plate and then the cylinder on the pad. Cover the condenser. Circulate a gentle steady stream of cool water through the condenser. Adjust the temperature of the hot plate so that the solvent will boil gently and a steady stream of condensed solvent flows into the cone. If necessary, adjust the temperature of the hot plate to maintain the solvent stream at a rate necessary to keep the test portions in the cone(s) completely covered with condensed solvent. Take care not to allow condensed solvent to overflow the filter cone(s). Continue the refluxing until the solvent flowing from the lower cone is light straw color (when viewed against a white background). At this point, turn off the hot plate and allow the apparatus to cool with the water running in the condenser. When boiling has ceased and the cylinder is cool enough to handle, turn off the condenser and remove from the cylinder.

15.2.6 Remove the frame assembly from the cylinder. Allow to dry in air (hood) and dry to constant mass in an oven at $230 \pm 9^\circ\text{F}$ ($110 \pm 5^\circ\text{C}$) (see Note 5).

15.2.7 Transfer the extract quantitatively to the graduated cylinder (5.5) and determine mineral matter in the extract in accordance with 11.6.1. Alternatively, mineral matter in the extract may be determined by the method described in 11.6.2 or 11.6.3. In this case, it is not necessary to transfer the extract from the extraction cylinder to a graduated cylinder. The extract may be transferred directly from the extraction cylinder to the centrifuge feed container (11.6.2.2).

16. Calculation of Bitumen Content

16.1 Calculate the percent bitumen in the test portion in accordance with the procedure described in Section 12.

TEST METHOD C

17. Apparatus

17.1 In addition to the apparatus listed in Section 5, the following is required for Test Method C:

17.1.1 *Extraction Apparatus*, consisting of a container, condenser lid, and stand. Suitable types are shown in Fig. 3 and Fig. 4; however, other extractors of differing shapes may also be used successfully. A standard 26-qt (25-L) aluminum cooking utensil has been found to be suitable. The important features regardless of shape are that the extractors have snug-fitting lids, be of sufficiently large size to accommodate the required test portion, and include cooling fins arranged so as to provide for efficient refluxing.

17.1.2 *Basket*, for test portion as shown in Fig. 3 or one designed for use with an extractor of different shape.

17.1.3 *Filter Cloth*,⁹ of approximately 185 mesh, placed over the No. 4 screen and shaped to cover the inside of the basket completely to ensure retention of all aggregate sizes greater than the cloth mesh during extraction.

⁹ A 16XX Swiss Stencil Cloth, available from the Atlas Silk Screen Supply Co., 1733 Milwaukee Ave., Chicago, IL 60647, is suitable for this purpose.

18. Preparation of Test Portions

18.1 Prepare test portions for moisture determination and extraction in accordance with the procedure described in Section 8.

19. Procedure

19.1 *Moisture*—Determine the moisture content of the mixture (see 8.2) in accordance with the test method described in Section 9.

19.2 *Extraction*:

19.2.1 Determine the mass of the sample (3500 to 10 000 g) in the tared basket assembly to the nearest 1 g and place in the extractor. Pour 1150 to 1250 mL of trichloroethylene, 1,1,1-trichloroethane, or methylene chloride (Section 6) over the test portion. Fit the extractor lid tightly in place and allow water to circulate freely in the top. Apply heat from either a gas burner or an electric hot plate.

19.2.2 Reflux the sample 1.5 to 3 h until all bitumen is extracted from the aggregate. Shut down the extractor after 1.5 h and inspect the test portion. Mix the test portion with a trowel and continue extraction to completion.

NOTE 9—The test portion is completely extracted when, upon inspection, no discoloration is found on the aggregate or on the surface of a trowel that has thoroughly mixed the test portion.

19.2.3 Remove the basket with the test portion, dry in air and then to constant mass on a hot plate or in an oven at $230 \pm 9^\circ\text{F}$ ($110 \pm 5^\circ\text{C}$).

19.2.4 Drain the extract from the extractor and wash clean with fresh solvent. Combine the extract and the washings in a graduated cylinder.

19.2.5 Determine the mass of mineral matter in the extract in accordance with the test method described in 11.6.1, 11.6.2, or 11.6.3.

20. Calculation of Bitumen Content

20.1 Calculate the percent bitumen in the test portion in accordance with the procedure described in Section 12.

TEST METHOD D

21. Apparatus

21.1 In addition to the apparatus listed in Section 5, the following apparatus is required for Test Method D:

21.1.1 *Extraction apparatus*, Fig. 5 consisting of an extraction kettle of metal or borosilicate glass, fitted with a perforated basket and a condenser top. The underside of the condenser shall be covered with numerous rounded knobs to distribute the condensed solvent uniformly over the surface of the sample. The suspension of the basket shall be arranged to support the basket $\frac{1}{2}$ in. (12.7 mm) above the bottom of the kettle, for immersion of test portion in the solvent, and at least 3 in. (76.5 mm) above the bottom of the kettle for refluxing (see Note 4).

21.1.2 *Cloth Filter Sacks*, with an elastic hem for lining the basket.

22. Preparation of Test Portions

22.1 Prepare test portions for moisture determination and extraction in accordance with the procedure described in Section 8.

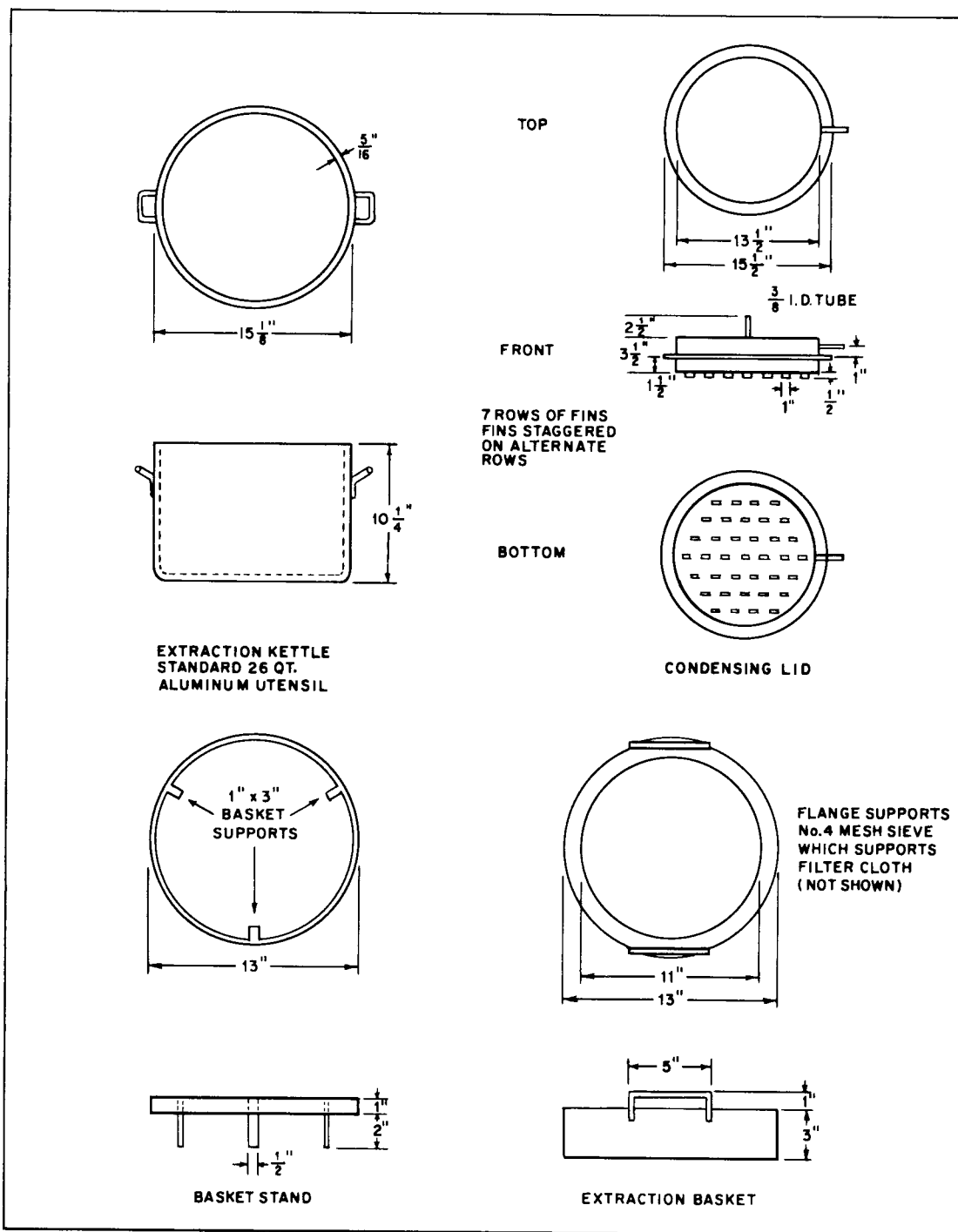

FIG. 3 Extraction Apparatus (Test Method C)

23. Procedure

23.1 *Moisture*—Determine the moisture content of the mixtures (see 8.2) in accordance with the test method described in Section 9.

23.2 *Extraction:*

23.2.1 Insert a filter sack in the extraction basket and determine the mass with the tare pan to determine the total tare weight. Place the test portion (Note 2) in the filter sack and determine the total mass. Calculate the mass of the test portion.

23.2.2 Attach the suspension rod to the loaded basket and

set the assembly into the extraction kettle. Pour approximately 600 mL of solvent (6.2, 6.3, or 6.4) over the test portion. Set the condenser cover in place on the kettle. Provide a flow of cold water through the condenser lid. Raise the basket to immersion level, for example 1/2 in. (13 mm) above the bottom of kettle, by inserting the support pin through the upper hole of the suspension rod. Place the extractor on the hot plate and adjust the heating rate so that solvent is maintained at a gentle boil, avoiding vigorous boiling which might wash fines over sides of basket.

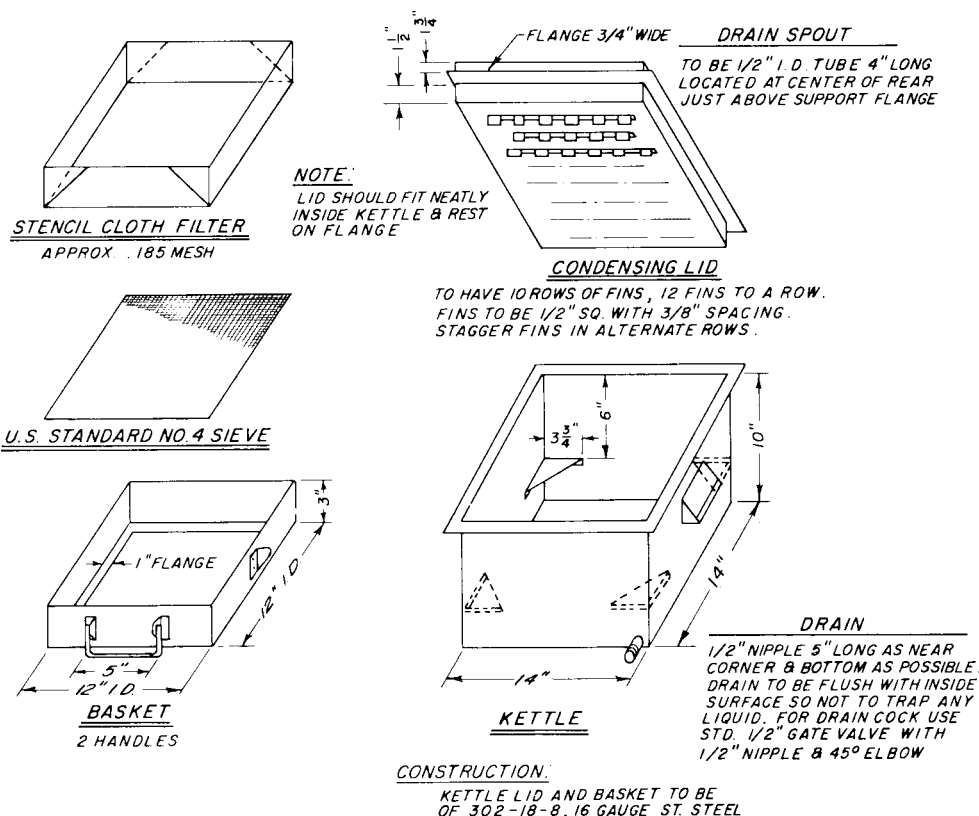

STAND MADE FROM 1" X 1" X 1/8" ANGLE IRON

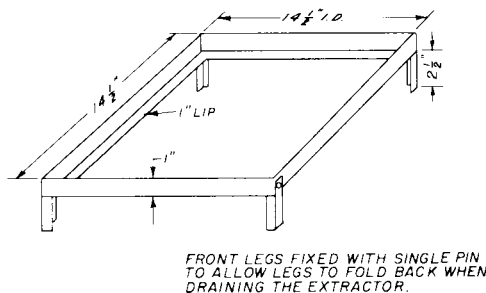

NOTE 1—See Table 3 for metric equivalents.

FIG. 4 Extractor Unit (Test Method C)

23.2.3 Continue heating with the test portion in immersion position for 15 to 30 min and then raise the basket to refluxing level. Increase the heat and maintain active boiling until solvent dripping from the basket appears light straw color when viewed against a white background. If a stainless steel kettle is used, lift out the basket and the condenser cover assembly for examination of the solvent.

23.2.4 Remove the extractor from the hot plate and allow to cool for several minutes. Lift out the basket and condenser assembly. Cover the kettle, remove the filter sack, distribute its contents onto the tared pan in which the mass of the test portion was originally determined. Place the filter sack on top of the recovered aggregate. Dry on a steam bath and then in an oven at $230 \pm 9^\circ\text{F}$ ($110 \pm 5^\circ\text{C}$) to constant mass. Transfer the

extraction to a 1000-mL graduate. Wash the extractor clean with solvent and add the washings to the extract.

23.2.5 Determine the mineral matter in the extract in accordance with any of the procedures in 11.6.

24. Calculation of Bitumen Content

24.1 Calculate the percent bitumen in the test portion in accordance with the procedure described in Section 12.

TEST METHOD E

25. Apparatus

25.1 In addition to the apparatus listed in Section 5, the following apparatus is required for Test Method E:

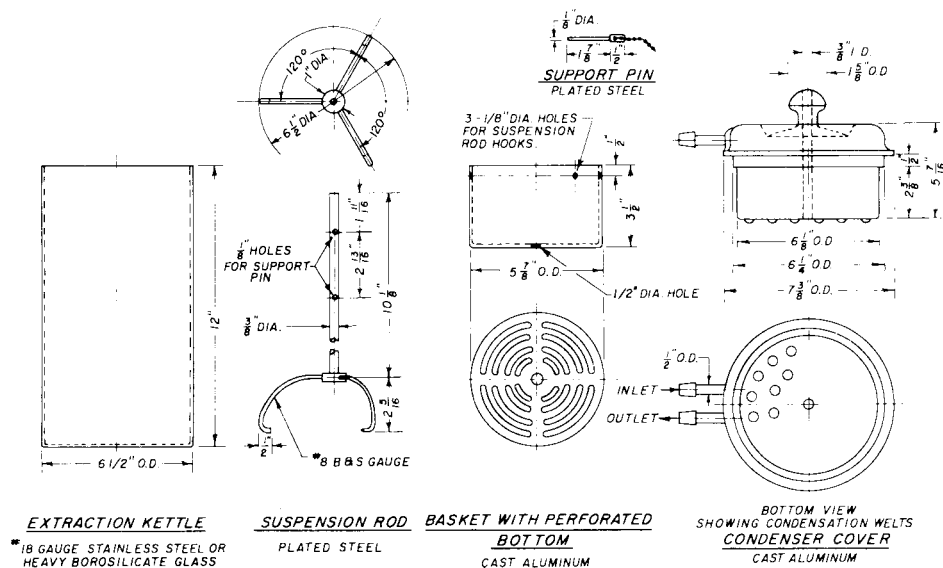

FIG. 5 Extractor Unit (Test Method D)

NOTE 1—See Table 1 for metric equivalents.
NOTE 2—See Table 3 for metric equivalents.

25.1.1 *Vacuum Extractor*, complete with the vacuum pump, gasket, rubber tubing, filter paper, support plate, and funnel ring, similar to that shown in Fig. 6.

25.1.2 *Filter Paper*, medium-grade, fast-filtering, 330 mm in diameter.

25.1.3 *Stainless Steel Beaker*, having a capacity of 9 qt (8.5 L).

25.1.4 *Erlenmeyer Flasks*, glass, two, having a capacity of 4000 mL each.

25.1.5 *Graduate*, glass, having a capacity of 500 mL.

25.1.6 *Wash Bottle*, plastic, having a capacity of 500 mL.

25.1.7 *Dial Thermometer*, having a range from 50 to 180°F (10 to 82°C).

25.1.8 *Mixing Spoon*, 12 in. (305 mm) long.

25.1.9 *Spatula*, 9 in. (229 mm) long.

25.1.10 *Stiff Bristled Brush*, 1 in. (25 mm) wide.

25.1.11 *Erlenmeyer Flask*, glass, having a capacity of 1000 mL.

25.1.12 *Watch Glass*, having a 4-in. (102-mm) diameter.

25.1.13 *Metal Tongs*, 6 to 8 in. (152 to 203 mm) long.

NOTE 10—Use apparatus and materials listed under 25.1.11, 25.1.12, 25.1.13, and 26.1.2 only with paving mixtures hard to filter, as in Method E-II.

26. Reagents and Materials

26.1 *Diatomaceous Silica Filtering Aid* conforming to Type B of Specification D 604.¹⁰

26.2 *Ethyl Alcohol*, denatured.

26.3 *Methylene Chloride*.

27. Preparation of Test Portions

27.1 Prepare test portions for moisture determination and extraction in accordance with the procedure described in Section 8.

28. Procedure

28.1 *Moisture*—Determine the moisture content of the mixture (see 8.2) in accordance with the test method described in Section 9.

28.2 *Extraction:*

28.2.1 Place the extraction test portion into the tared stainless steel beaker and determine the mass.

28.2.2 If the test portion is above 130°F (54°C), allow it to cool to a temperature less than 130°F (54°C). When sufficiently cool, pour 200 mL of denatured alcohol over the specimen. Add approximately 700 mL of methylene chloride and stir until the asphalt is visually in solution.

NOTE 11—If equipment is available, an ultrasonic cleaning tank may be used instead of the beaker (28.2.1) and the bitumen brought into solution (28.2.2) in the cleaning apparatus.

TEST METHOD E-I

28.2.3 Place a dry tared filter paper on the vacuum extractor, taking care to center the filter, and tighten the wing nuts finger tight.

28.2.4 Start the vacuum pump and decant the solvent from the beaker into the extractor, taking care not to transfer the aggregate from the beaker to the extractor. Stop the vacuum when all solvent has been removed.

28.2.5 Add another 700 mL of methylene chloride to the sample container and stir.

28.2.6 Repeat 28.2.4 and 28.2.5 until the solution is a light straw color and the aggregate is visually clean. After the last wash, gently pour the entire sample into the extractor and thoroughly rinse all aggregate particles from the sample container. Carefully spread the aggregate evenly over the filter.

28.2.7 Operate the vacuum pump for a few minutes after the last wash to aid in drying the test portion. Scrape the aggregate away from the side of the funnel ring toward the center of the filter to avoid loss when the ring is removed. Remove the ring and brush the clinging aggregate into the drying pan. Then pick

¹⁰ Celite 110, manufactured by Johns-Manville, has been found satisfactory for this purpose.

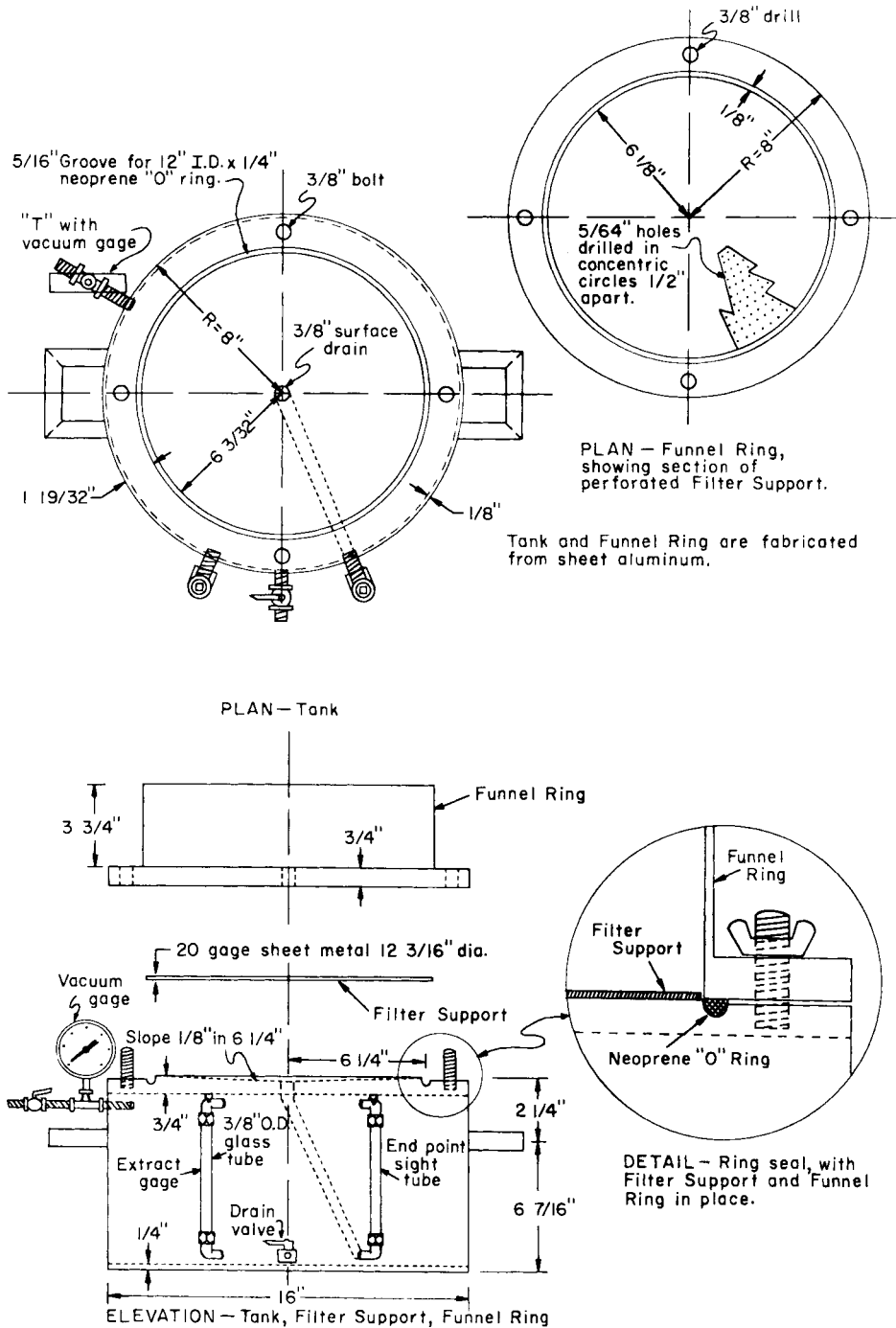

NOTE 1—The detail, dimensions, and materials shown have been found satisfactory. Modifications are permissible, provided it can be demonstrated that performance of the equipment is not adversely affected.

FIG. 6 Vacuum Extractor (Test Method E)

up the filter paper and aggregate by holding the paper on opposite sides and raising it straight up. Place the test portion in the tared pan and brush the clinging aggregate from the filter into the pan.

28.2.8 Dry the extracted aggregate and filter to a constant mass in an oven at $230 \pm 9^\circ\text{F}$ ($110 \pm 5^\circ\text{C}$).

28.2.9 Determine the mass of the filter and aggregate in the pan and record. Subtract the mass of the filter and pan to determine the mass of the extracted aggregate.

28.2.10 Transfer the extract to the graduated cylinder (5.5) and determine the mineral matter in the extract in accordance with the test method described in 11.6.1. Alternatively, mineral matter in the extract may be determined in accordance with the test method described in 11.6.2 or 11.6.3. In this case, it is not necessary to transfer the extract to the graduated cylinder. The extract may be transferred directly from the extractor to the centrifuge feed container (11.6.2.2).

NOTE 12—Sections 28.2.10 and 28.2.16 may be omitted when this test method is used only for control of paving mixture bitumen content during construction (plant control).

TEST METHOD E-II

28.2.11 To extract a slow-filtering paving mixture efficiently, prepare the test portion as in 28.2.1 and 28.2.2.

28.2.12 Place a dry tared filter paper on the vacuum extractor, taking care to center the filter, and tighten the wing nuts finger tight.

28.2.13 Weigh 50 g of oven-dried diatomaceous silica filtering aid into a 100-mL Erlenmeyer flask and add 500 mL of methylene chloride. Swirl until the diatomaceous silica is completely in suspension.

28.2.14 Immediately pour the diatomaceous silica and methylene chloride over the filter. Start the vacuum pump and let it run until the pad formed by the diatomaceous silica is surface dry and begins to crack slightly.

28.2.15 Place the watch glass in the extractor and gently pour the solvent from the test portion over it. Remove it with tongs and wash with the wash bottle. Add the rest of the sample and proceed as in 28.2.4-28.2.9. Subtract the mass of the drying pan, filter paper, and diatomaceous silica from the total mass to determine the (dry) mass of aggregate.

28.2.16 Determine the amount of mineral matter in the extract in accordance with the procedure described in 28.2.10 (see Note 12).

29. Calculation of Bitumen Content (Applicable to Both Method E-I and Method E-II)

29.1 Calculate the percent bitumen in the test portion in accordance with the procedure described in Section 12.

30. Precision and Bias

30.1 *Mixtures with Aggregate Water Absorption Capacities of Less than 1.25 %* (Note 13):

| Test and Type Index | Standard Deviation, (1s) ^A | Acceptable Range of Two Test Results (d2s) ^A |
|-------------------------------------|---------------------------------------|---|
| Single-operator precision (Note 15) | | |
| Method A (centrifuge) | 0.21 | 0.59 |
| Method B, C, and D (reflux) | 0.19 | 0.54 |
| Method E (vacuum) | 0.21 | 0.59 |

| Test and Type Index | Standard Deviation, (1s) ^A | Acceptable Range of Two Test Results (d2s) ^A |
|-------------------------------------|---------------------------------------|---|
| Multilaboratory precision (Note 15) | | |
| Method A (centrifuge) | 0.22 | 0.62 |
| Method B, C, and D (reflux) | 0.23 | 0.65 |
| Method E (vacuum) | 0.22 | 0.59 |

^A These numbers represent, respectively, the (1s) and (d2s) limits as described in Practice C 670.

NOTE 13—These precision statements are based on an analysis of the AMRL¹¹ data base from 1974 through 1985. Asphalt cements used over the years included AC-10, AC-15, AC-20, AR-2000, AR-4000, and AR-8000. Gradations consistently had a nominal maximum aggregate size of at most ¾-in. stone. Water absorption capacities were consistently below 1.25 %.

NOTE 14—A statistical evaluation showed no difference in precision between various solvents. Therefore the precision statement for each test method includes data obtained using any of the following solvents: benzene, trichloroethane, trichloroethylene, methylene chloride.

30.2 *Mixtures with Aggregate Water Absorption Capacities Greater than 1.25 and Less than 2.5 %:*

30.2.1 The precision and bias statements for aggregates with these properties are currently being developed.

30.3 *Mixtures with Aggregate Water Absorption Capacities Greater than 2.5 %* (Note 15):

| Test and Type Index | Standard Deviation, (1s) ^A | Acceptable Range of Two Test Results (d2s) ^A |
|-----------------------------|---------------------------------------|---|
| Single-operator precision | | |
| Method A (centrifuge) | 0.30 | 0.85 |
| Method B, C, and D (reflux) | 0.19 | 0.54 |
| Method E (vacuum) | 0.27 | 0.76 |
| Multilaboratory precision | | |
| Method A (centrifuge) | 0.37 | 1.05 |
| Method B, C, and D (reflux) | 0.37 | 1.05 |
| Method E (vacuum) | 0.29 | 0.82 |

^A These numbers represent, respectively, the (1s) and (d2s) limits as described in Practice C 670.

NOTE 15—These precision statements are based on 1 material, 2 replicates, and 112, 42, and 30 laboratories for the centrifuge, reflux, and vacuum extraction methods, respectively. The data were obtained from the AASHTO Materials Reference Laboratory (AMRL)¹¹ results for sample pair 37 and 38, distributed in 1992 for the Bituminous Mixture Design proficiency program.

30.4 *Bias*—Since there is no acceptable reference material suitable for determining the bias for this test method, no statement of bias can be made.

¹¹ AASHTO Materials Reference Laboratory (AMRL), National Institute of Standards and Technology (NIST), Gaithersburg, MD 20899.

ANNEXES**(Mandatory Information)****A1. Test Method A Alternative Procedure**

A1.1 In 11.2 place a 650 to 2500-g test portion in a bowl that has been previously dried to a constant mass with the filter ring.

bowl and drying in air, dry the bowl with the filter ring to a constant mass under an infrared lamp or in an oven at $230 \pm 9^\circ\text{F}$ ($110 + 5^\circ\text{C}$).

A1.2 In 11.5 instead of removing the filter ring from the

A2. Test Method A (Volumetric Method) Alternative Procedure

A2.1 Instead of using a controlled-temperature bath as prescribed in 11.6.3.1, measure the temperature of the extract

and make necessary corrections to the volume of the flask and density of asphalt and the solvent.

A3. Test Method A Modification for Determination of Tar

A3.1 Cover the test portion in the bowl with crystal-free creosote and place the bowl for 1 h on a hot plate or in an oven maintained at 240°F (116°C). Proceed in accordance with 11.3 and 11.4 except use two 200-mL additions of creosote previously heated to 240°F (116°C). Treat the test portion in the bowl with three 200-mL additions of trichloroethylene, following the same procedure.

evaporate the aliquot portion of the solvent (11.6.1) on the steam bath until trichloroethylene is removed. Then evaporate the remaining solvent to dryness on a hot plate and ash as directed in 11.6.1.

A3.3 Calculate the percent tar in the sample in accordance with Section 12.

A3.2 Continue in accordance with 11.5 and 11.6.1 except

ASTM International takes no position respecting the validity of any patent rights asserted in connection with any item mentioned in this standard. Users of this standard are expressly advised that determination of the validity of any such patent rights, and the risk of infringement of such rights, are entirely their own responsibility.

This standard is subject to revision at any time by the responsible technical committee and must be reviewed every five years and if not revised, either reapproved or withdrawn. Your comments are invited either for revision of this standard or for additional standards and should be addressed to ASTM International Headquarters. Your comments will receive careful consideration at a meeting of the responsible technical committee, which you may attend. If you feel that your comments have not received a fair hearing you should make your views known to the ASTM Committee on Standards, at the address shown below.

This standard is copyrighted by ASTM International, 100 Barr Harbor Drive, PO Box C700, West Conshohocken, PA 19428-2959, United States. Individual reprints (single or multiple copies) of this standard may be obtained by contacting ASTM at the above address or at 610-832-9585 (phone), 610-832-9555 (fax), or service@astm.org (e-mail); or through the ASTM website (www.astm.org).